



# City of Belle Isle

Universal Engineering Sciences 3532 Maggie Blvd., Orlando, FL 32811  
Tel 407-581-8161 \* Fax 407-581-0313 \* [www.universallengengineering.com](http://www.universallengengineering.com)

## PERMIT CARD - PLEASE POST AT JOB SITE

THIS DOCUMENT BECOMES YOUR PERMIT WHEN PROPERLY VALIDATED

Per FBC 105.3.3: An enforcing authority may not issue a building permit for any building construction, erection, alteration, modification or addition unless the permit either includes on its face or there is attached to the permit the following statement: "NOTICE: In addition to the requirements of this permit, there may be additional restrictions applicable to this property that may be found in the public records of this county, and there may be additional permits required from other governmental entities such as water management districts, state agencies, or federal agencies." The issuance of this permit does not grant permission to violate any applicable City, Orange County, State of Florida and/or Federal codes and/or ordinances. Separate permits are required for Signs, Roofing, Electrical, Gas, Plumbing and Mechanical services. This permit becomes VOID if the work authorized is not commenced within 6 months, or is suspended or abandoned for a period of 6 months after commencement. WORK SHALL BE CONSIDERED SUSPENDED IF AN APPROVED INSPECTION HAS NOT BEEN MADE WITHIN A 6 MONTH PERIOD. PERMISSION IS GRANTED TO DO THE FOLLOWING WORK ACCORDING TO THE CONDITIONS HEREON AND THE APPROVED PLANS AND SPECIFICATIONS, SUBJECT TO COMPLIANCE WITH THE ORDINANCES OF THE CITY OF BELLE ISLE, FLORIDA.

Scope of Work: PLUMBING: Install Solar Panels

Permit Number: 2015-12-010

Date of Application: 12/09/2014

Date Permit Issued: 12/11/2014

Comments: None

### Project Information

Address: 3633 Isle Vista Avenue, Belle Isle, FL 32812  
Parcel ID: 20-23-30-0668-00-910  
Property Owner: Brito, Sonal & Suneeta  
Phone Number: 407 545 3590  
\*\*\*\*\*  
Company Name: Everything Solar  
Contractor Name: Launs, Brad  
License Number: CVC56749  
Address: 1901 W. Colonial Drive, Orlando, FL 32804  
Phone Number: 407 545 3590

**WARNING TO OWNER:** "YOUR FAILURE TO RECORD A NOTICE OF COMMENCEMENT MAY RESULT IN YOU PAYING TWICE FOR IMPROVEMENTS TO YOUR PROPERTY. IF YOU INTEND TO OBTAIN FINANCING, CONSULT WITH YOUR LENDER OR AN ATTORNEY BEFORE RECORDING YOUR NOTICE OF COMMENCEMENT." ON THE JOB INSPECTION(S) MUST BE MADE BEFORE PROCEEDING WITH SUBSEQUENT WORK. THIS CARD MUST BE DISPLAYED OUTSIDE AND BE PROTECTED FROM THE WEATHER WHILE BEING VISIBLE FROM THE STREET UNTIL THE FINAL INSPECTIONS HAVE BEEN APPROVED.

### BUILDING FEATURES

#### IMPACT FEES

School \$  
Traffic \$

#### ZONING FEES

Zoning Fee \$

#### UNIVERSAL ENG - BUILDING FEES

Cert of Occ \$  
Demo \$  
Building \$  
Fence \$  
Driveway \$  
Shed \$  
Window(s) \$  
Door(s) \$  
PrePower \$  
Electrical \$  
Temp Pole \$  
Plumbing \$64.50  
Mechanical \$  
Gas \$  
Roofing \$  
Boat Dock \$  
Screen Encl \$  
Swimming Pool \$  
Sign \$

#### SURCHARGE FEES

Surcharge Fee \$2.00  
Surcharge Fee \$2.00

**TOTAL FEES \$68.50**

Date Paid 12-12-14

CC or Check # VISA 5344

Amount Paid 68.50

The person accepting this permit shall conform to the terms of the application on file and construction shall conform to the requirements of the Florida Building Code (FS 553).

#### BUILDING INSPECTOR USE ONLY

#### IF APPLICABLE:

Have Zoning Approval Conditions Been Met? YES NO Have Stormwater Approval Conditions Been Met? YES NO Silt fencing in place? YES NO Turbidity Barrier in place? YES NO

#### BUILDING

1<sup>st</sup> Survey specific foundation plan must be onsite before slab pour. Approved Plan on Site? \_\_\_\_\_  
(Footing/Foundation)

2<sup>nd</sup> \_\_\_\_\_  
(Slab)

3<sup>rd</sup> \_\_\_\_\_  
(Lintel) (Wall Reinforcing on Masonry Building)

4<sup>th</sup> \_\_\_\_\_  
(Exterior Framing) (Roof/Wall Sheathing)

5<sup>th</sup> \_\_\_\_\_  
(Framing) (To be made after Plumbing/ Mechanical/ Electrical Rough-Ins & Windows/Doors Installed)

6<sup>th</sup> \_\_\_\_\_  
(Insulation to be Made After Roof Installed)

7<sup>th</sup> \_\_\_\_\_  
(Drywall)

8<sup>th</sup> \_\_\_\_\_  
(Sidewalk/Driveway)

9<sup>th</sup> \_\_\_\_\_  
(Other)

10<sup>th</sup> \_\_\_\_\_  
(Final - After MEP and Other Applicable Finals)

#### ROOFING

1<sup>st</sup> ROOFING Deck Nailing/Dry-in/Flashing \_\_\_\_\_

2<sup>nd</sup> ROOFING Covering In-Progress \_\_\_\_\_

3<sup>rd</sup> ROOFING Covering Final \_\_\_\_\_

PLUMBING (Pool-Piping, Solar, Irrigation, Water Treatment Equip, Etc...)

1<sup>st</sup> \_\_\_\_\_  
(Underground) 2<sup>nd</sup> \_\_\_\_\_  
(Sewer)

3<sup>rd</sup> \_\_\_\_\_  
(Rough-In/Tub Set) 4<sup>th</sup> \_\_\_\_\_  
(Final)

#### CHECK APPROPRIATE BOX

GAS \_\_\_ Natural \_\_\_ LP  MECHANICAL  ELECTRICAL  LOW VOLTAGE

1<sup>st</sup> \_\_\_\_\_  
(Rough-In) 2<sup>nd</sup> \_\_\_\_\_  
(Final)

Inspection requests are to be emailed to [BDscheduling@UniversalEngineering.com](mailto:BDscheduling@UniversalEngineering.com); a confirmation email will be sent back to you upon scheduling. Next-Day Inspection requests must be made by 1pm. Please include the following in your request: Permit #, project address, type of inspection, date of the requested inspection, a contact name & a contact phone number. AM or PM may be requested but cannot be guaranteed.

For a copy of your permit, or to check inspection results, please visit <https://universallengengineering.sharefile.com/ff094edc4-832d-44bd-9809-ecf32f9e2e63>  
login ID = [cobi@universallengengineering.com](mailto:cobi@universallengengineering.com) password = [universa113](https://universallengengineering.sharefile.com/ff094edc4-832d-44bd-9809-ecf32f9e2e63)

PROJECT NUMBER 0115.1400549.0000

TASK NUMBER 01

CITY OF BELLE ISLE  
Permit Application Review Sheet

Permit Number	2015-12-010
Property Owner	Brito Sonal & Suneeta
Address	3633 Isle Vista Ave
Nature of Improvement	Plumbing: solar panels
Received Application	12-9-14
Sent for Stormwater Review	
Stormwater Approved	/
Sent for Zoning Review	
Zoning Approved	/
Applied for Variance	
Variance Approved	
Sent to BO for Review	12-9-14
Building Official Approved	RA
Comments	
1.	Susan 12-9-14 GL ✓ BL ✓ WC ✓ tax rec ✓ NOC ✓
2.	review wo 44768
3.	Raph 12-9-14 Plans received
4.	
5.	
6.	
7.	
8.	
9.	
10.	
11.	
12.	



### City of Belle Isle

Universal Engineering Sciences 3532 Maggie Blvd., Orlando, FL 32811  
Tel 407-581-8161 \* Fax 407-581-0313 \* [www.universalengineering.com](http://www.universalengineering.com)

RECEIVED  
12-9-14

### APPLICATION FOR PLUMBING PERMIT

WARNING TO OWNER: YOUR FAILURE TO RECORD A NOTICE OF COMMENCEMENT MAY RESULT IN YOUR PAYING TWICE FOR IMPROVEMENTS TO YOUR PROPERTY. A NOTICE OF COMMENCEMENT MUST BE RECORDED AND POSTED ON THE JOB SITE BEFORE THE FIRST INSPECTION. IF YOU INTEND TO OBTAIN FINANCING, CONSULT WITH YOUR LENDER OR AN ATTORNEY BEFORE RECORDING YOUR NOTICE OF COMMENCEMENT.

DATE OF APPLICATION: 11/20/14 PERMIT NUMBER 2015-12-010  
The undersigned hereby applies for a permit to make plumbing installations as indicated below. PLEASE PRINT

Project Address 3633 Isle Vista Ave, Belle Isle FL 32809  32812  
Property Owner Sonal & Suneeta Brito Phone 407-545-3590  
Property Owner's Mailing Address 3633 Isle Vista Ave City Belle Isle  
State FL Zip Code 32812 Parcel Id Number: 20-23-30-01608-00-910

To obtain this information, please visit <http://www.ocpafl.org/Searches/ParcelSearch.aspx>

Class of Building: Old  New  Type of Building: Residential  Commercial  Other   
Type of Work: New  Alteration  Addition  Repair  Type of System: Sewer  Septic  Re-pipe

YOU MAY BE REQUIRED TO PROVIDE SEPTIC SYSTEM VERIFICATION FOR NEW / ALTERED / ADDITION to Septic System - ORANGE COUNTY DOCUMENT 64E-6

VALUATION OF JOB (labor & materials) \$ 5580.00

FIXTURES	Quantity	FIXTURES	Quantity
Water Closets (Toilet)		Dishwashers	
Bathtubs		Laundry Tubs	
Urinals		Floor Drains	
Disposals		Grease Traps	
Washing Machines		Trailer Connections	
Water Heaters		Spa	
Sewer		Solar	1
Catch Basins/Sumps		Pool Piping	
Service Sink		*Irrigation: (# Systems / # Heads)	
Lavatory (Bathroom Sink)		Water Softener	
Showers		Re-pipe	
Sinks		Miscellaneous (Specify)	

\*Per FBC, Sec. 608, a Backflow Preventer must be installed & tested; the report must be posted with permit for Final Inspection

Building Official: [Signature] Date 12-10-14  
Verified Contractor's Licenses & Insurance are on file \_\_\_\_\_ Date \_\_\_\_\_

Permit Fee \_\_\_\_\_  
Review Fee \_\_\_\_\_  
3% State Surcharge (\$4.00 minimum) \_\_\_\_\_  
Total Permit Fee \_\_\_\_\_

I hereby certify that the above is true and correct to the best of my knowledge and make Application for Permit as outlined above, and if same is granted I agree to conform to all Florida Building Code Regulations and City Ordinances regulating same and in accordance with plans submitted. The issuance of this permit does not grant permission to violate any applicable Town and/or State of Florida codes and/or ordinances.

LICENSE HOLDER SIGNATURE Brad Launs LICENSE # CVC 56749  
LICENSE HOLDER NAME Brad Launs COMPANY NAME Everything Solar  
Street Address 1901 W. Colonial Dr.  
City Orlando State FL Zip Code 32804 Phone Number 407-545-3590  
Email Address energyfl@gmail.com

NOTE: The Building Permit Number is required if the Plumbing Installation is associated with any construction or alteration where a Building Permit has been issued.

Building Permit Number \_\_\_\_\_



# COBI Permit Fee Calculation Form



Reviewer Signature: R Jones Date: 12-9-14

Permit Type:	<u>SOLAR WATER HEATER</u>	Job Cost:	\$ _____
Permit Fee:	\$ <u><del>64.50</del> 43.00</u>		
Plans Review Fee:	\$ <u>21.50</u>	(50% of permit fee – excluding ReRoofs)	
1.5% State Fee:	\$ <u><del>9.68</del> 2.00</u>		
1.5% State Fee:	\$ <u><del>9.68</del> 2.00</u>		
TOTAL BUILDING FEE:	\$ <u><del>66.44</del> 68.50</u>	(does not include Zoning fees or Deposits)	

Note: Total gets doubled for SWO/AFT permits

43  
21.50  
-----  
64.50



Permit Number:  
Folio/Parcel Identification Number:  
Prepared by:

Return to:

### NOTICE OF COMMENCEMENT

State of Florida, County of Orange

The undersigned hereby gives notice that improvement will be made to certain real property, and in accordance with Chapter 713, Florida Statutes, the following information is provided in this Notice of Commencement.

- Description of property** (legal description of the property, and street address if available)  
Belle Vista on Lake Conway 49/12 Lot 91
- General description of improvement**  
Solar Water heating
- Owner information or Lessee information if the Lessee contracted for the improvement**  
Name Sonal Brito  
Address 3921 Isle Vista Ave Belle Isle Fl 32812  
Interest in Property \_\_\_\_\_  
Name and address of fee simple titleholder (if different from Owner listed above)  
Name \_\_\_\_\_  
Address \_\_\_\_\_
- Contractor**  
Name Everything Solar Telephone Number 407-545-3590  
Address 1901 W. Colonial Dr. Orlando, Fl 32804
- Surety** (if applicable, a copy of the payment bond is attached)  
Name \_\_\_\_\_ Telephone Number \_\_\_\_\_  
Address \_\_\_\_\_ Amount of Bond \$ \_\_\_\_\_
- Lender**  
Name \_\_\_\_\_ Telephone Number \_\_\_\_\_  
Address \_\_\_\_\_
- Persons within the State of Florida designated by Owner upon whom notices or other documents may be served as provided by §713.13(1)(a)7, Florida Statutes.**  
Name \_\_\_\_\_ Telephone Number \_\_\_\_\_  
Address \_\_\_\_\_
- In addition to himself or herself, Owner designates the following to receive a copy of the Lienor's Notice as provided in §713.13(1)(b), Florida Statutes.**  
Name \_\_\_\_\_ Telephone Number \_\_\_\_\_  
Address \_\_\_\_\_
- Expiration date of notice of commencement** (the expiration date may not be before the completion of construction and final payment to the contractor, but will be 1 year from the date of recording unless a different date is specified) \_\_\_\_\_

WARNING TO OWNER: ANY PAYMENTS MADE BY THE OWNER AFTER THE EXPIRATION OF THE NOTICE OF COMMENCEMENT ARE CONSIDERED IMPROPER PAYMENTS UNDER CHAPTER 713, PART I, SECTION 713.13, FLORIDA STATUTES, AND CAN RESULT IN YOUR PAYING TWICE FOR IMPROVEMENTS TO YOUR PROPERTY. A NOTICE OF COMMENCEMENT MUST BE RECORDED AND POSTED ON THE JOB SITE BEFORE THE FIRST INSPECTION. IF YOU INTEND TO OBTAIN FINANCING, CONSULT WITH YOUR LENDER OR AN ATTORNEY BEFORE COMMENCING WORK OR RECORDING YOUR NOTICE OF COMMENCEMENT.

Under penalty of perjury, I declare that I have read the foregoing notice of commencement and that the facts stated in it are true to the best of my knowledge and belief.

[Signature] \_\_\_\_\_ Owner  
Signature of Owner or Lessee, or Owner's or Lessee's Authorized Officer/Director/Partner/Manager Signatory's Title/Office

The foregoing instrument was acknowledged before me this 15 day of Oct by Sonal Brito,  
month/year name of person

as Samantha T. Torres for Samantha T. Torres  
Type of authority, e.g., officer, trustee, attorney in fact Name of party on behalf of whom instrument was executed  
Signature of Notary Public - State of Florida Print, type, or stamp commissioned name of Notary Public

Personally Known \_\_\_\_\_ OR Produced ID   
Type of ID Produced Drivers License





# Approved Solar Energy System

Approval Date: FEB 2010

FSEC # S00170B

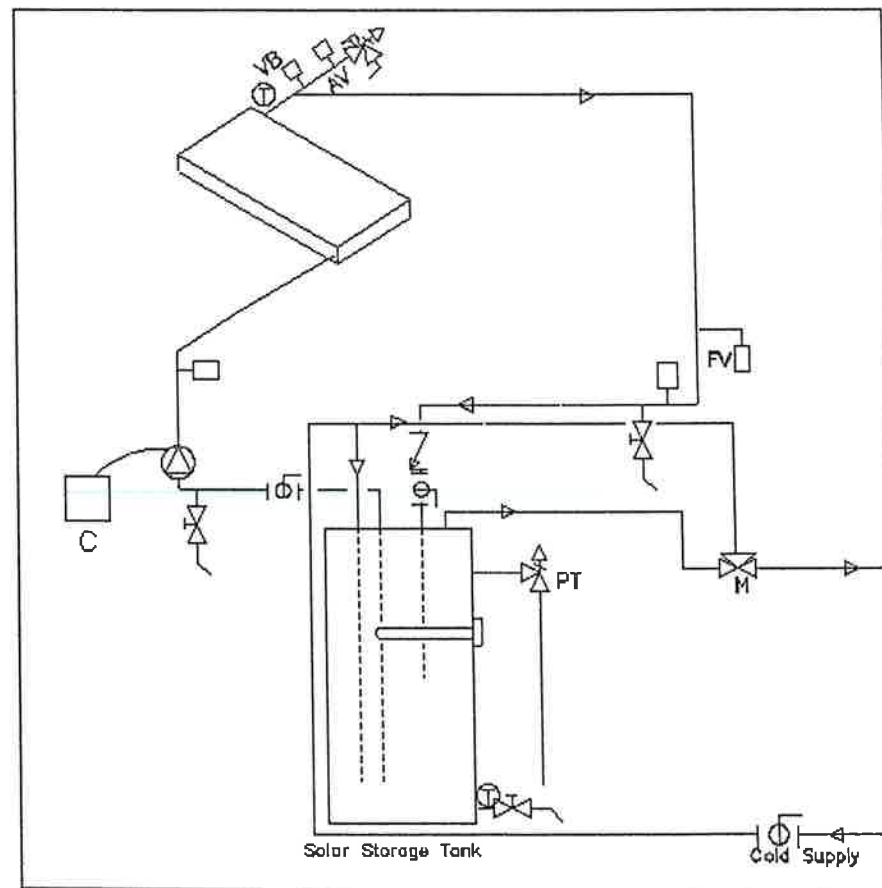

**CITY OF BELLE ISLE**  
 THE PLANS AND SPECIFICATIONS  
 HAVE BEEN REVIEWED. FULL  
 COMPLIANCE WITH CODES AND  
 REGULATIONS ARE REQUIRED BY  
 THE PERMIT HOLDER

APPROVED 





# Approved Solar Energy System

Approval Date: FEB 2010

FSEC # S00170B

## DISTRIBUTOR

Solene  
950 Sunshine Lane  
Altamonte Springs, Florida 32714

## SYSTEM

Solene/Aurora 40DC

This system was evaluated by the Florida Solar Energy Center (FSEC) in accordance with the Florida Standards Program for Solar Domestic Water and Pool Heating Systems (FSEC Standard 104-05) and was found to meet the minimum standards established by FSEC.

	North	Central	South
The calculated Florida Energy Factors for this system are:	3.2	3.5	3.5

## DESCRIPTION

Collector Manufacturer	Model Number	Units	Total Rating (Btu)
1. Solene	Solene/Aurora SLAR-40	1	37,900
2.			
3.			
4.			

Tank Manufacturer	Model Number	Capacity (gal)	Type: Direct
1. Lochinvar	FTA-082K	80	
2. Rheem	81RV80-1	80	
3. AO Smith	Sun 80	80	
4. Any Equivalent UL listed Tank		80	

Pump Manufacturer	Model Number	Power Draw (Watts)	Rated Power
1. TACO	006BC4	75	1/40 H.P.
2. March	809-BR	30	1/100 H.P.
3. Grundfos	UP1518	85	1/25 H.P.
4. Wilo	Star 8	50	1/25 H.P.

Controller Manufacturer	Model Number	Type: Differential controller
1. Goldline	GL-30	
2. Goldline	GL-30LCO	
3. STECA	TR0301U	

## Freeze Protection

- Freeze prevention valve
- Manual drain down

## CITY OF BELLE ISLE

## Other Major Components

- 
- 



THE PLANS AND SPECIFICATIONS  
HAVE BEEN REVIEWED. FULL  
COMPLIANCE WITH CODES AND  
REGULATIONS ARE REQUIRED BY  
THE PERMIT HOLDER

APPROVED 



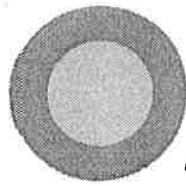

# EVERYTHING SOLAR

Division of Energy Solutions of Mid Florida  
email: [hello@poweredbydaylight.com](mailto:hello@poweredbydaylight.com)  
website: [www.poweredbydaylight.com](http://www.poweredbydaylight.com)

IRS Form 5695  
1901 W. Colonial Dr.  
Orlando, FL 32804  
407-545-3590 Office  
407-545-3589 Fax

Kelley Frasier  
487  
942 9459  
paperwork

State Certified CVC #56749

CUSTOMER <i>Sonal Suneeta Brito</i>	HOME PHONE	REP <i>BRAD</i>	DATE <i>9/12/14</i>
STREET ADDRESS <i>3921 Isle Vista Ave</i>	CELL PHONE <i>407 443-3704</i>	SOURCE <i>Archie Brito</i>	SUBDIVISION <i>Belle Vista</i>
CITY <i>ORL FL</i>	ZIP CODE <i>32812</i>	E-MAIL <i>Sonalbrito@gmail.com</i>	AUTOMATION TYPE <input type="checkbox"/> JVA
PRODUCT BRAND <i>Aurora 4x10 collector</i>	ROOF INFO <i>Panel Tile</i>	<input type="checkbox"/> POOL COVER CUT TO SHAPE	X
PRODUCT MODEL / SIZE <i>80 gallon Solar Tank</i>		<input type="checkbox"/> SPA COVER	X
OPTIONS / SPECIAL INSTRUCTIONS	<b>INSTALLATION DIRECTIVE</b>  <i>LEAVE existing tank with homeowner</i> 		
CONTROLS: <input type="checkbox"/> AUTO <input type="checkbox"/> MANUAL <input checked="" type="checkbox"/> MIXING VALVE <input checked="" type="checkbox"/> DIFFERENTIAL CONTROLLER <input type="checkbox"/> P.V. KW _____ INVERTER _____ PUMP UPGRADE NO <input type="checkbox"/> YES <input type="checkbox"/> _____ EXTRA PIPE: TRENCH <input type="checkbox"/> WALL <input type="checkbox"/> ROOF <input type="checkbox"/> FT _____			
LOCATION OF COLLECTORS <i>South roof</i>			

### PERFORMANCE GUARANTEE

Everything Solar has designed your pool heating system to add 12 to 15 degrees (F) to the unheated temperature of your pool, to keep your pool temperature at 80 degrees (F) or higher from approximately \_\_\_\_\_ to \_\_\_\_\_.

Your performance guarantee is based upon the last 20 years of weather data and your pool temperature will go up or down as the average weather increases or decreases. Your performance guarantee also assumes the use of a pool cover.

**90 Day Guarantee.** If we have not met the performance described above within 90 days from the original installation date of your system, we will modify the system to meet the performance guarantee at no additional cost to you. If we cannot meet the performance guarantee, we will refund 100% of your original investment.

**Buyer's Right to Cancel.** Florida law gives you the right to cancel this transaction, by giving us notice by certified or registered mail postmarked on or before midnight of the third business day following the effective date of this transaction.

**Acceptance.** I (we) have read this Agreement, including the information on the reverse side of this page, and I (we) acknowledge and accept its terms.

*[Signature]* Date *9/12/14*  
 Customer  
*[Signature]* Date *9/12/14*  
 Customer  
*[Signature]* Date *9/12/14*  
 Everything Solar Authorized Signature

Base System <i>DHW</i>	<i>5580</i>
Total Investment	<i>5580</i>
Deposit	
Balance Due	
Payment Method	<i>F</i>
Terms	
Requested Installation Date	<i>FRIDAY OCT 3rd</i>



**POWER OF ATTORNEY**

Date: 12-5-14

I hereby name and appoint Judith Morales of  
Everything Solar to be my lawful attorney in fact to sign  
on my behalf and/or to act for me and apply to the City of Belle Isle Division  
of Building Safety for a Plumbing/solar permit and to sign my name and do  
all things necessary to this appointment for the work being performed at:

LOT \_\_\_\_\_ SUBDIVISION 3E

ADDRESS 3633 Isle Vista Ave

[Signature]  
Signature of Person giving Permission

Brad Launs CVC 56749  
Type or Print Name of Certified Contractor and Contractor's License Number

[Signature]  
Signature of Certified Contractor

STATE OF FLORIDA  
COUNTY OF Seminole

The foregoing instrument was acknowledged before me this 5 day of December  
2014 By Brad Launs

Who is/are personally known to me  or has/have Produced \_\_\_\_\_  
as identification.

Samantha T Torres  
Name Typed, Printed or Stamped of Notary Public

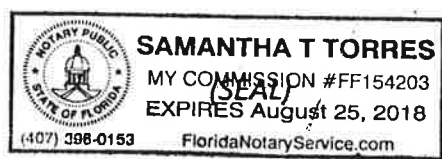

CITY OF ORLANDO

2013-2014

ECONOMIC DEVELOPMENT  
PERMITTING SERVICES

LOCAL BUSINESS TAX RECEIPT

(Formerly known as Business License, changed per state law HA 1269-2006)

Case Number: 15BUS002752

Business Name:

EVERETT HING SOCIETY  
30 COLONIAL DR  
ORLANDO FL 32804

Business Type:

CONTRACTOR DBFF



NOTICE-THIS RECEIPT ONLY EVIDENCES PAYMENT OF LOCAL BUSINESS TAX PURSUANT TO CH. 205, FLOR. STATUTES. IT DOES NOT PERMIT THE HOLDER TO OPERATE IN VIOLATION OF ANY CITY, STATE, OR FEDERAL LAW. NO PERMITTING MUST BE NOTIFIED OF ANY MATERIAL CHANGE TO THE INFORMATION FOUND HEREIN. BECAUSE THIS RECEIPT DOES NOT CONSTITUTE AN ENDORSEMENT OR APPROVAL OF THE HOLDER'S SKILL OR COMPETENCY.

Case Number: 15BUS002752

Business Owner:

ENERGY SOLUTIONS OF MID FLORIDA INC  
BRAD LAUNE CVC58749

Business Location:

1901 W. Colonial Dr  
Orlando, FL 32805

Administration Fee

2014 Business Tax

Total Paid

RICK SCOTT, GOVERNOR

KEN LAWSON, SECRETARY

STATE OF FLORIDA  
DEPARTMENT OF BUSINESS AND PROFESSIONAL REGULATION  
CONSTRUCTION INDUSTRY LICENSING BOARD



LICENSE NUMBER

CVC56749

The SOLAR CONTRACTOR  
Named below IS CERTIFIED  
Under the provisions of Chapter 489 FS.  
Expiration date: AUG 31, 2016

LAUNS, BRAD R.  
EVERYTHING SOLAR  
1901 W. COLONIAL DR  
ORLANDO FL 32804

ISSUED: 06/11/2014

DISPLAY AS REQUIRED BY LAW

SEQ.# L1406110001115



JEFF ATWATER  
CHIEF FINANCIAL OFFICER

STATE OF FLORIDA  
DEPARTMENT OF FINANCIAL SERVICES  
DIVISION OF WORKERS' COMPENSATION

**\*\* CERTIFICATE OF ELECTION TO BE EXEMPT FROM FLORIDA WORKERS' COMPENSATION LAW \*\***

**CONSTRUCTION INDUSTRY EXEMPTION**

This certifies that the individual listed below has elected to be exempt from Florida Workers' Compensation law.

**EFFECTIVE DATE:** 11/26/2014      **EXPIRATION DATE:** 11/25/2016

**PERSON:** LAUNS      BRAD

**FEIN:** 593607100

**BUSINESS NAME AND ADDRESS:**

ENERGY SOLUTIONS OF MID FLORIDA INC

EVERYTHING SOLAR

1901 W COLONIAL DR

ORLANDO      FL      32804

**SCOPES OF BUSINESS OR TRADE:**

ROOFING - ALL KINDS  
AND DRIVER

Pursuant to Chapter 440.05(14), F.S., an officer of a corporation who elects exemption from this chapter by filing a certificate of election under this section may not recover benefits or compensation under this chapter. Pursuant to Chapter 440.05(12), F.S., Certificates of election to be exempt... apply only within the scope of the business or trade listed on the notice of election to be exempt. Pursuant to Chapter 440.05(13), F.S., Notices of election to be exempt and certificates of election to be exempt shall be subject to revocation if, at any time after the filing of the notice or the issuance of the certificate, the person named on the notice or certificate no longer meets the requirements of this section for issuance of a certificate. The department shall revoke a



**CERTIFICATE OF LIABILITY INSURANCE**

DATE (MM/DD/YYYY)  
11/20/2014

THIS CERTIFICATE IS ISSUED AS A MATTER OF INFORMATION ONLY AND CONFERS NO RIGHTS UPON THE CERTIFICATE HOLDER. THIS CERTIFICATE DOES NOT AFFIRMATIVELY OR NEGATIVELY AMEND, EXTEND OR ALTER THE COVERAGE AFFORDED BY THE POLICIES BELOW. THIS CERTIFICATE OF INSURANCE DOES NOT CONSTITUTE A CONTRACT BETWEEN THE ISSUING INSURER(S), AUTHORIZED REPRESENTATIVE OR PRODUCER, AND THE CERTIFICATE HOLDER.

IMPORTANT: If the certificate holder is an ADDITIONAL INSURED, the policy(ies) must be endorsed. If SUBROGATION IS WAIVED, subject to the terms and conditions of the policy, certain policies may require an endorsement. A statement on this certificate does not confer rights to the certificate holder in lieu of such endorsement(s).

PRODUCER Citrus Insurance Group, LLC 6675 Westwood Blvd., #350 Orlando, FL 32821	CONTACT NAME:	
	PHONE (A/C, No, Ext): (321) 202-2664	FAX (A/C, No): (321) 202-2661
E-MAIL ADDRESS:		
INSURER(S) AFFORDING COVERAGE		NAIC #
INSURER A : Maxum Indemnity Company		26743
INSURED  Everything Solar 1901 West Colonial Dr Orlando, FL 32804	INSURER B :	
	INSURER C :	
	INSURER D :	
	INSURER E :	
	INSURER F :	
	INSURER G :	

COVERAGES      CERTIFICATE NUMBER:      REVISION NUMBER:

THIS IS TO CERTIFY THAT THE POLICIES OF INSURANCE LISTED BELOW HAVE BEEN ISSUED TO THE INSURED NAMED ABOVE FOR THE POLICY PERIOD INDICATED. NOTWITHSTANDING ANY REQUIREMENT, TERM OR CONDITION OF ANY CONTRACT OR OTHER DOCUMENT WITH RESPECT TO WHICH THIS CERTIFICATE MAY BE ISSUED OR MAY PERTAIN, THE INSURANCE AFFORDED BY THE POLICIES DESCRIBED HEREIN IS SUBJECT TO ALL THE TERMS, EXCLUSIONS AND CONDITIONS OF SUCH POLICIES. LIMITS SHOWN MAY HAVE BEEN REDUCED BY PAID CLAIMS.

INSR LTR	TYPE OF INSURANCE	ADDL INSD	SUBR WVD	POLICY NUMBER	POLICY EFF (MM/DD/YYYY)	POLICY EXP (MM/DD/YYYY)	LIMITS
A	<input checked="" type="checkbox"/> COMMERCIAL GENERAL LIABILITY <input type="checkbox"/> CLAIMS-MADE <input checked="" type="checkbox"/> OCCUR  GEN'L AGGREGATE LIMIT APPLIES PER: <input checked="" type="checkbox"/> POLICY <input type="checkbox"/> PRO-JECT <input type="checkbox"/> LOC OTHER:			BDG006440003	03/13/2014	03/13/2015	EACH OCCURRENCE \$ 2,000,000 DAMAGE TO RENTED PREMISES (Ea occurrence) \$ 100,000 MED EXP (Any one person) \$ 5,000 PERSONAL & ADV INJURY \$ 2,000,000 GENERAL AGGREGATE \$ 2,000,000 PRODUCTS - COMP/OP AGG \$ 2,000,000
	AUTOMOBILE LIABILITY <input type="checkbox"/> ANY AUTO <input type="checkbox"/> ALL OWNED AUTOS <input type="checkbox"/> SCHEDULED AUTOS <input type="checkbox"/> HIRED AUTOS <input type="checkbox"/> NON-OWNED AUTOS						COMBINED SINGLE LIMIT (Ea accident) \$ BODILY INJURY (Per person) \$ BODILY INJURY (Per accident) \$ PROPERTY DAMAGE (Per accident) \$
	<input type="checkbox"/> UMBRELLA LIAB <input type="checkbox"/> OCCUR <input type="checkbox"/> EXCESS LIAB <input type="checkbox"/> CLAIMS-MADE DED RETENTION \$						EACH OCCURRENCE \$ AGGREGATE \$
	WORKERS COMPENSATION AND EMPLOYERS' LIABILITY ANY PROPRIETOR/PARTNER/EXECUTIVE OFFICER/MEMBER EXCLUDED? (Mandatory in NH) If yes, describe under DESCRIPTION OF OPERATIONS below						<input type="checkbox"/> PER STATUTE <input type="checkbox"/> OTH-ER E.L. EACH ACCIDENT \$ E.L. DISEASE - EA EMPLOYEE \$ E.L. DISEASE - POLICY LIMIT \$

DESCRIPTION OF OPERATIONS / LOCATIONS / VEHICLES (ACORD 101, Additional Remarks Schedule, may be attached if more space is required)

CERTIFICATE HOLDER  City of Belle Isle 1600 Nela Ave Belle Isle, FL 32809	CANCELLATION  SHOULD ANY OF THE ABOVE DESCRIBED POLICIES BE CANCELLED BEFORE THE EXPIRATION DATE THEREOF, NOTICE WILL BE DELIVERED IN ACCORDANCE WITH THE POLICY PROVISIONS.  AUTHORIZED REPRESENTATIVE <i>NABurr</i>
---	--

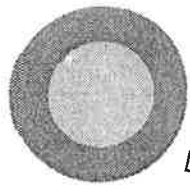

# EVERYTHING SOLAR

Division of Energy Solutions of Mid Florida

email: hello@poweredbydaylight.com

website: www.poweredbydaylight.com

IRS Form 5693

1901 W. Colonial Dr.

Orlando, FL 32804

407-545-3590 Office

407-545-3589 Fax

Kelley Frasier 942 9459 paperwork

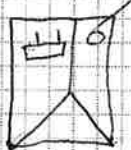

State Certified CVC #56749

CUSTOMER <i>Sonal Suneeta Brito</i>		HOME PHONE	REP <i>BRAD</i>	DATE <i>9/12/14</i>
STREET ADDRESS <i>3921 Isle Vista Ave</i>		CELL PHONE <i>407 443-3704</i>	SOURCE <i>Archie Brito</i>	SUBDIVISION <i>Belle Vista</i>
CITY <i>ORL FL</i>	ZIP CODE <i>32812</i>	E-MAIL <i>Sonalbrito@gmail.com</i>	AUTOMATION TYPE <input type="checkbox"/> JVA	
PRODUCT BRAND <i>Aurora 4x10 collector</i>		ROOF INFO <i>Panel Tile</i>	<input type="checkbox"/> POOL COVER CUT TO SHAPE X <input type="checkbox"/> SPA COVER X	
PRODUCT MODEL / SIZE <i>80 gallon Solar Tank</i>		INSTALLATION DIRECTIVE		
OPTIONS / SPECIAL INSTRUCTIONS		<p>THE PLANS AND SPECIFICATIONS HAVE BEEN REVIEWED. FULL COMPLIANCE WITH CODES AND REGULATIONS ARE REQUIRED BY THE PERMIT HOLDER.</p> <p><i>Leave existing tank with homeowner</i></p> 		
CONTROLS: <input type="checkbox"/> AUTO <input type="checkbox"/> MANUAL <input checked="" type="checkbox"/> MIXING VALVE <input checked="" type="checkbox"/> DIFFERENTIAL CONTROLLER				
<input type="checkbox"/> P.V. KW _____ INVERTER _____				
PUMP UPGRADE NO <input type="checkbox"/> YES <input type="checkbox"/> _____				
EXTRA PIPE: TRENCH <input type="checkbox"/> WALL <input type="checkbox"/> ROOF <input type="checkbox"/> FT _____				
LOCATION OF COLLECTORS <i>South roof</i>				

### PERFORMANCE GUARANTEE

Everything Solar has designed your pool heating system to add 12 to 15 degrees (F) to the unheated temperature of your pool, to keep your pool temperature at 80 degrees (F) or higher from approximately \_\_\_\_\_ to \_\_\_\_\_.

Your performance guarantee is based upon the last 20 years of weather data and your pool temperature will go up or down as the average weather increases or decreases. Your performance guarantee also assumes the use of a pool cover.

**90 Day Guarantee.** If we have not met the performance described above within 90 days from the original installation date of your system, we will modify the system to meet the performance guarantee at no additional cost to you. If we cannot meet the performance guarantee, we will refund 100% of your original investment.

**Buyer's Right to Cancel.** Florida law gives you the right to cancel this transaction, by giving us notice by certified or registered mail postmarked on or before midnight of the third business day following the effective date of this transaction.

**Acceptance.** I (we) have read this Agreement, including the information on the reverse side of this page, and I (we) acknowledge and accept its terms.

*[Signature]*  
Customer

Date *9/12/14*

*[Signature]*  
Customer

Date *9/12/14*

*[Signature]*  
Everything Solar Authorized Signature

Date *9/12/14*

Base System <i>DHW</i>	<i>5580</i>
Total Investment	<i>5580</i>
Deposit	
Balance Due	
Payment Method <i>F</i>	
Terms	
Requested Installation Date <i>FRIDAY OCT 3rd</i>	



# SOLENE COLLECTOR GENERAL NOTES:

1. APPLICABLE CODE: ASCE-7-10 MINIMUM DESIGN LOADS FOR BUILDING AND OTHER STRUCTURES COMPATIBLE WITH: 2010 FLORIDA BUILDING CODE.
2. BOLT SIZE AND EMBEDMENT LENGTHS ARE BASED PER 2005 EDITION "NATIONAL DESIGN SPECIFICATION FOR STRESS GRADE LUMBER AND FASTENINGS". ALL BOLT CAPACITIES ARE BASED ON A SOUTHERN YELLOW PINE (SYP) RESIDENTIAL MANUF. WOOD ROOF TRUSS AS EMBEDMENT MATERIAL.
3. ALL WIND DESIGN CRITERIA AND PARAMETERS ARE FOR HIP AND GABLE RESIDENTIAL ROOFS, CONSIDERING FROM A 7° TO A MAXIMUM 27° (2/12 TO A MAXIMUM 6/12 PITCH) ROOF IN SCHEDULE. BUILDING NOT TO EXCEED 30'-0" ROOF HEIGHT. CONTRACTOR RESPONSIBLE TO VERIFY ROOF SLOPE.
4. EACH GRIPPER SHALL BE FASTENED TO CHANNEL BRACKET WITH (1) 1/2" STAINLESS STEEL BOLT - NUT - WASHER PER CONNECTION. EACH CHANNEL BRACKET SHALL BE FASTENED TO ROOF TRUSS WITH (1) 3/8" DIA. A276 STAINLESS STEEL LAG BOLT. SEE SCHEDULE FOR LAG BOLT DESIGN EMBEDMENT.
5. ROOF SEALANTS SHALL CONFORM TO ASTM C920 AND ASTM 6511, AND IS THE RESPONSIBILITY OF THE CONTRACTOR TO PILOT FILL ALL HOLES.
6. THIS SHEET REFLECTS STRUCTURAL CONNECTIONS ONLY. REFER TO SOLENE INSTALLATION MANUAL FOR ALL MECHANICAL, ELECTRICAL, PLUMBING, AND SOLAR SPECS.
7. ALL LAG BOLTS THIS SHEET SHALL BE A276 STAINLESS STEEL UNLESS OTHERWISE SPECIFIED.
8. STRUCTURAL CONNECTIONS SPECS PER THIS SHEET APPLIES FOR ALL SOLENE AURORA COLLECTORS.
9. PLASTIC POLYMER PIPE RISER SHALL BE PROVIDED AS A SPACER FOR PIPE CLAMP FASTENING LOCATIONS.
10. CONTRACTOR SHALL ENSURE ALL ROOF PENETRATIONS TO BE INSTALLED AND SEALED PER 2010 FLORIDA BUILDING CODE OR LOCAL GOVERNING CODE.

NOTE: FOR TILE ROOFS, SOLENE GRIPPER MOUNT WITH LIFT KIT ASSEMBLY SHALL BE USED. ROOF DECKING NOT SHOWN FOR CLARITY. REFER TO SCHEDULE FOR REQUIRED COLLECTOR LAYOUT FOR EACH WIND SPEED.

ULTIMATE WIND SPEED V <sub>w</sub> (MPH)	V <sub>wd</sub> WIND PRESSURES ZONE 1 (PSF)	V <sub>wd</sub> WIND PRESSURES ZONE 2 (PSF)	V <sub>wd</sub> WIND PRESSURES ZONE 3* (PSF)	QUANTITY OF BOLTS - GRIPPERS PER COLLECTOR	EMBED. DEPTH REQ.	COLLECTOR LAYOUT
140	16.0, -19.9	16.0, -34.7	16.0, -51.3*	(4) 3/8" DIA. - (4) GRPR.	2" **	PORT., LAND.

-- PLUS AND MINUS SIGNS SIGNIFY PRESSURES ACTING TOWARD AND AWAY FROM SURFACES, RESPECTIVELY.  
 -- SCHEDULE REFLECTS COMPONENTS AND CLADDING (C&C) NOMINAL WIND SPEED PRESSURES WITH EXPOSURE "B", RISK CATEGORY II, ENCLOSED BUILDING AND h < 60'-0" PER ASCE 7-10 "MINIMUM DESIGN LOADS FOR BUILDING AND OTHER STRUCTURES" AND 2010 F.B.C.  
 -- MINIMUM V<sub>wd</sub> WIND PRESSURE SHALL BE 16.0 PSF AND -16.0 PSF PER ASCE 7-10 SECTION 30.2.2.  
 -- EFFECTIVE DESIGN WIND AREA IS 10 SF PER COLLECTOR.  
 \* INSTALLATION OF COLLECTORS MUST BE IN WIND ZONE 1 AND 2. WIND ZONE 3 INSTALLATION REQUIRES SITE SPECIFIC STRUCTURAL ENGINEER'S APPROVAL.  
 \*\* LAG BOLT DEPTH REQUIRED IN WOOD MEMBER EXCLUDING ANY ROOF DECKING.

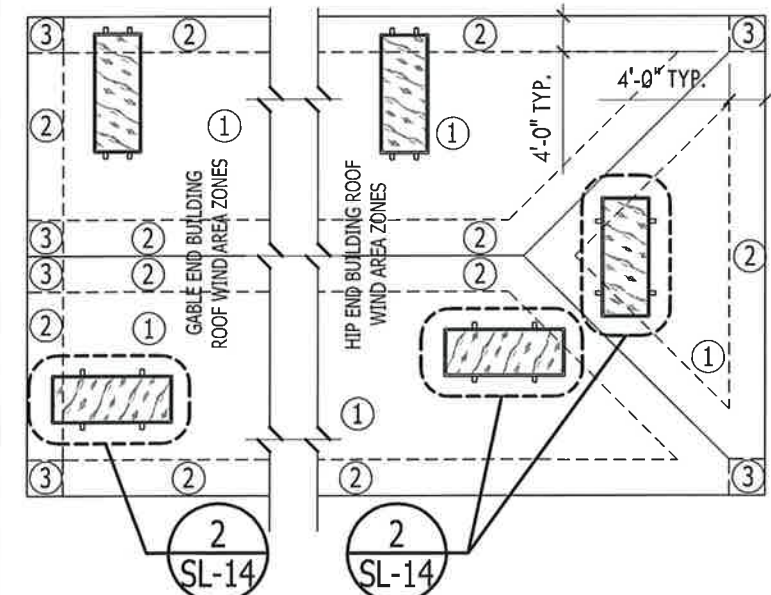

TYPICAL COLLECTOR PITCHED ROOF LAYOUT - WIND ZONES - SCHEDULE - PLAN

SCALE: NONE

1 SL-14

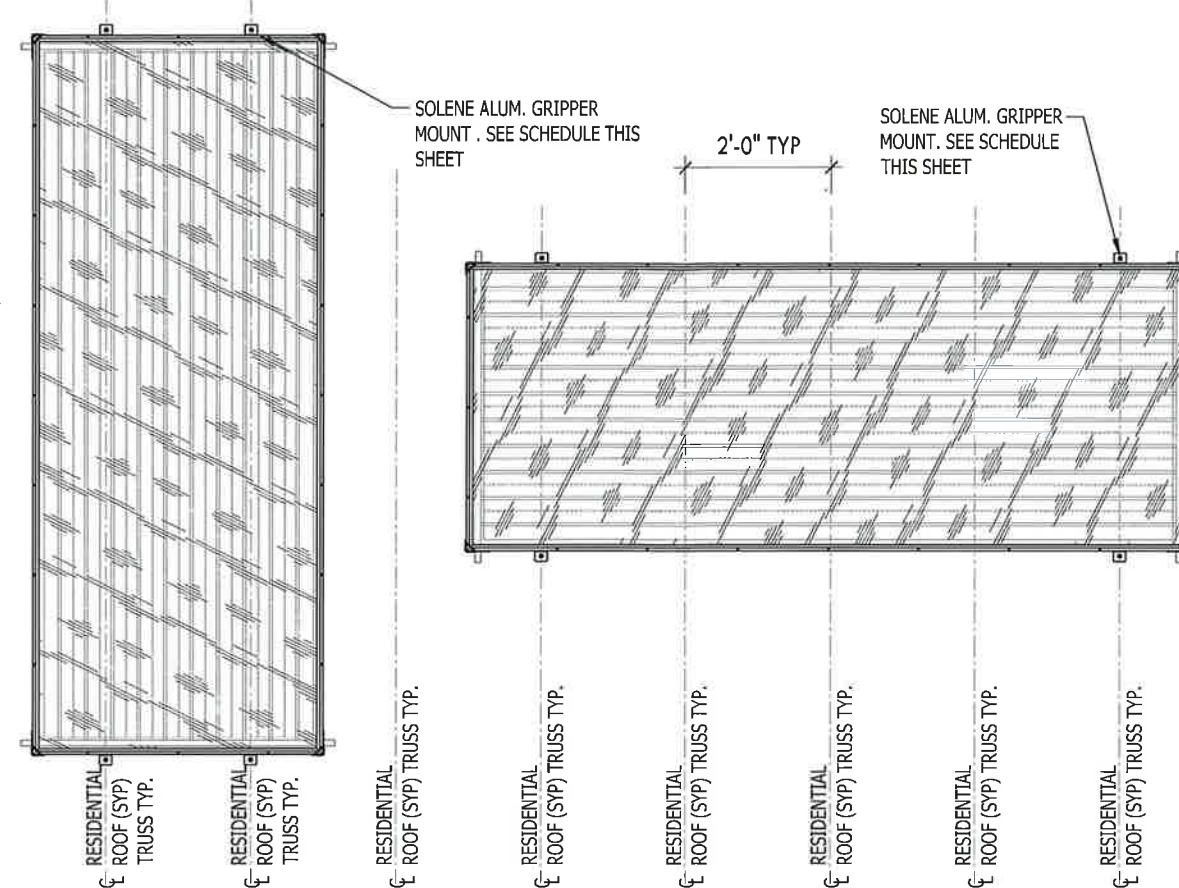

TYPICAL COLLECTOR ORIENTATIONS

SCALE: 3/8"=1'-0"

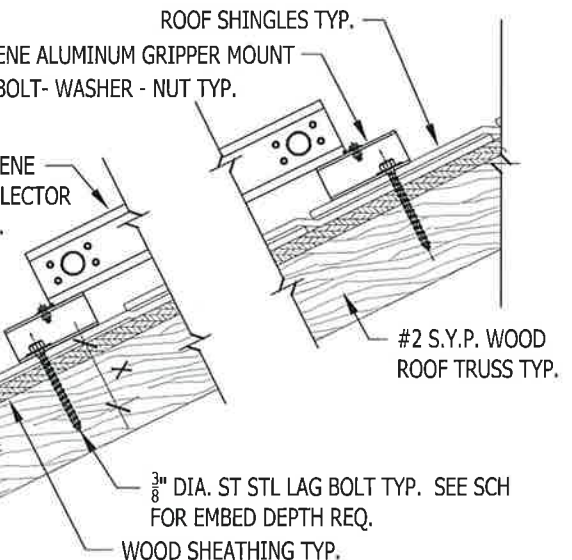

REFER TO SCHEDULE THIS SHEET FOR REQUIRED EMBEDMENT DEPTH LABELED "X" IN THIS DETAIL

TYPICAL ASPHALT/METAL SHINGLE CONNECTION DETAIL

SCALE: 1 1/2"=1'-0"

3 SL-14

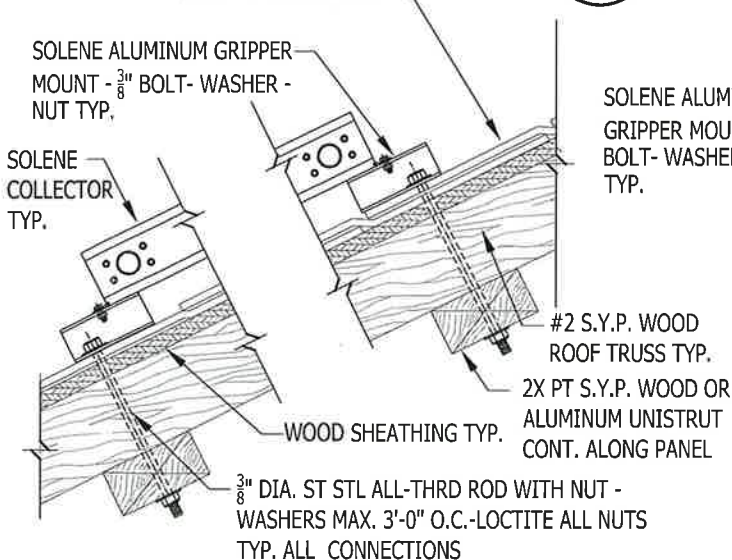

TYPICAL LIMITED SPACE OPTION CONNECTION DETAIL

SCALE: 1 1/2"=1'-0"

4 SL-14

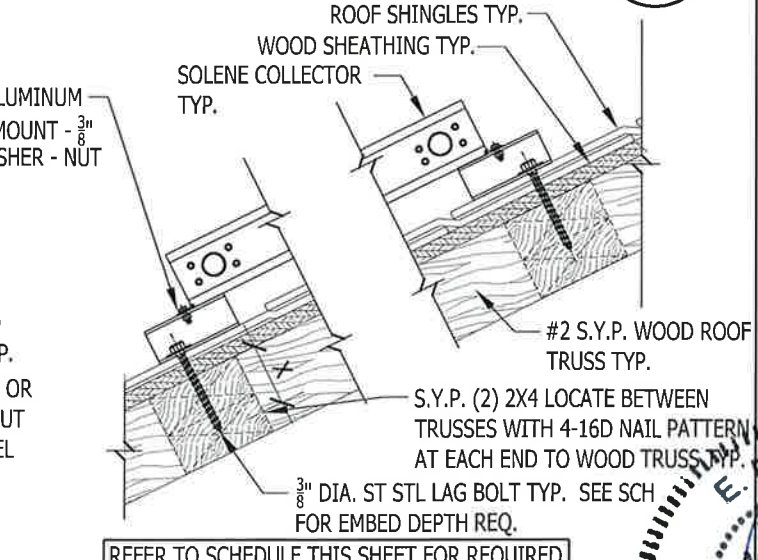

REFER TO SCHEDULE THIS SHEET FOR REQUIRED EMBEDMENT DEPTH LABELED "X" IN THIS DETAIL

TYPICAL WOOD SPANNER OPTION FOR UNALIGNED TRUSS - GRIPPER MOUNT CONNECTION DETAIL

SCALE: 1 1/2"=1'-0"

6 SL-14

TYPICAL FLAT TILE - BARREL TILE ROOF CONNECTION DETAIL

SCALE: 1 1/2"=1'-0"

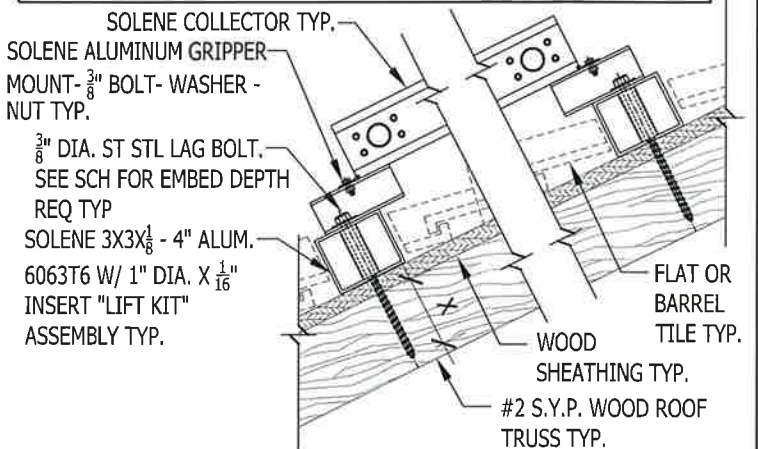

TYPICAL GRIPPER BOLT - FLUSH MOUNT DETAIL

SCALE: 3"=1'-0"

REFER TO SCHEDULE THIS SHEET FOR REQUIRED EMBEDMENT DEPTH LABELED "X" IN THIS DETAIL  
 CUT OUT OR REMOVE TILE TO INSTALL "LIFT KIT" ASSEMBLY. RE-INSTALL, RE-FILL AND RE-SEAL TILES AFFECTED WITH APPROVED ROOF MAT.

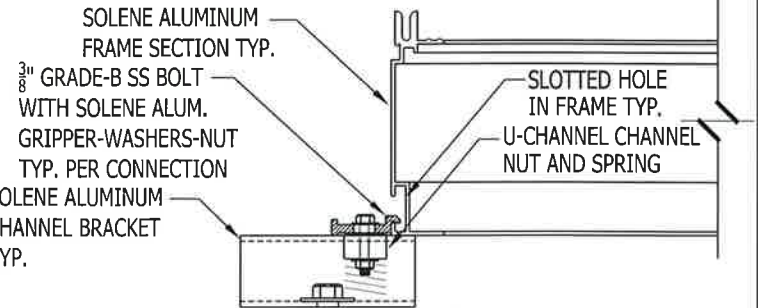

RC ENGINEERING, LLC. - COA 28345  
 PHONE: 407-474-9181 - FAX: 407-328-5397  
 2381 CREST RIDGE COURT  
 SANFORD, FL 32771  
 ERMOCRATES ENRIQUE CASTILLO, FL PE# 52590

---

PROJECT:

SOLENE AURORA - EXPOSURE B - PITCHED SHINGLE - TILE ROOF INSTALLATION PLAN AND DETAILS

NAME: ADDRESS:

---

DATE: 4-16-2014  
 DRAWN BY: JAT  
 CHKD BY: EEC  
 SCALE: AS NOTED

---

DRAWING #

Reviewed for Code Compliance  
 Universal Engineering Sciences