



City of Belle Isle Job Site Card **Roof PERMIT** 2020-04-028

PERMIT MUST BE POSTED ON SITE - A permit expires in 6 months if approved inspections are not recorded /scheduled within that time frame. You are responsible for scheduling and keeping track of all your inspections -

Site Address: 4232 Bell Tower Ct 32812

Parcel #:20-23-30-1618-00-620

Class: Residential

Subdivision: na

Description of Work: reroof 4600 sf with asphalt shingles

Number of Stories: 1

Issued To: GOLD KEY ROOFING LLC

Business Phone: 407 851-0680

Name: HEWITT, JEFFREY ALLAN

Roof Contractor License:

CCC1329157

Issued on Payment Date & Method:

4 / 10 2020

Picked up by

email

Emailed

Visa

Master Card

Amex

Discover

Check / Money Order #

4232

Schedule Inspections via Email at: BI DScheduling@universalengineering.com

SCHEDULE INSPECTIONS BY 3:00 PM CUT OFF TIME

Inspection Results Will Be Sent Out the Following Business Day

"WARNING TO OWNER: YOUR FAILURE TO RECORD A NOTICE OF COMMENCEMENT MAY RESULT IN YOUR PAYING TWICE FOR IMPROVEMENTS TO YOUR PROPERTY. IF YOU INTEND TO OBTAIN FINANCING, CONSULT WITH YOUR LENDER OR AN ATTORNEY BEFORE RECORDING YOUR NOTICE OF COMMENCEMENT."

ROOF	INSPECTOR	DATE	COMMENTS
NEW ROOFS ONLY Code 700 Deck Nailing, Dry-In, Flashing			This inspection only applies for a brand new roof only!
Both new & re-roof Code 710 In - Progress			This inspection consists of all underlayment/black paper coverage and only 25% shingle coverage.
Both new & re-roof Code 720 Final			After the In Progress has been passed, then the entire roof is covered with shingles.

Inspection requests are to be emailed to BI DScheduling@UniversalEngineering.com; a confirmation email will be sent back to you upon scheduling. **Next-Day Inspection requests must be made by 3:00 p.m.** Please include the following in your request: Permit #, project address, type of inspection, date of the requested inspection, a contact name & a contact phone number. AM or PM may be requested but cannot be guaranteed. **OSHA Approved Access to the Roof must be made Available to the Inspector.**



City of Belle Isle

Universal Engineering Sciences 3532 Maggie Blvd., Orlando, FL 32811
Tel 407-581-8161 * Fax 407-581-0313 * www.universaleengineering.com

RECEIVED
APR 06 2020

APPLICATION FOR ROOFING PERMIT

WARNING TO OWNER: YOUR FAILURE TO RECORD A NOTICE OF COMMENCEMENT MAY RESULT IN YOUR PAYING TWICE FOR IMPROVEMENTS TO YOUR PROPERTY. A NOTICE OF COMMENCEMENT MUST BE RECORDED AND POSTED ON THE JOB SITE BEFORE THE FIRST INSPECTION. IF YOU INTEND TO OBTAIN FINANCING, CONSULT WITH YOUR LENDER OR AN ATTORNEY BEFORE RECORDING YOUR NOTICE OF COMMENCEMENT.

DATE OF APPLICATION: 4-2-2020 ROOF PERMIT NUMBER 2020 04-028

PLEASE PRINT. The undersigned hereby applies for a permit to make installations as indicated below:

Project Address 4232 Bell Tower Ct, Belle Isle, FL 32809^X 32812

Property Owner Nicholas Garofalo Phone 407-230-6098

Property Owner's Mailing Address 4232 Bell Tower Ct City Orlando

State FL Zip Code 32812 Parcel Id Number: 20-23-30-1618-00-620

REQUIRED! To obtain this information, please visit <http://www.ocpaf1.org/Searches/ParcelSearch.aspx>

Class of Building: Old New Type of Building: Residential Commercial Other
Type of Work: New Roof ReRoof

• **REQUIRED!** Florida Product Approval Form – NOTE: installation instructions must be posted on-site before your first inspection!!

Please indicate the nature of work by completing the information below:

Roof Square Footage: 46 Number of Stories: 1 Job Valuation: \$ 16,250.00^{>15}

Type: Asphalt Shingles Metal Modified Bitumen Other: _____

I hereby certify that the above is true and correct to the best of my knowledge and make Application for Permit as outlined above, and if same is granted I agree to conform to all Florida Building Code Regulations and City Ordinances regulating same and in accordance with plans submitted. The issuance of this permit does not grant permission to violate any applicable Town and/or State of Florida codes and/or ordinances. By signing below, I recognize Republic Services is by legal contract the sole authorized provider of garbage, recycling, yard waste, and commercial garbage and construction debris collection and disposal services with the city limits of the City. Contractors, homeowners and commercial businesses may contact Republic Services at 407-293-8000 to setup accounts for Commercial, Construction Roll Off, or other services needed. Rates are fixed by contract and are available at City Hall or from Republic Services. The City enforces the contract through its code enforcement office. Failure to comply will result in a stop work order.

LICENSE HOLDER SIGNATURE [Signature] LICENSE # CCC1329157

LICENSE HOLDER NAME Jeffrey Hewitt COMPANY NAME Gold Key Roofing

Street Address 4874 S Orange Ave

City Orlando State FL Zip Code 32806 Phone Number 407-851-0680

Email Address Receptionist@goldkeyroofing.com

PAID USA 0767 4-10-20

Building Official: OTZ Date 4-8-20
Verified Contractor's Licenses & Insurance are on file [Signature] Date 4-8-20
NCC

Zoning Fee	\$ <u>30.-</u>
Building Fee	\$ <u>165.-</u>
Review Fee	\$ <u>0</u>
1% BCAIB Fee	\$ <u>2 min</u>
1.5% DCA Fee	\$ <u>2 min</u>
Total Permit Fee	\$ <u>139.00</u>

NOTE: The Building Permit Number is required if the Roof Installation is associated with any construction or alteration where a Building Permit has been issued.

151 IK
5x16
25
80
105

Building Permit Number _____

Permit Number: 2006 04-028
 Folio/Parcel ID #: 20-23-30-1618-00-620
 Prepared by: Gold Key Roofing
4874 S Orange Ave
Orlando, FL 32806
 Return to: Gold Key Roofing
4874 S Orange Ave
Orlando, FL 32806

DOC # 20200212733
 04/02/2020 14:03 PM Page 1 of 1
 Rec Fee: \$10.00
 Deed Doc Tax: \$0.00
 Mortgage Doc Tax: \$0.00
 Intangible Tax: \$0.00
 Phil Diamond, Comptroller
 Orange County, FL
 Ret To: SIMPLIFILE LC

NOTICE OF COMMENCEMENT

State of Florida, County of Orange

The undersigned hereby gives notice that improvement will be made to certain real property, and in accordance with Chapter 713, Florida Statutes, the following information is provided in this Notice of Commencement.

1. Description of property (legal description of the property, and street address if available)
Conway Groves Unit 1 36/3 lot 62 4232 Bell Tower Ct
2. General description of improvement
ReRoof
3. Owner information or Lessee information if the Lessee contracted for the improvement
 Name Nicholas Garofalo
 Address 4232 Bell Tower Ct Orlando FL 32812
 Interest in Property owner
 Name and address of fee simple titleholder (if different from Owner listed above)
 Name N/A
 Address N/A
4. Contractor
 Name Gold Key Roofing Telephone Number 407-851-0680
 Address 4874 S Orange Ave Orlando, FL 32806
5. Surety (if applicable, a copy of the payment bond is attached)
 Name N/A Telephone Number N/A
 Address N/A Amount of Bond \$ N/A
6. Lender
 Name N/A Telephone Number N/A
 Address N/A
7. Persons within the State of Florida designated by Owner upon whom notices or other documents may be served as provided by §713.13(1)(a)7, Florida Statutes.
 Name N/A Telephone Number N/A
 Address N/A
8. In addition to himself or herself, Owner designates the following to receive a copy of the Lienor's Notice as provided in §713.13(1)(b), Florida Statutes.
 Name N/A Telephone Number N/A
 Address N/A
9. Expiration date of notice of commencement (the expiration date may not be before the completion of construction and final payment to the contractor, but will be 1 year from the date of recording unless a different date is specified) N/A

WARNING TO OWNER: ANY PAYMENTS MADE BY THE OWNER AFTER THE EXPIRATION OF THE NOTICE OF COMMENCEMENT ARE CONSIDERED IMPROPER PAYMENTS UNDER CHAPTER 713, PART I, SECTION 713.13, FLORIDA STATUTES, AND CAN RESULT IN YOUR PAYING TWICE FOR IMPROVEMENTS TO YOUR PROPERTY. A NOTICE OF COMMENCEMENT MUST BE RECORDED AND POSTED ON THE JOB SITE BEFORE THE FIRST INSPECTION. IF YOU INTEND TO OBTAIN FINANCING, CONSULT WITH YOUR LENDER OR AN ATTORNEY BEFORE COMMENCING WORK OR RECORDING YOUR NOTICE OF COMMENCEMENT.

Signature of Owner or Lessee, or Owner's or Lessee's Authorized Officer/Director/Partner/Manager _____ Owner
 Signatory's Title/Office _____

The foregoing instrument was acknowledged before me this 1 day of April by Nicholas Garofalo
 month/year name of person

as owner for owner
 Type of authority, e.g., officer, trustee, attorney in fact Name of party on behalf of whom instrument was executed
Rachel A. Krantz Crane
 Signature of Notary Public - State of Florida Print, type, or stamp commissioned name of Notary Public

Personally Known OR Produced ID +
 Type of ID Produced FLDC



Form content revised: 10/17/12

State of FLORIDA, County of ORANGE.
 Per §688.50, F.S., which defines and permits electronic signatures, I certify that this is a true copy of the document as reflected in the Official Records.
PHIL DIAMOND, COUNTY COMPTROLLER
 Katherine Maier 04/06/2020 Date
 Deputy Comptroller _____





City of Belle Isle

Universal Engineering Sciences 3532 Maggie Blvd., Orlando, FL 32811
 Tel 407-581-8161 * Fax 407-581-0313 * www.universalengineering.com

Product Approval Form

DATE: 4-2-2020

PERMIT # 2020-04-028

PROJECT ADDRESS 4732 Bell Tower Ct

Belle Isle, FL 32809 ~~X~~32812

As required by Florida Statue 553.842 and Florida Administrative Code 9B-72m, please provide the information and approval numbers of the building components listed below if they will be utilized on the building or structure. FL Approved products are listed online at www.floridabuilding.org or can be obtained from the local product supplier. The following information must be turned in with permit application and available onsite for inspections:

• **NOTE: The installation instructions must be posted on-site before your first inspection!!**

Product Type	Manufacturer	Model/Series	FL Product Approval #	Product Type	Manufacturer	Model/Series	FL Product Approval #
EXTERIOR DOORS				WALL PANELS			
Swinging				Sliding			
Sliding				Soffits			
Sectional/Rollup				Storefront			
Other				Glass Block			
				Other			
WINDOWS				ROOFING PRODUCTS			
Single/Dbl Hung				Asphalt Shingles	<u>Certainteed</u>		<u>FL5444-R15</u>
Horizontal Slider				Non Struct Metal			
Casement				Roofing Tiles			
Fixed				Single Ply Roof			
Mullion				Underlayment	<u>Certainteed</u>		<u>FL-21841-R5</u>
Skylights				Other			
Other							
STRUCTURAL COMPONENTS				OTHER			
Wood Connectors							
Wood Anchors							
Truss Plates							
Insulation Forms							
Lintels							
Other							

It is the applicant's responsibility to verify that specific products have been installed in accordance with their limitations and with the minimum required design pressures for the structure. Specific compliance will be verified during field inspections.

Applicant Signature 

Date 4-2-2020



Product Approval
USER: Public User

[Product Approval Menu](#) > [Product or Application Search](#) > [Application List](#) > **Application Detail**

OFFICE OF THE
SECRETARY

FL #	FL5444-R15								
Application Type	Revision								
Code Version	2017								
Application Status	Approved								
Comments									
Archived	<input type="checkbox"/>								
Product Manufacturer	CertainTeed Corporation-Roofing								
Address/Phone/Email	20 Moores Road Malvern, PA 19355 (610) 893-5400 mark.d.harner@saint-gobain.com								
Authorized Signature	Mark Harner mark.d.harner@saint-gobain.com								
Technical Representative	Mark D. Harner								
Address/Phone/Email	18 Moores Road Malvern, PA 19355 (610) 651-5847 Mark.D.Harner@saint-gobain.com								
Quality Assurance Representative									
Address/Phone/Email									
Category	Roofing								
Subcategory	Asphalt Shingles								
Compliance Method	Evaluation Report from a Florida Registered Architect or a Licensed Florida Professional Engineer <input type="checkbox"/> Evaluation Report - Hardcopy Received								
Florida Engineer or Architect Name who developed the Evaluation Report	Robert Nieminen								
Florida License	PE-59166								
Quality Assurance Entity	UL LLC								
Quality Assurance Contract Expiration Date	11/13/2022								
Validated By	John W. Knezevich, PE <input checked="" type="checkbox"/> Validation Checklist - Hardcopy Received								
Certificate of Independence	FL5444 R15 COI 2019 01 COI NIEMINEN.pdf								
Referenced Standard and Year (of Standard)	<table border="0"> <thead> <tr> <th><u>Standard</u></th> <th><u>Year</u></th> </tr> </thead> <tbody> <tr> <td>ASTM D3161</td> <td>2016</td> </tr> <tr> <td>ASTM D3462</td> <td>2010</td> </tr> <tr> <td>ASTM D7158</td> <td>2011</td> </tr> </tbody> </table>	<u>Standard</u>	<u>Year</u>	ASTM D3161	2016	ASTM D3462	2010	ASTM D7158	2011
<u>Standard</u>	<u>Year</u>								
ASTM D3161	2016								
ASTM D3462	2010								
ASTM D7158	2011								
Equivalence of Product Standards Certified By									
Sections from the Code									

Product Approval Method

Method 1 Option D

Date Submitted

08/14/2019

Date Validated

08/14/2019

Date Pending FBC Approval

08/17/2019

Date Approved

10/15/2019

Summary of Products

FL #	Model, Number or Name	Description
5444.1	CertainTeed Asphalt Roof Shingles	3-tab, 4-tab, strip (no-cut-outs), laminated and architectural asphalt roof shingles
Limits of Use Approved for use in HVHZ: No Approved for use outside HVHZ: Yes Impact Resistant: N/A Design Pressure: N/A Other: Refer to ER Section 5 for Limits of Use		Installation Instructions FL5444 R15 II 2019 08 FINAL ER CERTAINTEED FL5444-R15.pdf Verified By: Robert Nieminen, PE PE-59166 Created by Independent Third Party: Yes Evaluation Reports FL5444 R15 AE 2019 08 FINAL ER CERTAINTEED FL5444-R15.pdf Created by Independent Third Party: Yes

[Back](#)

[Next](#)

Contact Us :: [2601 Blair Stone Road, Tallahassee FL 32399](#) Phone: 850-487-1824

The State of Florida is an AA/EEO employer. [Copyright 2007-2013 State of Florida.](#) :: [Privacy Statement](#) :: [Accessibility Statement](#) :: [Refund Statement](#)

Under Florida law, email addresses are public records. If you do not want your e-mail address released in response to a public-records request, do not send electronic mail to this entity. Instead, contact the office by phone or by traditional mail. If you have any questions, please contact 850.487.1395. *Pursuant to Section 455.275(1), Florida Statutes, effective October 1, 2012, licensees licensed under Chapter 455, F.S. must provide the Department with an email address if they have one. The emails provided may be used for official communication with the licensee. However email addresses are public record. If you do not wish to supply a personal address, please provide the Department with an email address which can be made available to the public. To determine if you are a licensee under Chapter 455, F.S., please click [here](#).

Product Approval Accepts:



Credit Card
Safe





NEMO|etc.

Certificate of Authorization #32455
353 Christian Street, Unit #13
Oxford, CT 06478
(203) 262-9245

ENGINEER

EVALUATE

TEST

CONSULT

CERTIFY

EVALUATION REPORT

CertainTeed Corporation

20 Moores Road
Malvern, PA 19355
(610) 651-5847

Evaluation Report 3532.09.05-R16

FL5444-R15

Date of Issuance: 09/22/2005

Revision 16: 08/14/2019

SCOPE:

This Evaluation Report is issued under **Rule 61G20-3** and the applicable rules and regulations governing the use of construction materials in the State of Florida. The documentation submitted has been reviewed by Robert Nieminen, P.E. for use of the product under the Florida Building Code and Florida Building Code, Residential Volume. The products described herein have been evaluated for compliance with the **6th Edition (2017) Florida Building Code** sections noted herein.

DESCRIPTION: CertainTeed Asphalt Roof Shingles.

LABELING: Labeling shall be in accordance with the requirements of the Accredited Quality Assurance Agency noted herein and **FBC 1507.2.7.1 / R905.2.6.1**

CONTINUED COMPLIANCE: This Evaluation Report is valid until the named product(s) changes, the referenced Quality Assurance documentation changes, or provisions of the Code that relate to the product change. Acceptance of this Evaluation Report by the named client constitutes agreement to notify Robert Nieminen, P.E. of any changes to the product(s), the Quality Assurance or the production facility location(s). NEMO|etc. requires a complete review of this Evaluation Report relative to updated Code requirements with each Code Cycle.

ADVERTISEMENT: The Evaluation Report number preceded by the words "NEMO|etc. Evaluated" may be displayed in advertising literature. If any portion of the Evaluation Report is displayed, then it shall be done in its entirety.

INSPECTION: Upon request, a copy of this entire Evaluation Report shall be provided to the user by the manufacturer or its distributors and shall be available for inspection at the job site at the request of the Building Official.

This Evaluation Report consists of pages 1 through 15.

Prepared by:

Robert J.M. Nieminen, P.E.

Florida Registration No. 59166, Florida DCA ANE1983



The facsimile seal appearing was authorized by Robert Nieminen, P.E. on 08/14/2019. This does not serve as an electronically signed document.

CERTIFICATION OF INDEPENDENCE:

1. NEMO|etc. does not have, nor does it intend to acquire, or will it acquire, a financial interest in any company manufacturing or distributing products it evaluates.
2. NEMO|etc. is not owned, operated or controlled by any company manufacturing or distributing products it evaluates.
3. Robert Nieminen, P.E. does not have nor will acquire, a financial interest in any company manufacturing or distributing products for which the evaluation reports are being issued.
4. Robert Nieminen, P.E. does not have, nor will acquire, a financial interest in any other entity involved in the approval process of the product.
5. This is a building code evaluation. Neither NEMO|etc. nor Robert Nieminen, P.E. are, in any way, the Designer of Record for any project on which this Evaluation Report, or previous versions thereof, is/was used for permitting or design guidance unless retained specifically for that purpose.



ROOFING SYSTEMS EVALUATION:

1. SCOPE:

Product Category: Roofing
Sub-Category: Asphalt Shingles

Compliance Statement: CertainTeed Asphalt Roof Shingles, as produced by CertainTeed Corporation, have demonstrated compliance with the following sections of the 6th Edition (2017) Florida Building Code and 6th Edition (2017) Florida Building Code, Residential Volume through testing in accordance with the following Standards. Compliance is subject to the Installation Requirements and Limitations / Conditions of Use set forth herein.

2. STANDARDS:

Table with 4 columns: Section, Property, Standard, Year. Rows include 1507.2.5, R905.2.4; 1507.2.7.1, R905.2.6.1; 1507.2.7.1, R905.2.6.1.

3. REFERENCES:

Table with 4 columns: Entity, Examination, Reference, Date. Lists various testing entities like PRI, UL, and UL LLC with their corresponding standards and test dates.



4. PRODUCT DESCRIPTION:

4.1 Asphalt Shingles:

- 4.1.1 CT20™, XT™ 25, XT™ 30 and XT™ 30 IR are fiberglass reinforced, 3-tab asphalt roof shingles.
- 4.1.2 Arcadia™, Belmont®, Belmont® IR, Carriage House Shingle®, Grand Manor Shangle®, Landmark™, Landmark™ IR, Landmark™ Pro, Landmark™ Pro Solaris, Landmark™ Premium, Landmark™ TL, Landmark™ Solaris, Landmark™ Solaris IR and Landmark™ Solaris Gold/Platinum are fiberglass reinforced, laminated asphalt roof shingles.
- 4.1.3 NorthGate™ is a fiberglass reinforced, laminated, SBS modified bitumen roof shingle.
- 4.1.4 Presidential Shake™, Presidential Shake™ IR, Presidential Shake TL™ and Presidential Solaris™ are fiberglass reinforced, architectural asphalt roof shingles.
- 4.1.5 Hatteras™, Highland Slate™ and Highland Slate™ IR are fiberglass reinforced, 4-tab asphalt roof shingles.
- 4.1.6 Patriot™ is a fiberglass reinforced asphalt roof strip-shingle (with no cut-outs) providing a laminated appearance through an intermittent shadow line with contrasting blend drops for color definition.

4.2 Hip & Ridge Shingles:

- 4.2.1 Presidential Accessory, Accessory for Hatteras, Shangle Ridge™, Shadow Ridge™, Cedar Crest™, Cedar Crest™ IR, NorthGate Ridge and NorthGate Accessory are fiberglass reinforced accessory shingles for hip and ridge installation.

4.3 Accessory Starter Strips:

- 4.3.1 High-Performance Starter is a starter shingle, measuring 10" x 36", comprised of a fiber glass mat base and ceramic-coated mineral granules embedded in asphalt. These starter shingles are designed for use with Grand Manor Shangle®, Hatteras™ and Highland Slate™.
- 4.3.2 Presidential Starter is a starter shingle, measuring 13-1/4" x 40" (overall), comprised of a fiber glass mat base and ceramic-coated mineral granules embedded in asphalt with a reinforcement on its underside (for impact resistance considerations). These starter shingles, applied using two (2) overlapping layers, are designed for use with Presidential Shake™ and Presidential Shake TL™.
- 4.3.3 Presidential Starter IR is a starter shingle, measuring 13-1/4" x 40" (overall), comprised of a fiber glass mat base and ceramic-coated mineral granules embedded in asphalt. These starter shingles, applied using two (2) overlapping layers, are designed for use with Presidential Shake™ IR.
- 4.3.4 SwiftStart® Starter Shingle is a starter strip for asphalt roof shingles. Its overall size of 15-1/4" x 38-3/4" yields two (2) 7-5/8" x 38-3/4" starter pieces per shingle.
- 4.3.5 Universal Starter is a starter shingle, measuring 7" x 36" (overall), comprised of a fiber glass mat base and ceramic-coated mineral granules embedded in asphalt. These starter shingles are designed for use with any CertainTeed shingle measuring 12" x 36" having a weather exposure ≤ 5".
- 4.4 Any of the above listed shingles may be produced in AR (algae resistant) versions.

5. LIMITATIONS:

- 5.1 This is a building code evaluation. Neither NEMO|etc. nor Robert Nieminen, P.E. are, in any way, the Designer of Record for any project on which this Evaluation Report, or previous versions thereof, is/was used for permitting or design guidance unless retained specifically for that purpose.
- 5.2 This Evaluation Report is not for use within FBC HVHZ jurisdictions.
- 5.3 Fire Classification is not part of this Evaluation Report; refer to current Approved Roofing Materials Directory for fire ratings of this product.



- 5.4 **Wind Classification:**
- 5.4.1 All shingles noted herein are Classified in accordance with **FBC Tables 1507.2.7.1** and **R905.2.6.1** to **ASTM D3161, Class F** and/or **ASTM D7158, Class H**, indicating the shingles are acceptable for use in all wind zones up to $V_{asd} = 150$ mph ($V_{ult} = 194$ mph). Refer to Section 6 for installation requirements to meet this wind rating.
- 5.4.2 **Presidential Accessory, Accessory for Hatteras, Shangle Ridge, Shadow Ridge, Cedar Crest, NorthGate Ridge and NorthGate Accessory hip & ridge shingles** have been evaluated in accordance with **ASTM D3161, Class F**. All except Shadow Ridge (produced in Oxford, NC), NorthGate Ridge and NorthGate Accessory require use of **BASF Sonolastic NP 1 adhesive** or **Henkel PL® Polyurethane Roof & Flashing Sealant**, applied as specified in manufacturer's application instructions, for use in wind zones up to $V_{asd} = 150$ mph ($V_{ult} = 194$ mph). Refer to Section 6 for installation requirements to meet this wind rating.
- 5.4.3 **High-Performance Starter, Presidential Starter, Presidential Starter IR, SwiftStart® Starter Shingle and Universal Starter** have been evaluated in accordance with **ASTM D3161, Class F**. Refer to Section 6 for installation requirements to meet this wind rating.
- 5.4.3.1 **High-Performance Starter** shingles are limited to use with **Grand Manor Shangle®, Hatteras™** and **Highland Slate™** shingles.
- 5.4.3.2 **Presidential Starter** shingles must be applied using two (2) overlapping layers and are limited to use with **Presidential Shake™** and **Presidential Shake TL™** shingles.
- 5.4.3.3 **Presidential Starter IR** shingles must be applied using two (2) overlapping layers and are limited to use with **Presidential Shake™ IR** shingles.
- 5.4.3.4 **Universal Starter** shingles are limited to use with CertainTeed shingles measuring 12" x 36" having a weather exposure $\leq 5"$.
- 5.4.4 Classification by **ASTM D7158** applies to **exposure category B or C** and a **building height of 60 feet or less**. Calculations by a qualified design professional are required for conditions outside these limitations. Contact the shingle manufacturer for data specific to each shingle.
- 5.4.4.1 **Analysis in accordance with ASTM D7158** indicates the measured uplift resistance (R_T) for the CertainTeed asphalt Roof shingles listed in Section 4.1.1 through 4.1.6 (*except Presidential Solaris™, Landmark™ Pro Solaris and Landmark™ Solaris Gold/Platinum*) exceeds the calculated uplift force (F_T) at a maximum design wind speed of $V_{asd} = 150$ mph ($V_{ult} = 194$ mph) for residential buildings located in **Exposure D conditions with no topographical variations (flat terrain)** having a **mean roof height less than or equal to 60 feet**. The shingles are permissible under Code for installation in these conditions using the installation procedures detailed in this Evaluation Report and CertainTeed minimum requirements, subject to minimum codified fastening requirements established within any local jurisdiction, which shall take precedence.
- 5.5 All products in the roof assembly shall have quality assurance audits in accordance with **FAC Rule 61G20-3**.



6. INSTALLATION:

- 6.1 Roof deck, slope, underlayment and fasteners shall comply with **FBC 1507.2 / R905.2** and the shingle manufacturer's minimum requirements.
- 6.1.1 Underlayment shall be acceptable to **CertainTeed Corporation** and shall hold current Florida Statewide Product Approval, or be Locally Approved per **Rule 61G20-3**, per **FBC Sections 1507.2.3, 1507.2.4 or R905.2.3**.
- 6.2 Installation of asphalt shingles shall comply with the **CertainTeed Corporation** current published instructions, using minimum four (4) nails per shingle in accordance with **FBC 1507.2.7 or Section R905.2.6** and the minimum requirements herein.
- 6.2.1 Fasteners shall be in accordance with manufacturer's published requirements, but not less than **FBC 1507.2.6 or R905.2.5**. Staples are not permitted.
- 6.2.2 Where the roof slope exceeds 21 units vertical in 12 units horizontal, use the "Steep Slope" directions.
- 6.3 CertainTeed asphalt shingles are acceptable for use in reroof (tear-off) or recover applications, subject to the limitations set forth in **FBC Section 1511 or R908** and CertainTeed published installation instructions.

6.4 HIGH-PERFORMANCE STARTER:

- 6.4.1 Eaves: For the first starter shingle in each roof corner, use five (5) nails as shown below. All other starter shingles require four (4) nails per shingle. Nails must be of sufficient length to penetrate into the deck 3/4" or through the thickness of the decking, whichever is less. Nails are to be 11 or 12 gauge, corrosion-resistant roofing nails with 3/8" heads. Apply the 10" starter shingle with its factory-applied sealant stripes at the shingle's lower-most edge and nail firmly into the roof deck as near as possible *(maximum 3") to the eaves edge while avoiding the sealant. With the starter shingle well fastened to the deck and the sealant low on the starter shingle, it can firmly adhere to the first course shingles. *If nailing within 3" is not possible, nail as closely as possible, then lift and adhere the starter shingle to the underlayment and to the supporting structure with CertainTeed FlintBond™ Asphalt Roofing Cement-Caulk Grade, or approved equal.

Rakes: Prior to installation of the field shingles, starter shingles may be applied up the slope along the rake edge with sealant edge placed closest to the rake edge. Fasten as indicated below.

HIGH-PERFORMANCE STARTER SHINGLES

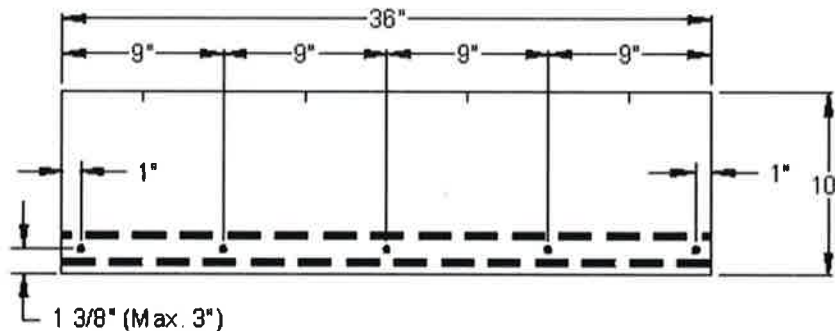

6.5 PRESIDENTIAL STARTER AND PRESIDENTIAL STARTER IR:

6.5.1 General: These shingles shall be applied by using two (2) overlapping layers. Begin application of the bottom/lower layer of starter shingles by cutting and applying a 13-3/4" x 20" piece at the lower left rake/eaves corner overhanging rakes and eaves 1/4" to 3/4". Continue along the eaves with full-size 13-1/4" x 40" starter shingles. Each top/upper starter course shingle shall have its 2" top section removed at the perforations, resulting in 11-1/4" x 40" shingles. The colored granule portion of the "top" starter shingles shall be located nearest the lowermost eave edge. Install the first top/upper starter shingle so that it is flush to the left side and bottom edges of the first bottom/lower starter shingle. This first top/upper starter shingle shall be 11-1/4" x 38". Continue along the eaves with 11-1/4" x 40" top/upper starter shingles ensuring that the lower edges are flush with the lower edges of the bottom/lower layer. Reference the product's wrapper for more specific details.

Eaves: Fasten as shown below. Rakes: After applying the starter shingles at the eaves, but prior to installing the field shingles, starter shingles may be applied up the slope at the rake edge. Fasten as shown below.

Fastening: Four nails are required per shingle. Nails shall be of sufficient length to penetrate into the deck 3/4" or through the thickness of the decking, whichever is less. Nails are to be 11 or 12 gauge, corrosion-resistant roofing nails with 3/8" heads.

Presidential Starter and Presidential IR Starter Shingles

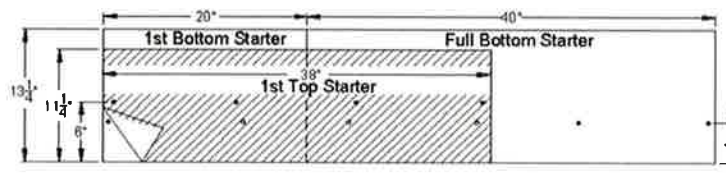

6.6 UNIVERSAL STARTER:

6.6.1 General: While Universal Starter Strip shingles are specifically designed to be used with shingles 36" length and having a weather exposure of $\leq 5"$, they may be installed beneath shingles of any length if special precautions are taken. **IMPORTANT:** In all cases the end joints of the starter and the first course shingles shall NEVER BE LESS THAN 3-1/2" apart.

Eaves: The sealant on starter courses should face out and lie as close as possible to the eaves edge of the roof. Fasten as described below. Rakes: After applying the starter shingles at the eaves, but prior to installing the field shingles, starter shingles may be applied up the slope at the rake edge with sealant facing out and nearest to the outer roof edge. Fasten as described below.

Fastening: Use four nails on these starter shingles as shown below. The sealant on starter courses shall lie as close as possible to the eaves edge of the roof. Nails shall be of sufficient length to penetrate into the deck 3/4" or through the thickness of the decking, whichever is less. Nails are to be 11 or 12 gauge, corrosion-resistant roofing nails with 3/8" heads.

UNIVERSAL STARTER SHINGLES

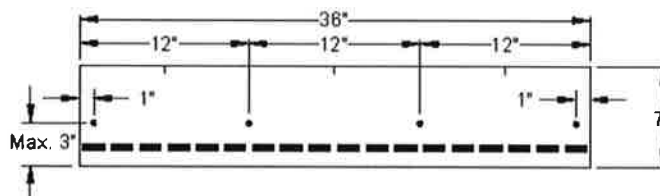

6.7 SWIFTSTART® STARTER SHINGLE:

Fastening: Use four nails, located as shown below

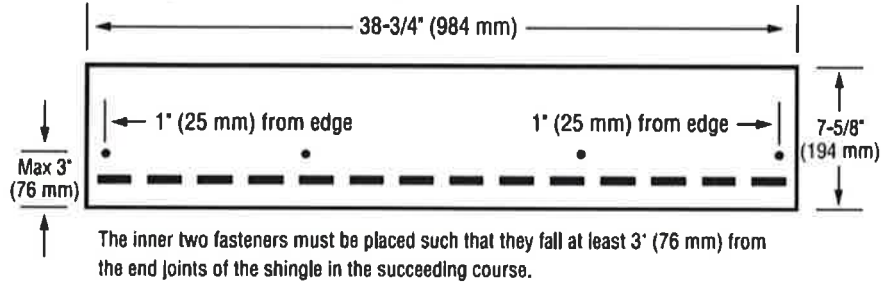

6.8 CT20™, XT™ 25, XT™ 30, XT™ 30 IR:

LOW AND STANDARD SLOPE

ENGLISH

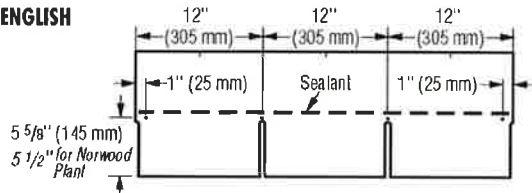

METRIC

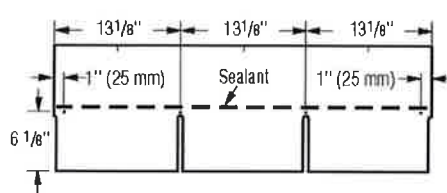

Figure 11-3: Use **four nails** for every full shingle.

STEEP SLOPE

Use **four nails** and six spots of asphalt roofing cement* for every full shingle (Figure 11-4). Asphalt roofing cement meeting ASTM D4586 Type II is suggested.

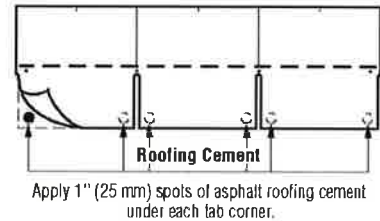

Figure 11-4: Use **four nails** and **six spots of asphalt cement** on steep slopes.

***CAUTION:** Excessive use of roofing cement can cause shingles to blister.

6.8.1 Hip & Ridge for CT20™, XT™ 25, XT™ 30, XT™ 30 IR: Cut Shingles

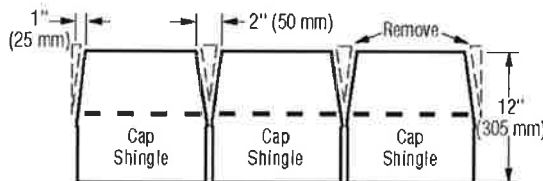

Figure 11-24: Cut tabs, then trim back to make cap shingles (English dimensions shown).

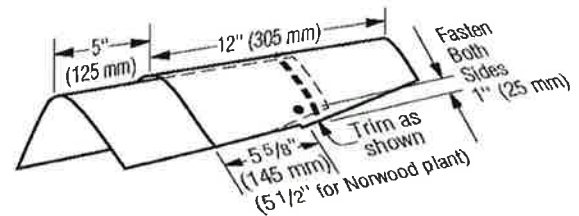

Figure 11-25: Installation of caps along the hips and ridges.

6.8.1.1 For ASTM D3161, Class F performance use BASF "Sonolastic® NP1™" adhesive or Henkel "PL® Polyurethane Roof & Flashing Sealant", in accordance with CertainTeed requirements.

6.9 ARCADIA™:

LOW AND STANDARD SLOPE

Use SIX nails for every full shingle located as shown below.

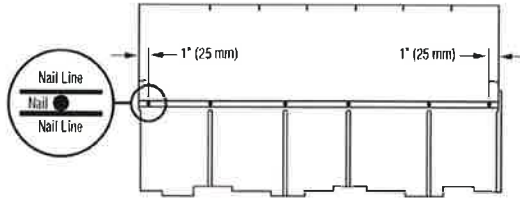

Figure 2: Use six nails for every full shingle.

STEEP SLOPE

Use SIX nails and FOUR spots of asphalt roofing cement for every full shingle as shown below. Apply asphalt roofing cement 1" (25 mm) from edge of shingle. Asphalt roofing cement meeting ASTM D 4586 Type II is suggested.

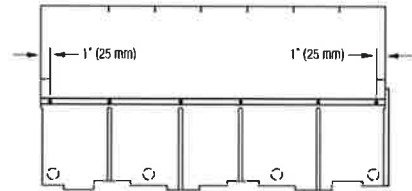
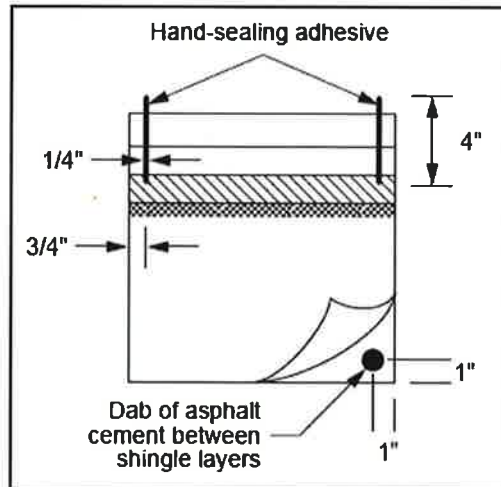
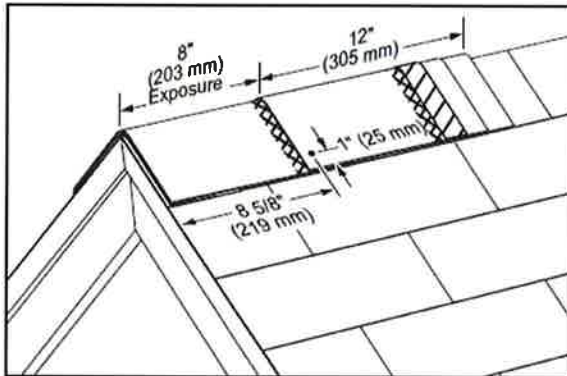

Figure 3: Use six nails and four spots of asphalt roofing cement on steep slopes.

6.9.1 Hip & Ridge for Arcadia™: Cedar Crest™, Cedar Crest™ IR

Use two (2), minimum 1¾-inch long fasteners per shingle. For the starter shingle, place fastener 1-inch from each side edge and about 2-inch up from the starter shingle's exposed butt edge, ensuring minimum ¾-inch embedment into the deck, or full penetration through the deck. For each full Cedar Crest shingle, place fasteners 8-5/8-inch up from its exposed butt edge and 1-inch from each side edge.

For ASTM D3161, Class F performance use BASF "Sonolastic® NP1™" adhesive or Henkel "PL® Polyurethane Roof & Flashing Sealant", in accordance with CertainTeed requirements, to hand-seal Cedar Crest shingles. Apply NP 1 or PL adhesive from the middle of the shingle's raised overlay on the top piece and extending approximately 4-inch along the sides of the headlap along a line ¾ to 1-inch from each side of the shingle's headlap. Immediately align and apply the overlying shingle, gently pressing tab sides into the adhesive, and install nails. To secure the other side, apply a 1-inch diameter spot of NP 1 or PL adhesive between the shingle layers.



6.10 BELMONT® OR BELMONT® IR:

Low and Standard Slope

(2:12 to 21:12):

Use FIVE nails for every full Belmont shingle, located as shown below.

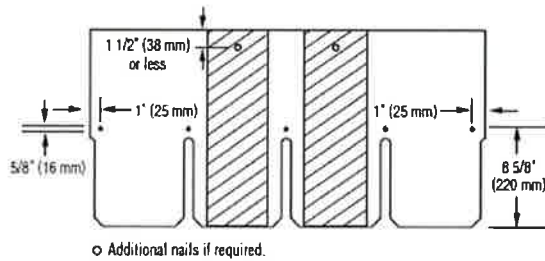

Steep Slope (greater than 21:12):

Use SEVEN nails and EIGHT spots of asphalt roofing cement** for every full Belmont shingle. Apply asphalt roofing cement 1" (25mm) from edge of shingle.

See below. Asphalt roofing cement meeting ASTM D4586 Type II is suggested.

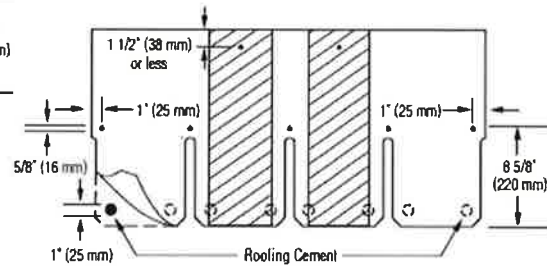

6.10.1 Hip & Ridge for Belmont® or Belmont® IR:

6.10.1.1 Option 1: For Belmont®, refer to instructions herein for Cedar Crest™ or Cedar Crest™ IR hip and ridge shingles. For Belmont® IR, refer to instructions herein for Cedar Crest™ IR hip and ridge shingles.

6.10.1.2 Option 2: For Belmont®: Shangle® Ridge

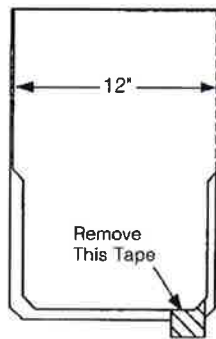

Figure 17-18: Shangle® Ridge.

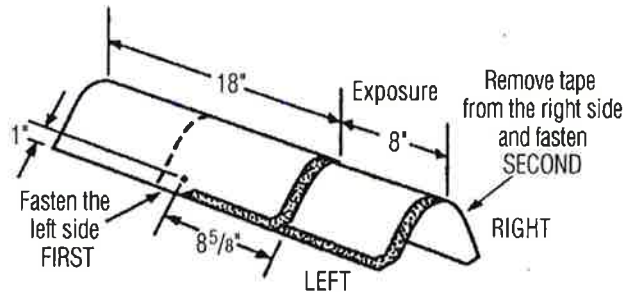

Figure 17-19: Installation of Shangle® Ridge shingles on hips and ridges.

6.10.1.3 For ASTM D3161, Class F performance use BASF "Sonolastic® NP1™" adhesive or Henkel "PL® Polyurethane Roof & Flashing Sealant", in accordance with CertainTeed requirements.

6.11 CARRIAGE HOUSE SHANGLE® AND GRAND MANOR SHANGLE®:

LOW AND STANDARD SLOPE

Use five nails for every full Shangle.

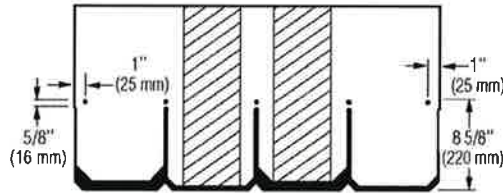

Figure 17-4: Use five nails for every full Grand Manor Shangle, Carriage House Shangle, or Centennial Slate.

STEEP SLOPE

Use seven nails and three spots of asphalt roofing cement for every full Grand Manor Shangle. Use five nails and three spots of asphalt roofing cement for every full Carriage House Shangle and Centennial Slate. Apply asphalt roofing cement 1" (25 mm) from edge of shingle (Figure 17-5). Asphalt roofing cement meeting ASTM D4586 Type II is suggested.

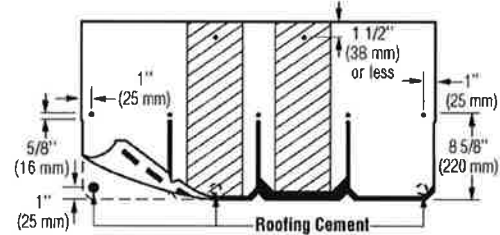
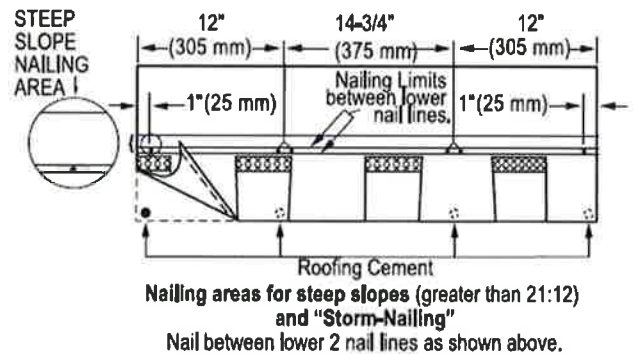
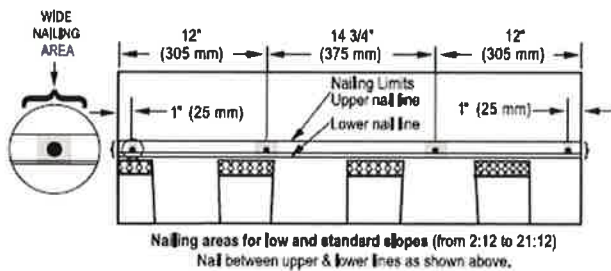

Figure 17-5: When installing Grand Manor Shangles on steep slopes, use seven nails and three spots of asphalt roofing cement.

6.11.1 **Hip & Ridge for Carriage House Shangle® and Grand Manor Shangle:** Refer to instructions herein for **Shangle® Ridge** hip and ridge shingles

6.12 LANDMARK™, LANDMARK™ IR, LANDMARK™ PRO, LANDMARK™ PRO SOLARIS, LANDMARK™ PREMIUM, LANDMARK™ SOLARIS, LANDMARK™ SOLARIS IR, LANDMARK™ SOLARIS GOLD/PLATINUM OR NORTHGATE:



6.12.1 **Hip & Ridge for Landmark™, Landmark™ IR, Landmark™ Pro, Landmark™ Pro Solaris, Landmark™ Premium, Landmark™ Solaris, Landmark™ Solaris IR, Landmark™ Solaris Gold/Platinum or NorthGate:**

6.12.1.1 **Option 1: Shadow Ridge™ or NothGate Accessory**

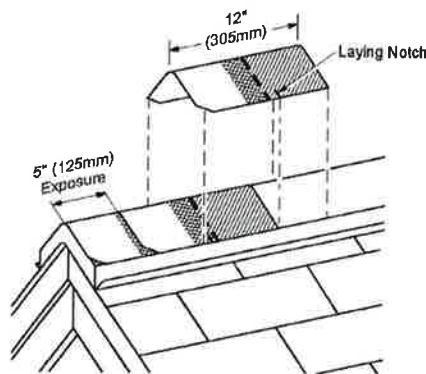
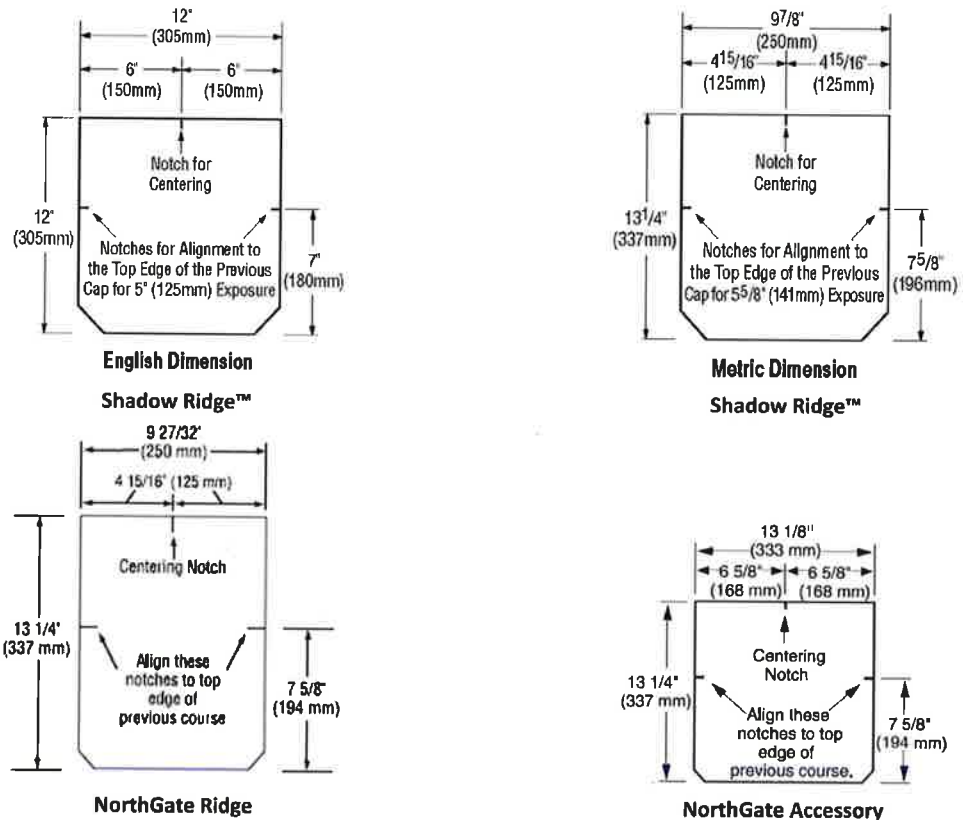

Figure 13-20: Use laying notches to center shingles on hips and ridges, and to locate the correct exposure.

6.12.1.2 Optional for Shadow Ridge™ *produced in Oxford, NC*: For ASTM D3161, Class F performance use BASF "Sonolastic® NP1™" adhesive or Henkel "PL® Polyurethane Roof & Flashing Sealant", in accordance with CertainTeed requirements.

6.12.1.3 **Option 2:** Refer to instructions herein for Cedar Crest™, Cedar Crest™ IR hip and ridge shingles.

6.13 LANDMARK™ TL:

LANDMARK TL

LANDMARK TL

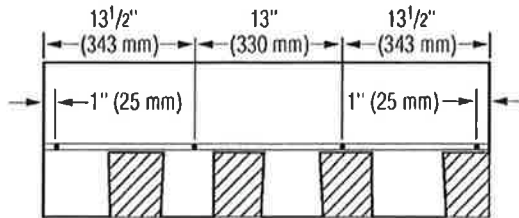

Figure 13-4: Use four nails for every full shingle.

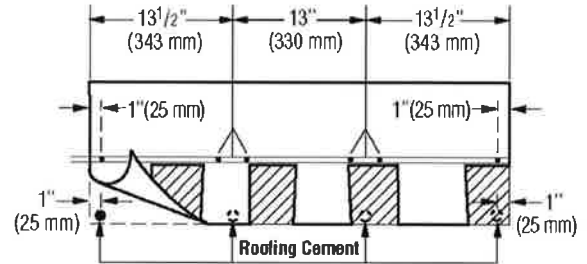

Figure 13-5: Use six nails and four spots of asphalt roofing cement on steep slopes.

6.13.1 Hip & Ridge for Landmark™ TL: Refer to Option 1 or 2 for Landmark™.

6.14 PRESIDENTIAL SHAKE™, PRESIDENTIAL SHAKE™ IR, PRESIDENTIAL SHAKE TL™, PRESIDENTIAL SOLARIS™:

LOW AND STANDARD SLOPE:

For low and standard slopes, use five nails for each full Presidential shingle as shown below.

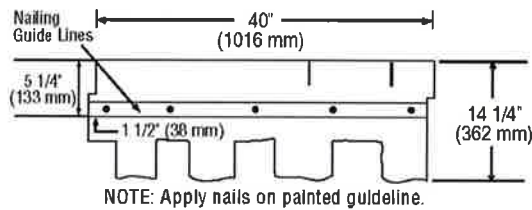

Figure 16-6: Fastening Presidential and Presidential TL Shake shingles on low and standard slopes.

STEEP SLOPE:

For steep slopes, use nine nails for each full Presidential shingle and apply 1" diameter spots of asphalt roofing cement under each shingle tab. After applying 5 nails in between the nailing guide lines, apply 4 nails 1" above tab cutouts making certain tabs of overlying shingle cover nails.

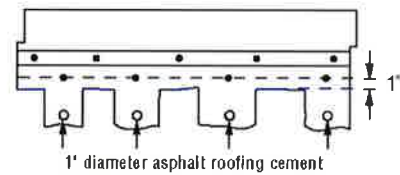

Figure 16-7: Fastening Presidential and Presidential TL Shake shingles on steep slopes.

6.14.1 Hip & Ridge for Presidential Shake™, Presidential Shake™ IR, Presidential Shake TL™, Presidential Solaris™:

6.14.1.1 Option 1: Presidential Accessory

PRESIDENTIAL ACCESSORY

Presidential accessory shingles can be used for covering hips and ridges. Apply shingles up to the ridge (expose no more than 7" from the bottom edge of the "tooth." Fasten each accessory with two fasteners. The fasteners must be 1 3/4" long or longer, so they penetrate either 3/4" into the deck or completely through the deck. Presidential accessory comes in two different sizes: Accessory produced in Birmingham, AL is 12" x 12"; Portland, OR produces 9 7/8" x 13 1/4" accessory.

6.14.1.2 For ASTM D3161, Class F performance use BASF "Sonolastic® NP1™" adhesive or Henkel "PL® Polyurethane Roof & Flashing Sealant", in accordance with CertainTeed requirements.

6.14.1.3 Option 2: Refer to instructions herein for Cedar Crest™, Cedar Crest™ IR hip and ridge shingles.

6.15 HATTERAS™:

LOW, STANDARD AND STEEP SLOPE:

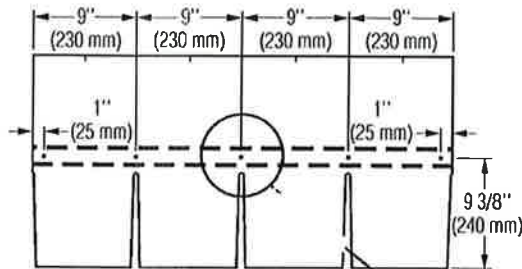

Figure 15-3: Fastening Hatteras Shingles on Low and Standard Slopes

For low and standard slopes, use five nails for each full Hatteras shingle as shown above.

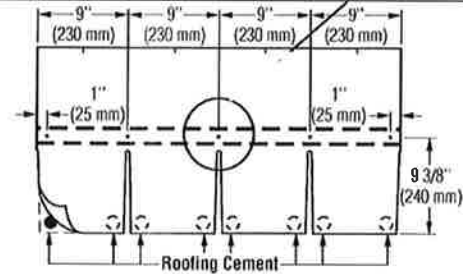

Figure 15-4: Fastening Hatteras Shingles on Steep Slopes

For steep slopes, use five nails and eight spots of asphalt roofing cement for each full Hatteras shingle as shown above. Apply 1" (25mm) diameter spots of roofing cement (ASTM D 4586 Type II suggested) under each tab corner. Press shingle into place; do not expose cement.

CAUTION: Too much roofing cement can cause shingles to blister.

6.15.1 Hip & Ridge for Hatteras™:

6.15.1.1 Option 1: Accessory for Hatteras

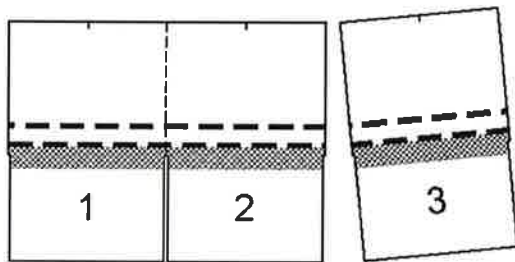
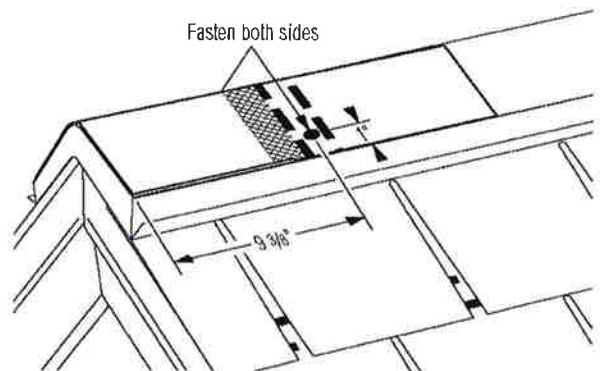

Figure 15-14: 18 three-piece units separate to make 54 Hatteras Accessory shingles.



6.15.1.2 Option 2: Cut Hatteras Shingles

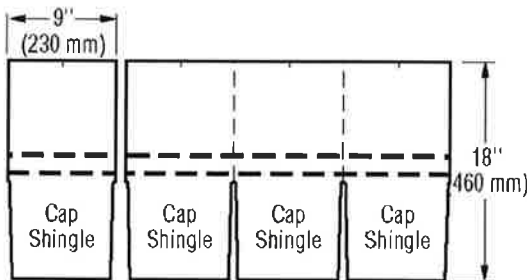

Figure 15-20: Cut Hatteras shingles to make cover cap.

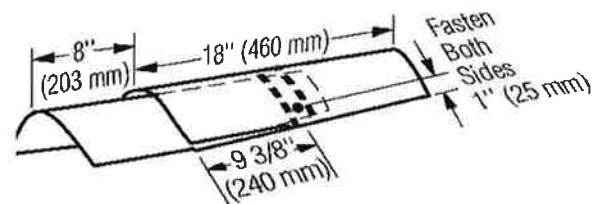

Figure 15-21: Installation of caps along hips and ridges.

6.15.1.3 For ASTM D3161, Class F performance use BASF "Sonolastic® NP1™" adhesive or Henkel "PL® Polyurethane Roof & Flashing Sealant", in accordance with CertainTeed requirements.

6.16 HIGHLAND SLATE™, HIGHLAND SLATE™ IR:

LOW AND STANDARD SLOPE:

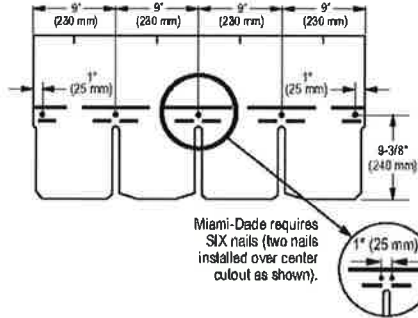

Figure 11-3: Use FIVE nails for every Highland Slate shingle.

STEEP SLOPE:

Use FIVE nails and EIGHT spots of asphalt roofing cement* for each full Highland Slate shingle. For Miami-Dade, SIX nails are required. Apply 1" diameter spots of asphalt roofing cement under each tab corner. Asphalt roofing cement meeting ASTM D4586 Type II is suggested.

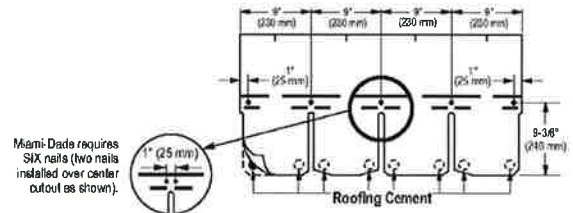

Figure 11-3A: Use FIVE nails and eight spots of asphalt roofing cement under each tab corner.

*CAUTION: Excessive use of roofing cement can cause shingles to blister.

6.16.1 **Hip & Ridge for Highland Slate™, Highland Slate™ IR:** Refer to instructions herein for Cedar Crest™, Cedar Crest™ IR or Shangle Ridge™ hip and ridge shingles.

6.17 PATRIOT™:

LOW AND STANDARD SLOPE

Use FOUR nails for every full shingle located as shown below.

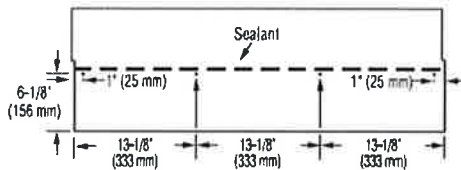

6.17.1 **Hip & Ridge for Patriot™:** Refer to instructions herein for Cedar Crest™, Cedar Crest™ IR, Shadow Ridge™, NorthGate or Shangle Ridge™ hip and ridge shingles.

STEEP SLOPE

Use FOUR nails and four spots of asphalt roofing cement for every full shingle as shown below. Asphalt roofing cement meeting ASTM D4586 Type II is suggested. Apply 1" (25 mm) spots of asphalt roofing cement as shown.

CAUTION: Excessive use of roofing cement can cause shingles to blister.

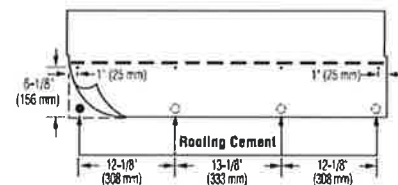



NEMO|etc.

7. LABELING:

- 7.1 Each unit shall bear a permanent label with the manufacturer's name, logo, city, state and logo of the Accredited Quality Assurance Agency noted herein.
- 7.2 Asphalt shingle wrappers shall indicate compliance with one of the required classifications detailed in **FBC Table 1507.2.7.1 / R905.2.6.1.**

8. BUILDING PERMIT REQUIREMENTS:

As required by the Building Official or Authority Having Jurisdiction to properly evaluate the installation of this product.

9. MANUFACTURING PLANTS:

Contact the named QA entity for information on which plants produce products covered by **Florida Rule 61G20-3** QA requirements.

10. QUALITY ASSURANCE ENTITY:

UL LLC – QUA9625; (414) 248-6409; karen.buchmann@us.ul.com

- END OF EVALUATION REPORT -

FLORIDA DEPARTMENT OF
Business & Professional Regulation



[BCIS Home](#) | [Log In](#) | [User Registration](#) | [Hot Topics](#) | [Submit Surcharge](#) | [Stats & Facts](#) | [Publications](#) | [Contact Us](#) | [BCIS Site Map](#) | [Links](#) | [Search](#)



Product Approval
USER: Public User

[Product Approval Menu](#) > [Product or Application Search](#) > [Application List](#) > **Application Detail**

OFFICE OF THE
SECRETARY

FL #	FL21841-R5
Application Type	Revision
Code Version	2017
Application Status	Approved
Comments	
Archived	<input type="checkbox"/>
Product Manufacturer	CertainTeed Corporation-Roofing
Address/Phone/Email	20 Moores Road Malvern, PA 19355 (610) 893-5400 mark.d.harner@saint-gobain.com
Authorized Signature	Mark Harner mark.d.harner@saint-gobain.com
Technical Representative	Mark D. Harner
Address/Phone/Email	18 Moores Road Malvern, PA 19355 (610) 651-5847 Mark.D.Harner@saint-gobain.com
Quality Assurance Representative	
Address/Phone/Email	
Category	Roofing
Subcategory	Underlayments
Compliance Method	Evaluation Report from a Florida Registered Architect or a Licensed Florida Professional Engineer <input type="checkbox"/> Evaluation Report - Hardcopy Received
Florida Engineer or Architect Name who developed the Evaluation Report	Robert Nieminen
Florida License	PE-59166
Quality Assurance Entity	QAI Laboratories
Quality Assurance Contract Expiration Date	06/12/2020
Validated By	John W. Knezevich, PE <input checked="" type="checkbox"/> Validation Checklist - Hardcopy Received
Certificate of Independence	FL21841_R5_COI_2019_01_COI_NIEMINEN.pdf
Referenced Standard and Year (of Standard)	Standard ASTM D1970 (tear) ASTM D226 (physicals)
	Year 2015 2009
Equivalence of Product Standards Certified By	
Sections from the Code	



NEMO|etc.

Certificate of Authorization #32455
353 Christian Street, Unit #13
Oxford, CT 06478
(203) 262-9245

ENGINEER

EVALUATE

TEST

CONSULT

CERTIFY

EVALUATION REPORT

CertainTeed Corporation

20 Moores Road
Malvern, PA 19355
(610) 651-5847

Evaluation Report 13500.02.17-R4

FL21841-R4

Date of Issuance: 02/10/2017

Revision 4: 06/14/2018

SCOPE:

This Evaluation Report is issued under **Rule 61G20-3** and the applicable rules and regulations governing the use of construction materials in the State of Florida. The documentation submitted has been reviewed by Robert Nieminen, P.E. for use of the product under the Florida Building Code and Florida Building Code, Residential Volume. The products described herein have been evaluated for compliance with the **6th Edition (2017) Florida Building Code** sections noted herein.

DESCRIPTION: RoofRunner™ High Performance Synthetic Roofing Underlayment and DiamondDeck® High Performance Synthetic Underlayment

LABELING: Labeling shall be in accordance with the requirements of the Accredited Quality Assurance Agency noted herein.

CONTINUED COMPLIANCE: This Evaluation Report is valid until such time as the named product(s) changes, the referenced Quality Assurance documentation changes, or provisions of the Code that relate to the product change. Acceptance of this Evaluation Report by the named client constitutes agreement to notify Robert Nieminen, P.E. of any changes to the product(s), the Quality Assurance or the production facility location(s). NEMO|etc. requires a complete review of this Evaluation Report relative to updated Code requirements with each Code Cycle.

ADVERTISEMENT: The Evaluation Report number preceded by the words "NEMO|etc. Evaluated" may be displayed in advertising literature. If any portion of the Evaluation Report is displayed, then it shall be done in its entirety.

INSPECTION: Upon request, a copy of this entire Evaluation Report shall be provided to the user by the manufacturer or its distributors and shall be available for inspection at the job site at the request of the Building Official.

This Evaluation Report consists of pages 1 through 4.

Prepared by:

Robert J.M. Nieminen, P.E.

Florida Registration No. 59166, Florida DCA ANE1983



The facsimile seal appearing was authorized by Robert Nieminen, P.E. on 06/14/2018. This does not serve as an electronically signed document.

CERTIFICATION OF INDEPENDENCE:

1. NEMO ETC, LLC does not have, nor does it intend to acquire, or will it acquire, a financial interest in any company manufacturing or distributing products it evaluates.
2. NEMO ETC, LLC is not owned, operated or controlled by any company manufacturing or distributing products it evaluates.
3. Robert Nieminen, P.E. does not have nor will acquire, a financial interest in any company manufacturing or distributing products for which the evaluation reports are being issued.
4. Robert Nieminen, P.E. does not have, nor will acquire, a financial interest in any other entity involved in the approval process of the product.
5. This is a building code evaluation. Neither NEMO|etc. nor Robert Nieminen, P.E. are, in any way, the Designer of Record for any project on which this Evaluation Report, or previous versions thereof, is/was used for permitting or design guidance unless retained specifically for that purpose.

ROOFING COMPONENT EVALUATION:

1. SCOPE:

Product Category: Roofing
Sub-Category: Underlayment
Compliance Statement: RoofRunner™ High Performance Synthetic Roofing Underlayment and DiamondDeck® High Performance Synthetic Underlayment, as produced by CertainTeed Corporation in Dadara, India, have demonstrated compliance with the following sections of the 6th Edition (2017) Florida Building Code through testing in accordance with applicable sections of the following Standards. Compliance is subject to the Installation Requirements and Limitations / Conditions of Use set forth herein.

2. STANDARDS:

Section	Properties	Standard	Year
1507.1.1, R905.1.1 Exception	Unrolling, Breaking Strength, Pliability	ASTM D226	2009
1507.1.1, R905.1.1 Exception	Tear strength	ASTM D1970	2015

3. REFERENCES:

Entity	Examination	Reference	Date
ERD (TST6049)	Physical Properties, D226	ACT-SC14110.06.17-3	06/29/2017
ERD (TST6049)	Tear strength	CTR-SC16080.17	07/31/2017
ERD (TST6049)	Tear strength	ACT-SC16550.17	10/19/2017
QAI (TST9808)	Physical Properties, AC188	RJ3502P-1	11/05/2014
QAI (TST9808)	Physical Properties, AC188	RJ3502P-2	11/05/2014
QAI (QUA7628)	Traceability/Inspections	Service Confirmation	06/12/2018

4. PRODUCT DESCRIPTION:

- 4.1 **RoofRunner™** is a synthetic polymer-based scrim-reinforced underlayment designed for use on roof decks as a water-resistant layer beneath asphalt roofing shingles; meets FBC 1507.1.1 & R905.1.1 (Exception). **RoofRunner™** consists of a woven polyolefin base with a layer of nonwoven polyolefin sheet and a polymer coating on the back side. **RoofRunner™** is available in rolls 48-inch x 250-ft; nominal unit weight of 2.25 lbs/square.
- 4.2 **DiamondDeck®** is a synthetic polymer-based scrim-reinforced underlayment designed for use on roof decks as a water-resistant layer beneath prepared roof coverings; meets FBC 1507.1.1 (Exception). **DiamondDeck®** consists of a woven polyolefin base with a layer of nonwoven polyolefin sheet and a polymer coating on the back side, is available in rolls 48-inch x 250-ft and has a nominal unit weight of 3.80 lbs/square.

5. LIMITATIONS:

- 5.1 This is a building code evaluation. Neither NEMO ETC, LLC nor Robert Nieminen, P.E. are, in any way, the Designer of Record for any project on which this Evaluation Report, or previous versions thereof, is/was used for permitting or design guidance unless retained specifically for that purpose.
- 5.2 This Evaluation Report is not for use in FBC HVHZ jurisdictions.
- 5.3 Fire Classification is not part of this Evaluation Report; refer to current Approved Roofing Materials Directory or test report from accredited testing/listing agency for fire ratings of this product.
- 5.4 **RoofRunner™** or **DiamondDeck®** may be used with any prepared roof cover where the product is specifically referenced within FBC approval documents. If not listed, a request may be made to the Authority Having Jurisdiction for approval based on this evaluation combined with supporting data for the prepared roof covering.
- 5.5 **RoofRunner™** or **DiamondDeck®** shall not be installed on roof slopes below 2:12.

5.6 Allowable roof covers:

Table 1: Roof Cover Options					
Underlayment	Asphalt Shingles	Tile	Metal	Wood Shakes & Shingles	Slate
RoofRunner™	Yes	No	No	No	No
DiamondDeck®	Yes	No	Yes	Yes	Yes

5.7 Exposure Limitations:

For **RoofRunner™**, CertainTeed recommends primary roofing be installed within 48 hours of underlayment installation for re-roof applications or within 10-days of underlayment installation for new construction applications. **DiamondDeck®**, produced in Dadra, India, shall not be left exposed for longer than 30-days after installation.

6. INSTALLATION:

- 6.1 **RoofRunner™** or **DiamondDeck®** shall be installed in accordance with **CertainTeed Corporation** published installation instructions subject to the Limitations set forth in Section 5 herein and the specifics noted below.
- 6.2 Shall be installed in compliance with the requirements for **ASTM D226, Type I or II** underlayment in **FBC Table 1507.1.1 or R905.1.1** for the type of prepared roof covering to be installed, considering the wider sheet-width for double-layer applications.
- 6.3 Re-fasten any loose decking panels, and check for protruding nail heads. Sweep the substrate thoroughly to remove any dust and debris prior to application.
- 6.4 Consult **CertainTeed** published recommendations for the installation of a leak barrier of ASTM D1970, such as **CertainTeed Winter Guard (FL11288)**, or equal holding Florida Statewide Product Approval at vulnerable leak areas.
- 6.5 Single Layer; Roof Slope > 4:12:
For slopes 4:12 (18.4°) or greater: **RoofRunner™** or **DiamondDeck®** shall be laid horizontally, parallel to the eave with the printed side up, flat and unwrinkled and have minimum 3-inch side (horizontal) laps and minimum 6-inch end (vertical) laps. Side (horizontal) laps shall run with the flow of water in a shingling manner. End (vertical) laps shall be offset from course to course not less than 3 feet.
- 6.6 Double Layer; 2:12 < Roof Slope < 4:12:
For slopes 2:12 (9.4°) to <4:12 (18.4°): **RoofRunner™** or **DiamondDeck®** shall be applied in a double coverage method, flat and unwrinkled. Begin by applying a 25.5-inch wide starter-strip of **RoofRunner™** or **DiamondDeck®** along the eaves. Then place a full-width sheet over the starter, with the lower edge flush to the starter's lower edge. Apply succeeding 48-inch wide courses up the roof slope, overlapping each previous course a minimum of 25.5-inches in a "shingle fashion" with minimum 12-inch end (vertical) laps. End (vertical) laps shall be offset from course to course not less than 3 feet.
- 6.7 Where laps or joints require sealant or adhesive, use high quality asphalt roofing cement meeting ASTM D4586, Type II or cements/caulks based on butyl rubber or urethane. CertainTeed recommends sealing all laps and joints where the underlayment will be exposed to wind-driven rain.

6.8 Attachment:

Code Reference: The Exception statement in FBC 1507.1.1 and FBC R905.1.1 requires use of metal cap nails where the ultimate design wind speed, V_{ult} , equals or exceeds 150 mph.

Minimum fasteners shall be corrosion resistant plastic cap nails with minimum 1-inch diameter head. **Do not use staples.** Ensure fasteners are installed at 90 degree angle to the deck with flush contact between the plastic cap or metal cap and the upper surface of the underlayment. Fasteners shall be of sufficient length to penetrate through the underside of plywood or OSB decks, or minimum 3/4-inch embedment into dimensional lumber / tongue-and-groove wood decks.

Short-term exposure (< 2 days):

When the finished roofing will be installed within two days of underlayment application and high winds are not forecast, corrosion-resistant or stainless steel roofing nails with 3/8-inch diameter heads may be used. Attach the underlayment by nailing a fastener through each diamond printed on the underlayment and tight to the surface. Proper fastener spacing is 15-inch o.c. vertically and 12-inch o.c. horizontally (parallel to eaves). On vertical side/end laps install 8 fasteners equally spaced at 6-inch o.c. centered in the lap to hold the underlayment in place. If wind or rain is expected prior to finish roofing application, use 1-inch diameter plastic or steel cap nails, as below.

Long-term exposure (> 2 days to max. 10-days for RoofRunner™ or > 2 days to max. 30-days for DiamondDeck®):

When anticipated exposure time may exceed two days, use low-profile plastic or steel cap nails with 1-inch diameter heads to fasten in place. Attach the underlayment by nailing a fastener through each diamond printed on the underlayment and tight to the surface, as described above.

6.9 RoofRunner™ or DiamondDeck® may not be used in any exposed application, including but not limited to crickets, exposed valleys or exposed roof to wall details.

7. BUILDING PERMIT REQUIREMENTS:

As required by the Building Official or Authority Having Jurisdiction in order to properly evaluate the installation of this product.

8. MANUFACTURING PLANTS:

Contact the noted QA agency for information on product locations covered for F.A.C. 61G20-3 QA requirements. The following plants have qualified products under their respective physical properties specifications.

Plant	Specification	Product(s)
Dadra, India	FBC 1507.1.1 (Exception)	RoofRunner™ and DiamondDeck®

9. QUALITY ASSURANCE ENTITY:

Quality Auditing Institute, Ltd. – QUA7628; (604) 527-8378, mlansdowne@qai.org

- END OF EVALUATION REPORT -