



City of Belle Isle Job Site Card WINDOW/DOOR PERMIT 2020-04-039

Subdivision

Site Address: 2844 Montmart Dr 32812

Class: Residential

Parcel Number: 18-23-30-4391-04-380

=====
Description of Work: 1 Door (s) / Size for Size
=====

=====
Issued: Lowe's Home Centers LLC; Peter Cafaro License # CGC158417
Contact # 407 468-1010 **Payment/ Issued Date & Method:** 4/16/2020

Picked up by _____ Emailed
 Visa Master Card Amex Discover Check / Money Order#
0 7 3 3

BUILDING INSPECTOR DATE COMMENTS

900 In Progress			
905 Window/Door Buck			
910 Final			

PLEASE NOTE

In order to schedule any inspections, the **PERMIT / plans-specs.** must be issued and **POSTED** on the **JOB SITE!**

THIS WILL AVOID ANY FAILED INSPECTIONS & RE-INSPECTION FEES. A permit **expires** in 6 months if approved inspections are not recorded /scheduled within that time frame. You are responsible for scheduling and keeping track all of your inspections –

☆ **Inspection requests are to be emailed to IDScheduling@UniversalEngineering.com; a confirmation email will be sent back to you upon scheduling. Next-Day Inspection requests must be made by 3:00 p.m.**

Please include the following requirements in your request:

- **Project Address**
- **Corresponding Permit Number**
- **Type of Inspection** (Please reference your permit card for inspection codes)
- **Date of Inspection** (If no date is specified, the inspection will be scheduled for the next business day)
- **Contact Name**
- **Contact Phone Number**
- **Gate / Entry code** (If applicable)
- **AM, PM, or Any Time** (We do our best to accommodate time requests but cannot guarantee an exact arrival)

Universal Engineering Sciences - 3532 Maggie Blvd., Orlando, FL 32811407-581-8161
Fax 407-581-0313 www.universalengineering.com

"WARNING TO OWNER: YOUR FAILURE TO RECORD A NOTICE OF COMMENCEMENT MAY RESULT IN YOUR PAYING TWICE FOR IMPROVEMENTS TO YOUR PROPERTY. IF YOU INTEND TO OBTAIN FINANCING, CONSULT WITH YOUR LENDER OR AN ATTORNEY BEFORE RECORDING YOUR NOTICE OF COMMENCEMENT."



City of Belle Isle
Universal Engineering Sciences 3532 Maggie Blvd., Orlando, FL 32811
Tel 407-581-8161 * Fax 407-581-0313 * www.universalengineering.com

APPLICATION FOR SIZE-FOR-SIZE WINDOW / DOOR PERMIT

WARNING TO OWNER: YOUR FAILURE TO RECORD A NOTICE OF COMMENCEMENT MAY RESULT IN YOUR PAYING TWICE FOR IMPROVEMENTS TO YOUR PROPERTY. A NOTICE OF COMMENCEMENT MUST BE RECORDED AND POSTED ON THE JOB SITE BEFORE THE FIRST INSPECTION. IF YOU INTEND TO OBTAIN FINANCING, CONSULT WITH YOUR LENDER OR AN ATTORNEY BEFORE RECORDING YOUR NOTICE OF COMMENCEMENT.

DATE OF APPLICATION: 3/26/20

PERMIT NUMBER 2020-04-039

PLEASE PRINT. The undersigned hereby applies for a permit to make installations as indicated below:

Project Address 2844 MONTMART DR, Belle Isle, FL 32809 32812

Property Owner TAHRA WEST Phone 407-227-9953

Property Owner's Mailing Address 2844 MONTMART DR City BELLE ISLE

State FL Zip Code 32812 Parcel Id Number: 18-23-30-4391-04-380

REQUIRED! To obtain this information, please visit <http://www.ocpafl.org/Searches/ParcelSearch.aspx>

Type of Building: Residential Commercial Other

REQUIRED! Florida Product Approval Form - NOTE: installation instructions must be posted on-site before your first inspection!!
Handwritten: KISA 0733, 7-16-2020

Please indicate the nature of work by completing the information below:

Number of Size-for-Size Windows: 0 Number of Size-for-Size Doors: 1 Job Valuation: 4485

I hereby certify that the above is true and correct to the best of my knowledge and make Application for Permit as outlined above, and if same is granted I agree to conform to all Florida Building Code Regulations and City Ordinances regulating same and in accordance with plans submitted. The issuance of this permit does not grant permission to violate any applicable Town and/or State of Florida codes and/or ordinances. By signing below, I recognize Republic Services is by legal contract the sole authorized provider of garbage, recycling, yard waste, and commercial garbage and construction debris collection and disposal services with the city limits of the City. Contractors, homeowners and commercial businesses may contact Republic Services at 407-293-8600 to setup accounts for Commercial, Construction Roll Off, or other services needed. Rates are fixed by contract and are available at City Hall or from Republic Services. The City enforces the contract through its code enforcement office. Failure to comply will result in a stop work order.

BY SIGNING THIS APPLICATION, YOU ARE CERTIFYING THAT YOU ARE ACTING AS THE OWNER'S AGENT FOR THIS PERMIT:

LICENSE HOLDER SIGNATURE _____ LICENSE # CGC1508417

LICENSE HOLDER NAME PETER A CAFARO III COMPANY NAME LOWES HOME CENTERS LLC

Street Address PO BOX 781993

City ORLANDO State FL Zip Code 32878 Phone Number 352-300-3360

Email Address PERMITSPLUSLLC@GMAIL.COM

Handwritten: COMPLETED, w/c EXPIRED

Building Official: OTC Date 4-15-20
Verified Contractor's Licenses & Insurance are on file SM Date 4-15-20

Handwritten calculations:
1511K
4x4
25
16
41.50
20.50
61.50
NOCV

Zoning Fee	\$	<u>0</u>
Permit Fee	\$	<u>41.50</u>
Review Fee	\$	<u>20.50</u>
1% BCA/B Fee	\$	<u>2 min</u>
1.5% DCA Fee	\$	<u>2 min</u>
Total Permit Fee	\$	<u>65.50</u>

Permit Number: 2020-04-039
 Folio/Parcel ID # 19-23-30-43A1-04-380
 Prepared by: Permits Plus - Megan E
131 SW 70th St U
OCOLA FL 34476
 Return to: Same as Above

DOC # 20200219375
 04/07/2020 08:54 AM Page 1 of 1
 Rec Fee: \$10.00
 Deed Doc Tax: \$0.00
 Mortgage Doc Tax: \$0.00
 Intangible Tax: \$0.00
 Phil Diamond, Comptroller
 Orange County, FL
 Ret To: SIMPLIFILE LC

NOTICE OF COMMENCEMENT

State of Florida, County of Orange

The undersigned hereby gives notice that improvement will be made to certain real property, and in accordance with Chapter 713, Florida Statutes, the following information is provided in this Notice of Commencement.

- Description of property** (legal description of the property, and street address if available)
Single Family Home Lake Conway Estates Sec Four Third Addition 1/43 lot 438 2844 Montmart Dr Belle Isle, FL
- General description of improvement**
Complete removal and replacement of single entry front door with two sidelights.
- Owner information or Lessee information if the Lessee contracted for the improvement**
 Name Tahra West & Floyd West Jr
 Address 2844 Mont Mart Drive Orlando, FL 32812 (Montmart Drive)
 Interest in Property OWNER
 Name and address of fee simple titleholder (if different from Owner listed above)
 Name N/A
 Address _____
- Contractor**
 Name Lowe's Home Centers LLC. Telephone Number 407.351.4667
 Address 2800 West Sand Lake Road Orlando, FL 32812
- Surety** (if applicable a copy of the payment bond is attached)
 Name N/A Telephone Number _____
 Address _____ Amount of Bond \$ _____
- Lender**
 Name N/A Telephone Number _____
 Address _____
- Persons within the State of Florida designated by Owner upon whom notices or other documents may be served as provided by §713.13(1)(a)7, Florida Statutes.**
 Name N/A Telephone Number _____
 Address _____
- In addition to himself or herself, Owner designates the following to receive a copy of the Lienor's Notice as provided in §713.13(1)(b), Florida Statutes.**
 Name N/A Telephone Number _____
 Address _____
- Expiration date of notice of commencement** (the expiration date will be 1 year from the date of recording unless a different date is specified)

WARNING TO OWNER: ANY PAYMENTS MADE BY THE OWNER AFTER THE EXPIRATION OF THE NOTICE OF COMMENCEMENT ARE CONSIDERED IMPROPER PAYMENTS UNDER CHAPTER 713, PART 1, SECTION 713.13, FLORIDA STATUTES, AND CAN RESULT IN YOUR PAYING TWICE FOR IMPROVEMENTS TO YOUR PROPERTY. A NOTICE OF COMMENCEMENT MUST BE RECORDED AND POSTED ON THE JOB SITE BEFORE THE FIRST INSPECTION. IF YOU INTEND TO OBTAIN FINANCING, CONSULT WITH YOUR LENDER OR AN ATTORNEY BEFORE COMMENCING WORK OR RECORDING YOUR NOTICE OF COMMENCEMENT.

Jahira Gilbert
 Signature of Owner or Lessee, or Owner's or Lessee's Authorized Officer/Director/Partner/Manager

 Signatory's Title/Office

The foregoing instrument was acknowledged before me this 18 day of Feb by Tahra West
 as owner for _____
 Type of authority, e.g., officer, trustee, attorney in fact Name of party on behalf of whom instrument was executed

Mera Ward
 Signature of Notary Public - State of Florida

Print, type, or stamp commissioned name of Notary Public

Personally Known _____ OR Produced ID X
 Type of ID Produced DL
Physical Presence

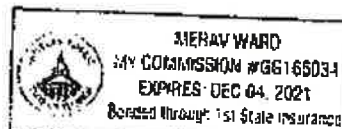



CITY OF BELLE ISLE, FLORIDA
 Universal Engineering Sciences 3532 Maggie Blvd., Orlando, FL 32811
 Tel 407-581-8161 * Fax 407-581-0313 * www.universaleengineering.com

POWER OF ATTORNEY

Date: 3/26/20

Permit #: 2020-04039

I hereby name and appoint MEGAN ROMANO & HAILIGH SCHWINGEL of
(print name)

LOWE'S HOME CENTERS, LLC to be my lawful attorney-in-fact to act for
(company name)

me and apply to the City of Belle Isle Building Department for a WINDOW/DOOR permit
(type of permit)

for work to be performed at the following location:

2844 MONTMART DR, Belle Isle, FL 32809 32812 and
(street address)

to sign my name and do all things necessary to this appointment.

Certified Contractor's Printed Name: PETER ANTHONY CAFARO III

License Number: CGC1508417

Certified Contractor's Signature: _____

The foregoing instrument was acknowledged before me this 26 days of MARCH of 20 20

by PETER CAFARO who is personally known to me or who produced

_____ as identification and who did not take an oath.

State of Florida
 County of Orange

 Notary Public, Orange County, Florida





City of Belle Isle
 Universal Engineering Sciences 3532 Maggie Blvd., Orlando, FL 32811
 Tel 407-581-8161 * Fax 407-581-0313 * www.universaleengineering.com

Product Approval Form

DATE: 3/26/20 PERMIT # 2020-04-039
 PROJECT ADDRESS 2844 MONTMART DR Belle Isle, FL 32809 / 32812

As required by Florida Statute 563.842 and Florida Administrative Code 9B-72m, please provide the information and approval numbers of the building components listed below if they will be utilized on the building or structure. FL Approved products are listed online at www.floridabuilding.org or can be obtained from the local product supplier. The following information must be turned in with permit application and available onsite for inspections:

• **NOTE: The installation instructions must be posted on-site before your first inspection!**

Product Type	Manufacturer	Model/Series	FL Product Approval #	Product Type	Manufacturer	Model/Series	FL Product Approval #
EXTERIOR DOORS				WALL PANELS			
Swinging	<u>Pella</u>		<u>1480168</u>	Sliding			
Sliding				Soffits			
Sectional/Rollup				Storefront			
Other				Glass Block			
				Other			
WINDOWS				ROOFING PRODUCTS			
Single/Dbf Hung				Asphalt Shingles			
Horizontal Slider				Non Struct Metal			
Casement				Roofing Tiles			
Fixed				Single Ply Roof			
Mullion				Underlayment			
Wylights				Other			
Other							
STRUCTURAL COMPONENTS				OTHER			
Wood Connectors							
Wood Anchors							
Truss Plates							
Insulation Forms							
Lintels							
Other							

It is the applicant's responsibility to verify that specific products have been installed in accordance with their limitations and with the minimum required design pressures for the structure. Specific compliance will be verified during field inspections.

Applicant Signature 

Date 3/26/20



[BCIS Home](#) | [Log In](#) | [User Registration](#) | [Hot Topics](#) | [Submit Surcharge](#) | [Stats & Facts](#) | [Publications](#) | [Contact Us](#) | [BCIS Site Map](#) | [Links](#) | [Search](#)



Product Approval
USER: Public User

[Product Approval Menu](#) > [Product or Application Search](#) > [Application List](#) > **Application Detail**

OFFICE OF THE SECRETARY

FL #	FL14896-R5	<i>8 version</i>
Application Type	Revision	
Code Version	2017	
Application Status	Approved	
	*Approved by DBPR. Approvals by DBPR shall be reviewed and ratified by the POC and/or the Commission if necessary.	
Comments		
Archived	<input type="checkbox"/>	
Product Manufacturer	Pella Corporation	
Address/Phone/Email	102 Main St. Pella, IA 50219 (641) 621-6096 pellaproductapproval@pella.com	
Authorized Signature	Justin McAninch mcaninchjm@pella.com	
Technical Representative	Joseph Hayden	
Address/Phone/Email	102 Main Street Pella, IA 50219 (641) 621-6096 jahayden@pella.com	
Quality Assurance Representative	Pat Bortscheller	
Address/Phone/Email	102 Main Street Pella, IA 50219 (641) 621-1000 PJBortscheller@pella.com	
Category	Exterior Doors	
Subcategory	Swinging Exterior Door Assemblies	
Compliance Method	Certification Mark or Listing	
Certification Agency	Window and Door Manufacturer Association	
Validated By	Terrence E. Lunn, PE	
	<input checked="" type="checkbox"/> Validation Checklist - Hardcopy Received	
Referenced Standard and Year (of Standard)	Standard ASTM E330	Year 2002
Equivalence of Product Standards Certified By		
Product Approval Method	Method 1 Option A	
Date Submitted	04/12/2019	
Date Validated	04/15/2019	

may be full or partial light panel. Reinforced mullions horizontal and vertical. Standard or ADA sills apply		FL14896_R5_AE_Drawing_1774.pdf Created by Independent Third Party: Yes
14896.6	Pella & Architect Series Steel & Fiberglass Panel In-swing Doors with Aluminum Clad Frame	43 1/2" X 97 3/4" single solid operable door with standard latch and deadbolt, reinforced mullion, dual sidelights, and a transom (76 1/2" X 135" overall unit size).
Limits of Use Approved for use in HVHZ: No Approved for use outside HVHZ: Yes Impact Resistant: No Design Pressure: +40/-40 Other: Lock system with door shall be standard latch and deadbolt. Configurations of glass shall conform to the current ASTM E1300 standard & have safety rated glass. Sidelight panel may be full or partial light panel. Reinforced mullions horizontal and vertical. Standard or ADA sills apply		Certification Agency Certificate FL14896_R5_C_CAC_FL14896_6.pdf Quality Assurance Contract Expiration Date 08/11/2021 Installation Instructions FL14896_R5_II_Drawing_1774.pdf Verified By: Warren W. Schaefer, P.E. 44135 Created by Independent Third Party: Yes Evaluation Reports FL14896_R5_AE_Drawing_1774.pdf Created by Independent Third Party: Yes
14896.7	Pella & Architect Series Steel & Fiberglass Panel In-swing Doors with Aluminum Clad Frame	37 1/2" X 97 3/4" single glazed operable door with 3-point lock, reinforced mullions, dual sidelights, and a transom (70 1/2" X 135" overall unit size).
Limits of Use Approved for use in HVHZ: No Approved for use outside HVHZ: Yes Impact Resistant: No Design Pressure: +50/-50 Other: Lock system with door shall be 3-Point Lock. Configurations of glass shall conform to the current ASTM E1300 standard & have safety rated glass. Door panel may be full or partial light panel. Reinforced mullions horizontal and vertical.		Certification Agency Certificate FL14896_R5_C_CAC_FL14896_7.pdf Quality Assurance Contract Expiration Date 06/27/2021 Installation Instructions FL14896_R5_II_Drawing_1774.pdf Verified By: Warren W. Schaefer, P.E. 44135 Created by Independent Third Party: Yes Evaluation Reports FL14896_R5_AE_Drawing_1774.pdf Created by Independent Third Party: Yes
14896.8	Pella & Architect Series Steel & Fiberglass Panel In-swing Doors with Aluminum Clad Frame	43 1/2" X 97 3/4" single solid operable door with 3-point lock, reinforced mullion, dual sidelights, and a transom (76 1/2" X 135" overall unit size).
Limits of Use Approved for use in HVHZ: No Approved for use outside HVHZ: Yes Impact Resistant: No Design Pressure: +50/-50 Other: Lock system with door shall be 3-Point Lock. Configurations of glass shall conform to the current ASTM E1300 standard & have safety rated glass. Sidelight panel may be full or partial light panel. Reinforced mullions horizontal and vertical.		Certification Agency Certificate FL14896_R5_C_CAC_FL14896_8.pdf Quality Assurance Contract Expiration Date 09/22/2021 Installation Instructions FL14896_R5_II_Drawing_1774.pdf Verified By: Warren W. Schaefer, P.E. 44135 Created by Independent Third Party: Yes Evaluation Reports FL14896_R5_AE_Drawing_1774.pdf Created by Independent Third Party: Yes
14896.9	Pella & Architect Series Steel & Fiberglass Panel In-swing Doors with Aluminum Clad or Wood Frame	74 7/8" x 97 3/4" double operable solid door with 2-point multi-point lock at inactive panel and single lock & dead bolt at active panel
Limits of Use Approved for use in HVHZ: No Approved for use outside HVHZ: Yes Impact Resistant: No Design Pressure: +40/-40 Other: Standard or ADA sills apply		Certification Agency Certificate FL14896_R5_C_CAC_FL14896_9.pdf Quality Assurance Contract Expiration Date 09/15/2021 Installation Instructions FL14896_R5_II_Drawing_1774.pdf Verified By: Warren W. Schaefer, P.E. 44135 Created by Independent Third Party: Yes Evaluation Reports FL14896_R5_AE_Drawing_1774.pdf Created by Independent Third Party: Yes
14896.10	Pella & Architect Series Steel & Fiberglass Panel In-swing Doors with Aluminum Clad or Wood Frame	74 7/8" x 97 3/4" double operable solid door with 2-point multi-point lock at inactive panel and 3-point multi-point lock at active panel
Limits of Use Approved for use in HVHZ: No Approved for use outside HVHZ: Yes Impact Resistant: No Design Pressure: +40/-40 Other: Standard or ADA sills apply		Certification Agency Certificate FL14896_R5_C_CAC_FL14896_10.pdf Quality Assurance Contract Expiration Date 09/15/2021 Installation Instructions FL14896_R5_II_Drawing_1774.pdf Verified By: Warren W. Schaefer, P.E. 44135 Created by Independent Third Party: Yes Evaluation Reports FL14896_R5_AE_Drawing_1774.pdf Created by Independent Third Party: Yes
14896.11	Pella & Architect Series Steel & Fiberglass Panel In-swing Doors with Aluminum Clad or Wood Frame	86 7/8" x 97 3/4" double operable solid door with 2-point multi-point lock at inactive panel and either 3-point multi-point lock or single lock & dead bolt at active panel

2844 MONTREAT 01.

ALTERNATE ANCHOR/SUBSTRATE EVALUATION NOTE:
 ALL ALTERNATE ANCHORS IN THEIR SPECIFIED SUBSTRATES HAVE BEEN ANALYZED IN ACCORDANCE WITH THEIR APPLICABLE STANDARD(S) AND ARE FOUND TO BE EQUIVALENT TO OR STRONGER THAN THE ANCHOR(S) USED IN TESTING WITH THIS PRODUCT.

INSTALLATION EVALUATION IS BASED ON APPLICABLE ANCHOR STANDARDS AND/OR INFORMATION & RESULTS FROM APPLICABLE TEST REPORTS. THE FLORIDA BUILDING CODE VERSION CONSIDERED WITH THE EVALUATION WAS THAT IN FORCE AT THE TIME OF THE EVALUATION. IN THE EVENT OF CODE VERSION CHANGES/UPDATES OR IN THE EVENT THAT NEW OR ADDITIONAL TESTING IS COMPLETED ON THE REFERENCED PRODUCT, PRIOR TO STATING CODE COMPLIANCE WITH THE STATE, THE MANUFACTURER SHALL CONFIRM WITH THE INSTALLATION EVALUATION ENGINEER OF RECORD THAT THE INSTALLATIONS SPECIFIED HERE-IN ARE CURRENT WITH THE THEN CURRENT TESTING, CODE AND APPLICABLE STANDARDS.

FRAME ANCHOR REQUIREMENTS TABLE

OPENING TYPE (SUBSTRATE)	FRAME/CLIP/HINGE/STRIKE TO OPENING FASTENER TYPE	MINIMUM EMBED	MINIMUM EDGE DIST.
FRAME SCREWS			
(3) MIN. 2X_ WOOD FRAME OR BUCK (MIN. GR. 3 & G=0.55)	NO. 10 SMS OR WOOD SCREW	1 1/4"	3/4"
MIN. 18 GA. 33 KSI METAL STUD	NO. 10 GR. 5 SELF TAP/DRILL SCREW	FULL	1/2"
MIN. 1/8" THK A36 STEEL	NO. 10 GR. 5 SELF TAP/DRILL SCREW	FULL	1/2"
MIN. 1/8" THK 6063-T5 ALUM.	NO. 10 GR. 5 SELF TAP/DRILL SCREW	FULL	1/2"
C-90 CMU/2500 PSI CONCRETE	(1) 1/4" CONCRETE SCREW	1 1/4"	2"

(2) INSTALLATION CLIP SCREWS (STANDARD BENT CONDITION)			
MIN. 2X4 WOOD FRAME OR BUCK (MIN. GR. 3 & G=0.55)	NO. 8 X 1 1/2" SMS	1 3/8"	(2) N/A
MIN. 1/8" THK A36 STEEL	NO. 8 GR. 5 SELF TAP/DRILL SCREW	FULL	(2) N/A
MIN. 1/8" THK 6063-T5 ALUM.	NO. 8 GR. 5 SELF TAP/DRILL SCREW	FULL	(2) N/A

INSTALLATION CLIP SCREWS (ALTERNATE STRAIGHT CONDITION)			
MIN. 2X6 WOOD FRAME OR BUCK (MIN. GR. 3 & G=0.55)	NO. 8 X 1 1/2" SMS	1 3/8"	3/4"
MIN. 18 GA. 33 KSI METAL STUD	NO. 8 GR. 5 SELF TAP/DRILL SCREW	FULL	1/2"
MIN. 1/8" THK A36 STEEL	NO. 8 GR. 5 SELF TAP/DRILL SCREW	FULL	1/2"
MIN. 1/8" THK 6063-T5 ALUM.	NO. 8 GR. 5 SELF TAP/DRILL SCREW	FULL	1/2"

HINGE & SINGLE DOOR STRIKE SCREWS			
(3) MIN. 2X_ WOOD FRAME OR BUCK (MIN. GR. 3 & G=0.55)	NO. 8 SMS OR WOOD SCREW	1 1/4"	3/4"
MIN. 18 GA. 33 KSI METAL STUD	NO. 8 GR. 5 SELF TAP/DRILL SCREW	FULL	1/2"
MIN. 1/8" THK A36 STEEL	NO. 8 GR. 5 SELF TAP/DRILL SCREW	FULL	1/2"
MIN. 1/8" THK 6063-T5 ALUM.	NO. 8 GR. 5 SELF TAP/DRILL SCREW	FULL	1/2"
C-90 CMU/2500 PSI CONCRETE	(1) 3/16" CONCRETE SCREW	1 1/4"	2"

DOUBLE DOOR STRIKE SCREWS			
MIN. 2X_ WOOD FRAME OR BUCK (MIN. GR. 3 & G=0.55)	NO. 12 SMS OR WOOD SCREW	1 1/4"	3/4"
MIN. 18 GA. 33 KSI METAL STUD	NO. 12 GR. 5 SELF TAP/DRILL SCREW	FULL	1/2"
MIN. 1/8" THK A36 STEEL	NO. 12 GR. 5 SELF TAP/DRILL SCREW	FULL	1/2"
MIN. 1/8" THK 6063-T5 ALUM.	NO. 12 GR. 5 SELF TAP/DRILL SCREW	FULL	1/2"
C-90 CMU/2500 PSI CONCRETE	(1) 1/4" CONCRETE SCREW	1 1/4"	2"

(4) NAILING FIN FASTENERS			
MIN. 2X4 WOOD FRAME OR BUCK (MIN. GR. 3 & G=0.55)	NO. 8 X 1 1/2" SMS	1 3/8"	1/2"
MIN. 2X4 WOOD FRAME OR BUCK (MIN. GR. 3 & G=0.55)	11 GA. ROOFING NAIL	1 3/8"	1/2"
MIN. 1/8" THK A36 STEEL	NO. 8 GR. 5 SELF TAP/DRILL SCREW	FULL	1/2"
MIN. 1/8" THK 6063-T5 ALUM.	NO. 8 GR. 5 SELF TAP/DRILL SCREW	FULL	1/2"

- (1) CONCRETE SCREWS SHALL BE ELCO ULTRACONS, ELCO CRETE-FLEX, ITW RAMSET/RED HEAD TAPCONS OR HILTI KWIK-CON II (HARDENED STEEL OR S.S.).
- (2) STANDARD BENT CLIP INSTALLATION SCREWS SHALL BE POSITIONED WITHIN 1/4" OF THE BUCK/SUBSTRATE EDGE AND, IF INTO WOOD, ANGLED 20 TO 30 DEGREES INTO THE BUCK.
- (3) 2X_ BUCKS SHALL BE OF A MINIMUM DEPTH REQUIRED TO MEET ANCHOR EDGE DISTANCE REQUIREMENTS BUT NO LESS THAN 4 1/2" (2X4).
- (4) WHEN SCREWS ARE USED WITH THE NAIL FIN, THEY MUST BE A WAFFLE HEAD SCREW OR HAVE A FLAT WASHER AT THE SCREW HEAD.

NOTE: ALL ELEVATIONS SHOWN HERE-IN ARE FOR USE IN DETAILING THE INSTALLATION OF THE DOORS ONLY. TYPE, SHAPE & CONDITIONS RELATIVE TO THE DOOR PANELS & DOOR FRAMES SHALL BE GOVERNED BY THE DOORS PRODUCT APPROVAL & SHALL BE AS CERTIFIED BY THE APPLICABLE CERTIFICATION ENTITY.

HINGE REQUIREMENTS	
MAX. FRAME HEIGHT	QUANTITY PER PANEL
OVER 85 3/4"	4
85 3/4"	3

EDGE DISTANCE MAY BE DECREASED TO 1/2" IF SCREWS ARE ANGLED 15 TO 20 DEGREES AWAY FROM THE EDGE.

- GENERAL NOTES:**
- ALL FASTENERS SHALL BE IN ACCORDANCE WITH THESE DRAWINGS. SPECIFIED ANCHOR EMBED TO BASE MATERIAL SHALL BE BEYOND WALL FINISH OR STUCCO.
 - OPENINGS, BUCKING & BUCKING FASTENERS MUST BE PROPERLY DESIGNED & INSTALLED TO TRANSFER WIND LOADS TO THE STRUCTURE.
 - THESE NON-IMPACT RATED PRODUCT INSTALLATIONS ARE IN ACCORDANCE WITH AND MEET THE REQUIREMENTS OF THE FLORIDA BUILDING CODE (FBC).
 - ALL ANCHORS SECURING PRODUCT FRAMES TO PRESSURE TREATED BUCKS OR WOOD FRAMING SHALL BE CAPABLE OF RESISTING CORROSION CAUSED BY THE PRESSURE TREATING CHEMICALS IN THE WOOD.
 - MATERIALS, INCLUDING BUT NOT LIMITED TO STEEL SCREWS, THAT COME INTO CONTACT WITH OTHER DISSIMILAR MATERIALS SHALL MEET THE REQUIREMENTS OF FLORIDA BUILDING CODE CHAPTER 20.
 - TO THE BEST OF OUR KNOWLEDGE, THE PRODUCT SHOWN HEREIN IS CERTIFIED & QUALITY ASSURED BY A FLORIDA STATE APPROVED CERTIFICATION/QA ENTITY & SHALL BE LABELED IN ACCORDANCE WITH THE FBC AND THE FLORIDA DEPARTMENT OF BUSINESS & PROFESSIONAL REGULATION SPECIFICATIONS. PRODUCT ASSEMBLY IS NOT PART OF THIS DRAWING AND SHALL BE IN ACCORDANCE WITH THE MANUFACTURER'S QUALITY ASSURANCE SPECIFICATIONS & TESTING REPORTS.
 - CERTIFICATION OF THESE PRODUCT INSTALLATIONS SHALL BE CONSIDERED VOID IF ANY OF THE FOLLOWING APPLY: 1) PRODUCT IS INSTALLED WITHOUT A BUILDING PERMIT FROM THE APPLICABLE LOCAL BUILDING DEPARTMENT. 2) PRODUCT IS INSTALLED BY ANYONE OTHER THAN A LICENSED CONTRACTOR EXPERIENCED WITH INSTALLATIONS OF THIS TYPE OF PRODUCT. 3) IF CHANGES HAVE OCCURRED TO THE PRODUCT'S CERTIFICATION ENTITY'S CERTIFICATE THAT CAUSE THESE INSTALLATIONS TO BE INCORRECT OR INCONSISTENT WITH WHAT HAS BEEN TESTED.
 - THE LEAST DESIGN PRESSURE SPECIFIED EITHER IN THIS DRAWING OR IN THE PRODUCTS CERTIFICATION SHALL CONTROL FOR THE INSTALLED PRODUCT.
 - THESE DRAWINGS CERTIFY THE PRODUCT INSTALLATION ONLY. WATER PROOFING OF THE INSTALLED PRODUCT IS NOT PART OF THIS INSTALLATION CERTIFICATION. THAT RESPONSIBILITY SHALL BE THAT OF THE MANUFACTURER &/OR INSTALLER.

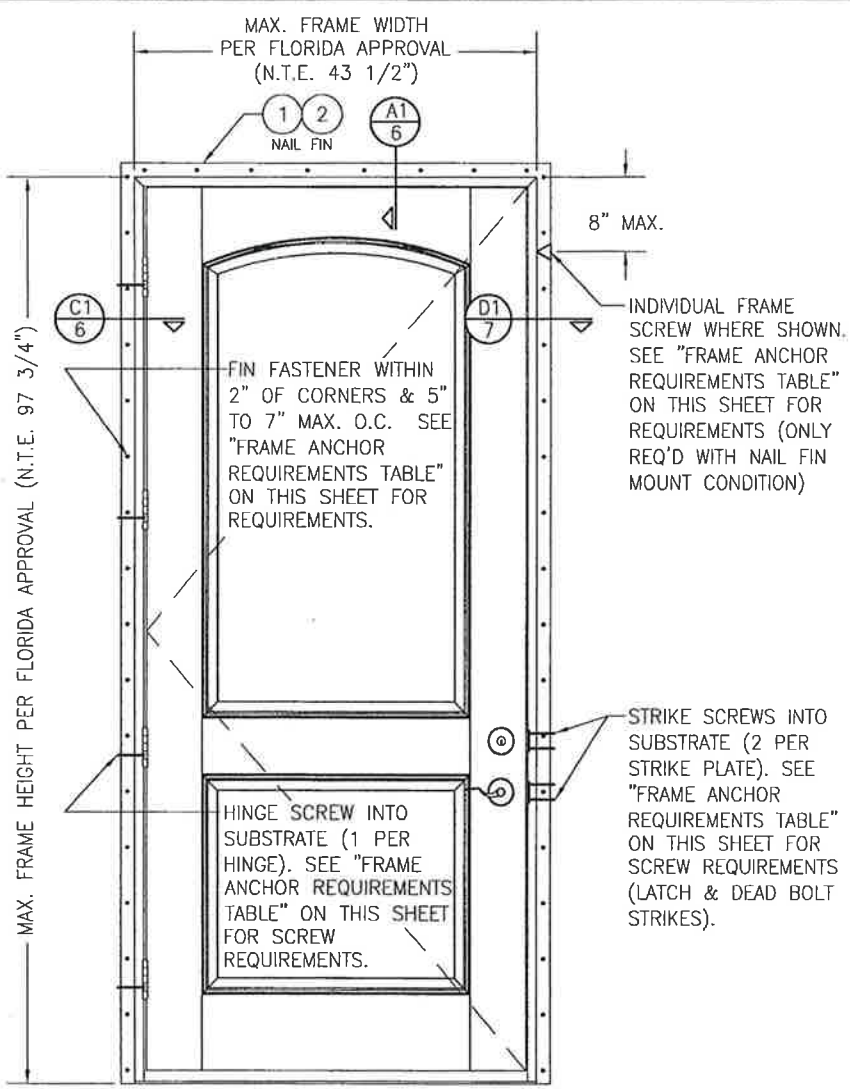

INTERIOR ELEVATION:
SINGLE DOOR WITH DEADBOLT LOCKING SYSTEM
 SCALE: 3/4" = 1'-0"
 (NAIL FIN MOUNT CONDITION)
 ALLOWABLE DESIGN PRESSURE
 (SINGLE DOOR)
 SEE FLORIDA APPROVAL

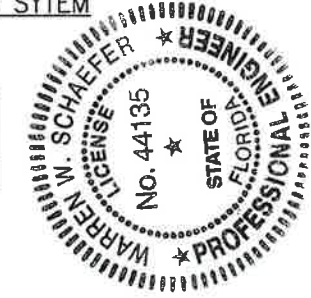

THESE DRAWINGS ARE APPLICABLE ONLY TO THE PRODUCT SPECIFIED. THEY MAY NOT BE USED FOR THE ASSEMBLY AND/OR INSTALLATION OF ANY OTHER PRODUCT NOR MAY THEY BE USED FOR RATIONAL AND/OR LOCAL APPROVAL OF ANY PRODUCT NOT PRODUCED BY THE MANUFACTURER STATED ON THESE DRAWINGS.

DRAWN BY: W.R.M.	CHECKED BY: W.W.S.	PLOT: 1-16	DATE: 09/23/11
DATE: 11/28/11	BY: W.R.M.	REVISION DESCRIPTION: A1 UPDATE PER NEW TESTING	NO.:
DATE: 04/23/15	BY: W.W.S.	REVISION DESCRIPTION: B1 UPDATE TO CURRENT STANDARDS	NO.:
DRAWING TITLE: PELLA & ARCHITECT SERIES STEEL & FIBERGLASS PANEL IN-SWING NON-IMPACT CLAD & WOOD FRAME DOORS			
CONSULTANTS: W. W. SCHAEFER ENGINEERING & CONSULTING, P.A. (CA 6809) 7480 150TH COURT, NORTH PALM BEACH GARDENS, FL 33418 PHONE: 561-744-3424		MANUFACTURER: PELLA CORPORATION 102 MAIN STREET PELLA, IA 50219 641-621-1000	
CERTIFICATION: APR 28 2015 WARREN W. SCHAEFER, P.E. LICENSE NO. 44135			
DRAWING NO. 1774		REV. B	
SHEET NO. 1		OF 8	

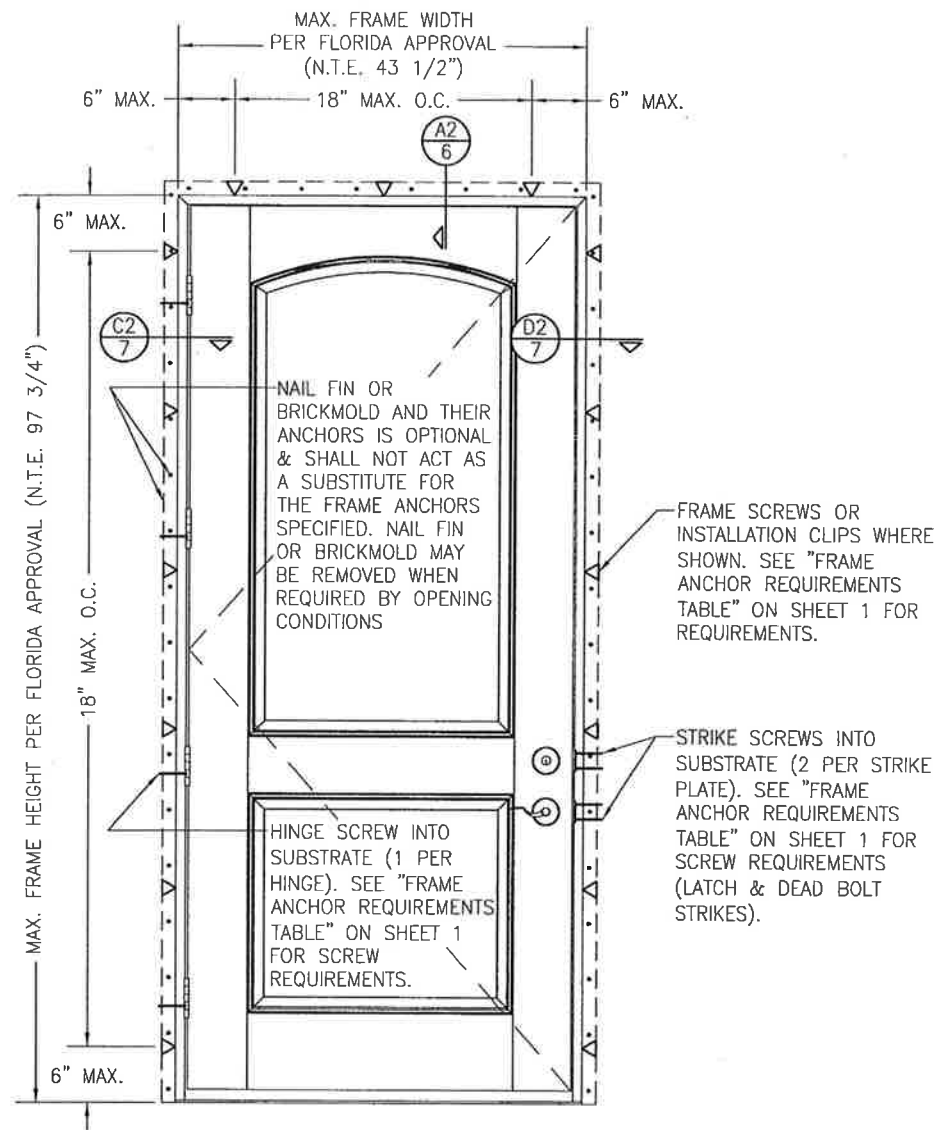

INTERIOR ELEVATION:
SINGLE DOOR WITH DEADBOLT LOCKING SYSTEM
 SCALE: 3/4" = 1'-0"
 (FRAME SCREW & CLIP MOUNT CONDITIONS)

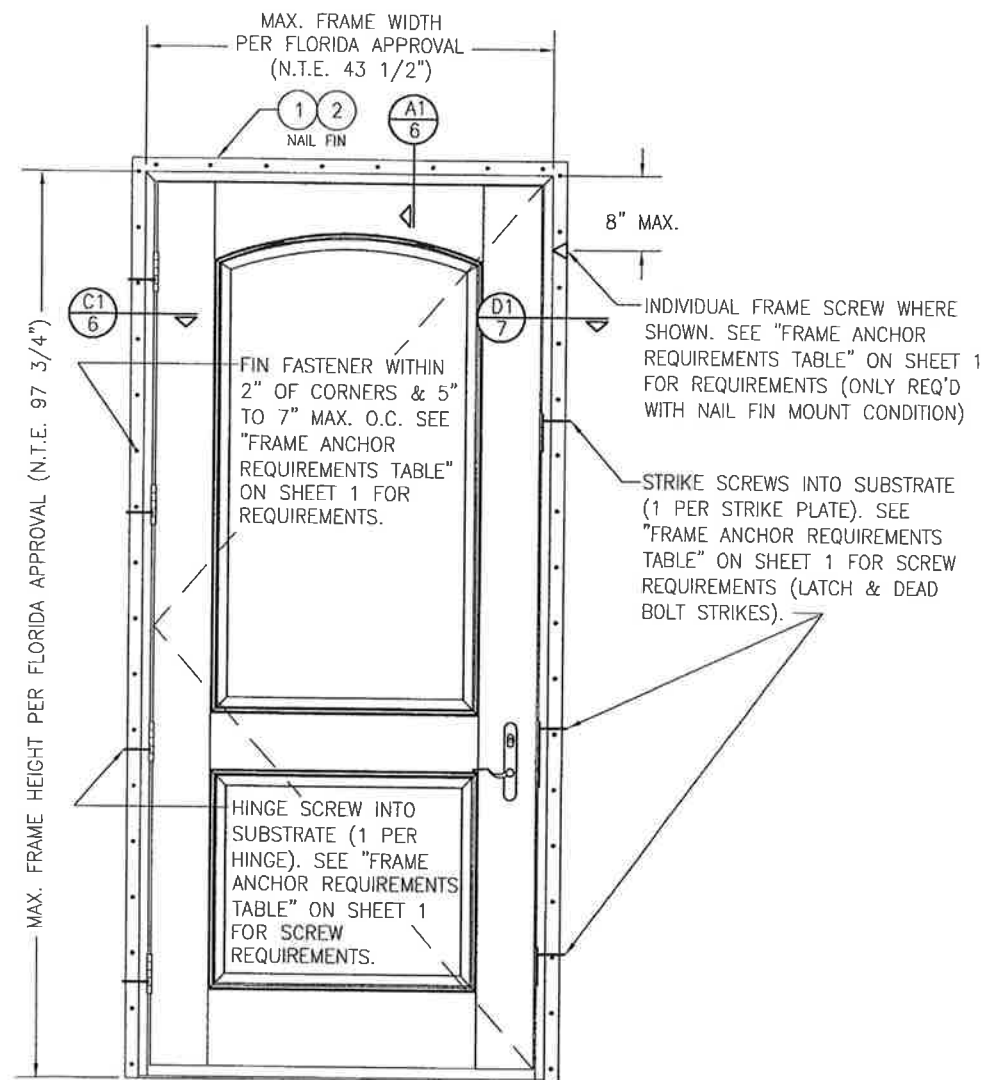

INTERIOR ELEVATION:
SINGLE DOOR WITH MULTIPPOINT LOCKING SYSTEM
 SCALE: 3/4" = 1'-0"
 (NAIL FIN MOUNT CONDITION)

ALLOWABLE DESIGN PRESSURE
 (SINGLE DOOR)
 SEE FLORIDA APPROVAL



DRAWN BY: W.R.M.		CHECKED BY: W.W.S.	
PLOT: 1-16		DATE: 09/23/11	
NO.	REVISION DESCRIPTION	BY	DATE
DRAWING TITLE: PELLA & ARCHITECT SERIES STEEL & FIBERGLASS PANEL IN-SWING NON-IMPACT CLAD & WOOD FRAME DOORS			
CONSULTANTS: W. W. SCHAEFER ENGINEERING & CONSULTING, P.A. (CA 6809) 7480 150TH COURT NORTH PALM BEACH GARDENS, FL 33418 PHONE: 561-744-3424		PELLA CORPORATION 102 MAIN STREET PELLA, IA 50219 641-621-1000	
CERTIFICATION: APR 23 2015		WARREN W. SCHAEFER, P.E. P.E. NO. 44135	
DRAWING NO. 1774		REV. B	
SHEET NO. 2 OF 8			

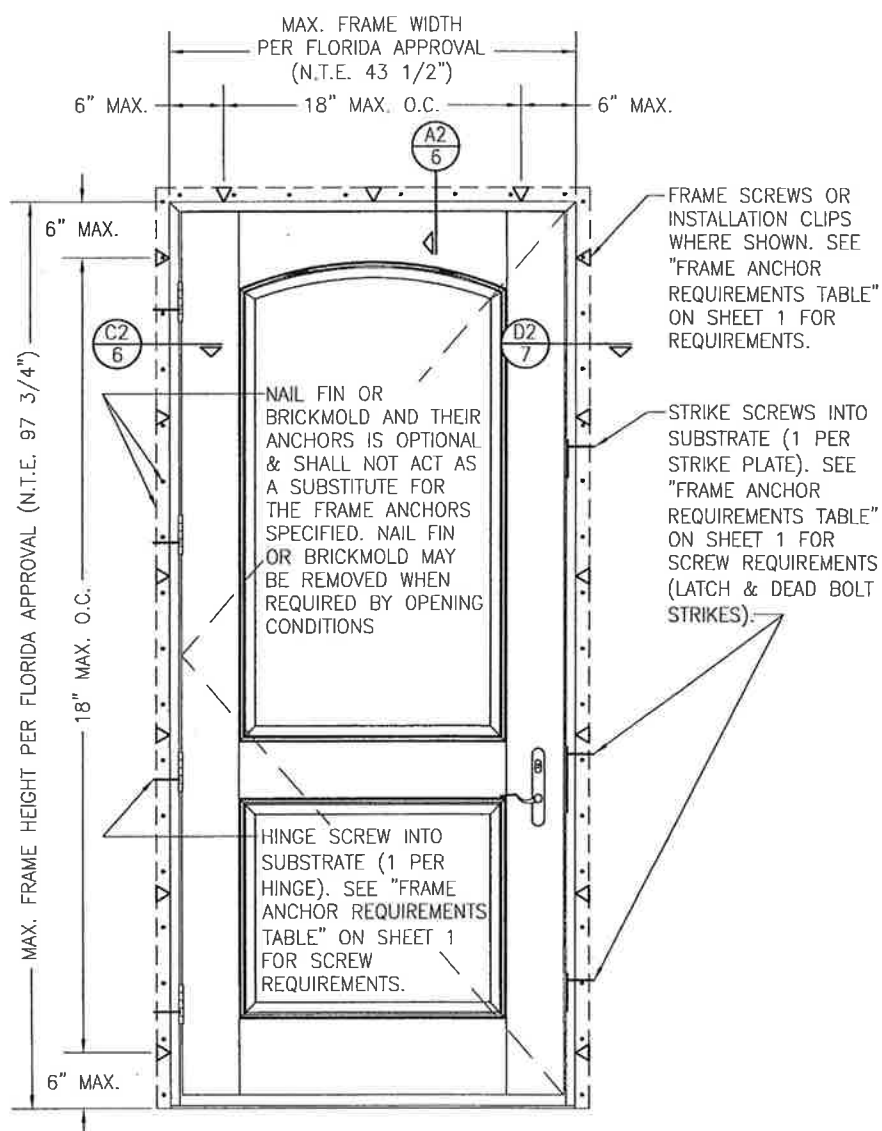

**INTERIOR ELEVATION:
SINGLE DOOR WITH MULTIPOINT LOCKING SYSTEM**
SCALE: 3/4" = 1'-0"
(FRAME SCREW & CLIP MOUNT CONDITIONS)

ALLOWABLE DESIGN PRESSURE
(SINGLE DOOR)
SEE FLORIDA APPROVAL

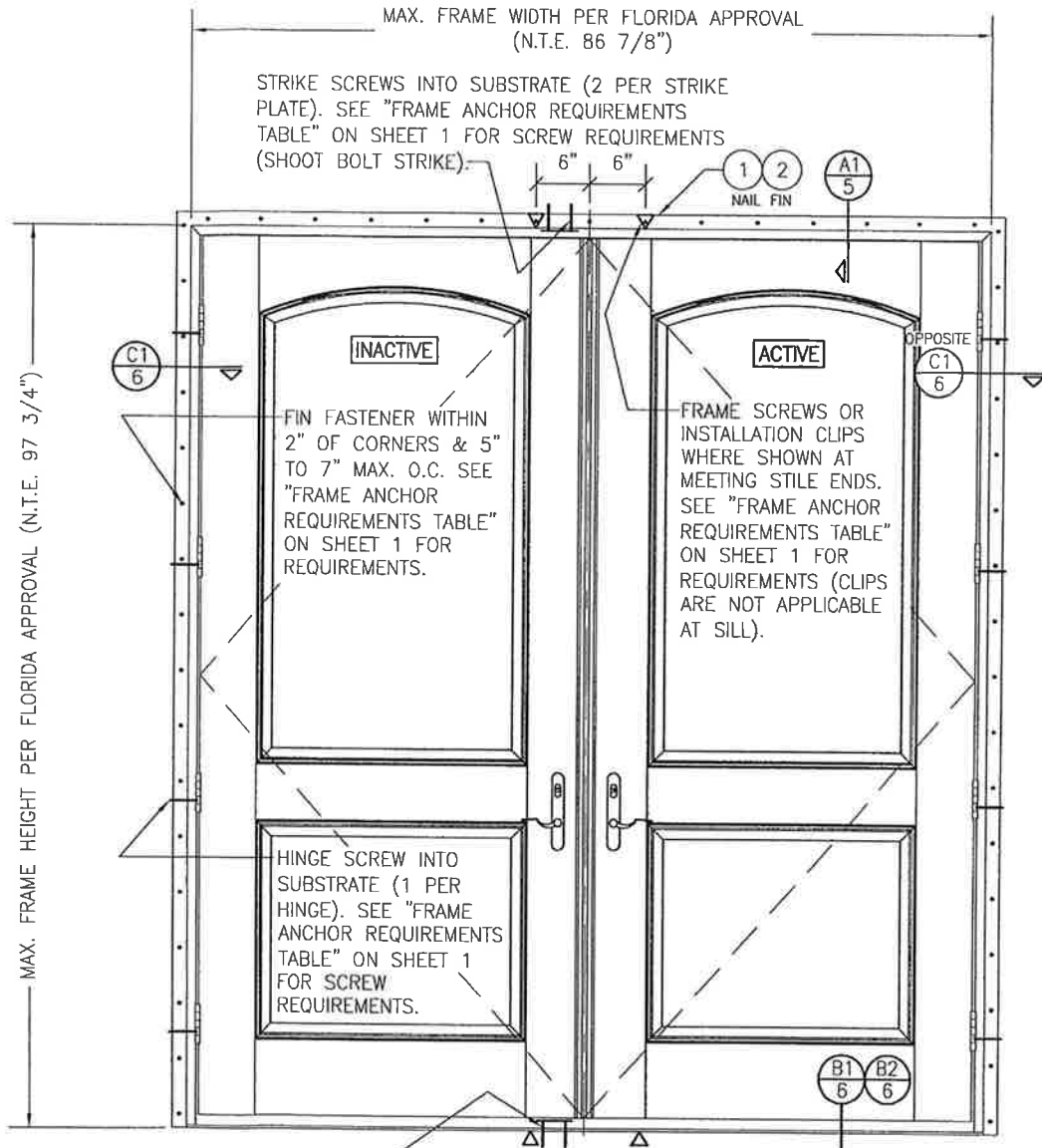

STRIKE SCREWS INTO SUBSTRATE (2 PER STRIKE PLATE WITH STANDARD SILL; 1 PER STRIKE WITH ADA SILL). SEE "FRAME ANCHOR REQUIREMENTS TABLE" ON SHEET 1 FOR SCREW REQUIREMENTS (SHOOT BOLT STRIKE).

**INTERIOR ELEVATION:
DOUBLE DOORS**
SCALE: 3/4" = 1'-0"
(NAIL FIN MOUNT CONDITION)

ALLOWABLE DESIGN PRESSURE
(DOUBLE DOOR)
SEE FLORIDA APPROVAL



DRAWN BY: W.R.M.	CHECKED BY: W.W.S.
PLOT: 1-16	DATE: 09/23/11
DATE	BY
REVISION DESCRIPTION	
NO.	
DRAWING TITLE PELLA & ARCHITECT SERIES STEEL & FIBERGLASS PANEL IN-SWING NON-IMPACT CLAD & WOOD FRAME DOORS	
CONSULTANTS W. W. SCHAEFER ENGINEERING & CONSULTING, P.A. (CA 6809)	MANUFACTURER PELLA CORPORATION 102 MAIN STREET PELLA, IA 50219 641-621-1000
7480 150TH COURT NORTH PALM BEACH GARDENS, FL 33418 PHONE: 561-744-3424	
CERTIFICATION APR 23 2015	WARREN W. SCHAEFER, P.E. P.E. NO. 44135
DRAWING NO. 1774	REV. B
SHEET NO. 3	OF 8

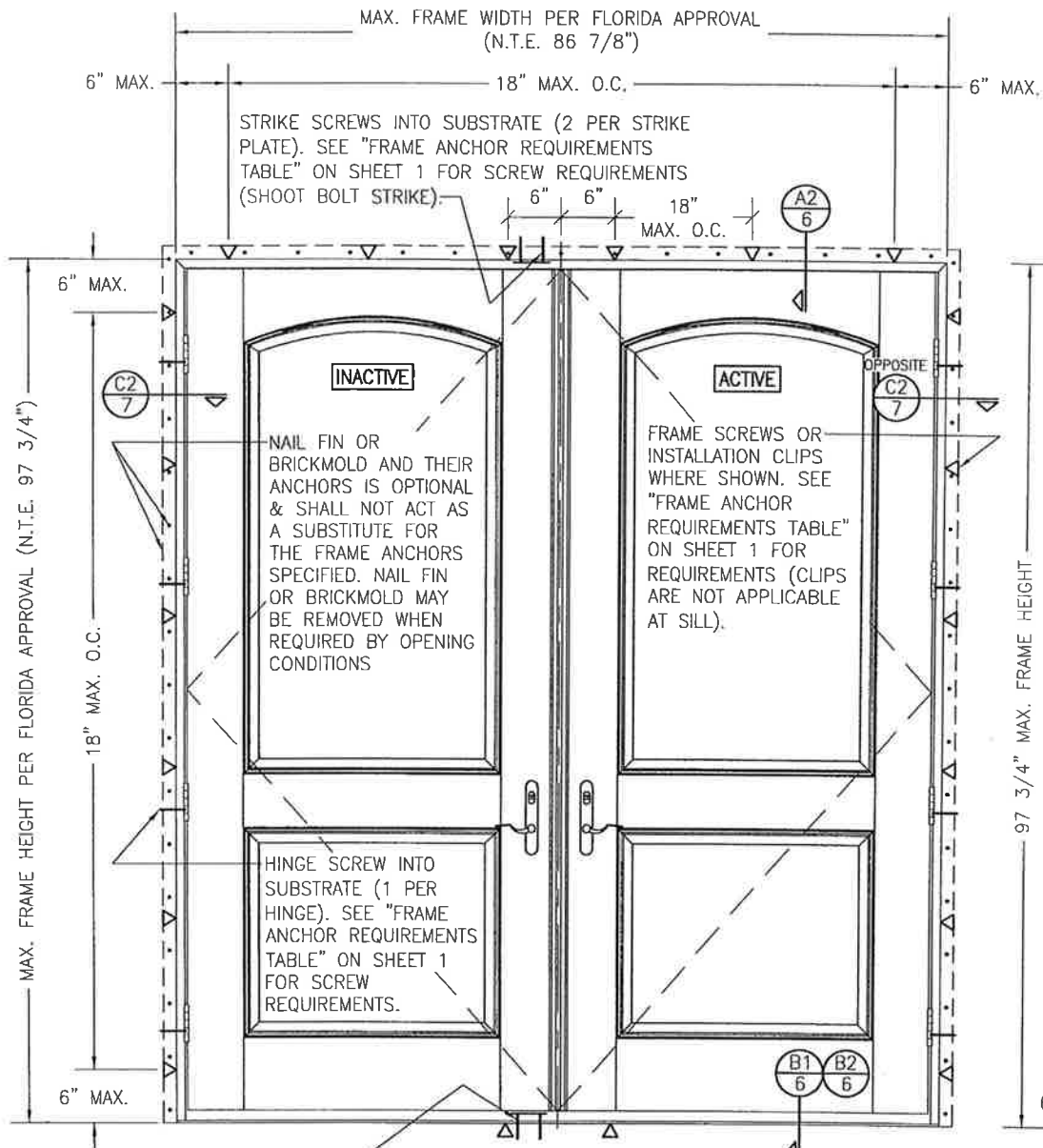

STRIKE SCREWS INTO SUBSTRATE (2 PER STRIKE PLATE WITH STANDARD SILL; 1 PER STRIKE WITH ADA SILL). SEE "FRAME ANCHOR REQUIREMENTS TABLE" ON SHEET 1 FOR SCREW REQUIREMENTS (SHOOT BOLT STRIKE).

**INTERIOR ELEVATION:
DOUBLE DOORS**

SCALE: 3/4" = 1'-0"

ALLOWABLE DESIGN PRESSURE
(DOUBLE DOOR)
SEE FLORIDA APPROVAL

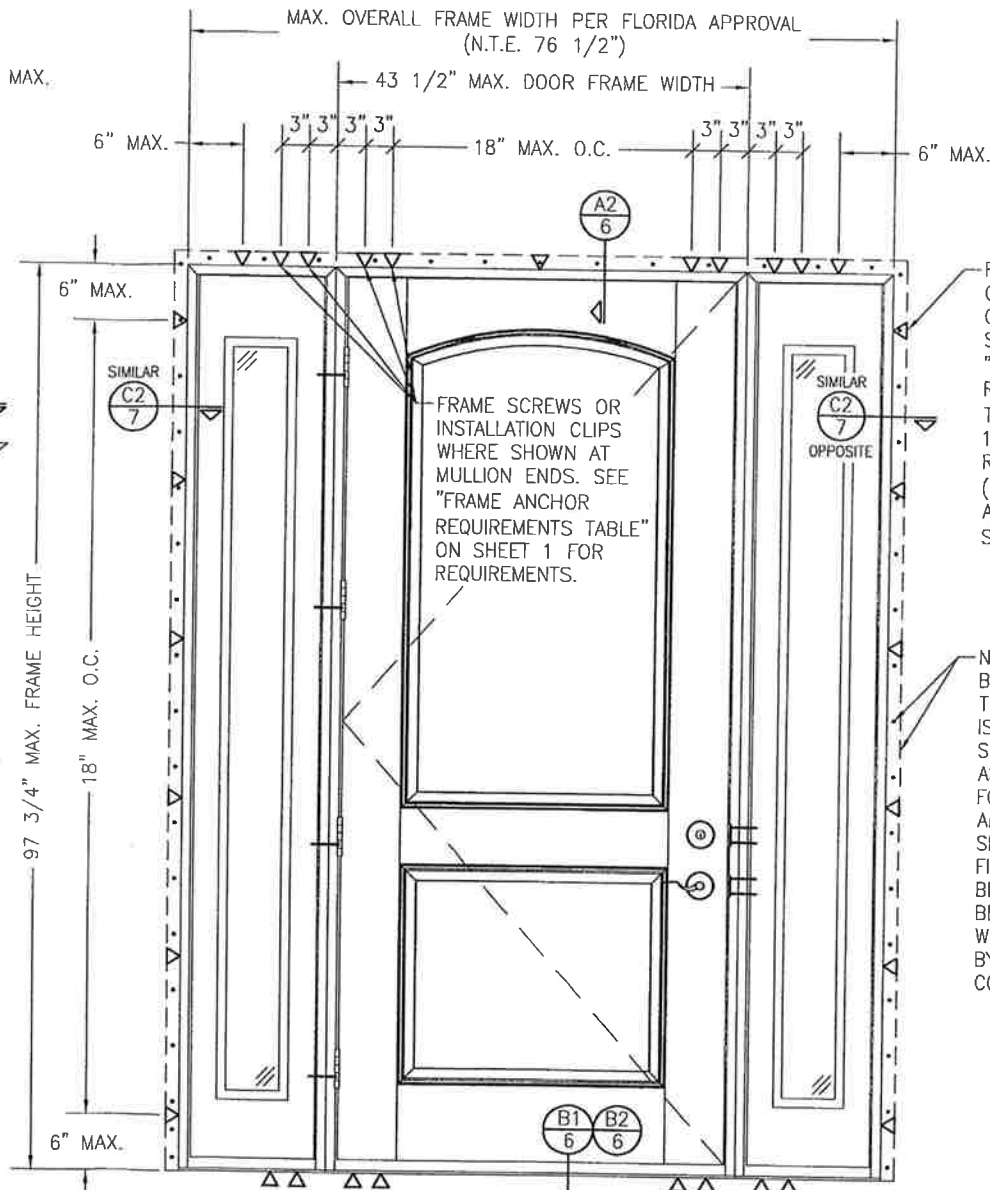

FRAME SCREWS OR INSTALLATION CLIPS WHERE SHOWN AT MULLION ENDS. SEE "FRAME ANCHOR REQUIREMENTS TABLE" ON SHEET 1 FOR REQUIREMENTS (CLIPS ARE NOT APPLICABLE AT SILL).

NAIL FIN OR BRICKMOLD AND THEIR ANCHORS IS OPTIONAL & SHALL NOT ACT AS A SUBSTITUTE FOR THE FRAME ANCHORS SPECIFIED. NAIL FIN OR BRICKMOLD MAY BE REMOVED WHEN REQUIRED BY OPENING CONDITIONS.

**INTERIOR ELEVATION:
SINGLE DOOR WITH SIDELIGHTS**

SCALE: 3/4" = 1'-0"

(THIS ELEVATION IS APPLICABLE TO SCREW & CLIP MOUNT INSTALLATION ONLY)

ALLOWABLE DESIGN PRESSURE
(SINGLE DOOR WITH SIDELIGHTS)
SEE FLORIDA APPROVAL

DRAWN BY: W.R.M.	CHECKED BY: W.W.S.
DATE: 09/23/11	
NO.	REVISION DESCRIPTION

PELLA & ARCHITECT SERIES STEEL & FIBERGLASS PANEL
IN-SWING NON-IMPACT CLAD & WOOD FRAME DOORS

MANUFACTURER
Pella

PELLA CORPORATION
102 MAIN STREET
PELLA, IA 50219
641-621-1000

CONSULTANTS
W. SCHAEFER ENGINEERING
& CONSULTING, P.A. (CA 6809)
7480 150TH COURT NORTH
PALM BEACH GARDENS, FL 33418
PHONE: 561-744-3424

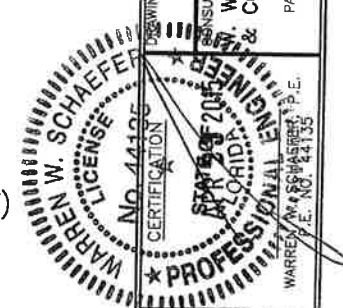

DRAWING NO. 1774	REV. B
SHEET NO. 4 OF 8	

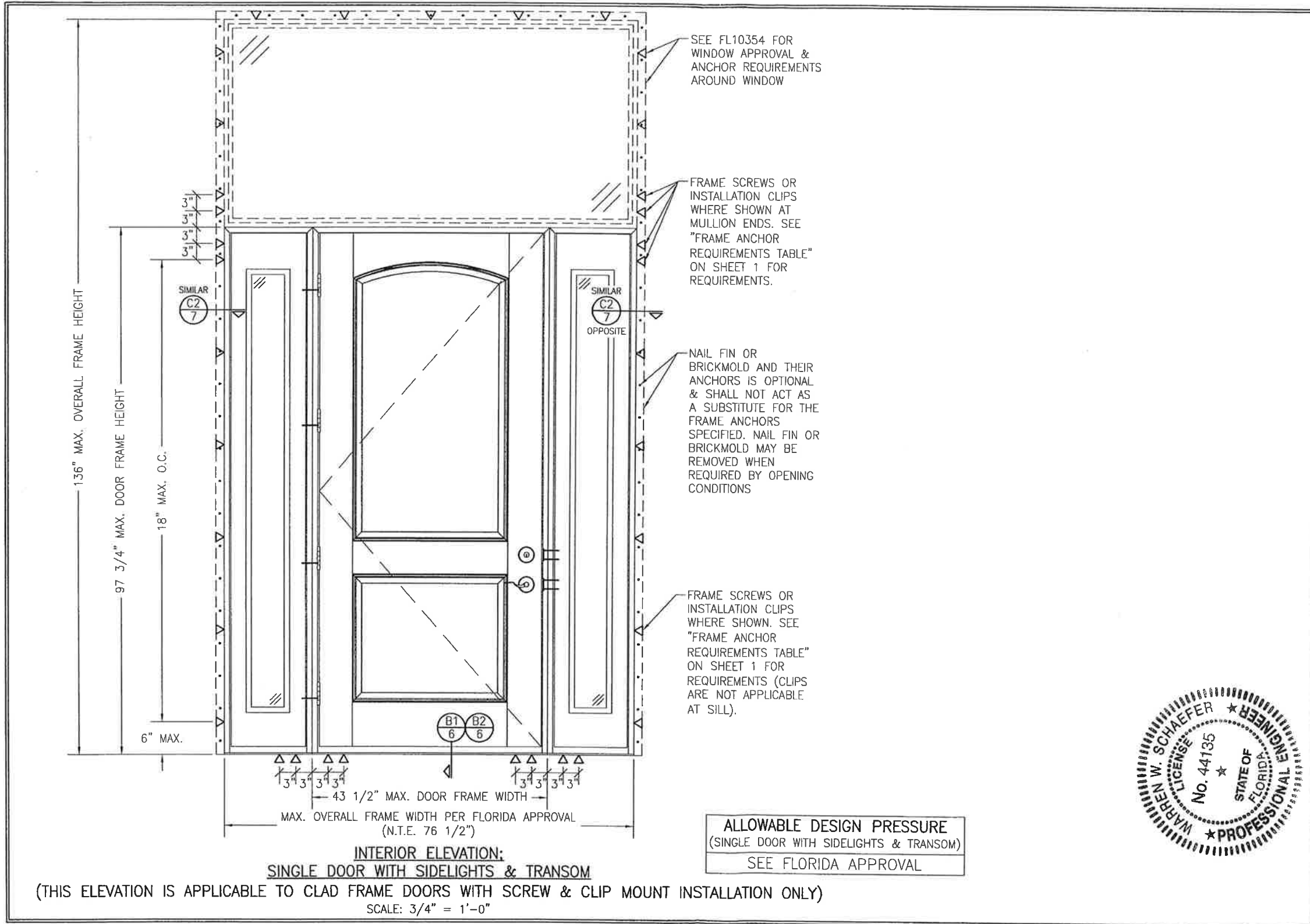

SEE FL10354 FOR WINDOW APPROVAL & ANCHOR REQUIREMENTS AROUND WINDOW

FRAME SCREWS OR INSTALLATION CLIPS WHERE SHOWN AT MULLION ENDS. SEE "FRAME ANCHOR REQUIREMENTS TABLE" ON SHEET 1 FOR REQUIREMENTS.

NAIL FIN OR BRICKMOLD AND THEIR ANCHORS IS OPTIONAL & SHALL NOT ACT AS A SUBSTITUTE FOR THE FRAME ANCHORS SPECIFIED. NAIL FIN OR BRICKMOLD MAY BE REMOVED WHEN REQUIRED BY OPENING CONDITIONS

FRAME SCREWS OR INSTALLATION CLIPS WHERE SHOWN. SEE "FRAME ANCHOR REQUIREMENTS TABLE" ON SHEET 1 FOR REQUIREMENTS (CLIPS ARE NOT APPLICABLE AT SILL).

ALLOWABLE DESIGN PRESSURE
(SINGLE DOOR WITH SIDELIGHTS & TRANSOM)
SEE FLORIDA APPROVAL

**INTERIOR ELEVATION:
SINGLE DOOR WITH SIDELIGHTS & TRANSOM**

(THIS ELEVATION IS APPLICABLE TO CLAD FRAME DOORS WITH SCREW & CLIP MOUNT INSTALLATION ONLY)

SCALE: 3/4" = 1'-0"



DRAWN BY: W.R.M.	CHECKED BY: W.W.S.
PLOT: 1-15	DATE: 09/23/11
NO.	REVISION DESCRIPTION
DATE	BY
DRAWING TITLE PELLA & ARCHITECT SERIES STEEL & FIBERGLASS PANEL IN-SWING NON-IMPACT CLAD & WOOD FRAME DOORS	
CONSULTANTS W. W. SCHAEFER ENGINEERING & CONSULTING, P.A. (CA 6809) 7480 150TH COURT NORTH PALM BEACH GARDENS, FL 33418 PHONE: 561-744-3424	
MANUFACTURER PELLA CORPORATION 102 MAIN STREET PELLA, IA 50219 641-621-1000	
CERTIFICATION APR 23 2015	WARREN W. SCHAEFER, P.E. P.E. NO. 44135
DRAWING NO. 1774	REV. B
SHEET NO. 5	OF 8

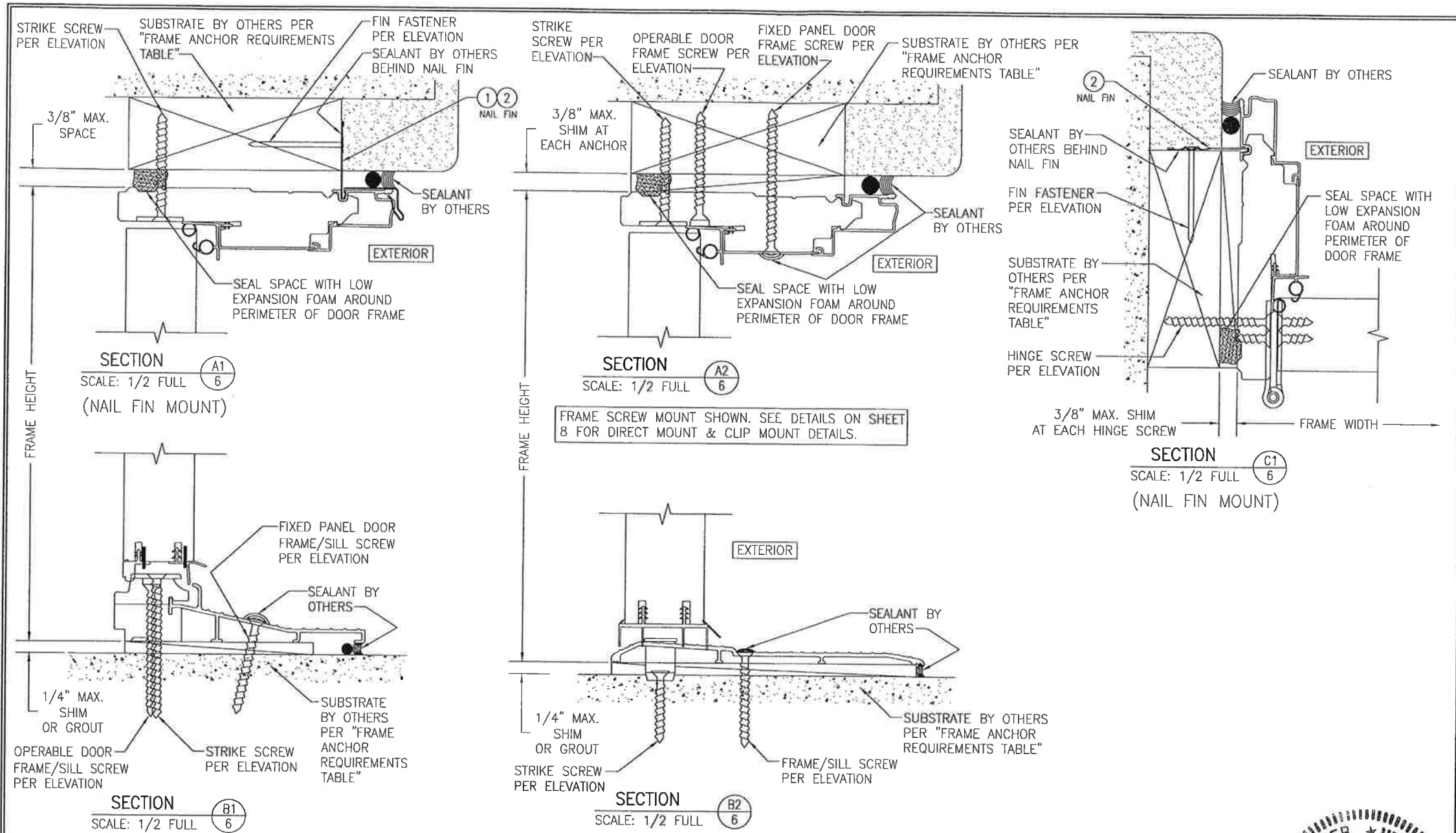

FRAME SCREW MOUNT SHOWN. SEE DETAILS ON SHEET 8 FOR DIRECT MOUNT & CLIP MOUNT DETAILS.

NAIL FIN & BRICKMOLD IS NOT SHOWN BUT MAY BE USED IN ADDITION TO ANCHORS SHOWN.

CLAD FRAME SHOWN. WOOD ONLY FRAME ALSO APPLIES.

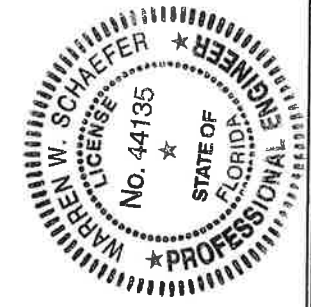

DRAWN BY: W.R.M.	CHECKED BY: W.W.S.
PLOT: 1-2	DATE: 09/23/11
NO.	REVISION DESCRIPTION
BY	DATE
DRAWING TITLE PELLA & ARCHITECT SERIES STEEL & FIBERGLASS PANEL IN-SWING NON-IMPACT CLAD & WOOD FRAME DOORS	
CONSULTANTS W. W. SCHAEFER ENGINEERING & CONSULTING, P.A. (CA 6809) 7480 150TH COURT NORTH PALM BEACH GARDENS, FL 33418 PHONE: 561-744-3424	MANUFACTURER PELLA CORPORATION 102 MAIN STREET PELLA, IA 50219 641-621-1000
CERTIFICATION APR 23 2015	WARREN W. SCHAEFER, P.E. P.E. NO. 44135
DRAWING NO. 1774	REV. B
SHEET NO. 6 OF 8	

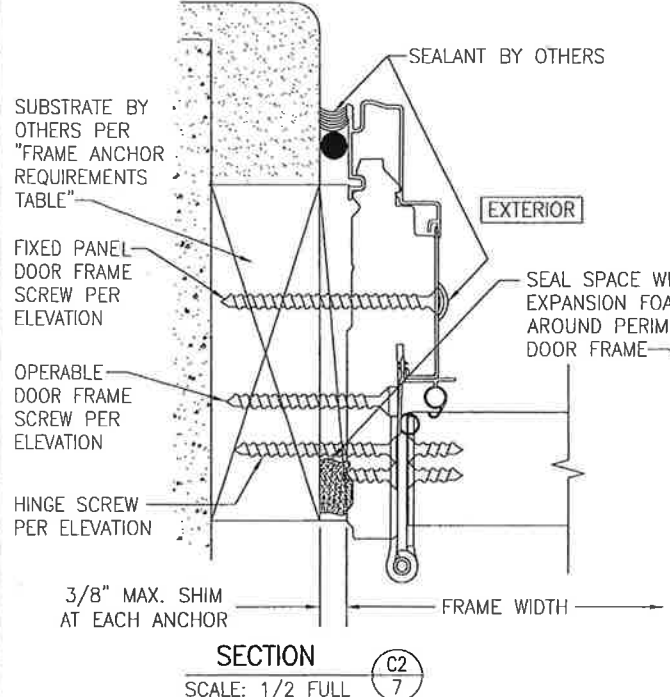

SECTION C2
SCALE: 1/2 FULL

FRAME SCREW MOUNT SHOWN. SEE DETAILS ON SHEET 8 FOR DIRECT MOUNT & CLIP MOUNT DETAILS.

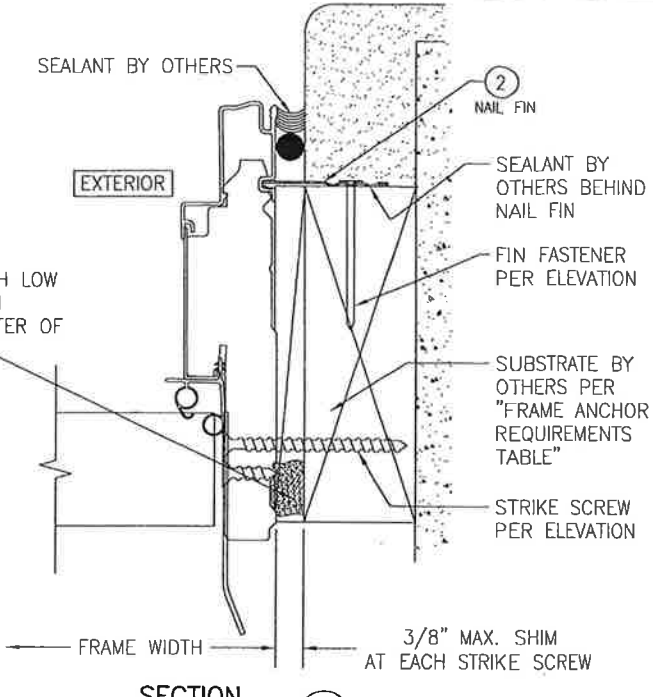

SECTION D1
SCALE: 1/2 FULL

(NAIL FIN MOUNT)

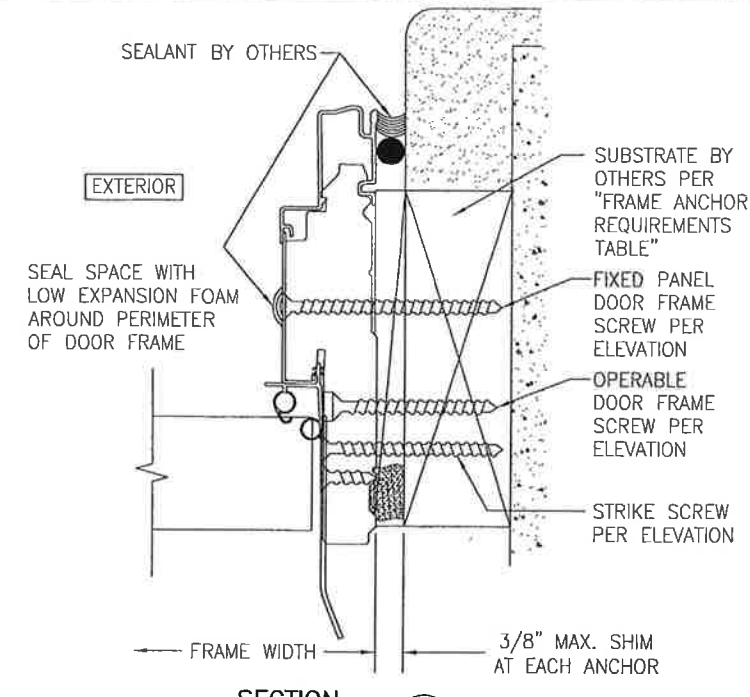

SECTION D2
SCALE: 1/2 FULL

FRAME SCREW MOUNT SHOWN. SEE DETAILS ON SHEET 8 FOR DIRECT MOUNT & CLIP MOUNT DETAILS.

NAIL FIN & BRICKMOLD IS NOT SHOWN BUT MAY BE USED IN ADDITION TO ANCHORS SHOWN.

CLAD FRAME SHOWN. WOOD ONLY FRAME ALSO APPLIES.



DRAWN BY: W.R.M.		CHECKED BY: W.W.S.	
PLOT: 1=2		DATE: 08/23/11	
DATE	BY	REVISION DESCRIPTION	NO.
DRAWING TITLE: PELLA & ARCHITECT SERIES STEEL & FIBERGLASS PANEL IN-SWING NON-IMPACT CLAD & WOOD FRAME DOORS			
CONSULTANTS: W. W. SCHAEFER ENGINEERING & CONSULTING, P.A. (CA 6809) 7480 150TH COURT NORTH PALM BEACH GARDENS, FL 33418 PHONE: 561-744-3624		PELLA CORPORATION 102 MAIN STREET PELLA, IA 50219 641-621-1000	
			
CERTIFICATION	APR 23 2015	WARREN W. SCHAEFER, P.E.	
DRAWING NO.	1774	REV.	B
SHEET NO.	7	OF	8

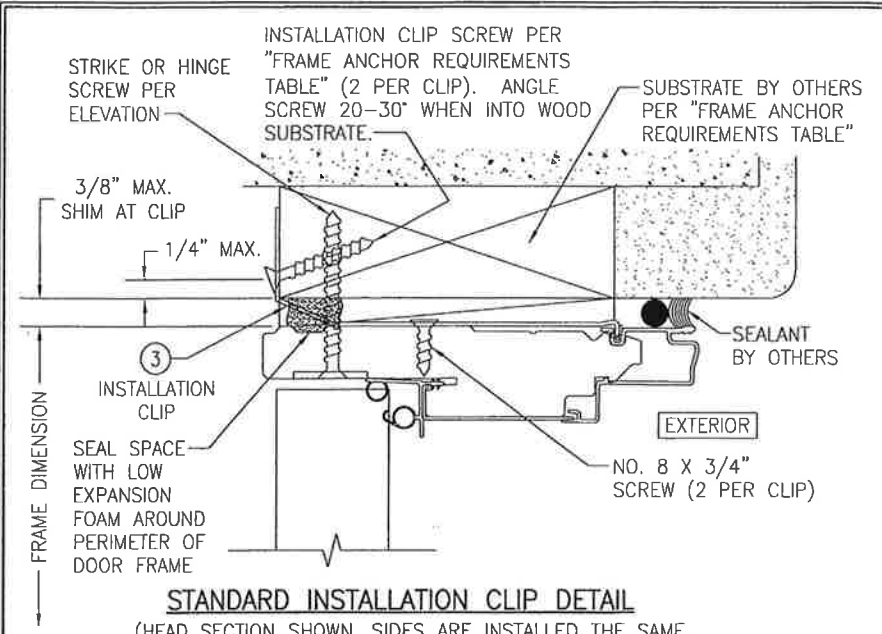

STANDARD INSTALLATION CLIP DETAIL
 (HEAD SECTION SHOWN, SIDES ARE INSTALLED THE SAME.
 INSTALLATION CLIPS DO NOT APPLY AT SILL)
 (FOR DETAIL NOT SHOWN, SEE OTHER SECTIONS)

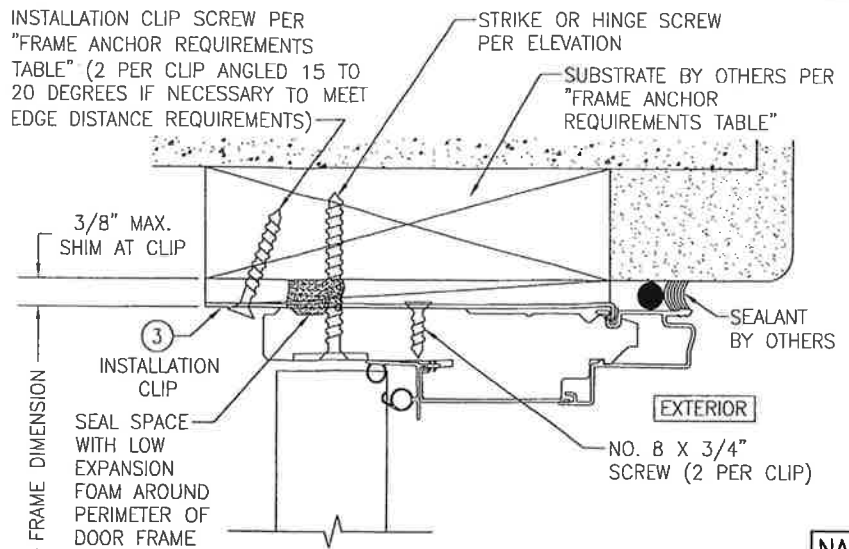

ALTERNATE INSTALLATION CLIP DETAIL
 (HEAD SECTION SHOWN, SIDES ARE INSTALLED THE SAME.
 INSTALLATION CLIPS DO NOT APPLY AT SILL)
 (FOR DETAIL NOT SHOWN, SEE OTHER SECTIONS)

NAIL FIN & BRICKMOLD IS NOT SHOWN BUT MAY BE USED IN ADDITION TO ANCHORS SHOWN.

CLAD FRAME SHOWN. WOOD ONLY FRAME ALSO APPLIES.

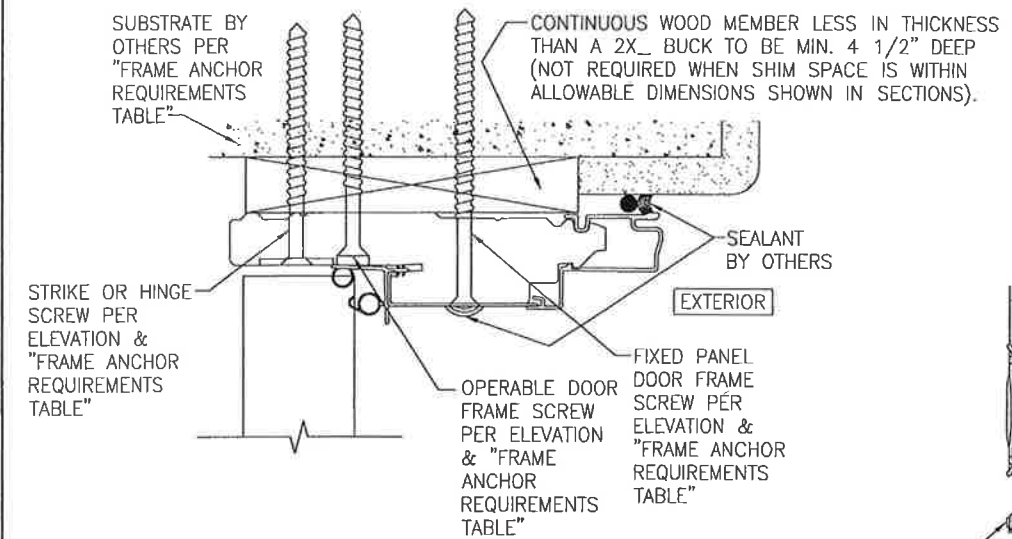

OPTIONAL DIRECT MOUNT DETAIL TO SUBSTRATE WITH SPACER
 (HEAD SECTION SHOWN; SILL & SIDES ARE INSTALLED THE SAME)
 (FOR DETAIL NOT SHOWN, SEE OTHER SECTIONS)

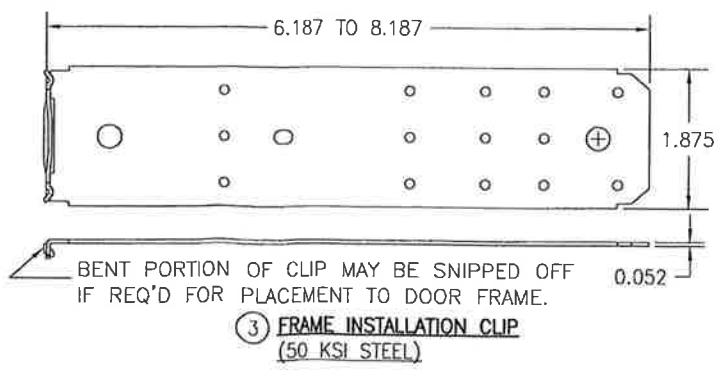
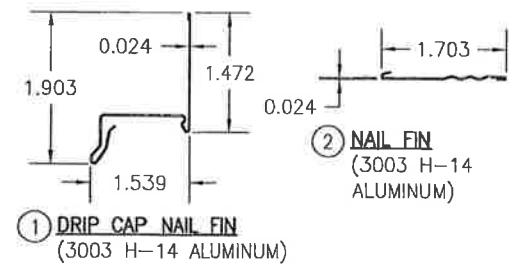

DRAWN BY:	W.R.M.	CHECKED BY:	W.W.S.
PLOT:	1-2	DATE:	09/23/11
DATE:			
BY:			
REVISION DESCRIPTION:			
NO.			
DRAWING TITLE: PELLA & ARCHITECT SERIES STEEL & FIBERGLASS PANEL IN-SWING NON-IMPACT CLAD & WOOD FRAME DOORS			
CONSULTANTS: W. W. SCHAEFER ENGINEERING & CONSULTING, P.A. (CA 6809) 7480 150TH COURT NORTH, PALM BEACH GARDENS, FL 33418 PHONE: 561-744-3424			
MANUFACTURER: PELLA CORPORATION 102 MAIN STREET, PELLA, IA 50219 641-621-1000			
CERTIFICATION:	APR 23 2015		
DRAWING NO.:	1774	REV.:	B
SHEET NO.:	8	OF	8



RICK SCOTT, GOVERNOR

JONATHAN ZACHEM, SECRETARY



STATE OF FLORIDA
DEPARTMENT OF BUSINESS AND PROFESSIONAL REGULATION
CONSTRUCTION INDUSTRY LICENSING BOARD

THE GENERAL CONTRACTOR HEREIN IS CERTIFIED UNDER THE
PROVISIONS OF CHAPTER 489, FLORIDA STATUTES

CAFARO, PETER ANTHONY III

LOWE'S HOME CENTERS, LLC
1605 CURTIS BRIDGE RD
WILKESBORO NC 28697

LICENSE NUMBER: CGC1508417

EXPIRATION DATE: AUGUST 31, 2020

Always verify licenses online at MyFloridaLicense.com



Do not alter this document in any form.

This is your license. It is unlawful for anyone other than the licensee to use this document.



Risk Management Department

**Re: Lowe's Home Centers, LLC Competency License
Florida General Contractor's License # CGC1508417, Peter Anthony Cafaro, III, Certified General Contractor.
Florida Contractor's License # CCC1328824, Peter Anthony Cafaro, III, Certified Roofing Contractor.**

Dear Sir/Madam:

This letter will confirm that Lowe's Home Centers, LLC (a wholly owned subsidiary of Lowe's Companies, Inc. (hereinafter "Lowe's")) intends to satisfy the general liability insurance requirement through a program of self-insurance. Lowe's self insures for each general liability claim in an amount up to and including \$5,000,000 which is the attachment point for Lowe's excess liability policy which is written through Steadfast Insurance Company as evidenced on our certificate of insurance. Lowe's Companies, LLC maintains reserves to support this program of self insurance based on a review (performed at least annually) by a certified casualty actuary.

Lowe's Companies, Inc. is a Fortune 50 company and operates more than 1,750 stores in the US, Canada and Mexico. Lowe's sales in 2014 were in excess of \$53 billion. You may access Lowe's financial information at www.lowes.com.

Please feel free to contact me at (704) 758-3123 or Shonna.M.Splain@Lowes.com if you have any questions.

Very truly yours,

**Shonna Splain
Insurance & Risk Administrator
Risk Management Department**

Tax Collector Scott Randolph

Local Business Tax Receipt

Orange County, Florida

This local Business Tax Receipt is in addition to and not in lieu of any other tax required by law or municipal ordinance. Businesses are subject to regulation of zoning, health and other lawful authorities. This receipt is valid from October 1 through September 30 of receipt year. Delinquent penalty is added October 1.

1801	CERTIFIED GENERAL C	\$30.00	EXPIRES 9/30/2020	1801-0590711
1806	CERTIFIED ROOFING CO	\$30.00	2 EMPLOYEES ; 5000 BUSINESS OFFICE	2 EMPLOYEES ;



TOTAL TAX \$90.00
 PREVIOUSLY PAID \$90.00
 TOTAL DUE \$0.00

12200 LAKE UNDERHILL RD
 U - ORLANDO, 32825
 CAFARO PETER ANTHONY III-CGC1508417
 PAID: \$90.00 2004-05442084 9/19/2019

CAFARO PETER ANTHONY III-CGC1508417
 LOWES HOME CENTERS LLC
 CAFARO PETER ANTHONY III-CGC1508417
 P O BOX 781993
 ORLANDO FL 32878

This receipt is official when validated by the Tax Collector.

Orange County Code requires this local Business Tax Receipt to be displayed conspicuously at the place of business in public view. It is subject to inspection by all duly authorized officers of the County.