



# City of Belle Isle

Universal Engineering Sciences 3532 Maggie Blvd., Orlando, FL 32811  
Tel 407-581-8161 \* Fax 407-581-0313 \* [www.universallengengineering.com](http://www.universallengengineering.com)

## PERMIT CARD – PLEASE POST AT JOB SITE

THIS DOCUMENT BECOMES YOUR PERMIT WHEN PROPERLY VALIDATED

Per FBC 105.3.3: An enforcing authority may not issue a building permit for any building construction, erection, alteration, modification, repair or addition unless the permit either includes on its face or there is attached to the permit the following statement: "NOTICE: In addition to the requirements of this permit, there may be additional restrictions applicable to this property that may be found in the public records of this county, and there may be additional permits required from other governmental entities such as water management districts, state agencies, or federal agencies." The issuance of this permit does not grant permission to violate any applicable City, Orange County, State of Florida and/or Federal codes and/or ordinances. Separate permits are required for Signs, Roofing, Electrical, Gas, Plumbing and Mechanical services. This permit becomes VOID if the work authorized is not commenced within 6 months, or is suspended or abandoned for a period of 6 months after commencement. WORK SHALL BE CONSIDERED SUSPENDED IF AN APPROVED INSPECTION HAS NOT BEEN MADE WITHIN A 6 MONTH PERIOD. PERMISSION IS GRANTED TO DO THE FOLLOWING WORK ACCORDING TO THE CONDITIONS HEREON AND THE APPROVED PLANS AND SPECIFICATIONS. SUBJECT TO COMPLIANCE WITH THE ORDINANCES OF THE CITY OF BELLE ISLE, FLORIDA.

**Scope of Work:** Building – Roof for boat dock

**Comments:** None

**Project Information**

**Address:** 3543 Cullen Lake Shore Dr. Belle Isle  
**Parcel ID:** 17-23-30-4391-20-850  
**Property Owner:** Yarbrough, Ralph and Flora  
**Phone Number:** 407-448-2234  
\*\*\*\*\*  
**Company Name:** Cardell Construction LLC  
**Contractor Name:** Tisdell, Jason  
**License Number:** CGC1515577  
**Address:** 1115 E Livingston Street, Orlando, FL 32803  
**Phone Number:** 407-947-9353

**Permit Number: 2014-12-015**

**Date of Application: 12/13/2013**

**Date Permit Issued: 12/16/2013**

**WARNING TO OWNER:** "YOUR FAILURE TO RECORD A NOTICE OF COMMENCEMENT MAY RESULT IN YOU PAYING TWICE FOR IMPROVEMENTS TO YOUR PROPERTY. IF YOU INTEND TO OBTAIN FINANCING, CONSULT WITH YOUR LENDER OR AN ATTORNEY BEFORE RECORDING YOUR NOTICE OF COMMENCEMENT." ON THE JOB INSPECTION(S) MUST BE MADE BEFORE PROCEEDING WITH SUBSEQUENT WORK. THIS CARD MUST BE DISPLAYED OUTSIDE AND BE PROTECTED FROM THE WEATHER WHILE BEING VISIBLE FROM THE STREET UNTIL THE FINAL INSPECTIONS HAVE BEEN APPROVED.

### BUILDING FEATURES

**IMPACT FEES**

School \$  
Traffic \$

**ZONING FEES**

Zoning Fee \$30.00

**UNIVERSAL ENG - BUILDING FEES**

Cert of Occ \$  
Demo \$  
Building \$  
Fence \$  
Driveway \$  
Shed \$  
Window(s) \$  
Door(s) \$  
PrePower \$  
Electrical \$  
Temp Pole \$  
Plumbing \$  
Mechanical \$  
Gas \$  
Roofing \$52.50  
Boat Dock \$  
Screen Enci \$  
Swimming Pool \$  
Sign \$

**SURCHARGE FEES**

Surcharge Fee \$2.00  
Surcharge Fee \$2.00

**TOTAL FEES \$86.50**

**Date Paid**

**CC or Check #**

**Amount Paid**

The person accepting this permit shall conform to the terms of the application on file and construction shall conform to the requirements of the Florida Building Code (FS 553).

**BUILDING INSPECTOR USE ONLY**

**IF APPLICABLE:**

Have Zoning Approval Conditions Been Met? YES NO Have Stormwater Approval Conditions

Been Met? YES NO Silt fencing in place? YES NO Turbidity Barrier in place? YES NO

BUILDING

1<sup>st</sup> \_\_\_\_\_ (Footing/Foundation)

Survey specific foundation plan must be onsite before slab pour. Approved Plan on Site? \_\_\_\_\_

2<sup>nd</sup> \_\_\_\_\_ (Slab)

3<sup>rd</sup> \_\_\_\_\_ (Lintel)(Wall Reinforcing on Masonry Building)

4<sup>th</sup> \_\_\_\_\_ (Exterior Framing)(Roof/Wall Sheathing)

5<sup>th</sup> \_\_\_\_\_ (Framing) (To be made after Plumbing/Mechanical/  
Electrical Rough-Ins & Windows/Doors Installed)

6<sup>th</sup> \_\_\_\_\_ (Insulation to be Made After Roof Installed)

7<sup>th</sup> \_\_\_\_\_ (Drywall)

8<sup>th</sup> \_\_\_\_\_ (Sidewalk/Driveway)

9<sup>th</sup> \_\_\_\_\_ (Other)

10<sup>th</sup> \_\_\_\_\_ (Final – After MEP and Other Applicable Finals)

ROOFING

1<sup>st</sup> ROOFING Deck Nailing/Dry-in/Flashing \_\_\_\_\_

2<sup>nd</sup> ROOFING Covering In-Progress \_\_\_\_\_

3<sup>rd</sup> ROOFING Covering Final \_\_\_\_\_

PLUMBING (Pool-Piping, Solar, Irrigation, Water Treatment Equip, Etc...)

1<sup>st</sup> \_\_\_\_\_ (Underground) 2<sup>nd</sup> \_\_\_\_\_ (Sewer)

3<sup>rd</sup> \_\_\_\_\_ (Rough-In/Tub Set) 4<sup>th</sup> \_\_\_\_\_ (Final)

**CHECK APPROPRIATE BOX**

GAS \_\_\_ Natural \_\_\_ LP  MECHANICAL  ELECTRICAL  LOW VOLTAGE

1<sup>st</sup> \_\_\_\_\_ (Rough-In) 2<sup>nd</sup> \_\_\_\_\_ (Final)

Inspection requests are to be emailed to [BidScheduling@UniversalEngineering.com](mailto:BidScheduling@UniversalEngineering.com); a confirmation email will be sent back to you upon scheduling. Next-Day Inspection requests must be made by 1pm. Please include the following in your request: Permit #, project address, type of inspection, date of the requested inspection, a contact name & a contact phone number. AM or PM may be requested but cannot be guaranteed.

For a copy of your permit, or to check inspection results, please visit <https://universallengengineering.sharefile.com/ff0946dc4-832d-44bd-9809-ecf32f9e2e63>  
login ID = [cobi@universallengengineering.com](mailto:cobi@universallengengineering.com) password = [universal13](https://universallengengineering.com/ff0946dc4-832d-44bd-9809-ecf32f9e2e63)

PROJECT NUMBER 0115.1300813.0000

TASK NUMBER 02

CITY OF BELLE ISLE  
Permit Application Review Sheet

|                            |  |
|----------------------------|--|
| Permit Number              | 2014-12-015                                    |
| Property Owner             | Yauborough                                     |
| Address                    | 3543 Cullen Lake Shore Dr                      |
| Nature of Improvement      | Pool   |
| Received Application       | 12-13-13                                       |
| Sent for Stormwater Review |  |
| Stormwater Approved        |  |
| Sent for Zoning Review     |  |
| Zoning Approved            |  |
| Applied for Variance       |  |
| Variance Approved          |  |
| Sent to BO for Review      | 12-13-13                                       |
| Building Official Approved | 12-16-13                                       |
| Comments                   |  |
| 1.                         | 12-16-13 eq hold until Bldg permit is approved |
| 2.                         |  |
| 3.                         |  |
| 4.                         |  |
| 5.                         |  |
| 6.                         |  |
| 7.                         |  |
| 8.                         |  |
| 9.                         |  |
| 10.                        |  |
| 11.                        |  |
| 12.                        |  |



**City of Belle Isle**  
 Universal Engineering Sciences 3532 Maggie Blvd., Orlando, FL 32811  
 Tel 407-581-8161 \* Fax 407-581-0313 \* [www.universalengineering.com](http://www.universalengineering.com)

**Received**  
12-13-13

**APPLICATION FOR ROOFING PERMIT**

**WARNING TO OWNER:** YOUR FAILURE TO RECORD A NOTICE OF COMMENCEMENT MAY RESULT IN YOUR PAYING TWICE FOR IMPROVEMENTS TO YOUR PROPERTY. A NOTICE OF COMMENCEMENT MUST BE RECORDED AND POSTED ON THE JOB SITE BEFORE THE FIRST INSPECTION. IF YOU INTEND TO OBTAIN FINANCING, CONSULT WITH YOUR LENDER OR AN ATTORNEY BEFORE RECORDING YOUR NOTICE OF COMMENCEMENT.

DATE OF APPLICATION: 12/12/13 ROOF PERMIT NUMBER 2014-12-015  
 PLEASE PRINT. The undersigned hereby applies for a permit to make installations as indicated below.

Project Address 3543 Cullen Lake Shore Drive Belle Isle, FL  32809  32812

Property Owner Ralph Yarbrough Phone 407-448-2234

Property Owner's Mailing Address 3543 Cullen Lake Shore Drive City Belle Isle

State FL Zip Code 32812 Parcel Id Number: 17-23-30-4391-20-850

REQUIRED! To obtain this information, please visit <http://www.ocpafl.org/Searches/ParcelSearch.aspx>

Class of Building: Old  New  Type of Building: Residential  Commercial  Other   
 Type of Work: New Roof  ReRoof

- **REQUIRED!** Florida Product Approval Screen Printout from [www.floridabuilding.org](http://www.floridabuilding.org) showing the Code Version
- **REQUIRED!** Florida Product Approval Installation Instructions from [www.floridabuilding.org](http://www.floridabuilding.org) (not the manufacturer instructions)
- **REQUIRED!** Copies of your General Liability & Worker's Comp Insurance Certificate & State and Local Licenses

Please indicate the nature of work by completing the information below:

Roof Square Footage: 275 Number of Stories: 1 Job Valuation: \$ 1,800.00

Type: Asphalt Shingles  Metal  Modified Bitumen  Other: \_\_\_\_\_

I hereby certify that the above is true and correct to the best of my knowledge and make Application for Permit as outlined above, and if same is granted I agree to conform to all Florida Building Code Regulations and City Ordinances regulating same and in accordance with plans submitted. The issuance of this permit does not grant permission to violate any applicable Town and/or State of Florida codes and/or ordinances.

LICENSE HOLDER SIGNATURE \_\_\_\_\_ LICENSE # CL151557

LICENSE HOLDER NAME JASON FISDELL COMPANY NAME CARDELL CONSTRUCTION, LLC

Street Address 1115 East Livingston Street

City ORLANDO State FL Zip Code 32803 Phone Number 407-947-9353

Email Address JASON@CARDELLCONSTRUCTIONLLC.COM

Zoning Fee \$ 30.00  
 Permit Fee \$ 52.50  
 3% Florida Surcharge \$ 4.00  
 Total Permit Fee \$ 86.50

Building Official: Mark Perry Date 12-16-2013

NOTE: The Building Permit Number is required if the Roof Installation is associated with any construction or alteration where a Building Permit has been issued.

Building Permit Number 2014-12-014



**City of Belle Isle**  
Universal Engineering Sciences 3532 Maggie Blvd., Orlando, FL 32811  
Tel 407-581-8161 \* Fax 407-581-0313 \* [www.universalengineering.com](http://www.universalengineering.com)

## Product Approval Form

DATE: 12/12/13

PERMIT # \_\_\_\_\_

PROJECT ADDRESS \_\_\_\_\_ Belle Isle, FL  32809  32812

As required by Florida Statute 553.842 and Florida Administrative Code 9B-72m, please provide the information and approval numbers of the building components listed below if they will be utilized on the building or structure. FL Approved products are listed online at [www.floridabuilding.org](http://www.floridabuilding.org) or can be obtained from the local product supplier. The following information must be turned in with permit application and available onsite for inspections:

1. This Product Approval Cover Sheet
2. Internet screen from [FloridaBuilding.org](http://FloridaBuilding.org) showing PA#, approval and code edition stamped
3. Manufacturer's *installation* details from [FloridaBuilding.org](http://FloridaBuilding.org) and requirements for each product stamped

| Product Type                 | Manufacturer                   | Model/Series                 | FL Product Approval # | Product Type     | Manufacturer     | Model/Series | FL Product Approval # |              |                  |            |
|------------------------------|--------------------------------|------------------------------|-----------------------|------------------|------------------|--------------|-----------------------|--------------|------------------|------------|
| <b>EXTERIOR DOORS</b>        |                                |                              |                       |                  |                  |              |                       |              |                  |            |
| Swinging                     |                                |                              |                       | Sliding          | WALL PANELS      |              |                       |              |                  |            |
| Sliding                      | /                              |                              |                       | Soffits          |                  |              |                       |              |                  |            |
| Sectional/Rollup             |                                |                              |                       | Storefront       |                  |              |                       |              |                  |            |
| Other                        |                                |                              |                       | Glass Block      |                  |              |                       |              |                  |            |
| <b>WINDOWS</b>               |                                |                              |                       |                  |                  |              |                       |              |                  |            |
| Single/Dbl Hung              | /                              |                              |                       | Other            | ROOFING PRODUCTS |              |                       |              |                  |            |
| Horizontal Slider            |                                |                              |                       | Asphalt Shingles |                  |              |                       | Certain Tech | Asphalt Shingles | FL 5444-R5 |
| Casement                     |                                |                              |                       | Non Struct Metal |                  |              |                       |              |                  |            |
| Fixed                        |                                |                              |                       | Roofing Tiles    |                  |              |                       |              |                  |            |
| Mullion                      |                                |                              |                       | Single Ply Roof  |                  |              |                       |              |                  |            |
| Skylights                    |                                |                              |                       | Other            |                  |              |                       |              |                  |            |
| Other                        | /                              |                              |                       | <b>OTHER</b>     |                  |              |                       |              |                  |            |
| <b>STRUCTURAL COMPONENTS</b> |                                |                              |                       |                  |                  |              |                       |              |                  |            |
| Wood Connectors              |                                |                              |                       | /                |                  |              | OTHER                 |              |                  |            |
| Wood Anchors                 |                                |                              |                       |                  |                  |              |                       |              |                  |            |
| Truss Plates                 |                                |                              |                       |                  |                  |              |                       |              |                  |            |
| Insulation Forms             |                                |                              |                       |                  |                  |              |                       |              |                  |            |
| Lintels                      |                                |                              |                       |                  |                  |              |                       |              |                  |            |
| Other                        |                                |                              |                       |                  |                  |              |                       |              |                  |            |
|                              | Universal Engineering Sciences | Reviewed for Code Compliance |                       |                  |                  |              |                       |              |                  |            |

It is the applicant's responsibility to verify that specific products have been installed in accordance with their limitations and with the minimum required design pressures for the structure. Specific compliance will be verified during field inspections.

Applicant Signature \_\_\_\_\_

Date 12/12/13





BCIS Home | Log In | User Registration | Hot Topics | Submit Surcharge | Stats & Facts | Publications | BCIS Staff | BCIS Site Map | Links | Search

**Product Approval**  
USER: Public User



[Product Approval Menu](#) > [Product or Application Search](#) > [Application List](#) > [Application Detail](#)

FL # **FL5444-R5**  
 Application Type **Editorial Change**  
 Code Version **2010**  
 Application Status **Approved**  
 Comments  
 Archived

Product Manufacturer  
 Address/Phone/Email  
**CertainTeed Corporation-Roofing**  
 PO Box 1100  
 1400 Union Meeting Rd  
 Blue Bell, PA 19422  
 (215) 274-2350  
 Steven.T.Lawrey@saint-gobain.com

Authorized Signature  
 Steven Lawrey  
 Steven.T.Lawrey@saint-gobain.com

Technical Representative  
 Address/Phone/Email  
 Steven Lawrey  
 1400 Union Meeting Road  
 Blue Bell, PA 19422  
 (215) 274-2425  
 Steven.T.Lawrey@saint-gobain.com



Quality Assurance Representative  
 Address/Phone/Email

Category  
 Subcategory  
 Roofing  
 Asphalt Shingles

Compliance Method  
 Evaluation Report from a Florida Registered Architect or a Licensed Florida Professional Engineer  
 Evaluation Report - Hardcopy Received

Florida Engineer or Architect Name who developed the Evaluation Report  
 Florida License  
 Quality Assurance Entity  
 Quality Assurance Contract Expiration Date  
 Validated By  
 Robert Nieminen  
 PE-59166  
 UL LLC  
 02/13/2016  
 John W. Knezevich, PE  
 Validation Checklist - Hardcopy Received

Certificate of Independence  
[FL5444\\_R5\\_COI\\_Trinity\\_ERD\\_CI - Nieminen.pdf](#)

Referenced Standard and Year (of Standard)  
**Standard**  
 ASTM D3161, Class F  
 ASTM D3462  
 ASTM D7158, Class H  
**Year**  
 2006  
 2007  
 2007

Equivalence of Product Standards  
 Certified By

Sections from the Code

Product Approval Method

Method 1 Option D

Date Submitted

02/14/2013

Date Validated

02/20/2013

Date Pending FBC Approval

02/28/2013

Date Approved

04/09/2013

**Summary of Products**

| FL #   | Model, Number or Name                | Description   |
|--|--------------------------------------|---|
| 5444.1   | CertainTeed Asphalt Roofing Shingles | 3-tab, laminated, architectural and 4-tab asphalt roof shingles |
| <p><b>Limits of Use</b><br/>                     Approved for use in HVHZ: No<br/>                     Approved for use outside HVHZ: Yes<br/>                     Impact Resistant: N/A<br/>                     Design Pressure: N/A<br/>                     Other: Refer to ER Section 5 for Limits of Use</p> <p><b>Installation Instructions</b><br/> <a href="#">FL5444_R5_IL_er02202013FINAL_CERTAINTCEED_Ashphalt Shingle_FL5444-R5.pdf</a></p> <p>Verified By: Robert Nieminen, PE PE-59166<br/>                     Created by Independent Third Party: Yes</p> <p><b>Evaluation Reports</b><br/> <a href="#">EL5444_R5_AE_er02202013FINAL_CERTAINTCEED_Ashphalt Shingle_FL5444-R5.pdf</a><br/>                     Created by Independent Third Party: Yes</p> |                                      |   |

[Back](#)

[Next](#)

Contact Us :: 1940 North Monroe Street, Tallahassee FL 32399 Phone: 850-487-1824

The State of Florida is an AA/EEO employer. Copyright 2007-2013 State of Florida. :: Privacy Statement :: Accessibility Statement :: Refund Statement

Under Florida law, email addresses are public records. If you do not want your e-mail address released in response to a public-records request, do not send electronic mail to this entity. Instead, contact the office by phone or by traditional mail. If you have any questions, please contact 850.487.1395. \*Pursuant to Section 455.275(1), Florida Statutes, effective October 1, 2012, licensees licensed under Chapter 455, F.S. must provide the Department with an email address if they have one. The emails provided may be used for official communication with the licensee. However email addresses are public record. If you do not wish to supply a personal address, please provide the Department with an email address which can be made available to the public. To determine if you are a licensee under Chapter 455, F.S., please click [here](#).

**Product Approval Accepts:**





EXTERIOR RESEARCH & DESIGN, LLC.  
Certificate of Authorization #9503  
353 CHRISTIAN STREET, UNIT #13  
OXFORD, CT 06478  
PHONE: (203) 262-9245  
FAX: (203) 262-9243

## EVALUATION REPORT

CertainTeed Corporation  
1400 Union Meeting Road  
Blue Bell, PA 19422

Evaluation Report 3532.09.05-R5  
FL5444-R5  
Date of Issuance: 09/22/2005  
Revision 5: 02/20/2013

### SCOPE:

This Evaluation Report is issued under Rule 9N-3 and the applicable rules and regulations governing the use of construction materials in the State of Florida. The documentation submitted has been reviewed by Robert Nieminen, P.E. for use of the product under the Florida Building Code and Florida Building Code, Residential Volume. The products described herein have been designed to comply with the 2010 Florida Building Code.

### DESCRIPTION: CertainTeed Asphalt Roofing Shingles.

**LABELING:** Each unit shall bear labeling in accordance with the requirements of the Accredited Quality Assurance Agency noted herein.

**CONTINUED COMPLIANCE:** This Evaluation Report is valid until such time as the named product(s) changes, the referenced Quality Assurance documentation changes, or provisions of the Code that relate to the product change. Acceptance of this Evaluation Report by the named client constitutes agreement to notify Robert Nieminen, P.E. if the product changes or the referenced Quality Assurance documentation changes. Trinity|ERD requires a complete review of this Evaluation Report relative to updated Code requirements with each Code Cycle.

**ADVERTISEMENT:** The Evaluation Report number preceded by the words "Trinity|ERD Evaluated" may be displayed in advertising literature. If any portion of the Evaluation Report is displayed, then it shall be done in its entirety.

**INSPECTION:** Upon request, a copy of this entire Evaluation Report shall be provided to the user by the manufacturer or its distributors and shall be available for inspection at the job site at the request of the Building Official.

This Evaluation Report consists of pages 1 through 10.

### Prepared by:

**Robert J.M. Nieminen, P.E.**  
Florida Registration No. 59166, Florida DCA ANE1983

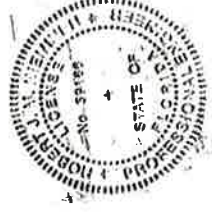

The facsimile seal appearing was authorized by Robert Nieminen, P.E. on 02/20/2013. This does not serve as an electronically signed document. Signed, sealed hardcopies have been transmitted to the Product Approval Administrator and to the named client.

### CERTIFICATION OF INDEPENDENCE:

1. Trinity|ERD does not have, nor does it intend to acquire or will it acquire, a financial interest in any company manufacturing or distributing products it evaluates.
2. Trinity|ERD is not owned, operated or controlled by any company manufacturing or distributing products it evaluates.
3. Robert Nieminen, P.E. does not have nor will acquire, a financial interest in any company manufacturing or distributing products for which the evaluation reports are being issued.
4. Robert Nieminen, P.E. does not have, nor will acquire, a financial interest in any other entity involved in the approval process of the product.



**ROOFING SYSTEMS EVALUATION:**
**1. SCOPE:**

**Product Category:** Roofing  
**Sub-Category:** Asphalt Shingles

**Compliance Statement:** CertainTeed Asphalt Roofing Shingles, as produced by CertainTeed Corporation, have demonstrated compliance with the following sections of the Florida Building Code and Florida Building Code, Residential Volume through testing in accordance with the following Standards. Compliance is subject to the Installation Requirements and Limitations / Conditions of Use set forth herein.

**2. STANDARDS:**

| <b>Section</b>         | <b>Property</b>     | <b>Standard</b>     | <b>Year</b> |
|------------------------|---------------------|---------------------|-------------|
| 1507.2.5, R905.2.4     | Physical Properties | ASTM D3462          | 2007        |
| 1507.2.7.1, R905.2.6.1 | Wind Resistance     | ASTM D3161, Class F | 2006        |
| 1507.2.7.1, R905.2.6.1 | Wind Resistance     | ASTM D7158, Class H | 2007        |

**3. REFERENCES:**

| <b>Entity</b>     | <b>Examination</b> | <b>Reference</b>     | <b>Date</b>     |
|-------------------|--------------------|----------------------|-----------------|
| UL (TST 1740)     | ASTM D3161         | 94NK9632             | 05/15/1998      |
| UL (TST 1740)     | ASTM D3161         | 99NK26506            | 11/23/1999      |
| UL (TST 1740)     | ASTM D3161         | 03CA12702            | 05/27/2003      |
| UL (TST 1740)     | ASTM D3161         | 03CA12702            | 06/16/2003      |
| UL (TST 1740)     | ASTM D3161         | 03NK29847            | 10/03/2003      |
| UL (TST 1740)     | ASTM D3161         | 04CA11329            | 05/24/2004      |
| UL (TST 1740)     | ASTM D3161         | 04CA32986            | 12/03/2004      |
| UL (TST 1740)     | ASTM D3161         | 05NK07049            | 04/15/2005      |
| UL (TST 1740)     | ASTM D3161         | 05NK16778            | 05/12/2005      |
| UL (TST 1740)     | ASTM D3161         | 05CA16778            | 05/12/2005      |
| UL (TST 1740)     | ASTM D3161         | 05NK14836            | 05/22/2005      |
| UL (TST 1740)     | ASTM D3161         | 05NK22800            | 06/22/2005      |
| UL (TST 1740)     | ASTM D3462         | R684                 | 09/21/2005      |
| UL (TST 1740)     | ASTM D7158         | 05NK08037            | 06/28/2006      |
| UL (TST 1740)     | ASTM D3161 & D3462 | 09CA28873            | 07/23/2009      |
| UL (TST 1740)     | ASTM D3462         | 10CA41303            | 10/07/2010      |
| UL (TST 1740)     | ASTM D3161         | 10CA41303            | 10/08/2010      |
| UL (TST 1740)     | ASTM D7158         | 10CA41303            | 10/27/2010      |
| UL (TST 1740)     | ASTM D3161 & D3462 | 10CA44960            | 11/11/2010      |
| UL LLC (QUA 9625) | Quality Control    | Service Confirmation | Exp. 02/13/2016 |



**4. PRODUCT DESCRIPTION:**

- 4.1 CT20™, XT™ 25 and XT™ 30 are fiberglass reinforced, 3-tab asphalt roof shingles.
- 4.2 Carriage House Shangle®, Centennial Slate™, Grand Manor Shangle®, Landmark™, Landmark™ Pro (formerly Landmark™ Plus), Landmark™ Premium, Landmark™ TL and Landmark™ Solaris are fiberglass reinforced, laminated asphalt roof shingles.
- 4.3 Presidential Shake™ and Presidential Shake TL™ are fiberglass reinforced, architectural asphalt roof shingles.
- 4.4 Hatteras™ and Highland Slate™ are fiberglass reinforced, 4-tab asphalt roof shingles.
- 4.5 Presidential Accessory, Accessory for Hatteras, Shangle Ridge™, Shadow Ridge™ and Cedar Crest™ are fiberglass reinforced accessory shingles for hip and ridge installation.
- 4.6 Any of the above listed shingles may be produced in AR (algae resistant) versions.

**5. LIMITATIONS:**

- 5.1 This Evaluation Report is not for use in the HVHZ
- 5.2 Fire Classification is not part of this Evaluation Report; refer to current Approved Roofing Materials Directory for fire ratings of this product.
- 5.3 Wind Classification:
  - 5.3.1 All shingles noted herein are Classified in accordance with FBC Tables 1507.2.7.1 and R905.2.6.1 to ASTM D3161, Class F and/or ASTM D7158, Class H, indicating the shingles are acceptable for us in all wind zones up to  $V_{asd} = 150$  mph ( $V_{uit} = 194$  mph). Refer to Section 6 for installation requirements to meet this wind rating.
  - 5.3.2 Presidential Accessory, Accessory for Hatteras, Shangle Ridge, Shadow Ridge and Cedar Crest hip & ridge shingles have been evaluated in accordance with ASTM D3161, Class F when BASF Sonolastic NP 1 adhesive or Henkel PL® Polyurethane Roof & Flashing Sealant, applied as specified in manufacturer's application instructions, indicating the shingles are acceptable for us in all wind zones up to  $V_{asd} = 150$  mph ( $V_{uit} = 194$  mph).
  - 5.3.3 Classification by ASTM D7158 applies to exposure category B or C and a building height of 60 feet or less. Calculations by a qualified design professional are required for conditions outside these limitations. Contact the shingle manufacturer for data specific to each shingle.
- 5.4 All products in the roof assembly shall have quality assurance audits in accordance with the Florida Building Code and F.A.C. Rule 9N-3.

**6. INSTALLATION:**

- 6.1 Roof deck, slope, underlayment and fasteners shall comply with FBC 1507.2 / R905.2 and the shingle manufacturer's minimum requirements.
- 6.1.1 Underlayment shall be acceptable to CertainTeed Corporation and shall hold current Florida Statewide Product Approval, or be Locally Approved per Rule 9N-3, per FBC Sections 1507.2.3, 1507.2.4 or R905.2.3.
- 6.2 Installation of asphalt shingles shall comply with the manufacturer's current published instructions, using minimum four (4) nails per shingle in accordance with FBC 1507.2.7 or Section R905.2.6 and the minimum requirements herein.
- 6.2.1 Fasteners shall be in accordance with manufacturer's published requirements, but not less than FBC 1507.2.6 or R905.2.5. Staples are not permitted.
- 6.2.2 Where the roof slope exceeds 21 units vertical in 12 units horizontal, use the "Steep Slope" directions.
- 6.3 CertainTeed asphalt shingles are acceptable for use in reroof (tear-off) or recover applications, subject to the limitations set forth in FBC Section 1510 and CertainTeed published installation instructions.

**6.3.1 CI20™, XI™ 25, and XI™ 30:**

**LOW AND STANDARD SLOPE**

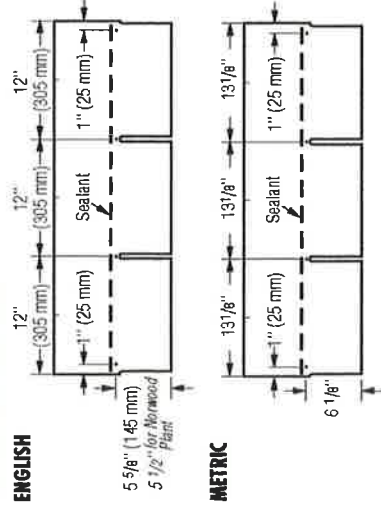

Figure 11-3: Use fewer nails for every full shingle.

**6.3.1.1 Hip & Ridge: Cut Shingles**

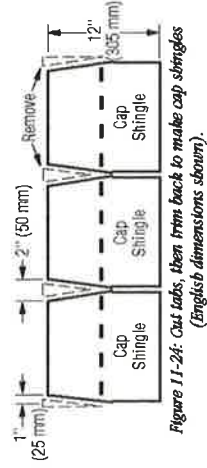

Figure 11-24: Cut tabs, then trim back to make cap shingles (English dimensions shown).

**STEEP SLOPE**

Use four nails and six spots of asphalt roofing cement\* for every full shingle (Figure 11-4). Asphalt roofing cement meeting ASTM D4586 Type II is suggested.

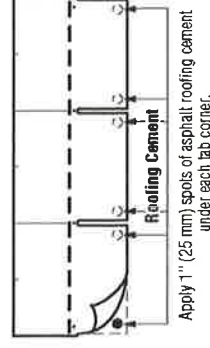

Figure 11-4: Use four nails and six spots of asphalt cement on steep slopes.

\*CAUTION: Excessive use of roofing cement can cause shingles to blister.

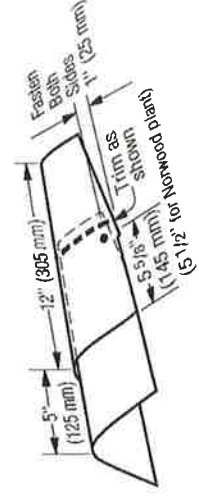

Figure 11-25: Installation of caps along the hips and ridges.

Note: For ASTM D3161 - Class F, use BASF Sonolastic NP 1 adhesive or Henkel PL® Polyurethane Roof & Flashing Sealant, in accordance with manufacturer's instructions.

6.3.2

**Carriage House Shangle®, Centennial Slate™ and Grand Manor Shangle®:**

**LOW AND STANDARD SLOPE**

Use five nails for every full Shangle.

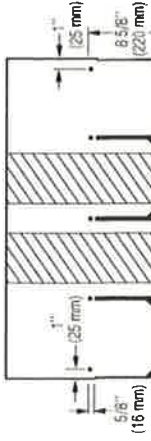

Figure 17-4: Use five nails for every full Grand Manor Shangle, Carriage House Shangle, or Centennial Slate.

**STEEP SLOPE**

Use seven nails and three spots of asphalt roofing cement for every full Grand Manor Shangle. Use five nails and three spots of asphalt roofing cement for every full Carriage House Shangle and Centennial Slate. Apply asphalt roofing cement 1" (25 mm) from edge of shingle (Figure 17-5). Asphalt roofing cement meeting ASTM D4586 Type II is suggested.

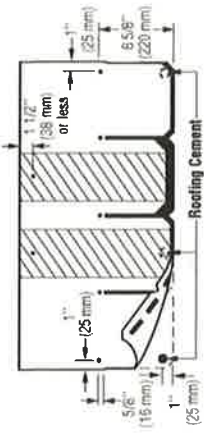

Figure 17-5: When installing Grand Manor Shangles on steep slopes, use seven nails and three spots of asphalt roofing cement.

6.3.2.1 Hip & Ridge: Shangle® Ridge

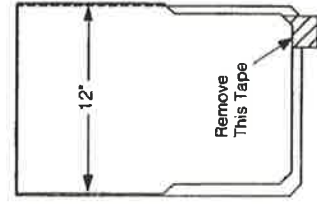

Figure 17-18: Shangle® Ridge.

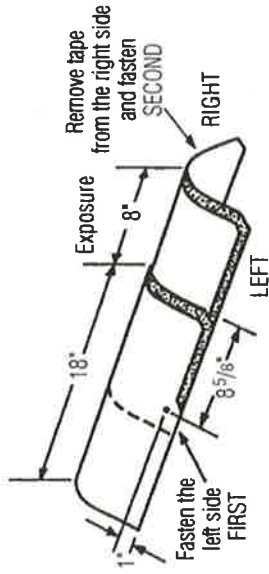

Figure 17-19: Installation of Shangle® Ridge shingles on hips and ridges.

Note: For ASTM D3161 - Class F, use BASF Sonolastic NP 1 adhesive or Henkel PL® Polyurethane Roof & Flashing Sealant in accordance with manufacturer's instructions.

### 6.3.3

#### Landmark™, Landmark™ Pro (formerly Landmark™ Plus), Landmark™ Premium, Landmark™ TL and Landmark™ Solaris:

##### LOW AND STANDARD SLOPE

##### LANDMARK TL

##### METRIC DIMENSIONS

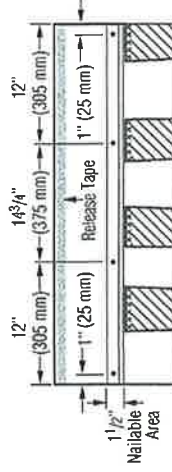

1 1/2"  
Nailable Area

##### STEEP SLOPE

Use six nails and four spots of asphalt roofing cement for every full laminated shingle. See below. Asphalt roofing cement should meet ASTM D4586 Type II. Apply 1" spots of asphalt roofing cement under each corner and at about 1.2" to 1.3" in from each edge.

##### METRIC DIMENSIONS

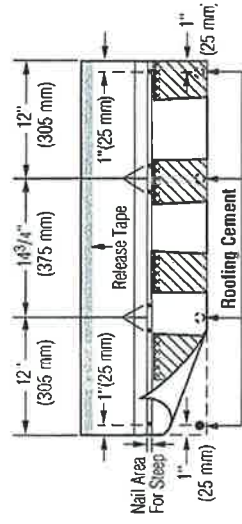

1 1/2"  
Nail Area For Steep

#### 6.3.3.1 Hip & Ridge, Option 1: Shadow Ridge™

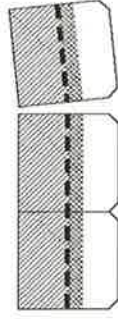
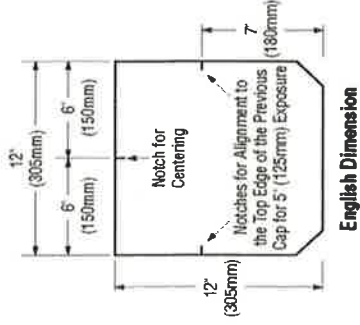
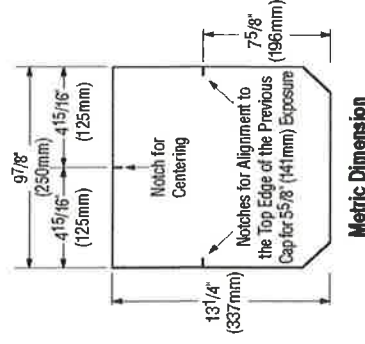

Figure 13-16: Shadow Ridge accessory shingles detach easily from three-piece units to make 72 individual cap pieces.



English Dimension



Metric Dimension

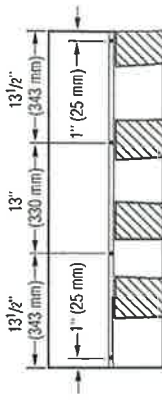

Figure 13-4: Use four units for every full shingle.

##### LANDMARK TL

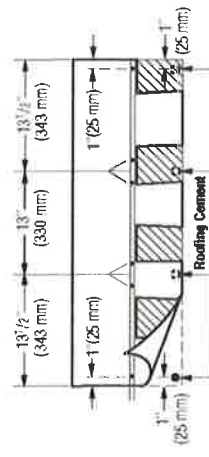

Figure 13-5: Use six nails and four spots of asphalt roofing cement on steep slopes.



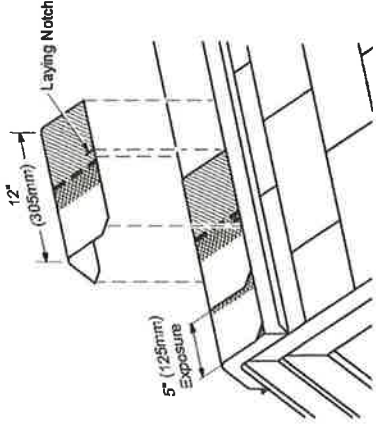
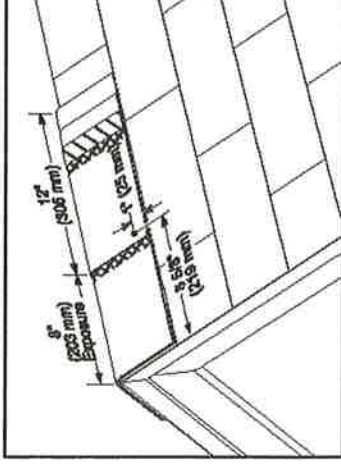

Figure 1.3-20: Use laying notches to center shingles on hips and ridges, and to locate the correct exposure.

Note: For ASTM D3161 - Class F, use BASF Sonolastic NP 1 adhesive or Henkel PL® Polyurethane Roof & Flashing Sealant in accordance with manufacturer's instructions.

### 6.3.3.2 Hip & Ridge, Option 2: Cedar Crest™

Use two fasteners per shingle. For the starter shingle, place fastener 1-inch from each side edge and about 2-inch up from the starter shingle's exposed butt edge. For each full Cedar Crest shingle, please fasteners 8-5/8-inch up from its exposed butt edge and 1-inch from each side edge.



Note: For ASTM D3161 - Class F, use BASF Sonolastic NP 1 adhesive or Henkel PL® Polyurethane Roof & Flashing Sealant to hand-seal Cedar Crest shingles. Apply NP 1 or PL adhesive from the middle of the shingle's raised overlay on the top piece and extending approximately 4-inch along the sides of the headlap along a line 3/4 to 1-inch from each side of the shingle's headlap. Immediately align and apply the overlying shingle, gently pressing tab sides into the adhesive, and install nails. To secure the other side, apply a 1-inch diameter spot of NP 1 or PL adhesive between the shingle layers.

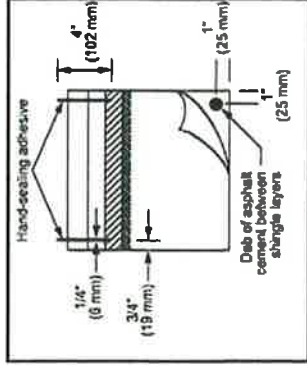

### 6.3.4 **Presidential Shake™ and Presidential Shake TL™:**

#### **LOW AND STANDARD SLOPE:**

For low and standard slopes, use five nails for each full Presidential shingle as shown below.

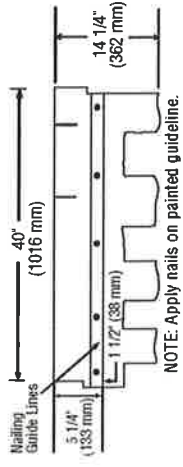

Figure 16-6: Fastening Presidential and Presidential TL Shake shingles on low and standard slopes.

#### **STEP SLOPE:**

For steep slopes, use nine nails for each full Presidential shingle and apply 1" diameter spots of asphalt roofing cement under each shingle tab. After applying 5 nails in between the nailing guide lines, apply 4 nails 1" above tab cutouts making certain tabs of overlying shingle cover nails.

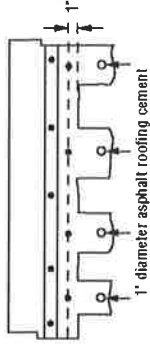

Figure 16-7: Fastening Presidential and Presidential TL Shake shingles on steep slopes.

### 6.3.4.1 Hip & Ridge, Option 1: Presidential Accessory

#### **PRESIDENTIAL ACCESSORY**

Presidential accessory shingles can be used for covering hips and ridges. Apply shingles up to the ridge (expose no more than 7" from the bottom edge of the "tooth." Fasten each accessory with two fasteners. The fasteners must be 1¾" long or longer, so they penetrate either ¾" into the deck or completely through the deck. Presidential accessory comes in two different sizes: Accessory produced in Birmingham, AL is 12" x 12"; Portland, OR produces 9 7/8" x 13 1/4" accessory.

Note: For ASTM D3161 - Class F, use BASF Sonolastic NP 1 adhesive or Henkel PL® Polyurethane Roof & Flashing Sealant in accordance with manufacturer's instructions.

### 6.3.4.2 Hip & Ridge, Option 2: Refer to instructions herein for Cedar Crest™ hip and ridge shingles.

### 6.3.5 **Hatteras™:**

#### **LOW, STANDARD AND STEP SLOPE:**



Figure 15-3: Fastening Hatteras Shingles on Low and Standard Slopes

For low and standard slopes, use five nails for each full Hatteras shingle as shown above.



Figure 15-4: Fastening Hatteras Shingles on Steep Slopes

For steep slopes, use five nails and eight spots of asphalt roofing cement for each full Hatteras shingle as shown above. Apply 1" (25mm) diameter spots of roofing cement (ASTM D 4586 Type II suggested) under each tab corner. Press shingle into place; do not expose cement.

CAUTION: Too much roofing cement can cause shingles to blister.

6.3.5.1 Hip & Ridge, Option 1: Accessory for Hatteras

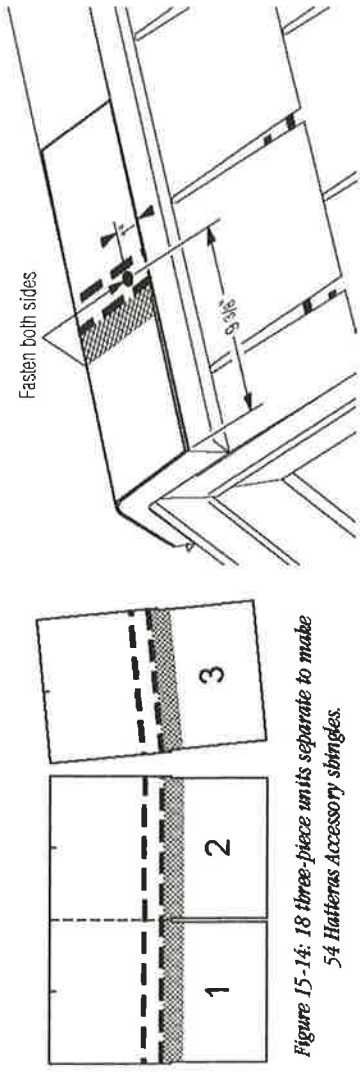

Figure 15-14: 18 three-piece units separate to make 5/4 Hatteras Accessory shingles.

Note: For ASTM D3161 - Class F, use BASF Sonolastic NP 1 adhesive or Henkel PL® Polyurethane Roof & Flashing Sealant in accordance with manufacturer's instructions.

6.3.5.2 Hip & Ridge, Option 2: Cut Hatteras Shingles

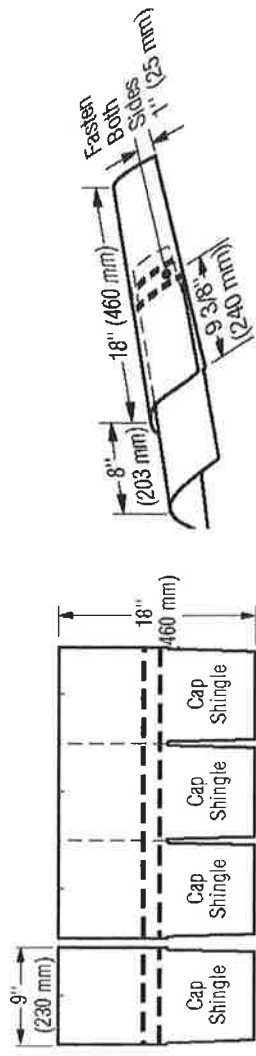

Figure 15-20: Cut Hatteras shingles to make cover cap.

Note: For ASTM D3161 - Class F, use BASF Sonolastic NP 1 adhesive or Henkel PL® Polyurethane Roof & Flashing Sealant in accordance with manufacturer's instructions.

6.3.6 **Highland Slate™:**

**LOW AND STANDARD SLOPE:**

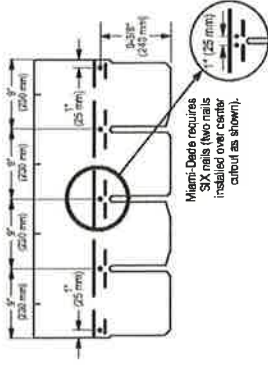

Figure 11-3: Use FIVE nails for every Highland Slate shingle.

**STEEP SLOPE:**

Use FIVE nails and EIGHT spots of asphalt roofing cement\* for each full Highland Slate shingle. For Miami-Dade, SIX nails are required. Apply 1" diameter spots of asphalt roofing cement under each lab corner. Asphalt roofing cement meeting ASTM D4586 Type II is suggested.

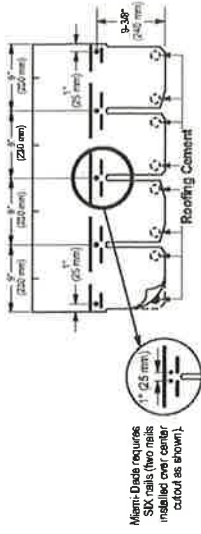

Figure 11-3a: Use FIVE nails and eight spots of asphalt roofing cement under each lab corner.

\*CAUTION: Excessive use of roofing cement can cause shingles to blister.

6.3.6.1 Hip & Ridge, Option 1: Refer to instructions herein for Cedar Crest™ or Shangle Ridge™ hip and ridge shingles.

**7. LABELING:**

- 7.1 Each unit shall bear a permanent label with the manufacturer's name, logo, city, state and logo of the Accredited Quality Assurance Agency noted herein.
- 7.2 Asphalt shingle wrappers shall indicate compliance with one of the required classifications detailed in FBC Table 1507.2.7.1 / R905.2.6.1.

**8. BUILDING PERMIT REQUIREMENTS:**

As required by the Building Official or Authority Having Jurisdiction in order to properly evaluate the installation of this product.

**9. MANUFACTURING PLANTS:**

Contact the named QA entity for information on which plants produce products covered by Florida Rule 9N-3 QA requirements.

**10. QUALITY ASSURANCE ENTITY:**

UL LLC – QUA9625; (414) 248-6409; karen.buchmann@us.ul.com

- END OF EVALUATION REPORT -





# CERTIFICATE OF LIABILITY INSURANCE

DATE (MM/DD/YYYY)  
12/13/2013

THIS CERTIFICATE IS ISSUED AS A MATTER OF INFORMATION ONLY AND CONFERS NO RIGHTS UPON THE CERTIFICATE HOLDER. THIS CERTIFICATE DOES NOT AFFIRMATIVELY OR NEGATIVELY AMEND, EXTEND OR ALTER THE COVERAGE AFFORDED BY THE POLICIES BELOW. THIS CERTIFICATE OF INSURANCE DOES NOT CONSTITUTE A CONTRACT BETWEEN THE ISSUING INSURER(S), AUTHORIZED REPRESENTATIVE OR PRODUCER, AND THE CERTIFICATE HOLDER.

**IMPORTANT:** If the certificate holder is an ADDITIONAL INSURED, the policy(ies) must be endorsed. If SUBROGATION IS WAIVED, subject to the terms and conditions of the policy, certain policies may require an endorsement. A statement on this certificate does not confer rights to the certificate holder in lieu of such endorsement(s).

|                                 |   |
|---------------------------------|---|
| PRODUCER                        | Phone: (386) 734-9642 Fax: (386) 734-6701 |
| <b>PAGE INSURANCE AGENCY</b>    |   |
| PO BOX 1209                     |   |
| 500 E NEW YORK AVE              |   |
| DELAND FL 32721-1209            |   |
| INSURED                         | Agency Lic#: R010619                      |
| <b>CARDELL CONSTRUCTION LLC</b> |   |
| 1115 E LIVINGSTON ST            |   |
| ORLANDO FL 32803                |   |
| CONTACT NAME                    | <b>Darcey Tascher</b>                     |
| PHONE (A/C, No, Ext)            | (386) 734-9642                            |
| E-MAIL                          | <b>dtascher@pageinsuranceagency.com</b>   |
| ADDRESS                         |   |
| PRODUCER CUSTOMER ID            | <b>15901</b>                              |
| INSURER A                       | <b>INSURER(S) AFFORDING COVERAGE</b>      |
| INSURER B                       | <b>Vinings Insurance Company</b>          |
| INSURER C                       |   |
| INSURER D                       |   |
| INSURER E                       |   |
| INSURER F                       |   |

**COVERAGES**      **CERTIFICATE NUMBER: 74446**      **REVISION NUMBER:**

THIS IS TO CERTIFY THAT THE POLICIES OF INSURANCE LISTED BELOW HAVE BEEN ISSUED TO THE INSURED NAMED ABOVE FOR THE POLICY PERIOD INDICATED. NOTWITHSTANDING ANY REQUIREMENT, TERM OR CONDITION OF ANY CONTRACT OR OTHER DOCUMENT WITH RESPECT TO WHICH THIS CERTIFICATE MAY BE ISSUED OR MAY PERTAIN, THE INSURANCE AFFORDED BY THE POLICIES DESCRIBED HEREIN IS SUBJECT TO ALL THE TERMS, EXCLUSIONS AND CONDITIONS OF SUCH POLICIES. LIMITS SHOWN MAY HAVE BEEN REDUCED BY PAID CLAIMS.

| INSR LTR | INSURANCE   | ADD'L SUBR INSR | SUBR YWV | POLICY NUMBER | POLICY EFF (MM/DD/YYYY) | POLICY EXP (MM/DD/YYYY) | LIMITS  |
|----------|---|-----------------|----------|---------------|-------------------------|-------------------------|---|
| A        | GENERAL LIABILITY   |                 |          | GLP007951603  | 02/24/13                | 02/24/14                | EACH OCCURRENCE \$ 1,000,000<br>DAMAGE TO RENTED PREMISES (Ea occurrence) \$ 100,000<br>MED. EXP (Any one person) \$ 5,000<br>PERSONAL & ADV INJURY \$ 1,000,000<br>GENERAL AGGREGATE \$ 2,000,000<br>PRODUCTS - COMP/OP AGG \$ 2,000,000 |
|          | COMMERICAL GENERAL LIABILITY                              |                 |          |               |                         |                         |   |
|          | CLAIMS-MADE   |                 | X        |               |                         |                         |   |
|          | OCUR  |                 |          |               |                         |                         |   |
|          | GEN'L AGGREGATE LIMIT APPLIES PER:                        |                 |          |               |                         |                         |   |
|          | X POLICY SUBJECT LOC                                      |                 |          |               |                         |                         |   |
|          | AUTOMOBILE LIABILITY                                      |                 |          |               |                         |                         |   |
|          | ANY AUTO  |                 |          |               |                         |                         |   |
|          | ALL OWNED AUTOS   |                 |          |               |                         |                         |   |
|          | SCHEDULED AUTOS   |                 |          |               |                         |                         |   |
|          | HIRE AUTOS  |                 |          |               |                         |                         |   |
|          | NON-OWNED AUTOS   |                 |          |               |                         |                         |   |
|          | UMBRELLA LIAB   |                 |          |               |                         |                         |   |
|          | EXCESS LIAB   |                 |          |               |                         |                         |   |
|          | DEDUCTIBLE  |                 |          |               |                         |                         |   |
|          | RETENTION \$  |                 |          |               |                         |                         |   |
|          | WORKERS COMPENSATION AND EMPLOYERS' LIABILITY             |                 |          |               |                         |                         |   |
|          | ANY PROPRIETOR/PARTNER/EXECUTIVE OFFICER/MEMBER EXCLUDED? |                 |          |               |                         |                         |   |
|          | (Mandatory in NH)   |                 |          |               |                         |                         |   |
|          | If yes, describe under DESCRIPTION OF OPERATIONS below    |                 |          |               |                         |                         |   |
|          | COMBINED SINGLE LIMIT (Ea accident) \$                    |                 |          |               |                         |                         |   |
|          | BODILY INJURY (Per person) \$                             |                 |          |               |                         |                         |   |
|          | BODILY INJURY (Per accident) \$                           |                 |          |               |                         |                         |   |
|          | PROPERTY DAMAGE (Per accident) \$                         |                 |          |               |                         |                         |   |
|          | EACH OCCURRENCE \$  |                 |          |               |                         |                         |   |
|          | AGGREGATE \$  |                 |          |               |                         |                         |   |
|          | WC STATUS-TORY LIMITS                                     |                 |          |               |                         |                         |   |
|          | E.L. EACH ACCIDENT \$                                     |                 |          |               |                         |                         |   |
|          | E.L. DISEASE-EA EMPLOYEE \$                               |                 |          |               |                         |                         |   |
|          | E.L. DISEASE-POLICY LIMIT \$                              |                 |          |               |                         |                         |   |

DESCRIPTION OF OPERATIONS / LOCATIONS / VEHICLES (Attach ACORD 101. Additional Remarks Schedule, if more space is required)  
3534 CULLEN LAKE SHORE DR

**CERTIFICATE HOLDER**

CITY OF BELLE ISLE  
1600 NELA AVE  
BELLE ISLE FL 32809

**CANCELLATION**

SHOULD ANY OF THE ABOVE DESCRIBED POLICIES BE CANCELLED BEFORE THE EXPIRATION DATE THEREOF, NOTICE WILL BE DELIVERED IN ACCORDANCE WITH THE POLICY PROVISIONS.

AUTHORIZED REPRESENTATIVE

Attention: Collina cgast@universaleengineering.com

*Michelle S. Delaney*  
Michelle S. Delaney

ACORD 25 (2009/09)      © 1988-2009 ACORD CORPORATION. All rights reserved.      The ACORD name and logo are registered marks of ACORD



06-06-2012

JEFF ATWATER  
CHIEF FINANCIAL OFFICER  
STATE OF FLORIDA  
DEPARTMENT OF FINANCIAL SERVICES  
DIVISION OF WORKERS' COMPENSATION

\* \* CERTIFICATE OF ELECTION TO BE EXEMPT FROM FLORIDA WORKERS' COMPENSATION LAW \* \*  
CONSTRUCTION INDUSTRY EXEMPTION

This certifies that the individual listed below has elected to be exempt from Florida Workers' Compensation law.

EFFECTIVE DATE: 06/06/2012 EXPIRATION DATE: 06/06/2014

PERSON: TISDELL JASON A

FEIN: 261441563

BUSINESS NAME AND ADDRESS:

CARDELL CONSTRUCTION LLC  
1115 EAST LIVINGSTON STREET  
ORLANDO FL 32803

SCOPES OF BUSINESS OR TRADE:

1- LICENSED GENERAL CONTRACTOR 2- CERTIFIED GENERAL CONTRACTOR

IMPORTANT: Pursuant to Chapter 440 . 06(14), F.S., an officer of a corporation who elects exemption from this chapter by filing a certificate of election under this section may not recover benefits or compensation under this chapter. Pursuant to Chapter 440.05(12), F.S., Certificates of election to be exempt... apply only within the scope of the business or trade listed on the notice of election to be exempt. Pursuant to Chapter 440.05(13), F.S., Notices of election to be exempt and certificates of election to be exempt shall be subject to revocation if, at any time after the filing of the notice or the issuance of the certificate, the person named on the notice or certificate no longer meets the requirements of this section for issuance of a certificate. The department shall revoke a certificate at any time for failure of the person named on the certificate to meet the requirements of this section.

DWC-252 CERTIFICATE OF ELECTION TO BE EXEMPT REVISED 01-11

QUESTIONS? (850) 413-1609

PLEASE CUT OUT THE CARD BELOW AND RETAIN FOR FUTURE REFERENCE

STATE OF FLORIDA  
DEPARTMENT OF FINANCIAL SERVICES  
DIVISION OF WORKERS' COMPENSATION  
CONSTRUCTION INDUSTRY  
CERTIFICATE OF ELECTION TO BE EXEMPT FROM FLORIDA  
WORKERS' COMPENSATION LAW



EFFECTIVE 06/06/2012 EXPIRATION DATE: 06/06/2014

PERSON: JASON A TISDELL

FEIN: 261441563

BUSINESS NAME AND ADDRESS:

CARDELL CONSTRUCTION LLC  
1115 EAST LIVINGSTON STREET  
ORLANDO, FL 32803

SCOPE OF BUSINESS OR TRADE:

1- LICENSED GENERAL CONTRACTOR 2- CERTIFIED GENERAL CONTRACTOR

IMPORTANT

F Pursuant to Chapter 440.05(14), F.S., an officer of a corporation who elects exemption from this chapter by filing a certificate of election under this section may not recover benefits or compensation under this chapter.

H Pursuant to Chapter 440.05(12), F.S., Certificates of election to be exempt... apply only within the scope of the business or trade listed on the notice of election to be exempt.

R Pursuant to Chapter 440.05(13), F.S., Notices of election to be exempt and certificates of election to be exempt shall be subject to revocation if, at any time after the filing of the notice or the issuance of the certificate, the person named on the notice or certificate no longer meets the requirements of this section for issuance of a certificate. The department shall revoke a certificate at any time for failure of the person named on the certificate to meet the requirements of this section.

QUESTIONS? (850) 413-1609

CUT HERE

\* Carry bottom portion on the job, keep upper portion for your records.

DWC-252 CERTIFICATE OF ELECTION TO BE EXEMPT REVISED 01-11



**STATE OF FLORIDA**

**DEPARTMENT OF BUSINESS AND PROFESSIONAL REGULATION**

**CONSTRUCTION INDUSTRY LICENSING BOARD  
1940 NORTH MONROE STREET  
TALLAHASSEE FL 32399-0783**

**(850) 487-1395**

**TISDELL, JASON ANDREW  
CARDELL, CONSTRUCTION LLC  
1115 EAST LIVINGSTON STREET  
ORLANDO FL 32803**

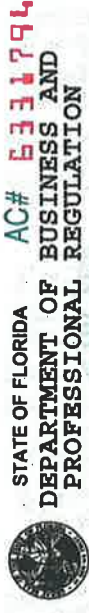

STATE OF FLORIDA AC# **6331794**  
DEPARTMENT OF BUSINESS AND  
PROFESSIONAL REGULATION

CGC1515577 09/01/12 110420821

**CERTIFIED GENERAL CONTRACTOR  
TISDELL, JASON ANDREW  
CARDELL, CONSTRUCTION LLC**

IS CERTIFIED under the provisions of Ch. 489 FS  
Expiration date: AUG 31, 2014 L12090101344

**Congratulations!** With this license you become one of the nearly one million Floridians licensed by the Department of Business and Professional Regulation. Our professionals and businesses range from architects to yacht brokers, from boxers to barbeque restaurants, and they keep Florida's economy strong.

Every day we work to improve the way we do business in order to serve you better. For information about our services, please log onto [www.myfloridalicense.com](http://www.myfloridalicense.com). There you can find more information about our divisions and the regulations that impact you, subscribe to department newsletters and learn more about the Department's initiatives.

Our mission at the Department is: License Efficiently, Regulate Fairly. We constantly strive to serve you better so that you can serve your customers. Thank you for doing business in Florida, and congratulations on your new license!

DETACH HERE

THIS DOCUMENT HAS A COLORED BACKGROUND • MICROPRINTING • LINEMARK™ PATENTED PAPER

**AC# 6331794**

**STATE OF FLORIDA**

**DEPARTMENT OF BUSINESS AND PROFESSIONAL REGULATION  
CONSTRUCTION INDUSTRY LICENSING BOARD**

**SEQ# L12090101344**

| DATE       | BATCH NUMBER | LICENSE NBR |
|------------|--------------|-------------|
| 09/01/2012 | 110420821    | CGC1515577  |

**The GENERAL CONTRACTOR**

**Named below IS CERTIFIED**

**Under the provisions of Chapter 489 FS.**

**Expiration date: AUG 31, 2014**

**TISDELL, JASON ANDREW  
CARDELL, CONSTRUCTION LLC  
1115 EAST LIVINGSTON STREET  
ORLANDO FL 32803**

**RICK SCOTT  
GOVERNOR**

**KEN LAWSON  
SECRETARY**

RECEIVED BY FAX





# CITY OF ORLANDO

ECONOMIC DEVELOPMENT • PERMITTING

Local Business Tax Receipt  
City Hall, 400 South Orange Avenue, First Floor  
Post Office Box 4990  
Orlando, FL 32802-4990

Phone: 407.246.2204 Fax: 407.246.3420

PROMPT! Interactive Voice Response System: 407.246.4444  
Visit our website: [www.CityofOrlando.net/permits](http://www.CityofOrlando.net/permits)

**CITY OF ORLANDO**  
ECONOMIC DEVELOPMENT  
PERMITTING SERVICES  
**LOCAL BUSINESS TAX RECEIPT**  
(Formerly known as "Business License," changed per state law HB1265-2006)

Issued Date: 10/01/2013  
Expiration Date: 09/30/2014

**Business Name**  
CARDELL CONSTRUCTION LLC  
1115 E LIVINGSTON ST  
ORLANDO, FL 32803

**Business Type(s):**  
CONTRA 1524 CONTRACTOR DBPR

**Business Owner**  
JASON A TISDELL

**Business Location:**  
3302 Heled Av

**Fees:**  
Administration Fee 20.00  
2014 Business Tax 110.26  
Total Paid: \$130.26

**Case Number:** BHS-0017484

**2013-2014**

**NOTICE-THIS RECEIPT ONLY EVIDENCES PAYMENT OF THE LOCAL BUSINESS TAX PURSUANT TO CH. 205, FLORIDA STATUTES. IT DOES NOT PERMIT THE HOLDER TO OPERATE IN VIOLATION OF ANY CITY, STATE, OR FEDERAL LAW. CITY PERMITTING MUST BE NOTIFIED OF ANY MATERIAL CHANGE TO THE INFORMATION FOUND HEREIN BELOW. THIS RECEIPT DOES NOT CONSTITUTE AN ENDORSEMENT OR APPROVAL OF THE HOLDER'S SKILL OR COMPETENCY.**