



City of Belle Isle Job Site Card Window/Door PERMIT 2019-08-017
PERMIT MUST BE POSTED ON SITE - A permit expires in 6 months if approved inspections are not recorded /schedule within that time frame. **You are responsible for scheduling and keeping track of all inspections.**

Permit Number: 2019- 08-017
Site Address: 6524 Franconia Dr 32812
Class: Residential **Subdivision:**
Description of Work: 1 **Door** (s) / Size for Size

Issue Date: 08/06/2019
Parcel #: 20-23-30-1618-00-270

Issued: Lowe's Home Centers LLC
Name: Peter Cafaro

Business Phone: 407 468-1010
Contractor License #: CGC158417

Payment Date & Method: 8 / 6 / 2019 Picked up or sent by _____ Emailed
 Visa Master Card Amex Discover Check / Money Order # 2980

Schedule Inspections via Email at: BDscheduling@universalengineering.com
SCHEDULE INSPECTIONS BY 3:00 PM CUT OFF TIME
Inspection Results Will Be Sent Out the Following Business Day

"WARNING TO OWNER: YOUR FAILURE TO RECORD A NOTICE OF COMMENCEMENT MAY RESULT IN YOUR PAYING TWICE FOR IMPROVEMENTS TO YOUR PROPERTY. IF YOU INTEND TO OBTAIN FINANCING, CONSULT WITH YOUR LENDER OR AN ATTORNEY BEFORE RECORDING YOUR NOTICE OF COMMENCEMENT."

BUILDING	INSPECTOR	DATE	COMMENTS
900 In Progress			
910 Final			

Inspection requests are to be emailed to BDscheduling@UniversalEngineering.com; a confirmation email will be sent back to you upon scheduling. Next-Day Inspection requests must be made by 3pm. Please include the following in your request: Permit #, project address, type of inspection, date of the requested inspection, a contact name & a contact phone number. AM or PM may be requested but cannot be guaranteed. Inspection results will be sent out the following business day. A permit expires in 6 months if approved inspections are not recorded /scheduled within that time frame. You are responsible for scheduling and keeping track of all your inspections –

Universal Engineering Sciences - 3532 Maggie Blvd., Orlando, FL 32811
 Tel 407-581-8161 * Fax 407-581-0313 * www.universalengineering.com



City of Belle Isle
 Universal Engineering Sciences 3532 Maggie Blvd., Orlando, FL 32811
 Tel 407-581-8161 * Fax 407-581-0313 * www.universalleng.com

RECEIVED
 AUG 01 2019

APPLICATION FOR SIZE-FOR-SIZE WINDOW / DOOR PERMIT

WARNING TO OWNER: YOUR FAILURE TO RECORD A NOTICE OF COMMENCEMENT MAY RESULT IN YOUR PAYING TWICE FOR IMPROVEMENTS TO YOUR PROPERTY. A NOTICE OF COMMENCEMENT MUST BE RECORDED AND POSTED ON THE JOB SITE BEFORE THE FIRST INSPECTION. IF YOU INTEND TO OBTAIN FINANCING, CONSULT WITH YOUR LENDER OR AN ATTORNEY BEFORE RECORDING YOUR NOTICE OF COMMENCEMENT.

DATE OF APPLICATION: 8/1/19

PERMIT NUMBER 2019-08-017

PLEASE PRINT. The undersigned hereby applies for a permit to make installations as indicated below:

Project Address 6524 FRANCONIA DR, Belle Isle, FL 32809 X 32812

Property Owner PETER ORSAEO Phone 407-230-3028

Property Owner's Mailing Address SAME City _____

State _____ Zip Code _____ Parcel Id Number: 20-23-30-1618-00-270

REQUIRED! To obtain this information, please visit <http://www.ocpafi.org/Searches/ParcelSearch.aspx>

Type of Building: Residential Commercial Other

VISA 2880
PAID
 8-6-19

- **REQUIRED!** Florida Product Approval Screen Printout from www.floridabuilding.org showing the Code Version
- **REQUIRED!** Florida Product Approval Installation Instructions from www.floridabuilding.org (not the manufacturer instructions)
- **REQUIRED!** Copies of your General Liability & Worker's Comp Insurance Certificate & State and Local Licenses

Please indicate the nature of work by completing the information below:

Number of Size-for-Size Windows: _____ Number of Size-for-Size Doors: 1 Job Valuation: \$650.16

ISTK 25
 +2 12
 37.5

I hereby certify that the above is true and correct to the best of my knowledge and make Application for Permit as outlined above, and if same is granted I agree to conform to all Florida Building Code Regulations and City Ordinances regulating same and in accordance with plans submitted. The issuance of this permit does not grant permission to violate any applicable Town and/or State of Florida codes and/or ordinances. By signing below, I recognize Republic Services is by legal contract the sole authorized provider of garbage, recycling, yard waste, and commercial garbage and construction debris collection and disposal services with the city limits of the City. Contractors, homeowners and commercial businesses may contact Republic Services at 407-293-8000 to setup accounts for Commercial, Construction Roll Off, or other services needed. Rates are fixed by contract and are available at City Hall or from Republic Services. The City enforces the contract through its code enforcement office. Failure to comply will result in a stop work order.

BY SIGNING THIS APPLICATION, YOU ARE CERTIFYING THAT YOU ARE ACTING AS THE OWNER'S AGENT FOR THIS PERMIT:

LICENSE HOLDER SIGNATURE _____ LICENSE # CGC1508417

LICENSE HOLDER NAME PETER A CAFARO III COMPANY NAME LOWE'S HOME CENTERS, LLC

Street Address PO BOX 781993

City ORLANDO State FL Zip Code 32878 Phone Number 407-468-1010

Email Address NANHOLMESPERMITS@GMAIL.COM

Zoning Fee \$ 0
 Permit Fee \$ 25
 Review Fee \$ 12.00
 2.5% Florida Surcharge \$ 4.50 min
 Total Permit Fee \$ 41.50

Building Official: [Signature] Date 8-5-19
 Verified Contractor's Licenses & Insurance are on file [Signature] Date 8-5-19



- [Searches](#)
- [Sales Search](#)
- [Results](#)
- [Property Record Card](#)
- [My Favorites](#)

[Sign up for e-Notify..](#)

6524 Franconia Dr < 20-23-30-1618-00-270 >

Name(s) Orsaeo Peter P Napoli Dawnann Mailing Address On File 6524 Franconia Dr Belle Isle, FL 32812-3620 Incorrect Mailing Address?	Physical Street Address 6524 Franconia Dr Postal City and Zipcode Orlando, FL 32812 Property Use 0103 - Single Fam Class III Municipality Belle Isle
--	--



View 2018 Property Record Card

- [Property Features](#)
- [Values, Exemptions and Taxes](#)
- [Sales Analysis](#)
- [Location Info](#)
- [Market Stats](#)
- [Update Information](#)

2019 values will be available in August of 2019.

Property Description

[View Plat](#)

CONWAY GROVES UNIT 1 36/3 LOT 27

Total Land Area 11,067 sqft (+/-) | 0.25 acres (+/-) [GIS Calculated](#) [Notice](#)

Land

Land Use Code	Zoning	Land Units	Unit Price	Land Value	Class Unit Price	Class Value
0100 - Single Family	R-1-AA	1 LOT(S)	working...	working...	working...	working...

Page 1 of 1 (1 total records)

Buildings

Important Information		Structure				
	Model Code:	01 - Single Fam Residence	Actual Year Built:	1997	Gross Area:	4415 sqft
	Type Code:	0103 - Single Fam Class III	Beds:	4	Living Area:	3409 sqft
	Building Value:	working...	Baths:	2.5	Exterior Wall:	Concrete Block Stucco
	Estimated New Cost:	working...	Floors:	2	Interior Wall:	Drywall

Page 1 of 1 (1 total records)

Extra Features

Description	Date Built	Units	XFOB Value
SCR2 - Scrn Enc 2	01/01/1997	1 Unit(s)	working...

Page 1 of 1 (1 total records)

This Data Printed on 08/01/2019 and System Data Last Refreshed on 07/31/2019

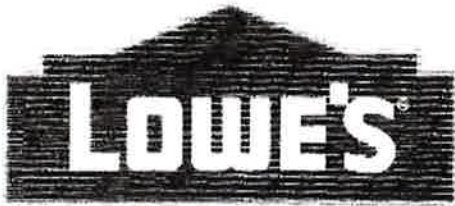

Lowes Home Centers LLC
 Permit & License Administration
 PO Box 781993
 Orlando, FL 32878 – 1993
 Bus. 407/832-8085
 Fax. 407/393-9151

Limited Power of Attorney

Date: 8/1/19

To: Building Department

From: Peter Anthony Cafaro III

I hereby name and appoint Nan Holmes, Mindy Holmes, Raymond Holmes and Jackie Caines, a permit service for Lowe's, to be my lawful attorney in fact to act for me and apply to

BELLE ISLE for a DOOR permit for work to be performed at a location described as:

(Address of Job)

6524 FRANCONIA DR

(Owner of Property)

ORSAEO

And to sign my name and do all things necessary to this appointment.

Thank you for your assistance.

Sincerely,

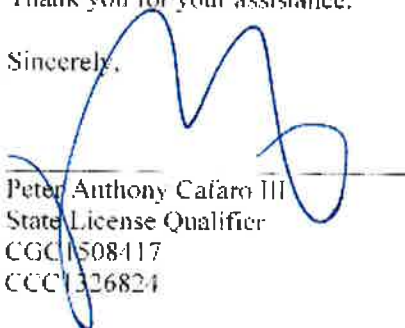
 Peter Anthony Cafaro III
 State License Qualifier
 CGC1508417
 CCC1326824

State of Florida County of Orange

The forgoing instrument was acknowledged before me as Peter Anthony Cafaro III, who is personally known to me and who did not take an oath.

Sworn to and subscribed before me this 1 day of AUG, 2019

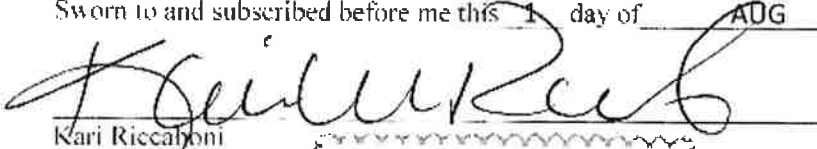

Kari Riccaboni
 Notary Public
 My commission expires



STORE COPY



INSTALLATION SERVICES CUSTOMER CONTRACT - MWORK - INT/EXT/PATIO DOOR

LOWE'S OF S.E. ORLANDO, FL. STORE # 1598
 3500 SOUTH SEMORAN BLVD.
 ORLANDO, FL 32822-2581

STORE PHONE: (407) 382-2211
 SALESPERSON: BRYAN WINTERHOFF
 SALESPERSON ID: 632043
 Document Print Date : 07/30/2019

This is only a Quote for the merchandise and services printed below. This becomes an agreement upon payment and issuance of a Lowe's receipt, upon which the entire agreement, including the specifically completed pages of this document, the Terms and Conditions included with this document, the applicable portion(s) of Lowe's receipt, and any other addenda or attachments hereto, shall be referred to herein as this "Contract."

PLEASE READ THIS ENTIRE DOCUMENT, INCLUDING THE "TERMS AND CONDITIONS," BEFORE SIGNING.

Lowe's Registration or Contractor License Number / Lowe's Contractor Name

Florida Contractor License Number CGC1508417

S O L D T O	Customer Name			Home Phone
	PETER ORSAEO			407-230-3028
	Customer Address			Other Phone
	6524 FRANCONIA DR			
	City	State / Province	Zip / Postal Code	
BELLE ISLE	FL	32812		
	Installation Address			
	6524 FRANCONIA DR			
	Installation City	Installation State/Province	Installation Zip/Postal Code	
	BELLE ISLE	FL	32812	

MERCHANDISE AND INSTALLATION SUMMARY

MERCHANDISE SUMMARY

1206 : 1206 : STK : 1-2-8 SELECT PINE BOARD : 1-2-8 SELECT PINE BOARD : PRECISION LUMBER - QTY 3
 4874 : 366-PFJ7 : STK : PFJCASE366 2-1/4-INX11/16-INX7-FT : PFJCASE366 2-1/4-INX11/16-INX7-FT : METRIE INDUSTRIES INC - QTY 3



Materials Price	\$ 34.41
------------------------	-----------------

INSTALLATION DESCRIPTION

Door type : Exterior

Location of new door(s) : Front Door

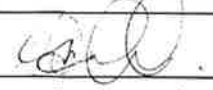
STORE COPY

By: <u></u> (Seal)	
Print Name: <u>Emilio Williams</u>	
<u>3500 S Tamara Blvd</u>	<u></u> (Seal)
Address	Owner
<u>Orlando FL 32822</u>	<u>PETER ORSAEO</u>
City State / Province Zip / Postal Code	Print Name
	Co-Owner or Witness (Seal)
	Print Name

Customer acknowledges receipt of a true copy which was completely filled in prior to Customer's execution hereof. You the customer may cancel this transaction at any time prior to midnight on the third business day after the date of this transaction. See the attached Notice of Right to Cancel for an explanation of this right.

STORE COPY

Select new door : Double Pre-Hung	Hardwood door : No
Sidelights or transoms : No	Number of additional holes bored for accessories : None
Install specialized mortise hardware : No	Install storm door : No
Lead safe practices : No	Total linear feet of custom trim to be Installed : 0
Deliver door : Yes	Customer understands scope of the project : Yes
Who will obtain permit : Third Party	Permit fee : Yes
Additional miles traveled over 20 : 0	Access fee : None
Dump entry Fee : Yes	Describe other work needed : None
Comments : No Comment	

Labor Charges	\$ 650.75
Detail Deduction	-\$ 35.00

Additional Specifications:

Notation: Lowe's will not make structural modifications, paint or stain or remove/reinstall security system equipment. Customer is responsible to advise if property is governed by Historic District Regulations.

Additional Specifications: Federal law requires Lowe's to provide you with the pamphlet *Renovate Right: Important Lead Hazard Information for Families, Child Care Providers and Schools*. By signing this Contract, Customer acknowledges having received a copy of this pamphlet before work began informing Customer of the potential risk of the lead hazard exposure from renovation activity to be performed in Customer's dwelling unit.

PHOTO RELEASE: Customer grants to Lowe's and Lowe's employees and independent contractors the right to take photographs of the Premises where installation Services will be performed and all work performed at the Premises related to this Contract, and irrevocably grants to Lowe's all right, title, interest in and to the photographs for use in all markets and media, worldwide, in perpetuity. Customer authorizes Lowe's to copyright, use and publish the photographs in print and/or electronically, and agrees that Lowe's may use such photographs for any lawful purpose, including, but not limited to, marketing, advertising, publicity, illustration, training and Web content. By initialing here, Customer agrees to the foregoing. W [Customer to initial to the left].

NOTICE TO CUSTOMER - PRICE CALCULATIONS: In order to properly perform the installation of certain Goods, the Contract Price may include more Goods than actually will be installed based on the measured square footage of the Project Area. As a result, the parties agree that the lump-sum Price stated in this Contract is calculated upon both the value of the estimated Goods required to fulfill the Contract (including waste), which may exceed the actual square footage of the Project Area, and the labor which may be estimated based on the amount of Goods required to fulfill the contract (including waste). By signing this Contract below, Customer acknowledges receipt of this notice and agrees and understands that the Price includes these costs which may not be refunded once the Installation Services are performed.

NOTICE OF ARBITRATION AGREEMENT

This Contract provides that all claims by Customer or Lowe's will be resolved by BINDING ARBITRATION. Customer and Lowe's GIVE UP THE RIGHT TO GO TO COURT to enforce this Contract (EXCEPT for matters that may be taken to SMALL CLAIMS COURT). Lowe's and Customer's rights will be determined by a NEUTRAL ARBITRATOR and NOT a judge or jury. Lowe's and Customer are entitled to a FAIR HEARING. But the arbitration procedures are SIMPLER AND MORE LIMITED THAN RULES APPLICABLE IN COURT. Arbitrator decisions are as enforceable as any court order and are subject to VERY LIMITED REVIEW BY A COURT. FOR MORE DETAILS: Review the section titled ARBITRATION AGREEMENT, WAIVER OF JURY TRIAL AND WAIVER OF CLASS ACTION ADJUDICATION found in the Terms and Conditions of this Contract.

STORE COPY

TOTAL CHARGES OF ALL MERCHANDISE AND SERVICES		where applicable
SUB-TOTAL		\$ 650.16
TAX		\$ 0.00
DELIVERY		\$ 0.00
ORDER TOTAL		\$ 650.16
BALANCE DUE		

Work is to commence upon reasonable availability of Contractor which is anticipated to be TBD (fill in date).
 Estimated completion date is TBD (fill in date).

NOTICE TO CUSTOMER

All items listed in this contract and specification sheet(s) are to be installed under conditions agreed upon at time of purchase and at the price appearing on this contract form. This assumes sound existing substructures, superstructure and points of attachments. Extra labor or material incident to installation necessitated by defective substructures, superstructure, points of attachment, or the moving of fixtures or appliances to be billed at extra cost to customer. DO NOT SIGN THIS CONTRACT UNTIL COMPLETE AND YOU HAVE READ THE TERMS AND CONDITIONS OF THIS CONTRACT. BY SIGNING BELOW, YOU ARE ACKNOWLEDGING THAT YOU HAVE READ, UNDERSTAND AND AGREE TO THE TERMS AND CONDITIONS SET FORTH ON THIS CONTRACT. YOU ARE ENTITLED TO A COPY OF THIS CONTRACT AT THE TIME OF SIGNATURE.

NOTICE TO OWNER:-ACCORDING TO FLORIDA'S CONSTRUCTION LIEN LAW (SECTIONS 713.001- 713.37, FLORIDA STATUTES). THOSE WHO WORK ON YOUR PROPERTY OR PROVIDE MATERIALS AND SERVICES AND ARE NOT PAID IN FULL HAVE A RIGHT TO ENFORCE THEIR CLAIM FOR PAYMENT AGAINST YOUR PROPERTY. THIS CLAIM IS KNOWN AS A CONSTRUCTION LIEN. IF YOUR CONTRACTOR OR A SUBCONTRACTOR FAILS TO PAY SUBCONTRACTORS, SUB-SUBCONTRACTORS, OR MATERIAL SUPPLIERS, THOSE PEOPLE WHO ARE OWED MONEY MAY LOOK TO YOUR PROPERTY FOR PAYMENT, EVEN IF YOU HAVE ALREADY PAID YOUR CONTRACTOR IN FULL. IF YOU FAIL TO PAY YOUR CONTRACTOR, YOUR CONTRACTOR MAY ALSO HAVE A LIEN ON YOUR PROPERTY. THIS MEANS IF A LIEN IS FILED YOUR PROPERTY COULD BE SOLD AGAINST YOUR WILL TO PAY FOR LABOR, MATERIALS, OR OTHER SERVICES THAT YOUR CONTRACTOR OR A SUBCONTRACTOR MAY HAVE FAILED TO PAY. TO PROTECT YOURSELF, YOU SHOULD STIPULATE IN THIS CONTRACT THAT BEFORE ANY PAYMENT IS MADE, YOUR CONTRACTOR IS REQUIRED TO PROVIDE YOU WITH A WRITTEN RELEASE OF LIEN FROM ANY PERSON OR COMPANY THAT HAS PROVIDED TO YOU A "NOTICE TO OWNER." FLORIDA'S CONSTRUCTION LIEN LAW IS COMPLEX, AND IT IS RECOMMENDED THAT YOU CONSULT AN ATTORNEY.

WITNESS OUR HAND(S) AND SEAL(S) BELOW THIS July DAY OF 30 2019.
 Lowe's Home Centers, LLC



City of Belle Isle

Universal Engineering Sciences 3532 Maggie Blvd., Orlando, FL 32811
 Tel 407-581-8161 * Fax 407-581-0313 * www.universalengineering.com

Product Approval Form

DATE: 8/1/19

PERMIT # _____

PROJECT ADDRESS 6524 FRANCONIA DR, Belle Isle, FL 32809 ^X 32812

As required by Florida Statue 553.842 and Florida Administrative Code 9B-72m, please provide the information and approval numbers of the building components listed below if they will be utilized on the building or structure. FL Approved products are listed online at www.floridabuilding.org or can be obtained from the local product supplier. The following information must be turned in with permit application and available onsite for inspections:

1. **This Product Approval Cover Sheet**
2. **Internet screen from FloridaBuilding.org showing PA#, approval and code edition stamped**
3. **Manufacturer's *installation* details from FloridaBuilding.org and requirements for each product stamped**

Product Type	Manufacturer	Model/Series	FL Product Approval #	Product Type	Manufacturer	Model/Series	FL Product Approval #
EXTERIOR DOORS				WALL PANELS			
Swinging	JELD WEN	FIBERGLASS	13541.4-R15	Sliding			
Sliding				Soffits			
Sectional/Rollup				Storefront			
Other				Glass Block			
				Other			
WINDOWS				ROOFING PRODUCTS			
Single/Dbf Hung				Asphalt Shingles			
Horizontal Slider				Non Struct Metal			
Casement				Roofing Tiles			
Fixed				Single Ply Roof			
Mullion				Underlayment			
Skylights				Other			
Other							
STRUCTURAL COMPONENTS				OTHER			
Wood Connectors							
Wood Anchors							
Truss Plates							
Insulation Forms							
Lintels							
Other							

It is the applicant's responsibility to verify that specific products have been installed in accordance with their limitations and with the minimum required design pressures for the structure. Specific compliance will be verified during field inspections.

Applicant Signature 

Date 8/1/19

FLORIDA DEPARTMENT OF
Business & Professional Regulation



[BCIS Home](#) | [Log In](#) | [User Registration](#) | [Hot Topics](#) | [Submit Surcharge](#) | [Stats & Facts](#) | [Publications](#) | [Contact Us](#) | [BCIS Site Map](#) | [Links](#) | [Search](#)



Product Approval
USER: Public User

[Product Approval Menu](#) > [Product or Application Search](#) > [Application List](#) > **Application Detail**

OFFICE OF THE
SECRETARY

FL # FL13541-R15
Application Type Editorial Change
Code Version 2017
Application Status Approved
 *Approved by DBPR. Approvals by DBPR shall be reviewed and ratified by the POC and/or the Commission if necessary.

Comments
Archived

Product Manufacturer JELD-WEN
Address/Phone/Email 3737 Lakeport Blvd
 Klamath Falls, OR 97601
 (800) 535-3936
 fbc1@jeld-wen.com

Authorized Signature Rylee Sumner Fricks
 fbc1@jeld-wen.com

Technical Representative JELD-WEN Corporate Customer Service
Address/Phone/Email 3737 Lakeport Blvd.
 Klamath Falls, OR 97601
 (800) 535-3936
 customerserviceagents@jeld-wen.com

Quality Assurance Representative
Address/Phone/Email

Category Exterior Doors
Subcategory Swinging Exterior Door Assemblies

Compliance Method Certification Mark or Listing

Certification Agency National Accreditation & Management Institute
Validated By National Accreditation & Management Institute

Referenced Standard and Year (of Standard)	Standard	Year
	AAMA 1304	2002
	ASTM E283	2004
	ASTM E330	2002
	TAS 202	1994

Equivalence of Product Standards
Certified By

Product Approval Method Method 1 Option A

Date Submitted 05/21/2019
 Date Validated 05/22/2019
 Date Pending FBC Approval
 Date Approved 05/30/2019

Summary of Products

FL #	Model, Number or Name	Description
13541.1	A. Design Pro / Smooth Pro / Studio Fiberglass	Single (X) Opaque Fiberglass Door, 3'-0" x 6'-8" and 3'-0" x 8'-0", Inswing and Outswing
Limits of Use Approved for use in HVHZ: No Approved for use outside HVHZ: Yes Impact Resistant: No Design Pressure: +50/-50 Other:		Certification Agency Certificate FL13541_R15_C_CAC_NI011906.01-R11.pdf FL13541_R15_C_CAC_NI011906-R10.pdf Quality Assurance Contract Expiration Date 03/30/2026 Installation Instructions FL13541_R15_II_A010831A_SS_2014-09-26.pdf Verified By: Hermes F. Norero 73778 Created by Independent Third Party: Yes Evaluation Reports FL13541_R15_AE_PER2742_SS_2014-09-26.pdf Created by Independent Third Party: Yes
13541.2	B. Design Pro / Smooth Pro Fiberglass	Single (X) Glazed Fiberglass Door, 3'-0" x 6'-8" and 3'-0" x 8'-0", Inswing and Outswing
Limits of Use Approved for use in HVHZ: No Approved for use outside HVHZ: Yes Impact Resistant: No Design Pressure: +50/-50 Other:		Certification Agency Certificate FL13541_R15_C_CAC_NI011921.01-R10.pdf FL13541_R15_C_CAC_NI011921-R11.pdf Quality Assurance Contract Expiration Date 03/30/2026 Installation Instructions FL13541_R15_II_A010832A_SS_2014-09-26.pdf Verified By: Hermes F. Norero, P.E. 73778 Created by Independent Third Party: Yes Evaluation Reports FL13541_R15_AE_PER2743_SS_2014-09-26.pdf Created by Independent Third Party: Yes
13541.3	C. Design Pro / Smooth Pro / Studio Fiberglass	Double (XX) Opaque Fiberglass Door, 6'-0" x 6'-8" and 6'-0" x 8'-0", Inswing and Outswing
Limits of Use Approved for use in HVHZ: No Approved for use outside HVHZ: Yes Impact Resistant: No Design Pressure: +50/-50 Other:		Certification Agency Certificate FL13541_R15_C_CAC_NI011907.01-R10.pdf FL13541_R15_C_CAC_NI011907-R10.pdf Quality Assurance Contract Expiration Date 03/30/2026 Installation Instructions FL13541_R15_II_A010833A_SS_2014-09-26.pdf Verified By: Hermes F. Norero 73778 Created by Independent Third Party: Yes Evaluation Reports FL13541_R15_AE_PER2744_SS_2014-09-26.pdf Created by Independent Third Party: Yes
13541.4	D. Design Pro / Smooth Pro Fiberglass	Double (XX) Glazed Fiberglass Door, 6'-0" x 6'-8" and 6'-0" x 8'-0", Inswing and Outswing
Limits of Use Approved for use in HVHZ: No Approved for use outside HVHZ: Yes Impact Resistant: No Design Pressure: +50/-50 Other:		Certification Agency Certificate FL13541_R15_C_CAC_NI011908.01-R11.pdf FL13541_R15_C_CAC_NI011908-R11.pdf Quality Assurance Contract Expiration Date 03/30/2026 Installation Instructions FL13541_R15_II_A010834A_SS_2014-09-26.pdf Verified By: Hermes F. Norero 73778 Created by Independent Third Party: Yes Evaluation Reports FL13541_R15_AE_PER2745_SS_2014-09-26.pdf Created by Independent Third Party: Yes
13541.5	E. Design Pro / Smooth Pro / Studio Fiberglass	Single with side lite(s) (X,O/ O,X/ O,X,O) Opaque Fiberglass Door, 9'-0" x 6'-8" and 9'-0" x 8'-0", Inswing and Outswing
Limits of Use Approved for use in HVHZ: No Approved for use outside HVHZ: Yes Impact Resistant: No Design Pressure: N/A Other:		Certification Agency Certificate FL13541_R15_C_CAC_NI011910.01-R11.pdf FL13541_R15_C_CAC_NI011910-R11.pdf Quality Assurance Contract Expiration Date 03/30/2026 Installation Instructions FL13541_R15_II_A010835A_SS_2014-09-26.pdf

		Verified By: Hermes F. Norero 73778 Created by Independent Third Party: Yes Evaluation Reports FL13541_R15_AE_PER2746_SS_2014-09-26.pdf Created by Independent Third Party: Yes
13541.6	F. Design Pro / Smooth Pro Fiberglass	Single with side lite(s) (X,O/ O,X/ O,X,O) Glazed Fiberglass Door, 9'-0" x 6'-8" and 9'-0" x 8'-0", Inswing and Outswing
	Limits of Use Approved for use in HVHZ: No Approved for use outside HVHZ: Yes Impact Resistant: No Design Pressure: N/A Other:	Certification Agency Certificate FL13541_R15_C_CAC_NI011923.01-R11.pdf FL13541_R15_C_CAC_NI011923-R11.pdf Quality Assurance Contract Expiration Date 03/30/2026 Installation Instructions FL13541_R15_II_13541.6.pdf Verified By: Hermes F. Norero 73778 Created by Independent Third Party: Yes Evaluation Reports FL13541_R15_AE_PER2747_SS_2014-09-26.pdf Created by Independent Third Party: Yes
13541.7	G. Design Pro / Smooth Pro / Studio Fiberglass	Double with side lite(s) (XX,O/ O,XX/ O,XX,O) Opaque Fiberglass Door, 12'-0" x 6'-8" and 12'-0" x 8'-0", Inswing and Outswing
	Limits of Use Approved for use in HVHZ: No Approved for use outside HVHZ: Yes Impact Resistant: No Design Pressure: N/A Other:	Certification Agency Certificate FL13541_R15_C_CAC_NI011911.01-R11.pdf FL13541_R15_C_CAC_NI011911-R11.pdf Quality Assurance Contract Expiration Date 03/30/2026 Installation Instructions FL13541_R15_II_A010837A_SS_2014-09-26.pdf Verified By: Hermes F. Norero 73778 Created by Independent Third Party: Yes Evaluation Reports FL13541_R15_AE_PER2748_SS_2014-09-26.pdf Created by Independent Third Party: Yes
13541.8	H. Design Pro / Smooth Pro Fiberglass	Double with side lite(s) (XX,O/ O,XX/ O,XX,O) Glazed Fiberglass Door, 12'-0" x 6'-8" and 12'-0" x 8'-0", Inswing and Outswing
	Limits of Use Approved for use in HVHZ: No Approved for use outside HVHZ: Yes Impact Resistant: No Design Pressure: N/A Other:	Certification Agency Certificate FL13541_R15_C_CAC_NI011912.01-R10.pdf FL13541_R15_C_CAC_NI011912-R10.pdf Quality Assurance Contract Expiration Date 03/30/2026 Installation Instructions FL13541_R15_II_A010838A_SS_2014-09-26.pdf Verified By: Hermes F. Norero, P.E. 73778 Created by Independent Third Party: Yes Evaluation Reports FL13541_R15_AE_PER2749_SS_2014-09-26.pdf Created by Independent Third Party: Yes

[Back](#) [Next](#)

Contact Us :: 2601 Blair Stone Road, Tallahassee FL 32399 Phone: 850-487-1824

The State of Florida is an AA/EEO employer. [Copyright 2007-2013 State of Florida](#) :: [Privacy Statement](#) :: [Accessibility Statement](#) :: [Refund Statement](#)

Under Florida law, email addresses are public records. If you do not want your e-mail address released in response to a public-records request, do not send electronic mail to this entity. Instead, contact the office by phone or by traditional mail. If you have any questions, please contact 850.487.1395. *Pursuant to Section 455.275(1), Florida Statutes, effective October 1, 2012, licensees licensed under Chapter 455, F.S. must provide the Department with an email address if they have one. The emails provided may be used for official communication with the licensee. However email addresses are public record. If you do not wish to supply a personal address, please provide the Department with an email address which can be made available to the public. To determine if you are a licensee under Chapter 455, F.S., please click [here](#).

Product Approval Accepts:



Credit Card
Safe





DESIGN PRO / SMOOTH PRO FULL LITE NON-IMPACT

FOR USE OUTSIDE THE HIGH VELOCITY HURRICANE ZONE (HVHZ)

GENERAL NOTES:

- THE PRODUCT SHOWN HEREIN IS DESIGNED AND MANUFACTURED TO COMPLY WITH THE CURRENT INTERNATIONAL BUILDING CODE (IBC), INTERNATIONAL RESIDENTIAL CODE (IRC), AND FLORIDA BUILDING CODE (FBC), EXCLUDING HVHZ AND HAS BEEN EVALUATED ACCORDING TO THE FOLLOWING:
 - ASTM E330-02
 - ASTM E283-04
 - AAMA 1304-02
 - TAS 202-94
- ADEQUACY OF THE EXISTING STRUCTURAL CONCRETE/MASONRY OR 2X FRAMING AS A MAIN WIND FORCE RESISTING SYSTEM CAPABLE OF WITHSTANDING AND TRANSFERRING APPLIED PRODUCT LOADS TO THE FOUNDATION IS THE RESPONSIBILITY OF THE ENGINEER OR ARCHITECT OF RECORD FOR THE PROJECT OF INSTALLATION.
- THE INSTALLATION DETAILS DESCRIBED HEREIN ARE GENERIC AND MAY NOT REFLECT ACTUAL CONDITIONS FOR A SPECIFIC SITE. IF SITE CONDITIONS CAUSE INSTALLATION TO DEVIATE FROM THE REQUIREMENTS DETAILED HEREIN, A LICENSED ENGINEER OR ARCHITECT SHALL PREPARE SITE SPECIFIC DOCUMENTS FOR USE WITH THIS DOCUMENT.
- APPROVED IMPACT PROTECTIVE SYSTEM IS REQUIRED ON THIS PRODUCT IN AREAS REQUIRING IMPACT RESISTANCE.
- GLASS MEETS THE REQUIREMENTS OF ASTM E 1300 GLASS CHARTS. SEE SHEET 6 FOR GLAZING DETAILS.
- FULL LITE APPROVAL COVERS USE OF FRACTIONAL GLAZING, INCLUDING INTERNAL GRID, BLINDS BETWEEN GLASS, DECORATIVE, AND EXTERNAL AND INTERNAL WROUGHT IRON. RADIUS (SHAPED) LITES ARE QUALIFIED FOR 6'-8" DOORS AT DP +/-50 PSF ONLY.
- NOTE: AFCO H-497 SILL MEETS WATER INFILTRATION AT WATER TEST PRESSURE (WTP) OF 9.0 PSF. REMAINING SILLS NOT RATED FOR WATER INFILTRATION. IF AUTHORITY HAVING JURISDICTION REQUIRES THAT PRODUCT MEETS THIS REQUIREMENT, PRODUCT SHALL BE USED WHEN INSTALLED AT LOCATION PROTECTED BY OVERHANG SUCH THAT OVERHANG (OH) RATIO = OH LENGTH ÷ OH HEIGHT IS ≥ 1.0

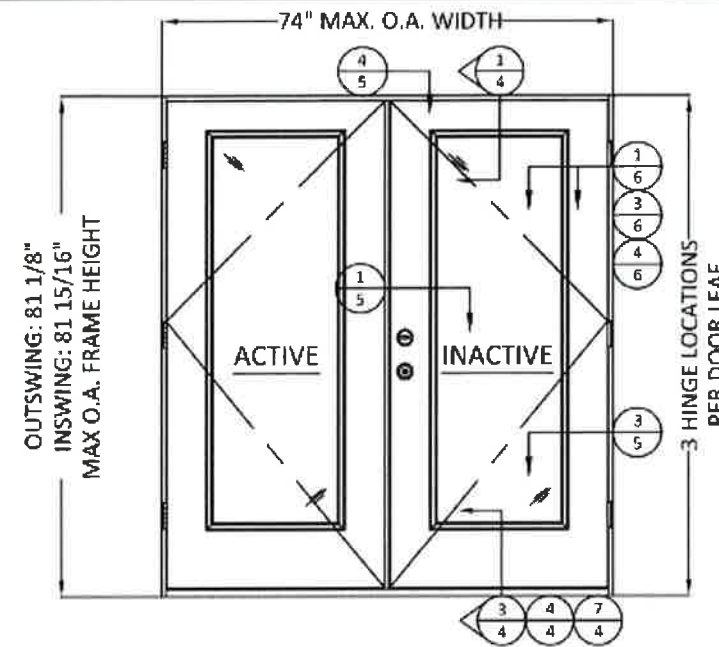

1 TYP. ELEVATION 1
6'-8" DOOR HEIGHT

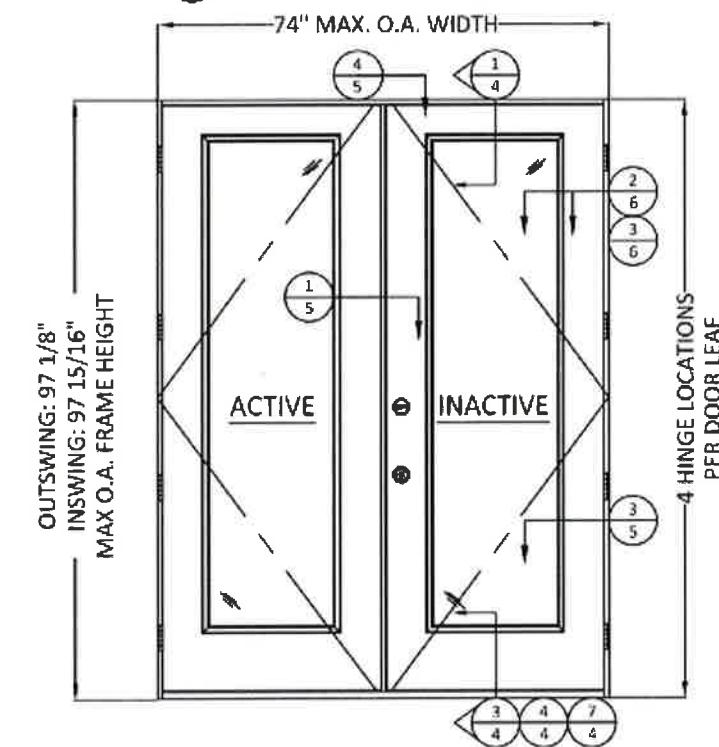

2 TYP. ELEVATION 2
8'-0" DOOR HEIGHT

NOTE:
INACTIVE AND ACTIVE DOOR PANEL
ORIENTATION IS INTERCHANGEABLE.

TABLE OF CONTENTS		
SHEET	REVISION	SHEET DESCRIPTION
1	B	TYPICAL ELEVATIONS, DESIGN PRESSURES, AND GENERAL NOTES
2	A	TYPICAL ANCHOR LAYOUTS AND NOTES
3	A	OPTIONAL 2X BUCK ANCHORING DETAILS
4	A	VERTICAL ASSEMBLIES
5	A	HORIZONTAL ASSEMBLIES
6	A	GLAZING DETAILS
7	A	WOOD SUBSTRATES
8	A	CONCRETE SUBSTRATES
9	A	COMPONENTS & BILL OF MATERIALS

CONFIGURATION	MAX. OVERALL NOMINAL SIZE		DESIGN PRESSURE (PSF)				MISSILE IMPACT RATING
	WIDTH	HEIGHT	INSWING		OUTSWING		
			POS.	NEG.	POS.	NEG.	
XX	6'-0"	6'-8"	50*	50	50*	50	NON-IMPACT
XX RADIUS	6'-0"	6'-8"	50*	50	50*	50	NON-IMPACT
XX	6'-0"	8'-0"	50*	50	50*	50	NON-IMPACT

*SEE GENERAL NOTE 7, SHEET 1, FOR WATER INFILTRATION APPROVED SILLS.

PREPARED BY:



BUILDING DROPS, INC.
398 E. DANIA BEACH BLVD., STE. 338
DANIA BEACH, FL 33004
PH: (954)399-8478
FAX: (954)744-4738
WEB: www.buildingdrops.com

TITLE: DESIGN PRO/SMOOTH PRO FULL LITE
NON-IMPACT
TYPICAL ELEVATIONS, DESIGN PRESSURES, AND GENERAL NOTES

3737 LAKEPORT BLVD.,
KLAMATH FALLS, OR 97601
PH: (541)882-3451
FAX: (541)850-2609



REMARKS	BY	DATE
Add Multi-Point Lock	GL	06/12/14
Add TAS 202-94 Standard	SM	09/22/14

THIS DOCUMENT IS THE PROPERTY OF BUILDING DROPS, INC. AND SHALL NOT BE REPRODUCED IN WHOLE OR PART WITHOUT WRITTEN CONSENT OF BUILDING DROPS, INC. ALTERATIONS, ADDITIONS, HIGHLIGHTING, OR OTHER MARKINGS TO THIS DOCUMENT ARE NOT PERMITTED AND INVALID.



Digitally signed by Hermes F. Norero, P.E.
Reason: I am approving this document
Date: 2014.09.26 14:55:17 -04'00'

DATE: 02.05.14
DWG. BY: GL/TJM
CHK. BY: SS/MSS
SCALE: NTS
DWG. #: A010834A
SHEET: 1 OF 9

INSTALLATION NOTES:

- ONE (1) INSTALLATION ANCHOR IS REQUIRED AT EACH ANCHOR LOCATION SHOWN.
- SHIM AS REQUIRED AT EACH INSTALLATION ANCHOR WITH LOAD BEARING SHIM(S). MAXIMUM ALLOWABLE SHIM STACK TO BE 1/4 INCH. SHIM WHERE SPACE OF 1/16 INCH OR GREATER OCCURS. SHIM(S) SHALL BE A NON-COMPRESSIBLE COMPOSITE OR BETTER.
- MINIMUM EMBEDMENT AND EDGE DISTANCE EXCLUDE WALL FINISHES, INCLUDING BUT NOT LIMITED TO STUCCO, FOAM, BRICK VENEER, AND SIDING.
- INSTALLATION ANCHORS AND ASSOCIATED HARDWARE MUST BE MADE OF CORROSION RESISTANT MATERIAL OR HAVE A CORROSION RESISTANT COATING, AND SHALL BE INSTALLED IN ACCORDANCE WITH ANCHOR MANUFACTURER'S INSTALLATION INSTRUCTIONS.
- FOR HOLLOW BLOCK AND GROUT FILLED BLOCK, DO NOT INSTALL INSTALLATION ANCHORS INTO MORTAR JOINTS. EDGE DISTANCE IS MEASURED FROM FREE EDGE OF BLOCK OR EDGE OF MORTAR JOINT INTO FACE SHELL OF BLOCK.
- FOR 2X STUD CONSTRUCTION, ANCHORING OF THESE PRODUCTS SHALL BE THE SAME AS FOR 2X BUCK CONCRETE/MASONRY CONSTRUCTION.
- INSTALLATION ANCHOR CAPACITIES FOR PRODUCTS HEREIN ARE BASED ON SUBSTRATE MATERIALS WITH THE FOLLOWING PROPERTIES:
 - WOOD - MINIMUM SPECIFIC GRAVITY OF 0.55.
 - CONCRETE - MINIMUM COMPRESSIVE STRENGTH OF 3000 PSI.
 - GROUT-FILLED CMU - UNIT STRENGTH CONFORMS TO ASTM C-90 WITH MINIMUM COMPRESSIVE STRENGTH OF 2000 PSI AND GROUT CONFORMS TO ASTM C 476, MINIMUM GROUT COMPRESSIVE STRENGTH OF 2000 PSI.
 - HOLLOW BLOCK CMU - UNIT STRENGTH CONFORMS TO ASTM C-90 WITH MINIMUM COMPRESSIVE STRENGTH OF 2000 PSI.
- SEE SHEETS 7 AND 8 FOR MORE DETAILS OF THE INSTALLATION REQUIREMENTS, INCLUDING ANCHOR LOCATIONS, EDGE DISTANCES, EMBEDMENTS, AND SHIM SPACING.
- OPTIONALLY, ANCHORS CAN BE PLACED IN NARROW SECTION OF HEAD OR JAMB AS LONG AS MINIMUM EMBEDMENT AND EDGE DISTANCE ARE ACHIEVED.

PREPARED BY:

BUILDING DROPS, INC.
 398 E. DANIA BEACH BLVD., STE. 338
 DANIA BEACH, FL 33034
 PH: (954)399-8478
 FAX: (954)744-4738
 WEB: www.buildingdrops.com

TITLE: DESIGN PRO/SMOOTH PRO FULL LITE
NON-IMPACT

ANCHOR LAYOUTS AND NOTES

3737 LAKEPORT BLVD.,
 KLAMATH FALLS, OR 97601
 PH: (541)882-3451
 FAX: (541)850-2609

JELD-WEN
 WINDOWS & DOORS

REMARKS	BY	DATE
Add Multi-Point Lock	GL	06/12/14

THIS DOCUMENT IS THE PROPERTY OF BUILDING DROPS, INC. AND SHALL NOT BE REPRODUCED IN WHOLE OR PART WITHOUT WRITTEN CONSENT OF BUILDING DROPS, INC. ALTERATIONS, ADDITIONS, HIGHLIGHTING, OR OTHER MARKINGS TO THIS DOCUMENT ARE NOT PERMITTED AND INVALID.

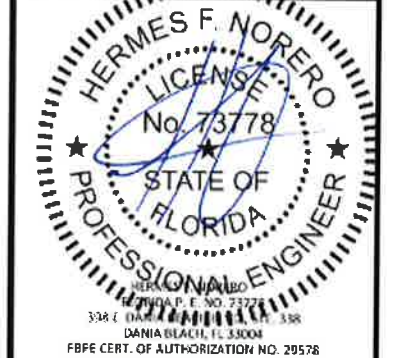

DATE: 02.05.14
 DWG. BY: GL/TJM
 CHK. BY: SS/MSS
 SCALE: NTS
 DWG. #: A010834A
 SHEET: OF 9

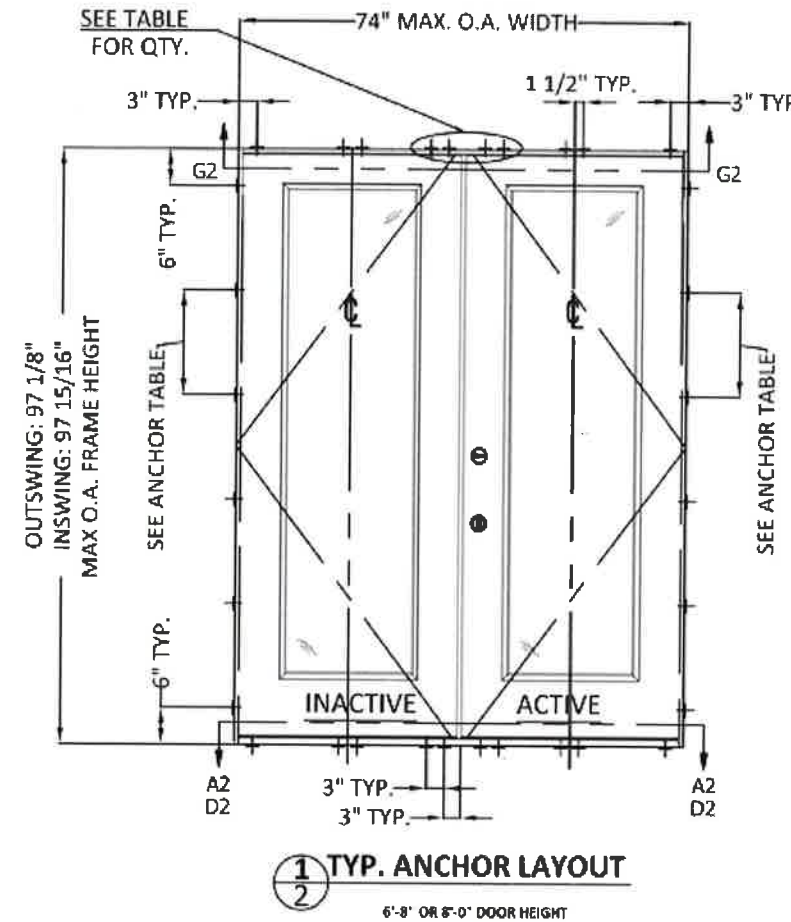

NOTE:
 INACTIVE AND ACTIVE DOOR PANEL ORIENTATION IS INTERCHANGEABLE.

ANCHOR TABLE																																							
ANCHOR TYPE	ANCHOR SIZE	SUBSTRATE	MIN. EMBEDMENT	MIN. EDGE DISTANCE	6'8\"/>																																		
					MAX. O.C. SPACING AT JAMBS	# OF ANCHORS AT HEAD/SILL CLUSTERS	8'0\"/> <tbody> <tr> <td>WOOD SCREW</td> <td>#10</td> <td>2X WOOD BUCK OR FRAMING</td> <td>1-1/2"</td> <td>3/4"</td> <td>17-1/2"</td> <td>4</td> <td>17-1/4"</td> <td>4</td> </tr> <tr> <td>ITW TAPCON</td> <td>3/16"</td> <td>CONCRETE/CMU</td> <td>1-1/4"</td> <td>2-1/2"</td> <td>17-1/2"</td> <td>4</td> <td>17-1/4"</td> <td>4</td> </tr> <tr> <td>ELCO ULTRACON</td> <td>1/4"</td> <td>CONCRETE/CMU</td> <td>1-3/8" - CONC. 1-1/4" - CMU</td> <td>1"</td> <td>17-1/2"</td> <td>4</td> <td>17-1/4"</td> <td>4</td> </tr> <tr> <td>ITW TAPCON</td> <td>3/16"</td> <td>CONCRETE/CMU</td> <td>1-1/4"</td> <td>1"</td> <td>11-5/8"</td> <td>8</td> <td>14-3/8"</td> <td>6</td> </tr> </tbody>		WOOD SCREW	#10	2X WOOD BUCK OR FRAMING	1-1/2"	3/4"	17-1/2"	4	17-1/4"	4	ITW TAPCON	3/16"	CONCRETE/CMU	1-1/4"	2-1/2"	17-1/2"	4	17-1/4"	4	ELCO ULTRACON	1/4"	CONCRETE/CMU	1-3/8" - CONC. 1-1/4" - CMU	1"	17-1/2"	4	17-1/4"	4	ITW TAPCON	3/16"	CONCRETE/CMU	1-1/4"
WOOD SCREW	#10	2X WOOD BUCK OR FRAMING	1-1/2"	3/4"	17-1/2"	4	17-1/4"	4																															
ITW TAPCON	3/16"	CONCRETE/CMU	1-1/4"	2-1/2"	17-1/2"	4	17-1/4"	4																															
ELCO ULTRACON	1/4"	CONCRETE/CMU	1-3/8" - CONC. 1-1/4" - CMU	1"	17-1/2"	4	17-1/4"	4																															
ITW TAPCON	3/16"	CONCRETE/CMU	1-1/4"	1"	11-5/8"	8	14-3/8"	6																															

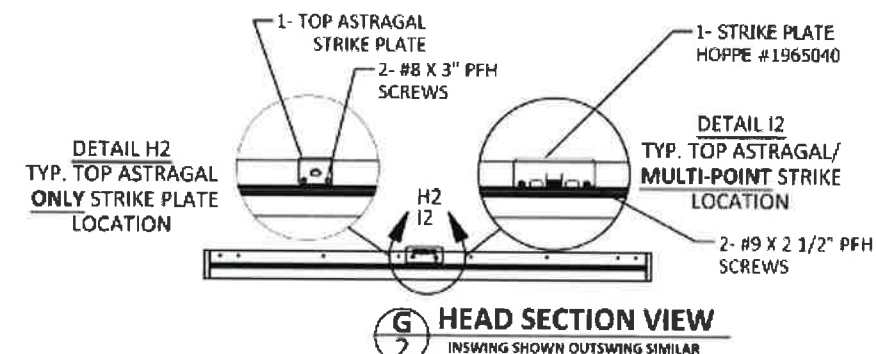
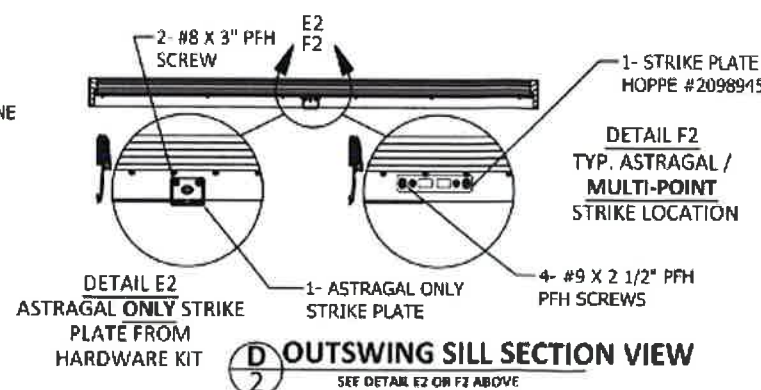
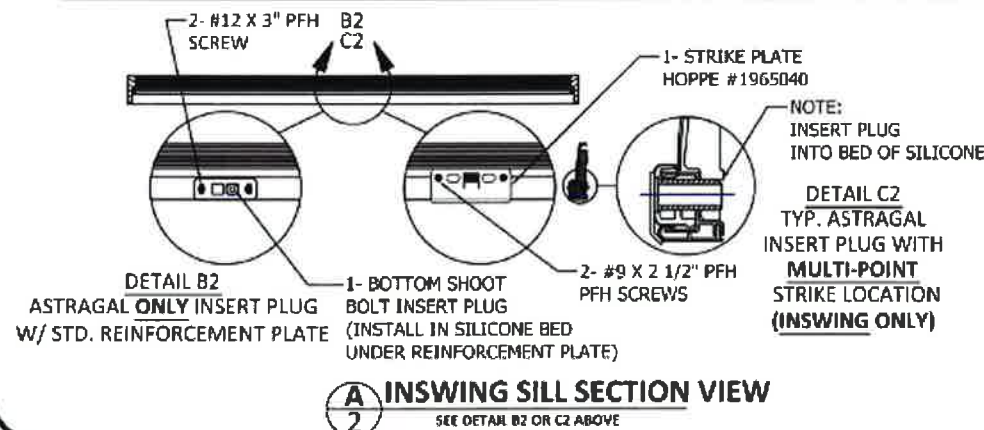

PREPARED BY:



BUILDING DROPS, INC.
 298 E. DANIA BEACH BLVD., STE. 338
 DANIA BEACH, FL 33004
 PH: (954)399-8478
 FAX: (954)744-4738
 WEB: www.buildingdrops.com

TITLE: DESIGN PRO/SMOOTH PRO FULL LITE
 NON-IMPACT
 OPTIONAL 2X BUCK
 ANCHORING DETAILS

3737 LAKEPORT BLVD.,
 KLAMATH FALLS, OR 97601
 PH: (541)882-3451
 FAX: (541)850-2609

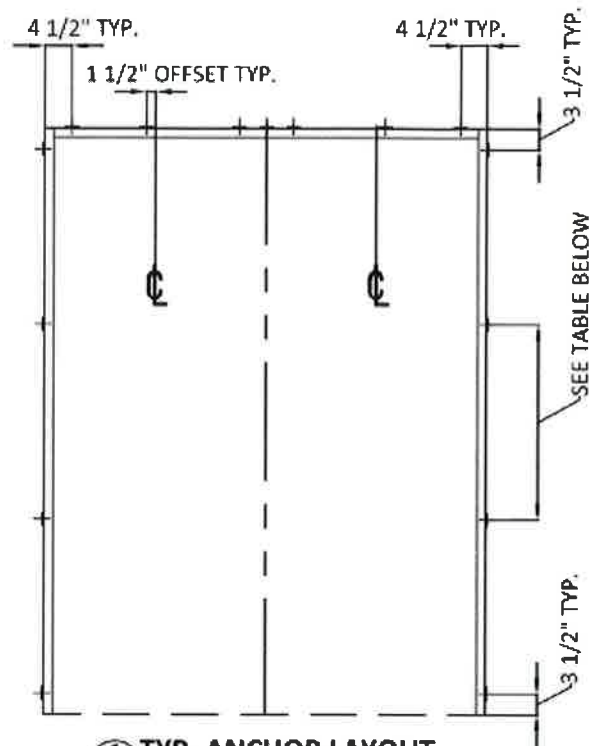

1 TYP. ANCHOR LAYOUT
 3 OPTIONAL 2X BUCK IN CONCRETE/MASONRY

REMARKS	BY	DATE
Add Multi-Point Lock	GL	06/12/14

THIS DOCUMENT IS THE PROPERTY OF BUILDING DROPS, INC. AND SHALL NOT BE REPRODUCED IN WHOLE OR PART WITHOUT WRITTEN CONSENT OF BUILDING DROPS, INC. ALTERATIONS, ADDITIONS, HIGHLIGHTING, OR OTHER MARKINGS TO THIS DOCUMENT ARE NOT PERMITTED AND INVALID.

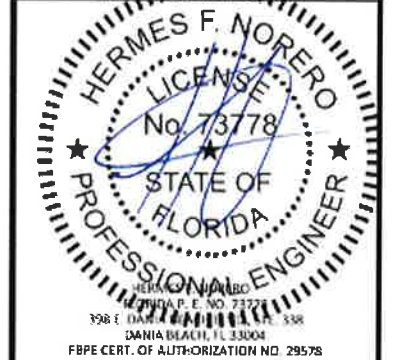

DATE: 02.05.14
 DWG. BY: GL/TJM CHK. BY: SS/MSS
 SCALE: NTS
 DWG. #: A010834A
 SHEET: OF 9

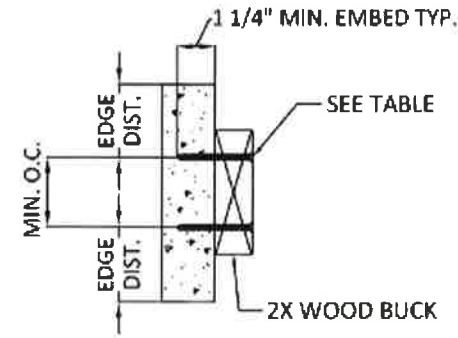

3 2X WOOD BUCK INSTALL.
 CROSS SECTION

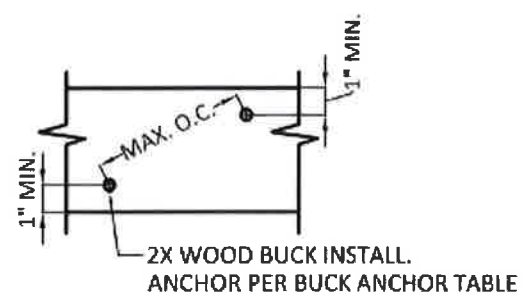

4 2X WOOD BUCK INSTALL.
 SIDE VIEW

2X BUCK ANCHOR TABLE							
ANCHOR TYPE	ANCHOR SIZE	SUBSTRATE	MIN. EMBEDMENT	MIN. EDGE DIST. TO SUBSTRATE	MIN. CENTER TO CENTER DISTANCE	6'8" DOORS	8'0" DOORS
						MAX. O.C. SPACING AT JAMBS	MAX. O.C. SPACING AT JAMBS
ITW TAPCON	1/4"	CONCRETE/CMU	1-1/4"	2-1/2"	4"	25"	30-1/4"
ELCO ULTRACON	1/4"	CONCRETE/CMU	1-3/8" - CONC. 1-1/4" - CMU	1"	4"	25"	30-1/4"

NOTES:

1. 2X BUCK IS NOT FOR INSTALLATION AT SILL. THRESHOLD SHALL BE FASTENED IN ACCORDANCE WITH ANCHOR LOCATIONS SHOWN ON SHEET 2.
2. ANCHORS MAY BE STAGGERED AS SHOWN IN DETAIL 4/3.

PREPARED BY:



BUILDING DROPS, INC.
398 E. DANIA BEACH BLVD., STE. 338
DANIA BEACH, FL 33004
PH: (954)399-8478
FAX: (954)744-4738
WEB: www.buildingdrops.com

TITLE: DESIGN PRO/SMOOTH PRO FULL LITE
NON-IMPACT

VERTICAL ASSEMBLIES

3737 LAKEPORT BLVD.,
KLAMATH FALLS, OR 97601
PH: (541)882-3451
FAX: (541)850-2609

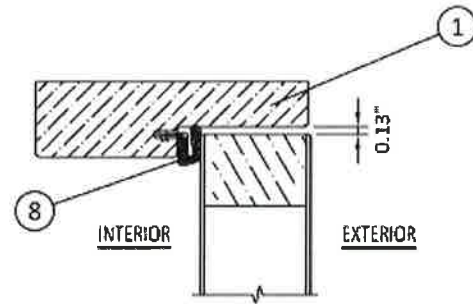

1
4 OPERABLE HEAD
OUTSWING SHOWN - INSWING SIMILAR

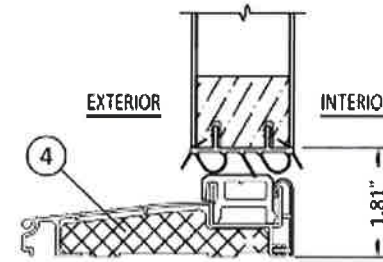

3
4 OPERABLE SILL
INSWING
ENDURA ZAIL4565F

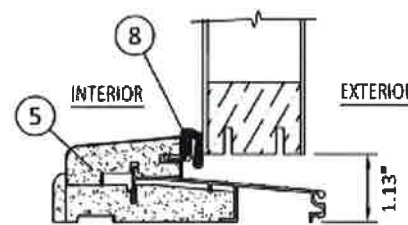

4
4 OPERABLE SILL
OUTSWING
AFCO J-2297

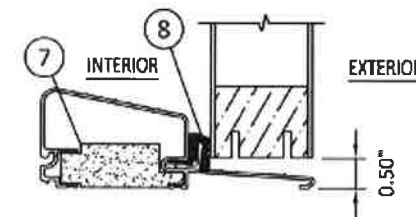

7
4 OPERABLE SILL
OUTSWING
OPTIONAL AFCO H-497

REMARKS	BY	DATE
Add Multi-Point Lock	GL	06/12/14

THIS DOCUMENT IS THE PROPERTY OF BUILDING DROPS, INC. AND SHALL NOT BE REPRODUCED IN WHOLE OR PART WITHOUT WRITTEN CONSENT OF BUILDING DROPS, INC. ALTERATIONS, ADDITIONS, HIGHLIGHTING, OR OTHER MARKINGS TO THIS DOCUMENT ARE NOT PERMITTED AND INVALID.

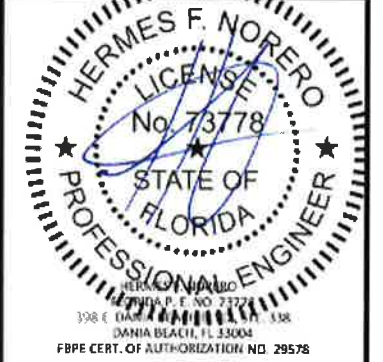

DATE: 02.05.14
 DWG. BY: GL/TJM CHK. BY: SS/MSS
 SCALE: NTS
 DWG. #: A010834A
 SHEET: OF 9

HINGE SCHEDULE	
DOOR HEIGHT	QUANTITY
6'-8"	3
8'-0"	4

HINGE DETAIL AT JAMB:
PLACE #9 X 2-1/2" PFH SCREW NEXT TO WEATHERSTRIP

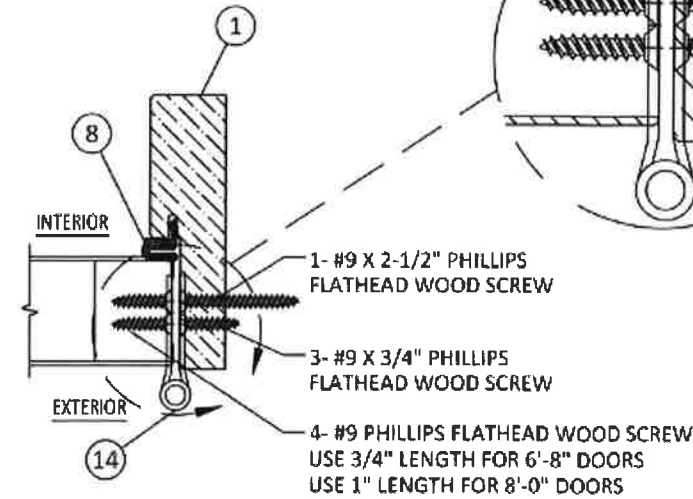
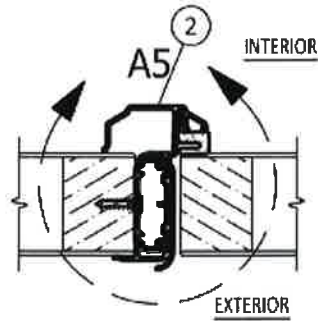
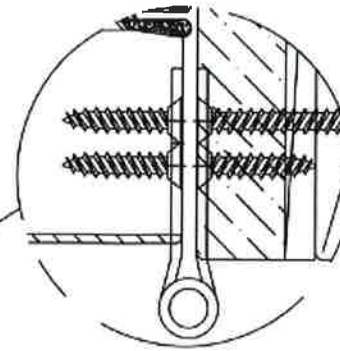

1
5 MEETING STILE
OUTSWING SHOWN - INSWING SIMILAR

3
5 HINGE JAMB
OUTSWING SHOWN - INSWING SIMILAR

- 1- #9 X 2-1/2" PHILLIPS FLATHEAD WOOD SCREW
- 3- #9 X 3/4" PHILLIPS FLATHEAD WOOD SCREW
- 4- #9 PHILLIPS FLATHEAD WOOD SCREW
USE 3/4" LENGTH FOR 6'-8" DOORS
USE 1" LENGTH FOR 8'-0" DOORS

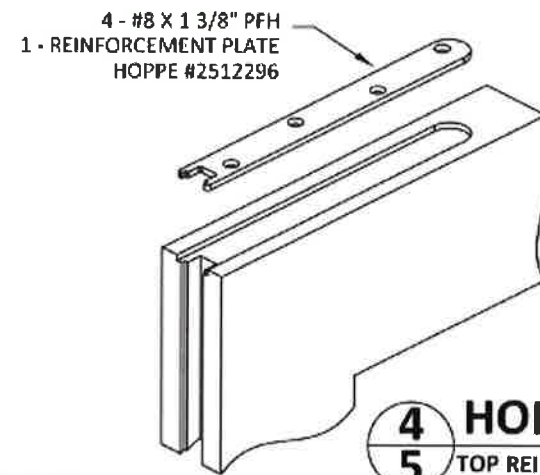
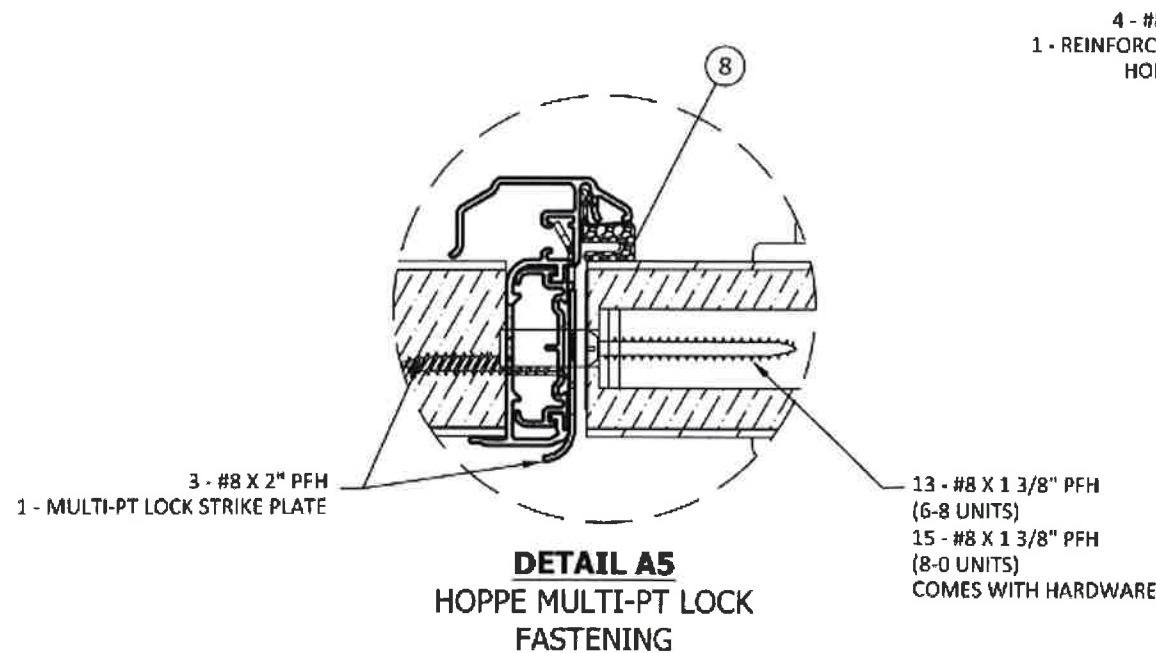

4
5 HOPPE MULTI-POINT LOCK
TOP REINFORCEMENT PLATE - ACTIVE PANEL ONLY

- 3 - #8 X 2" PFH
1 - MULTI-PT LOCK STRIKE PLATE
- 13 - #8 X 1 3/8" PFH (6-8 UNITS)
15 - #8 X 1 3/8" PFH (8-0 UNITS)
COMES WITH HARDWARE

DETAIL A5
HOPPE MULTI-PT LOCK
FASTENING

PREPARED BY:

BUILDING DROPS, INC.
398 E. DANIA BEACH BLVD., STE. 338
DANIA BEACH, FL 33034
PH: (954)399-8478
FAX: (954)744-4738
WEB: www.buildingdrops.com

TITLE: DESIGN PRO/SMOOTH PRO FULL LITE
NON-IMPACT
HORIZONTAL ASSEMBLIES

3737 LAKEPORT BLVD.,
KLAMATH FALLS, OR 97601
PH: (541)882-3451
FAX: (541)850-2609

JELDWEN
WINDOWS & DOORS

REMARKS	BY	DATE
Add Multi-Point Lock	GL	06/12/14

THIS DOCUMENT IS THE PROPERTY OF BUILDING DROPS, INC. AND SHALL NOT BE REPRODUCED IN WHOLE OR PART WITHOUT WRITTEN CONSENT OF BUILDING DROPS, INC. ALTERATIONS, ADDITIONS, HIGHLIGHTING, OR OTHER MARKINGS TO THIS DOCUMENT ARE NOT PERMITTED AND INVALID.



HERMES F. NORERO
P.E. NO. 73778
398 E. DANIA BEACH BLVD., STE. 338
DANIA BEACH, FL 33034
FBPE CERT. OF AUTHORIZATION NO. 29578

DATE: 02.05.14
DWG. BY: GL/TJM
CHK. BY: SS/MSS
SCALE: NTS
DWG. #: A010834A
SHEET: OF 9

PREPARED BY:



BUILDING DROPS, INC.

398 E. DANIA BEACH BLVD., STE. 338
DANIA BEACH, FL 33004
PH: (954)399-8478
FAX: (954)744-4738
WEB: www.buildingdrops.com

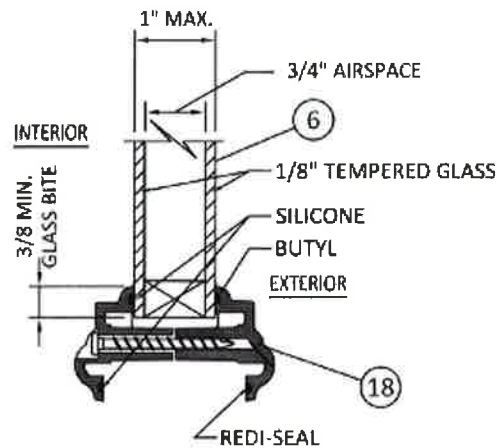

1 **6'-8" GLAZING DETAIL**
6

20 1/2" MAX. D.L.O. WIDTH
62 1/2" MAX. D.L.O. HEIGHT

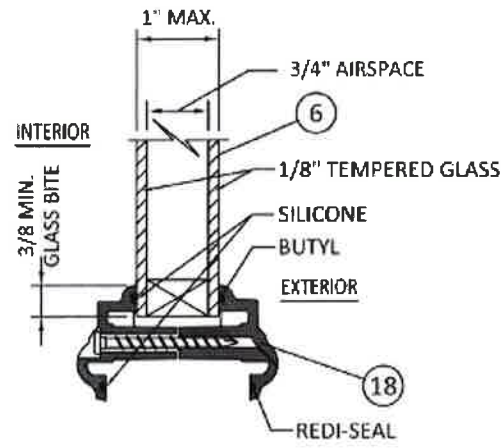

2 **8'-0" GLAZING DETAIL**
6

20 1/2" MAX. D.L.O. WIDTH
78 1/2" MAX. D.L.O. HEIGHT

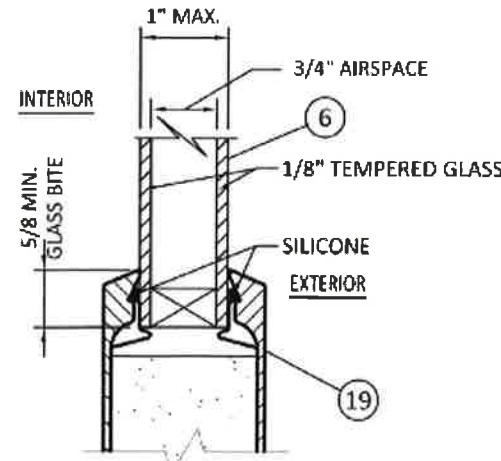

3 **FLUSH GLAZE DETAIL**
6

23 7/8" MAX. D.L.O. WIDTH
78 7/8" MAX. D.L.O. HEIGHT

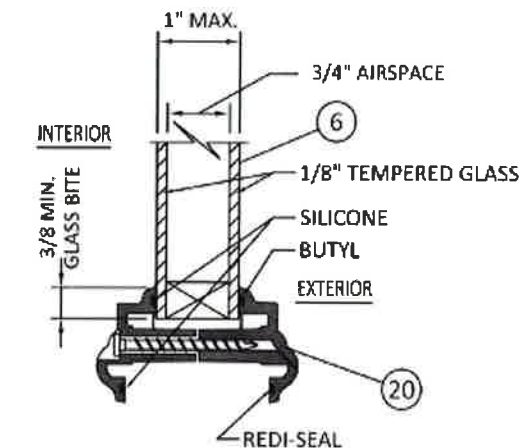

4 **GLAZING DETAIL**
6

FOR OVAL, SUNBURST, AND ROUND TOPS
ONLY IN 6'8" UNITS AT DP+/- 50 PSF

TITLE: DESIGN PRO/SMOOTH PRO FULL LITE
NON-IMPACT
GLAZING DETAILS

3737 LAKEPORT BLVD.,
KLAMATH FALLS, OR 97601
PH: (541)882-3451
FAX: (541)850-2609



REMARKS	BY	DATE
Add Multi-Point Lock	GL	06/12/14

THIS DOCUMENT IS THE PROPERTY OF BUILDING DROPS, INC. AND SHALL NOT BE REPRODUCED IN WHOLE OR PART WITHOUT WRITTEN CONSENT OF BUILDING DROPS, INC. ALTERATIONS, ADDITIONS, HIGHLIGHTING, OR OTHER MARKINGS TO THIS DOCUMENT ARE NOT PERMITTED AND INVALID.

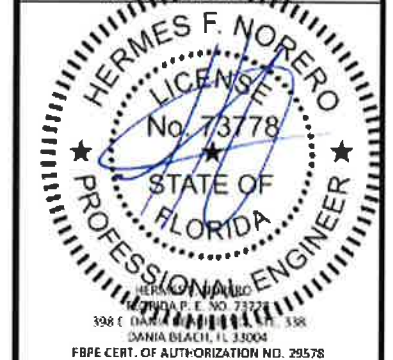

DATE: 02.05.14
DWG. BY: GL/TJM | CHK. BY: SS/MSS
SCALE: NTS
DWG. #: A010834A
SHEET: OF 9

NOTE:
FRACTIONAL GLAZING, INCLUDING INTERNAL GRID, BLINDS BETWEEN GLASS, DECORATIVE, EXTERNAL AND INTERNAL WROUGHT IRON AND RADIUS (SHAPED) LITES ARE APPROVED IN ALL GLAZING DETAILS SHOWN ABOVE.

PREPARED BY:



BUILDING DROPS, INC.

398 E. DANIA BEACH BLVD., STE. 398
 DANIA BEACH, FL 33004
 PH: (954) 399-8478
 FAX: (954) 744-4738
 WEB: www.buildingdrops.com

TITLE: DESIGN PRO/SMOOTH PRO FULL LITE
 NON-IMPACT
 WOOD INSTALLATION

3737 LAKEPORT BLVD.,
 KLAMATH FALLS, OR 97601
 PH: (541) 882-3451
 FAX: (541) 850-2609

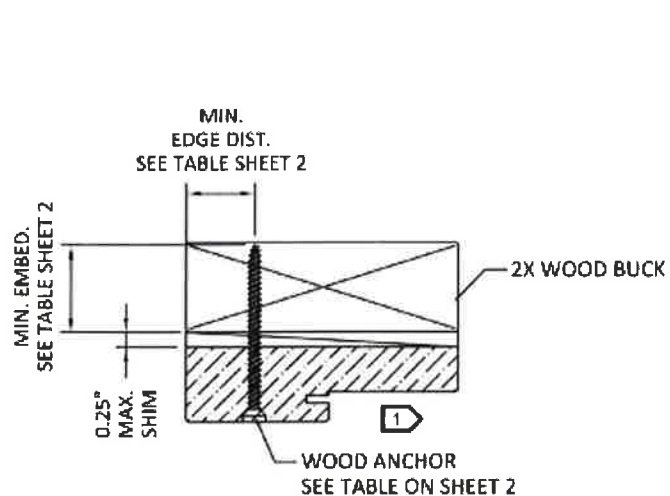

1
7 HEAD (TYPICAL)
 OUTSWING SHOWN - INSWING SIMILAR

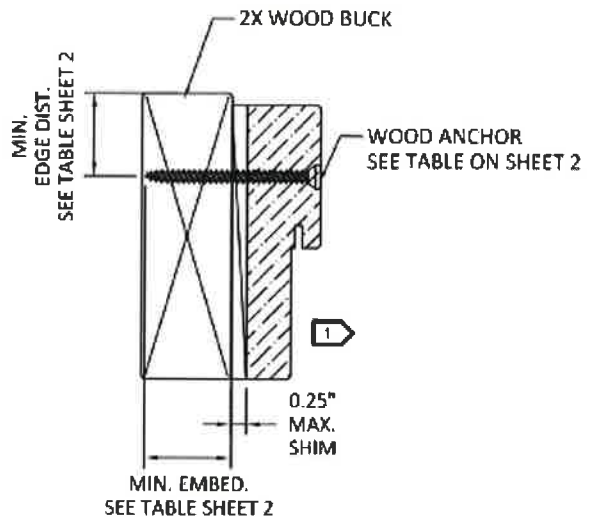

2
7 JAMB (TYPICAL)
 OUTSWING SHOWN - INSWING SIMILAR

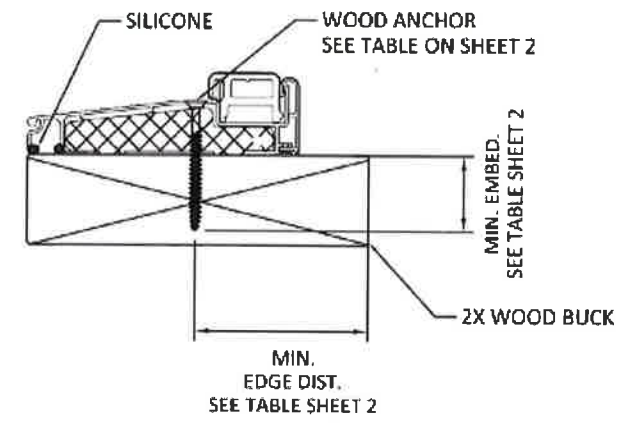

3
7 OPERABLE SILL
 INSWING
 ENDURA ZAIL4565F

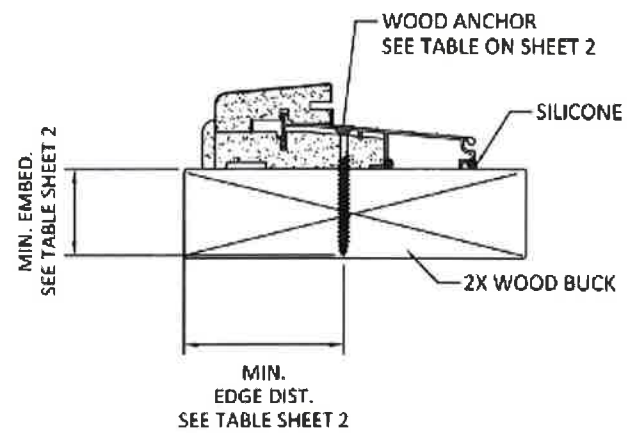

4
7 OPERABLE SILL
 OUTSWING
 AFCD J-2297

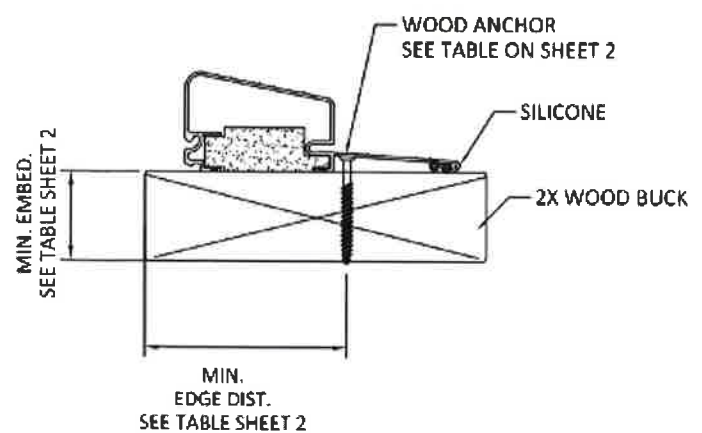

7
7 OPERABLE SILL
 HIGH BUMP OUTSWING
 AFCD H-497

1 OPTIONALLY, ANCHOR CAN BE PLACED IN NARROW SECTION OF HEAD OR JAMB AS LONG AS MINIMUM EMBEDMENT AND EDGE DISTANCE ARE ACHIEVED.

REMARKS	BY	DATE
Add Multi-Point Lock	GL	06/12/14

THIS DOCUMENT IS THE PROPERTY OF BUILDING DROPS, INC. AND SHALL NOT BE REPRODUCED IN WHOLE OR PART WITHOUT WRITTEN CONSENT OF BUILDING DROPS, INC. ALTERATIONS, ADDITIONS, HIGHLIGHTING, OR OTHER MARKINGS TO THIS DOCUMENT ARE NOT PERMITTED AND INVALIDATION.

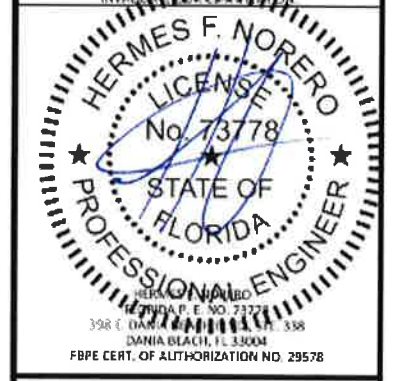

HERMES F. NORERO
 LICENSE NO. 73778
 STATE OF FLORIDA
 PROFESSIONAL ENGINEER
 398 E. DANIA BEACH BLVD., STE. 398
 DANIA BEACH, FL 33004
 FBPE CERT. OF AUTHORIZATION NO. 29578

DATE:	02.05.14
DWG. BY:	GL/TJM
CHK. BY:	SS/MSS
SCALE:	NTS
DWG. #:	A010834A
SHEET:	7 OF 9

PREPARED BY:



BUILDING DROPS, INC.
 398 E. DANIA BEACH BLVD., STE. 338
 DANIA BEACH, FL 33004
 PH: (954)399-8478
 FAX: (954)744-4738
 WEB: www.buildingdrops.com

TITLE: DESIGN PRO/SMOOTH PRO FULL LITE
 NON-IMPACT

CONCRETE INSTALLATION

3737 LAKEPORT BLVD.,
 KLAMATH FALLS, OR 97601
 PH: (541)862-3451
 FAX: (541)850-2609



REMARKS	BY	DATE
Add Multi-Point Lock	GL	06/12/14

THIS DOCUMENT IS THE PROPERTY OF BUILDING DROPS, INC. AND SHALL NOT BE REPRODUCED IN WHOLE OR PART WITHOUT WRITTEN CONSENT OF BUILDING DROPS, INC. ALTERATIONS, ADDITIONS, HIGHLIGHTING, OR OTHER MARKINGS TO THIS DOCUMENT ARE NOT PERMITTED AND INVALIDATION.

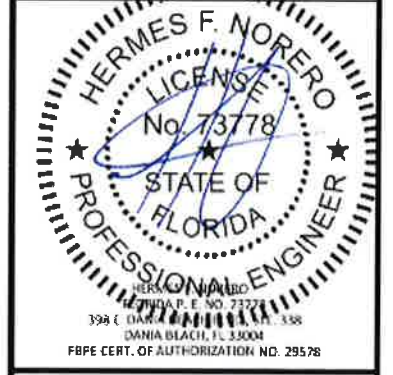

HERMES F. NORERO
 LICENSE No. 73778
 STATE OF FLORIDA
 PROFESSIONAL ENGINEER
 398 E. DANIA BEACH BLVD., STE. 338
 DANIA BEACH, FL 33004
 FBPE CERT. OF AUTHORIZATION NO. 29578

DATE:	02.05.14
DWG. BY:	GL/TJM
CHK. BY:	SS/MSS
SCALE:	NTS
DWG. #:	A010834A
SHEET:	OF 9

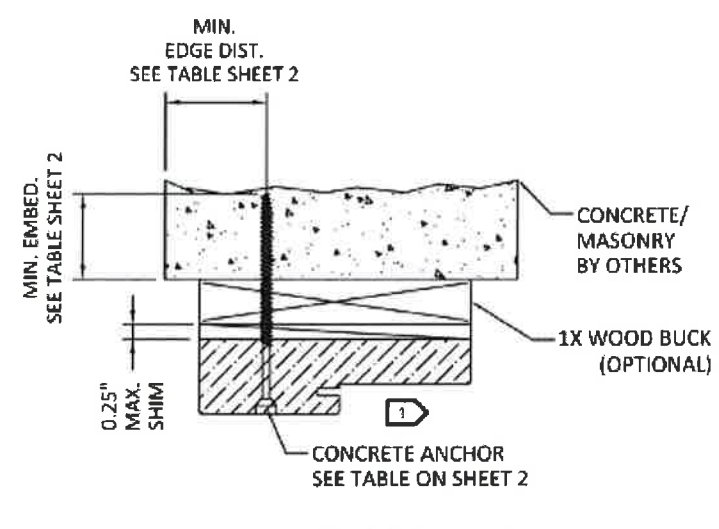

1
8 HEAD (TYPICAL)
 OUTSWING SHOWN - INSWING SIMILAR

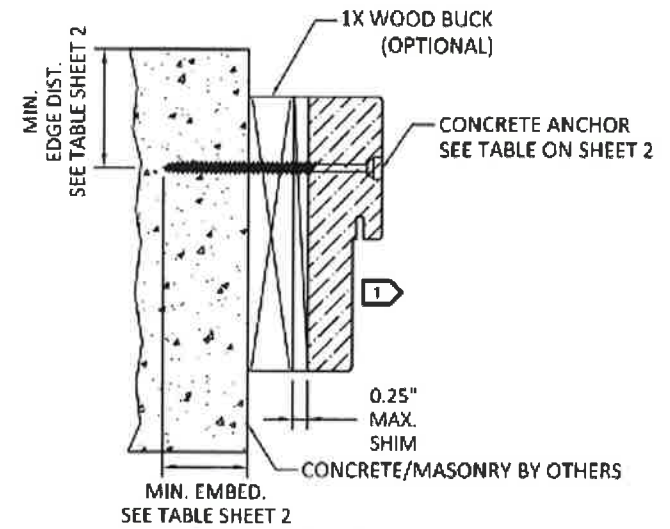

2
8 JAMB (TYPICAL)
 OUTSWING SHOWN - INSWING SIMILAR

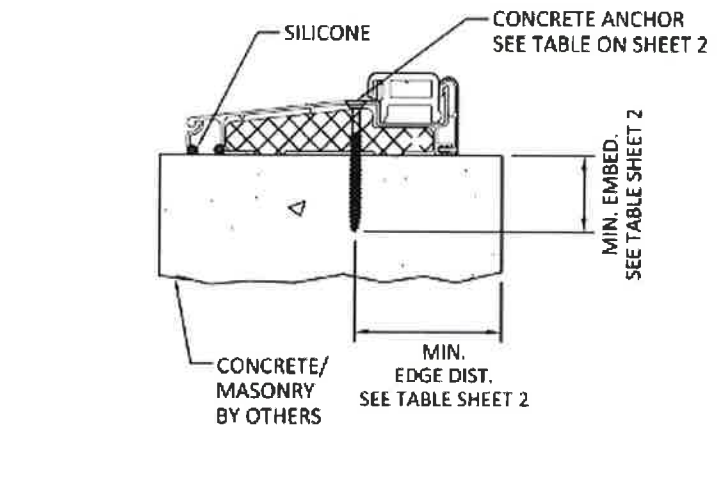

3
8 OPERABLE SILL
 INSWING
 ENDURA ZAIL4565F

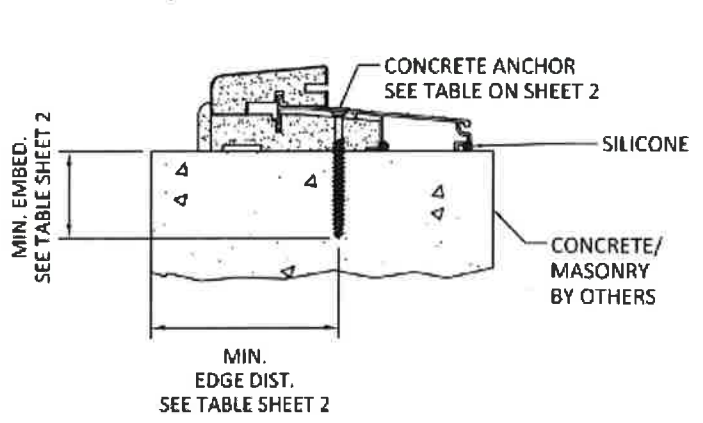

4
8 OPERABLE SILL
 OUTSWING
 AFCO I-2297

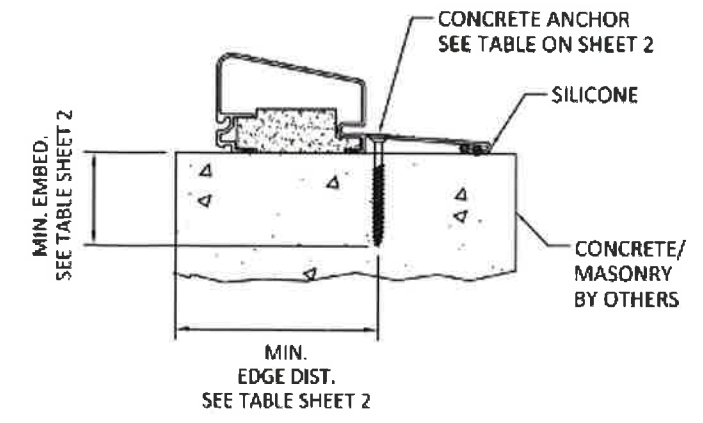

7
8 OPERABLE SILL
 HIGH BUMP OUTSWING
 AFCO H-497

1 OPTIONALLY, ANCHOR CAN BE PLACED IN NARROW SECTION OF HEAD OR JAMB AS LONG AS MINIMUM EMBEDMENT AND EDGE DISTANCE ARE ACHIEVED.

BILL OF MATERIALS		
ITEM#	DESCRIPTION	MATERIAL
1	FRAME HEAD/JAMBS	FINGER-JOINTED PINE
		SOLID PINE
		LAMINATED VENEER LUMBER
		COMPOSITE
2	ASTRAGAL, ENDURA ULTIMATE HURRICANE (SEE SHEET 2 FOR HARDWARE AND FASTENING DETAILS)	6063-T6 ALUMINUM
3	(NOT USED)	-
4	ENDURA ZAIL4565F THRESHOLD	-
5	AFCO J-2297 THRESHOLD	-
6	1" O.A. IG TEMPERED NON-IMPACT GLASS	-
7	AFCO H-497 THRESHOLD	-
8	WEATHERSTRIP	URETHANE FOAM & POLYETHYLENE
9	NON-COMPRESSION SHIM (0.25" MAX. THK.)	COMPOSITE
10	2X WOOD (S.G. MUST BE 0.55 OR GREATER)	WOOD
11	1X WOOD (S.G. MUST BE 0.55 OR GREATER)	WOOD
12	#10 WOOD INSTALLATION SCREW W/ 1 1/2" MIN. EMBEDMENT	STEEL
13	CONC./CMU ANCHOR (SEE ANCHOR TABLE SHEETS 2 & 3)	STEEL
14	BUTT HINGE (SEE SCHEDULE SHEET 5)	-
15	KWIKSET LOCK SERIES 400	STEEL
16	KWIKSET DEADBOLT SERIES 780	STEEL
17	HOPPE MULTI-POINT HARDWARE HLS9000 (SEE SHEET 2 FOR HARDWARE AND FASTENING DETAILS)	STEEL
18	ODL LIPLITE KIT (NI)	PLASTIC
19	FLUSH GLAZING LEG	FIBERGLASS
20	ODL LIPLITE KIT (RADIUS LITES)	PLASTIC

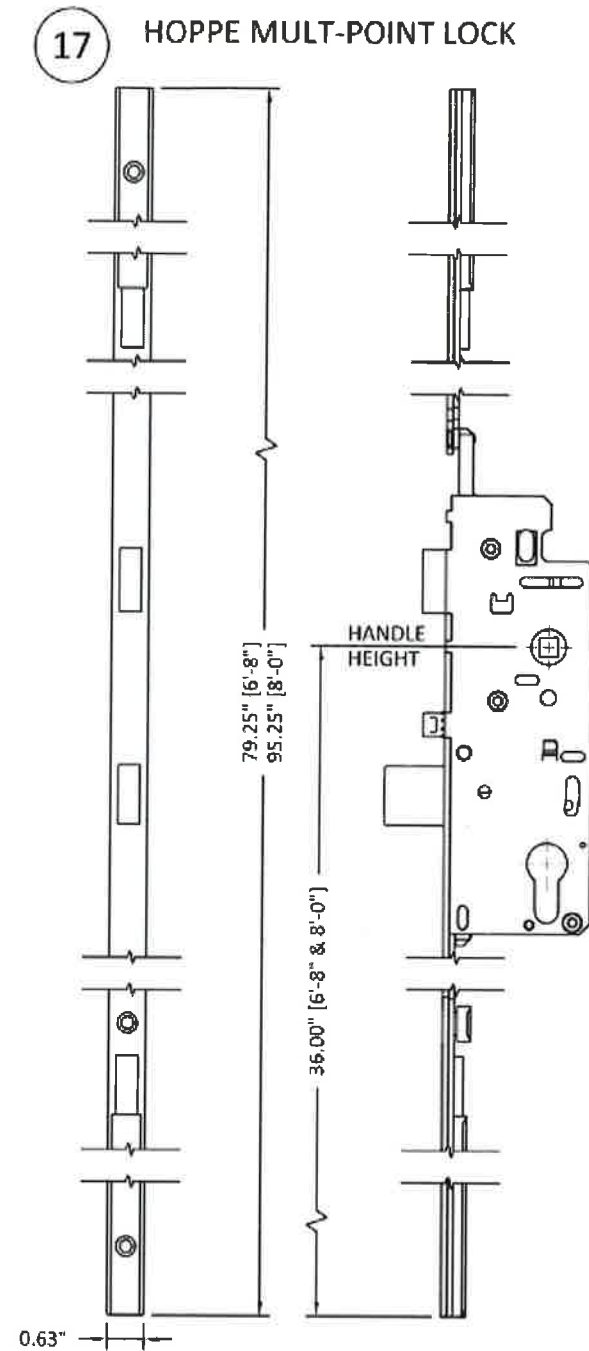

1 FRAME HEAD/JAMBS
VARIES, SEE BOM ABOVE

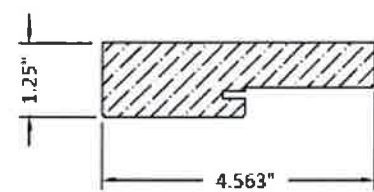

2 ENDURA ASTRAGAL
ALUMINUM

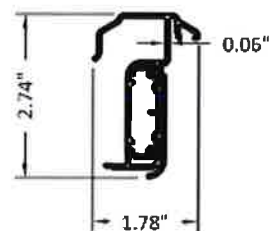

4 ENDURA ZAIL4565F THRESHOLD

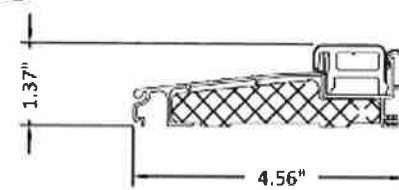

5 AFCO J-2297 THRESHOLD

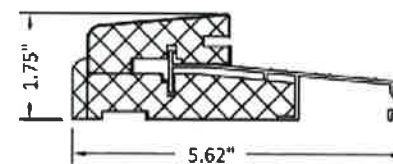

7 AFCO H-497 THRESHOLD

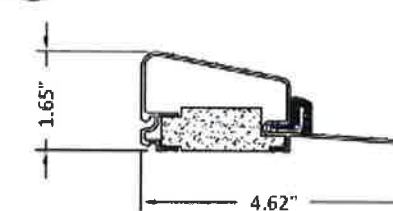

PREPARED BY:



BUILDING DROPS, INC.

398 L. DANIA BEACH BLVD., STE. 338
DANIA BEACH, FL 33004
PH: (954) 999-8478
FAX: (954) 744-4738
WEB: www.buildingdrops.com

TITLE: DESIGN PRO/SMOOTH PRO FULL LITE
NON-IMPACT

COMPONENTS AND BILL OF MATERIALS

3737 LAKEPORT BLVD.,
KLAMATH FALLS, OR 97601
PH: (541) 882-3451
FAX: (541) 850-2609

JELD-WEN
WINDOWS & DOORS

REMARKS	BY	DATE
Add Multi-Point Lock	GL	06/12/14

THIS DOCUMENT IS THE PROPERTY OF BUILDING DROPS, INC. AND SHALL NOT BE REPRODUCED IN WHOLE OR PART WITHOUT WRITTEN CONSENT OF BUILDING DROPS, INC. ALTERATIONS, ADDITIONS, HIGH-LIGHTING OR OTHER MARKINGS TO THIS DOCUMENT ARE NOT PERMITTED AND INVALID.

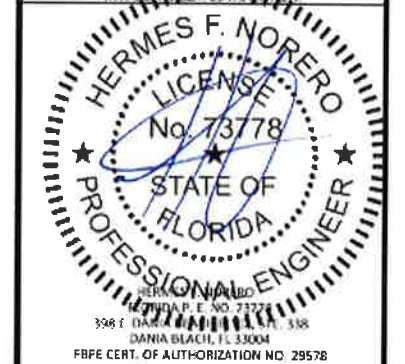

DATE: 02.05.14

DWG. BY: GL/TJM CHK. BY: SS/MSS

SCALE: NTS

DWG. #: A010834A

SHEET: OF 9



RICK SCOTT, GOVERNOR

JONATHAN ZACHEM, SECRETARY



**STATE OF FLORIDA
DEPARTMENT OF BUSINESS AND PROFESSIONAL REGULATION**

CONSTRUCTION INDUSTRY LICENSING BOARD

THE GENERAL CONTRACTOR HEREIN IS CERTIFIED UNDER THE
PROVISIONS OF CHAPTER 489, FLORIDA STATUTES

CAFARO, PETER ANTHONY III

LOWES HOME CENTERS, LLC
1608 CURTIS BRIDGE RD.
WILKESBORO NC 28697

LICENSE NUMBER: CC1508417

EXPIRATION DATE: AUGUST 31, 2020

Always verify licenses online at MyFloridaLicense.com



Do not alter this document in any form.

This is your license. It is unlawful for anyone other than the licensee to use this document.



Risk Management Department

**Re: Lowe's Home Centers, LLC Competency License
Florida General Contractor's License # CGC1508417, Peter Anthony Cafaro, III, Certified
General Contractor.
Florida Contractor's License # CCC1328824, Peter Anthony Cafaro, III, Certified Roofing
Contractor.**

Dear Sir/Madam:

This letter will confirm that Lowe's Home Centers, LLC (a wholly owned subsidiary of Lowe's Companies, Inc. (hereinafter "Lowe's")) intends to satisfy the general liability insurance requirement through a program of self-insurance. Lowe's self insures for each general liability claim in an amount up to and including \$5,000,000 which is the attachment point for Lowe's excess liability policy which is written through Steadfast Insurance Company as evidenced on our certificate of insurance. Lowe's Companies, LLC maintains reserves to support this program of self insurance based on a review (performed at least annually) by a certified casualty actuary.

Lowe's Companies, Inc. is a Fortune 50 company and operates more than 1,750 stores in the US, Canada and Mexico. Lowe's sales in 2014 were in excess of \$53 billion. You may access Lowe's financial information at www.lowes.com.

Please feel free to contact me at (704) 758-3123 or Shonna.M.Splain@Lowes.com if you have any questions.

Very truly yours,

**Shonna Splain
Insurance & Risk Administrator
Risk Management Department**



CERTIFICATE OF LIABILITY INSURANCE

DATE (MM/DD/YYYY)
05/09/2019

THIS CERTIFICATE IS ISSUED AS A MATTER OF INFORMATION ONLY AND CONFERS NO RIGHTS UPON THE CERTIFICATE HOLDER. THIS CERTIFICATE DOES NOT AFFIRMATIVELY OR NEGATIVELY AMEND, EXTEND OR ALTER THE COVERAGE AFFORDED BY THE POLICIES BELOW. THIS CERTIFICATE OF INSURANCE DOES NOT CONSTITUTE A CONTRACT BETWEEN THE ISSUING INSURER(S), AUTHORIZED REPRESENTATIVE OR PRODUCER, AND THE CERTIFICATE HOLDER.

IMPORTANT: If the certificate holder is an ADDITIONAL INSURED, the policy(ies) must have ADDITIONAL INSURED provisions or be endorsed. If SUBROGATION IS WAIVED, subject to the terms and conditions of the policy, certain policies may require an endorsement. A statement on this certificate does not confer rights to the certificate holder in lieu of such endorsement(s).

PRODUCER Marsh USA Inc. 100 North Tryon Street, Suite 3600 Charlotte, NC 28202		CONTACT NAME: PHONE (A/C, No, Ext): _____ FAX (A/C, No): _____ E-MAIL ADDRESS: _____															
CN102776519-Lowes-FLLic-19-20 FL LIC		INSURER(S) AFFORDING COVERAGE															
INSURED Lowe's Companies, Inc and subsidiaries 1000 Lowe's Boulevard Mooresville, NC 28117		<table border="1"> <thead> <tr> <th>INSURER</th> <th>NAIC #</th> </tr> </thead> <tbody> <tr> <td>INSURER A : National Union Fire Ins Co. of Pittsburgh PA</td> <td>19445</td> </tr> <tr> <td>INSURER B : Great American Assurance Co</td> <td>26344</td> </tr> <tr> <td>INSURER C : New Hampshire Ins Company</td> <td>23841</td> </tr> <tr> <td>INSURER D :</td> <td></td> </tr> <tr> <td>INSURER E :</td> <td></td> </tr> <tr> <td>INSURER F :</td> <td></td> </tr> </tbody> </table>		INSURER	NAIC #	INSURER A : National Union Fire Ins Co. of Pittsburgh PA	19445	INSURER B : Great American Assurance Co	26344	INSURER C : New Hampshire Ins Company	23841	INSURER D :		INSURER E :		INSURER F :	
INSURER	NAIC #																
INSURER A : National Union Fire Ins Co. of Pittsburgh PA	19445																
INSURER B : Great American Assurance Co	26344																
INSURER C : New Hampshire Ins Company	23841																
INSURER D :																	
INSURER E :																	
INSURER F :																	

COVERAGES **CERTIFICATE NUMBER:** ATL-004938717-01 **REVISION NUMBER:** 1

THIS IS TO CERTIFY THAT THE POLICIES OF INSURANCE LISTED BELOW HAVE BEEN ISSUED TO THE INSURED NAMED ABOVE FOR THE POLICY PERIOD INDICATED. NOTWITHSTANDING ANY REQUIREMENT, TERM OR CONDITION OF ANY CONTRACT OR OTHER DOCUMENT WITH RESPECT TO WHICH THIS CERTIFICATE MAY BE ISSUED OR MAY PERTAIN, THE INSURANCE AFFORDED BY THE POLICIES DESCRIBED HEREIN IS SUBJECT TO ALL THE TERMS, EXCLUSIONS AND CONDITIONS OF SUCH POLICIES. LIMITS SHOWN MAY HAVE BEEN REDUCED BY PAID CLAIMS

INSR LTR	TYPE OF INSURANCE	ADOL SUBR INSD WVD	POLICY NUMBER	POLICY EFF (MM/DD/YYYY)	POLICY EXP (MM/DD/YYYY)	LIMITS
	COMMERCIAL GENERAL LIABILITY					
	CLAIMS-MADE OCCUR		'Self Insured - See below'			EACH OCCURRENCE \$ DAMAGE TO RENTED PREMISES (Ea occurrence) \$ MED EXP (Any one person) \$ PERSONAL & ADV INJURY \$ GENERAL AGGREGATE \$ PRODUCTS - COMP/OP AGG \$
	GEN'L AGGREGATE LIMIT APPLIES PER POLICY PROJECT LOC OTHER					
A	AUTOMOBILE LIABILITY		CA 4993101 (AOS)	04/01/2019	04/01/2020	COMBINED SINGLE LIMIT (Ea accident) \$ 5,000,000
A	X ANY AUTO		CA 4993103 (MA)	04/01/2019	04/01/2020	BODILY INJURY (Per person) \$
A	OWNED AUTOS ONLY SCHEDULED AUTOS		CA 4993102 (VA)	04/01/2019	04/01/2020	BODILY INJURY (Per accident) \$
	HIRED AUTOS ONLY NON-OWNED AUTOS ONLY					PROPERTY DAMAGE (Per accident) \$
B	X UMBRELLA LIAB X OCCUR		UMB 2276205	04/01/2019	04/01/2020	EACH OCCURRENCE \$ 5,000,000
	EXCESS LIAB CLAIMS MADE					AGGREGATE \$ 5,000,000
	(DED X RETENTION \$					
C	WORKERS COMPENSATION AND EMPLOYERS' LIABILITY		WC 012717162 (AK,AZ,IL,NC,NH,VT)	04/01/2019	04/01/2020	X PER STATUTE OTH ER
C	ANY PROPRIETOR/PARTNER/EXECUTIVE OFFICER/MEMBER EXCLUDED? (Mandatory in NH)	Y/N N	WC 012717160 (ND,WA,WI,WY)	04/01/2019	04/01/2020	E L EACH ACCIDENT \$ 2,000,000
C	If yes, describe under DESCRIPTION OF OPERATIONS below	N/A	WC 012717161 (CO,DC, DE,HI,IL,MI,MN)	04/01/2019	04/01/2020	E L DISEASE - EA EMPLOYEE \$ 2,000,000
A	Excess Workers' Compensation		XWC 5565602 (FL)	04/01/2019	04/01/2020	(WC per statute) \$3,000,000
A	Excess Workers' Compensation		XWC 5565603 (AOS)	04/01/2019	04/01/2020	(WC per statute) \$3,000,000

DESCRIPTION OF OPERATIONS / LOCATIONS / VEHICLES (ACORD 101, Additional Remarks Schedule, may be attached if more space is required)
Commercial General Liability policy is Self-Insured, effective 4/1/2019 to 4/1/2020.
Lowe's Home Centers, Inc. and Lowe's Home Centers, LLC is a named insured under the captioned policies. Florida General Contractor's License # CGC1508417, Peter Anthony Cafaro, III, Certified General Contractor. Florida Contractor's License # CCC1326824, Peter Anthony Cafaro, III, Certified Roofing Contractor.

CERTIFICATE HOLDER

City of Belle Isle
1600 Nela Avenue
Belle Isle, FL 32809

CANCELLATION

SHOULD ANY OF THE ABOVE DESCRIBED POLICIES BE CANCELLED BEFORE THE EXPIRATION DATE THEREOF, NOTICE WILL BE DELIVERED IN ACCORDANCE WITH THE POLICY PROVISIONS.

AUTHORIZED REPRESENTATIVE
of Marsh USA Inc.

Manashi Mukherjee

Manashi Mukherjee

© 1988-2016 ACORD CORPORATION. All rights reserved.



ADDITIONAL REMARKS SCHEDULE

AGENCY Marsh USA, Inc.		NAMED INSURED Lowe's Companies, Inc. and subsidiaries 1000 Lowe's Boulevard Mooreville, NC 28117	
POLICY NUMBER		EFFECTIVE DATE:	
CARRIER	NAIC CODE		

ADDITIONAL REMARKS

**THIS ADDITIONAL REMARKS FORM IS A SCHEDULE TO ACORD FORM,
FORM NUMBER: 25 FORM TITLE: Certificate of Liability Insurance**

TX Employers XS Indemnity Policy Number EE14060054
Safely National Casualty Corporation
Policy Effective Date: 01-Apr-2019
Policy Expiration Date: 01-Apr-2020
Limits: \$4M Each Occurrence / \$20M Aggregate XS \$2M SIR

TX Employers XS Indemnity (Excess) Policy Number --XCB3031
Evanston Insurance Company
Policy Effective Date: 01-Apr-2019
Policy Expiration Date: 01-Apr-2020
Limits: \$15M Each Occurrence / \$20M Aggregate XS \$2M SIR

Workers' Compensation and Excess Workers' Compensation policies include a self-insured retention of \$2,000,000.

General Liability: The insured is self insured for \$10,000,000 each occurrence for the period of 4/1/2019 to 4/1/2020

The Automobile Liability policy evidenced above is subject to additional self-insured retentions across of limits shown for various perils covered.

The Certificate Holder is included as additional insured under the Automobile Liability policy and the General Liability portion of the Umbrella Liability policy for work performed or services provided by the named insured, if required by written contract with the named insured, subject to the terms and conditions of the policy.

This local Business Tax Receipt is in addition to and not in lieu of any other tax required by law or municipal ordinance. Businesses are subject to regulation of zoning, health and other lawful authorities. This receipt is valid from October 1 through September 30 of receipt year. Delinquent penalty is added October 1.

1801 CERTIFIED GENERAL C	2018	EXPIRES 9/30/2019	1801-0590711
1806 CERTIFIED ROOFING CO	\$30.00	2 EMPLOYEES 5000 BUSINESS OFFICE	2 EMPLOYEES :
	\$30.00	2 EMPLOYEES	\$30.00



TOTAL TAX \$90.00
 PREVIOUSLY PAID \$90.00
 TOTAL DUE \$0.00

12200 LAKE UNDERHILL RD
 U - ORLANDO, 32825

CAFARO PETER ANTHONY IN QUALIFIER
 LOWES HOME CENTERS LLC
 CAFARO PETER ANTHONY III
 P O BOX 781983
 ORLANDO FL 32878

PAID: \$90.00 2503-04277893 8/31/2018

This receipt is official when validated by the Tax Collector.

Orange County Code requires this local Business Tax Receipt to be displayed conspicuously at the place of business in public view. It is subject to inspection by all duly authorized officers of the County.

octaxcol.com |    octaxcol