



City of Belle Isle Job Site Card **Roof PERMIT** 2019-08-034

PERMIT MUST BE POSTED ON SITE - A permit expires in 6 months if approved inspections are not recorded /scheduled within that time frame. You are responsible for scheduling and keeping track of all your inspections -

Permit Number: 2019- 08-034

Issue Date: 08/12/2019

Site Address: 5114 Gramont Ave 32812

Parcel #: 17-23-30-4379-01-670

Class: Residential **Subdivision:**

Description of Work: Roof Square Footage: 3159 ASPHALT SHINGLES with **underlayment**

Number of Stories: 1

Issued: JA EDWARDS OF AMERICA, INC.

Business Phone: 407 677-7663

Name: LASCHOB, GERALD RAYMOND

Contractor License: CCC057521

Payment Date & Method: 8 / 12 / 2019 Picked up or sent by _____ Emailed

Visa Master Card Amex Discover Check / Money Order # 0787

**Schedule Inspections via Email at: BDscheduling@universalengineering.com
SCHEDULE INSPECTIONS BY 3:00 PM CUT OFF TIME
Inspection Results Will Be Sent Out the Following Business Day**

"WARNING TO OWNER: YOUR FAILURE TO RECORD A NOTICE OF COMMENCEMENT MAY RESULT IN YOUR PAYING TWICE FOR IMPROVEMENTS TO YOUR PROPERTY. IF YOU INTEND TO OBTAIN FINANCING, CONSULT WITH YOUR LENDER OR AN ATTORNEY BEFORE RECORDING YOUR NOTICE OF COMMENCEMENT."

ROOF	INSPECTOR	DATE	COMMENTS
NEW ROOFS ONLY Code 700 Deck Nailing, Dry-In, Flashing			This inspection only applies for a brand new roof only!
Both new & re-roof Code 710 In - Progress			This inspection consists of all underlayment/black paper coverage and only 25% shingle coverage.
Both new & re-roof Code 720 Final			After the In Progress has been passed, then the entire roof is covered with shingles.

Inspection requests are to be emailed to BDscheduling@UniversalEngineering.com; a confirmation email will be sent back to you upon scheduling. **Next-Day Inspection requests must be made by 3:00 p.m.** Please include the following in your request: Permit #, project address, type of inspection, date of the requested inspection, a contact name & a contact phone number. AM or PM may be requested but cannot be guaranteed. **OSHA Approved Access to the Roof must be made Available to the Inspector.**



City of Belle Isle

Universal Engineering Sciences 3532 Maggie Blvd., Orlando, FL 32811
Tel 407-581-8161 * Fax 407-581-0313 * www.universalengineering.com

RECEIVED
AUG 09 2019

APPLICATION FOR ROOFING PERMIT

WARNING TO OWNER: YOUR FAILURE TO RECORD A NOTICE OF COMMENCEMENT MAY RESULT IN YOUR PAYING TWICE FOR IMPROVEMENTS TO YOUR PROPERTY. A NOTICE OF COMMENCEMENT MUST BE RECORDED AND POSTED ON THE JOB SITE BEFORE THE FIRST INSPECTION. IF YOU INTEND TO OBTAIN FINANCING, CONSULT WITH YOUR LENDER OR AN ATTORNEY BEFORE RECORDING YOUR NOTICE OF COMMENCEMENT.

DATE OF APPLICATION: 08-05-19

ROOF PERMIT NUMBER: 2019-08-034

PLEASE PRINT. The undersigned hereby applies for a permit to make installations as indicated below:

Project Address 5114 Gramont Ave, Belle Isle, FL 32809^X 32812
Property Owner Dennis Cargo Phone 407-797-5780
Property Owner's Mailing Address 5114 Gramont Ave City Belle Isle
State FL Zip Code 32812 Parcel Id Number: 17-23-30-4379-01-670

REQUIRED! To obtain this information, please visit <http://www.ocpafi.org/Searches/ParcelSearch.aspx>

Class of Building: Old New Type of Building: Residential Commercial Other
Type of Work: New Roof ReRoof

REQUIRED! Florida Product Approval Form – NOTE: installation instructions must be posted on-site before your first inspection!!

Please indicate the nature of work by completing the information below:

Roof Square Footage: 3159 Number of Stories: 1 Job Valuation: \$ 18,906.54

Type: Asphalt Shingles Metal Modified Bitumen Other: _____

I hereby certify that the above is true and correct to the best of my knowledge and make Application for Permit as outlined above, and if same is granted I agree to conform to all Florida Building Code Regulations and City Ordinances regulating same and in accordance with plans submitted. The issuance of this permit does not grant permission to violate any applicable Town and/or State of Florida codes and/or ordinances. By signing below, I recognize Republic Services is by legal contract the sole authorized provider of garbage, recycling, yard waste, and commercial garbage and construction debris collection and disposal services with the city limits of the City. Contractors, homeowners and commercial businesses may contact Republic Services at 407-293-8000 to setup accounts for Commercial, Construction Roll Off, or other services needed. Rates are fixed by contract and are available at City Hall or from Republic Services. The City enforces the contract through its code enforcement office. Failure to comply will result in a stop work order.

LICENSE HOLDER SIGNATURE [Signature] LICENSE # CCC057521

LICENSE HOLDER NAME Gerald Laschober COMPANY NAME JA Edwards of America, Inc

Street Address 220 Weber St

City Orlando State FL Zip Code 32803 Phone Number 407-677-7663

Email Address pete@jaeofamerica.com

Zoning Fee \$ 30.-
Building Fee \$ 115.-
Review Fee \$ 0
1% BCAIB Fee \$ 2 min
1.5% DCA Fee \$ 2 min
Total Permit Fee \$ 149.-

Building Official: [Signature] Date 8-12-19
Verified Contractor's Licenses & Insurance are on file [Signature] Date 8-12-19

NOTE: The Building Permit Number is required if the Roof Installation is associated with any construction or alteration where a Building Permit has been issued.

NOCL
1571K
18x5
25
26
115

PAID
2019-08-19

Permit Number: 209-08-034
Folio/Parcel ID #: 17-23.30-4379-01-670
Prepared by: Peter Arcomone

DOCH 20190489426
08/07/2019 02:05:26 PM Page 1 of 1
Rec Fee: \$10.00
Phil Diamond, Comptroller
Orange County, FL
IP - Ret To: JA EDWARDS OF AMERICA INC



Return to: JA Edwards of America, Inc.
220 Weber St.
Orlando Fl. 32803

NOTICE OF COMMENCEMENT

State of Florida, County of Orange
The undersigned hereby gives notice that improvement will be made to certain real property, and in accordance with Chapter 713, Florida Statutes, the following information is provided in this Notice of Commencement.

1. Description of property (legal description of the property, and street address if available)
LAKE CONWAY ESTATES SECTION 34/19 LOT 167; 5114 GRAMONT AVE
2. General description of improvement ORLANDO FL 32812
Re Roof
3. Owner information or Lessee information if the Lessee contracted for the improvement
Name Dennis CARGO
Address 5114 GRAMONT AVE ORLANDO FL 32812
Interest in Property OWNER
Name and address of fee simple titleholder (if different from Owner listed above)
Name _____
Address _____
4. Contractor
Name JA Edwards of America, Inc. Telephone Number 407.677.7663
Address 220 Weber St. Orlando Fl. 32803
5. Surety (if applicable, a copy of the payment bond is attached)
Name _____ Telephone Number _____
Address _____ Amount of Bond \$ _____
6. Lender
Name _____ Telephone Number _____
Address _____
7. Persons within the State of Florida designated by Owner upon whom notices or other documents may be served as provided by §713.13(1)(a)7, Florida Statutes.
Name _____ Telephone Number _____
Address _____
8. In addition to himself or herself, Owner designates the following to receive a copy of the Lienor's Notice as provided in §713.13(1)(b), Florida Statutes.
Name _____ Telephone Number _____
Address _____
9. Expiration date of notice of commencement (the expiration date will be 1 year from the date of recording unless a different date is specified) _____

WARNING TO OWNER: ANY PAYMENTS MADE BY THE OWNER AFTER THE EXPIRATION OF THE NOTICE OF COMMENCEMENT ARE CONSIDERED IMPROPER PAYMENTS UNDER CHAPTER 713, PART I, SECTION 713.13, FLORIDA STATUTES, AND CAN RESULT IN YOUR PAYING TWICE FOR IMPROVEMENTS TO YOUR PROPERTY. A NOTICE OF COMMENCEMENT MUST BE RECORDED AND POSTED ON THE JOB SITE BEFORE THE FIRST INSPECTION. IF YOU INTEND TO OBTAIN FINANCING, CONSULT WITH YOUR LENDER OR AN ATTORNEY BEFORE COMMENCING WORK OR RECORDING YOUR NOTICE OF COMMENCEMENT.

Signature of Owner or lessee, or Owner's or Lessee's Authorized Officer/Director/Partner/Manager: Dennis Cargo Signatory's Title/Office: _____

The foregoing instrument was acknowledged before me this 5 day of August by Dennis Cargo name of person

as OWNER for Dennis Cargo Name of party on behalf of whom instrument was executed

Signature of Notary Public - State of Florida: _____ Prnt, type, or stamp commissioned name of Notary Public

Personally Known _____ OR Produced ID
Type of ID Produced FLDL

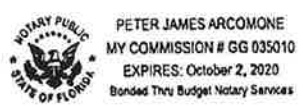

Form content revised: 01/23/14

State of FLORIDA, County of ORANGE
I hereby certify that this is a true copy of the document as recorded in the Office of the
PHIL DIAMOND, COUNTY COMPTROLLER
BY: [Signature], D.C.
DATED: AUG 07 2019





CITY OF BELLE ISLE, FLORIDA
Universal Engineering Sciences 3532 Maggie Blvd., Orlando, FL 32811
Tel 407-581-8161 * Fax 407-581-0313 * www.universalengineering.com



POWER OF ATTORNEY

Date: 08-05-19

Permit #: 2019-08-034

I hereby name and appoint Peter Arcomone of
(print name)
JA Edwards of America, Inc. to be my lawful attorney-in-fact to act for
(company name)

me and apply to the City of Belle Isle Building Department for a Roofing permit
(type of permit)
for work to be performed at the following location:

5114 Gramont Ave, Belle Isle, FL 32809 32812 and
(street address)

to sign my name and do all things necessary to this appointment.

Certified Contractor's Printed Name: Gerald Laschober

License Number: CCC057521

Certified Contractor's Signature: 

.....
The foregoing instrument was acknowledged before me this 5 days of Aug of 20 19
by Gerald Laschober who is personally known to me or who produced
as identification and who did not take an oath

State of Florida
County of Orange

 RENEE CHRISTINE COLLINS
Notary Public, Orange County, Florida



RENEE C. COLLINS
Commission # GG 172994
Expires January 7, 2022
Bonded Thru Budget Notary Services

(seal)



City of Belle Isle

Universal Engineering Sciences 3532 Maggie Blvd., Orlando, FL 32811
 Tel 407-581-8161 * Fax 407-581-0313 * www.universalengineering.com

Product Approval Form

DATE: 08-05-19

PERMIT # 2019-08-034

PROJECT ADDRESS 5114 Gramont Ave, Belle Isle, FL 32809 X 32812

As required by Florida Statute 553.842 and Florida Administrative Code 9B-72m, please provide the information and approval numbers of the building components listed below if they will be utilized on the building or structure. FL Approved products are listed online at www.floridabuilding.org or can be obtained from the local product supplier. The following information must be turned in with permit application and available onsite for inspections:

• **NOTE: The Installation instructions must be posted on-site before your first inspection!!**

Product Type	Manufacturer	Model/Series	FL Product Approval #	Product Type	Manufacturer	Model/Series	FL Product Approval #
EXTERIOR DOORS				WALL PANELS			
Swinging				Sliding			
Sliding				Soffits			
Sectional/Rollup				Storefront			
Other				Glass Block			
				Other			
WINDOWS				ROOFING PRODUCTS			
Single/Dbf Hung				Asphalt Shingles	GAF	Timberline	FL10124-R22
Horizontal Slider				Non Struct Metal			
Casement				Roofing Tiles			
Fixed				Single Ply Roof			
Mullion				Underlayment	Interwrap	RhinoRoof	FL15216-R4
Skylights				Other			
Other							
STRUCTURAL COMPONENTS				OTHER			
Wood Connectors							
Wood Anchors							
Truss Plates							
Insulation Forms							
Lintels							
Other							

It is the applicant's responsibility to verify that specific products have been installed in accordance with their limitations and with the minimum required design pressures for the structure. Specific compliance will be verified during field inspections.

Applicant Signature 

Date 08-05-19



[BCIS Home](#) | [Log In](#) | [User Registration](#) | [Hot Topics](#) | [Submit Surcharge](#) | [Stats & Facts](#) | [Publications](#) | [Contact Us](#) | [BCIS Site Map](#) | [Links](#) | [Search](#)



Product Approval
USER: Public User

[Product Approval Menu](#) > [Product or Application Search](#) > [Application List](#) > **Application Detail**

OFFICE OF THE SECRETARY

FL #	FL10124-R22												
Application Type	Revision												
Code Version	2017												
Application Status	Approved												
Comments													
Archived													
Product Manufacturer	GAF												
Address/Phone/Email	1 Campus Drive Parisppany, NJ 07054 (800) 766-3411 mstieh@gaf.com												
Authorized Signature	Robert Nieminen lreith@nemoetc.com												
Technical Representative	William Broussard												
Address/Phone/Email	1 Campus Drive Parsippany, NJ 07054 (800) 766-3411 TechnicalQuestionsGAF@gaf.com												
Quality Assurance Representative													
Address/Phone/Email													
Category	Roofing												
Subcategory	Asphalt Shingles												
Compliance Method	Evaluation Report from a Florida Registered Architect or a Licensed Florida Professional Engineer Evaluation Report - Hardcopy Received												
Florida Engineer or Architect Name who developed the Evaluation Report	Robert Nieminen												
Florida License	PE-59166												
Quality Assurance Entity	UL LLC												
Quality Assurance Contract Expiration Date	10/18/2021												
Validated By	John W. Knezevich, PE ✓ Validation Checklist - Hardcopy Received												
Certificate of Independence	FL10124 R22 COI 2019 01 COI NIEMINEN.pdf												
Referenced Standard and Year (of Standard)	<table border="0"> <thead> <tr> <th>Standard</th> <th>Year</th> </tr> </thead> <tbody> <tr> <td>ASTM D1970</td> <td>2015</td> </tr> <tr> <td>ASTM D3161</td> <td>2016</td> </tr> <tr> <td>ASTM D3462</td> <td>2010</td> </tr> <tr> <td>ASTM D7158</td> <td>2011</td> </tr> <tr> <td>TAS 107</td> <td>1995</td> </tr> </tbody> </table>	Standard	Year	ASTM D1970	2015	ASTM D3161	2016	ASTM D3462	2010	ASTM D7158	2011	TAS 107	1995
Standard	Year												
ASTM D1970	2015												
ASTM D3161	2016												
ASTM D3462	2010												
ASTM D7158	2011												
TAS 107	1995												
Equivalence of Product Standards Certified By													

Sections from the Code

Product Approval Method Method 1 Option D

Date Submitted 04/17/2019

Date Validated 04/21/2019

Date Pending FBC Approval 04/25/2019

Date Approved 06/18/2019

Summary of Products

FL #	Model, Number or Name	Description
10124.1	GAF Asphalt Roof Shingles	Fiberglass reinforced 3-tab, laminated, 5-tab and hip/ridge asphalt shingles
Limits of Use Approved for use in HVHZ: No Approved for use outside HVHZ: Yes Impact Resistant: N/A Design Pressure: N/A Other: Refer to ER, Section 5.		Installation Instructions FL10124_R22_II_2019_04_FINAL_ER_GAF ASPHALT SHINGLES_FL10124-R22.pdf Verified By: Robert Nieminen PE-59166 Created by Independent Third Party: Yes Evaluation Reports FL10124_R22_AE_2019_04_FINAL_ER_GAF ASPHALT SHINGLES_FL10124-R22.pdf Created by Independent Third Party: Yes

[Back](#) [Next](#)

Contact Us :: [2601 Blair Stone Road, Tallahassee FL 32399](#) Phone: 850-487-1824

The State of Florida is an AA/EEO employer. [Copyright 2007-2013 State of Florida.](#) :: [Privacy Statement](#) :: [Accessibility Statement](#) :: [Refund Statement](#)

Under Florida law, email addresses are public records. If you do not want your e-mail address released in response to a public-records request, do not send electronic mail to this entity. Instead, contact the office by phone or by traditional mail. If you have any questions, please contact 850.487.1395. *Pursuant to Section 455.275(1), Florida Statutes, effective October 1, 2012, licensees licensed under Chapter 455, F.S. must provide the Department with an email address if they have one. The emails provided may be used for official communication with the licensee. However email addresses are public record. If you do not wish to supply a personal address, please provide the Department with an email address which can be made available to the public. To determine if you are a licensee under Chapter 455, F.S., please click [here](#).



Credit Card
Safe





NEMO|etc.

Certificate of Authorization #32455
353 Christian Street, Unit #13
Oxford, CT 06478
(203) 262-9245

ENGINEER

EVALUATE

TEST

CONSULT

CERTIFY

EVALUATION REPORT

GAF

1 Campus Drive
Parsippany, NJ 07054
(800) 766-3411

Evaluation Report 01506.01.08-R24

FL10124-R22

Date of Issuance: 01/03/2008

Revision 24: 04/12/2019

SCOPE:

This Evaluation Report is issued under **Rule 61G20-3** and the applicable rules and regulations governing the use of construction materials in the State of Florida. The documentation submitted has been reviewed by Robert Nieminen, P.E. for use of the product under the Florida Building Code and Florida Building Code, Residential Volume. The products described herein have been evaluated for compliance with the **6th Edition (2017) Florida Building Code** sections noted herein.

DESCRIPTION: GAF Asphalt Roof Shingles

LABELING: Labeling shall be in accordance with the requirements of the Accredited Quality Assurance Agency noted herein and **FBC 1507.2.7.1 / R905.2.6.1**

CONTINUED COMPLIANCE: This Evaluation Report is valid until the named product(s) changes, the referenced Quality Assurance documentation changes, or provisions of the Code that relate to the product change. Acceptance of this Evaluation Report by the named client constitutes agreement to notify Robert Nieminen, P.E. of any changes to the product(s), the Quality Assurance or the production facility location(s). NEMO|etc. requires a complete review of this Evaluation Report relative to updated Code requirements with each Code Cycle.

ADVERTISEMENT: The Evaluation Report number preceded by the words "NEMO|etc. Evaluated" may be displayed in advertising literature. If any portion of the Evaluation Report is displayed, then it shall be done in its entirety.

INSPECTION: Upon request, a copy of this entire Evaluation Report shall be provided to the user by the manufacturer or its distributors and shall be available for inspection at the job site at the request of the Building Official.

This Evaluation Report consists of pages 1 through 6.

Prepared by:



Robert J.M. Nieminen, P.E.

Florida Registration No. 59166, Florida DCA ANE1983

The facsimile seal appearing was authorized by Robert Nieminen, P.E. on 04/12/2019. This does not serve as an electronically signed document.

CERTIFICATION OF INDEPENDENCE:

1. NEMO|etc. does not have, nor does it intend to acquire, or will it acquire, a financial interest in any company manufacturing or distributing products it evaluates.
2. NEMO|etc. is not owned, operated or controlled by any company manufacturing or distributing products it evaluates.
3. Robert Nieminen, P.E. does not have nor will acquire, a financial interest in any company manufacturing or distributing products for which the evaluation reports are being issued.
4. Robert Nieminen, P.E. does not have, nor will acquire, a financial interest in any other entity involved in the approval process of the product.
5. This is a building code evaluation. Neither NEMO|etc. nor Robert Nieminen, P.E. are, in any way, the Designer of Record for any project on which this Evaluation Report, or previous versions thereof, is/was used for permitting or design guidance unless retained specifically for that purpose.



ROOFING SYSTEMS EVALUATION:

1. SCOPE:

Product Category: Roofing
Sub-Category: Asphalt Shingles

Compliance Statement: GAF Asphalt Roof Shingles, as produced by GAF, have demonstrated compliance with the following sections of the 6th Edition (2017) Florida Building Code and Florida Building Code, Residential Volume through testing in accordance with the following Standards. Compliance is subject to the Installation Requirements and Limitations / Conditions of Use set forth herein.

2. STANDARDS:

Table with 4 columns: Section, Property, Standard, Year. Lists standards such as 1507.2.4, R905.2.3, 1507.2.5, R905.2.4, etc.

3. REFERENCES:

Table with 4 columns: Entity, Examination, Reference, Date. Lists various testing entities like PRI (TST 5878), UL (TST 1740) and their corresponding standards and dates.



<u>Entity</u>	<u>Examination</u>	<u>Reference</u>	<u>Date</u>
UL (TST 1740)	ASTM D3161	06CA31611	04/04/2007
UL (TST 1740)	ASTM D3161	06CA61148	04/09/2007
UL (TST 1740)	ASTM D3161, D3462	07CA31742	11/08/2007
UL (TST 1740)	ASTM D3161, D7158, D3462	08CA06100	03/13/2008
UL, LLC. (TST 9628)	ASTM D3161	4788698165	03/24/2008
UL (TST 1740)	ASTM D3161, D3462	07CA55908	04/01/2008
UL (TST 1740)	ASTM D3161, D3462	09CA10592	03/26/2009
UL (TST 1740)	ASTM D3161, D3462	09CA06856	05/15/2009
UL (TST 1740)	ASTM D3161, D7158, D3462	09NK06647	08/01/2009
UL (TST 1740)	ASTM D3161, D7158, D3462	09CA27281	08/27/2009
UL (TST 1740)	ASTM D3161, D7158, D3462	10CA35554	03/05/2010
UL (TST 1740)	ASTM D3161, D7158, D3462	10CA13686	05/15/2010
UL (TST 1740)	ASTM D3462	10CA07264	05/27/2010
UL (TST 1740)	ASTM D3462	10CA11953	10/29/2010
UL (TST 1740)	ASTM D3161, D7158, D3462	10NK11951	10/30/2010
UL (TST 1740)	ASTM D3161, D7158, D3462	10NK12070	11/04/2010
UL (TST 1740)	ASTM D3161, D7158, D3462	08CA06100	01/30/2010
UL (TST 1740)	ASTM D3161, D7158, D3462	10CA53934	03/31/2011
UL (TST 1740)	ASTM D3161, D7158, D3462	11CA48924	10/22/2011
UL (TST 1740)	ASTM D3161, D7158, D3462	11CA47919	12/03/2011
UL (TST 1740)	ASTM D3161, D7158, D3462	11CA48408	12/08/2011
UL (TST 1740)	ASTM D3161, D7158, D3462	11CA48725	12/09/2011
UL, LLC. (TST 9628)	ASTM D3462	12CA34891	10/12/2012
UL, LLC. (TST 9628)	ASTM D3161, D7158, D3462	12CA58151	02/15/2013
UL, LLC. (TST 9628)	ASTM D3161	12CA38083	02/26/2013
UL, LLC. (TST 9628)	ASTM D3161	13CA32332	06/18/2013
UL, LLC. (TST 9628)	ASTM D3161	13CA37934	08/02/2013
UL, LLC. (TST 9628)	ASTM D3161, D7158, D3462	4786875675	07/17/2015
UL, LLC. (TST 9628)	ASTM D3161, D7158, D3462	4787434542	05/17/2016
UL, LLC. (TST 9628)	ASTM D3161, D7158, D3462	4788717529	09/09/2016
UL, LLC. (TST 9628)	ASTM D3161	4788669132	12/13/2018
UL, LLC. (TST 9628)	ASTM D3161	4788891098	02/14/2019
UL, LLC. (QUA 9625)	Quality Control	Service Confirmation	10/18/2018

4. PRODUCT DESCRIPTION:

4.1 ACCESSORY STARTER STRIPS:

- 4.1.1 Pro-Start® Eave/Rake Starter Strip Shingles and WeatherBlocker™ Premium Eave/Rake Starter Strip Shingles are starter strips for asphalt roof shingles. Meets ASTM D3462.
- 4.1.2 QuickStart® Peel & Stick Starter Roll is a mineral-surfaced, fiberglass-reinforced, self-adhering SBS modified bitumen starter strip, nominal 9-inch x 33 ft roll, for use with asphalt shingles with exposure of 6-inch or less. Meets ASTM D1970.
- 4.1.3 StarterMatch™ Starter Strip Shingles are color-coordinated starter strips for use with Grand Canyon® and Grand Sequoia® series asphalt shingles. StarterMatch™ are installed as the second starter for Grand Canyon® and Grand Sequoia® series installations. Meets ASTM D3462.

4.2 ASPHALT SHINGLES:

- 4.2.1 Marquis WeatherMax®, Royal Sovereign® and Sentinel® are a fiberglass reinforced 3-tab asphalt roof shingles.
- 4.2.2 Camelot®, Camelot® II, Fortitude™, Glenwood™, Grand Canyon®, Grand Sequoia®, Grand Sequoia® IR, Grand Sequoia® ArmorShield™, Sienna®, Timberline® American Harvest®, Timberline® ArmorShield™ II, Timberline® Natural Shadow®, Timberline HD®, Timberline® HDZ™, Timberline® Cool Series®, Timberline Ultra HD® and Woodland® are fiberglass reinforced, laminated asphalt roof shingles.
- 4.2.3 Slateline® is a fiberglass reinforced 5-tab asphalt roof shingle.

4.3 HIP & RIDGE SHINGLES:

- 4.3.1 Seal-A-Ridge® Ridge Cap Shingles, Seal-A-Ridge® ArmorShield™ Ridge Cap Shingles and Timbertex® Premium Ridge Cap Shingles are fiberglass reinforced, hip and ridge asphalt roof shingles.

5. LIMITATIONS:

- 5.1 This is a building code evaluation. Neither NEMO ETC, LLC nor Robert Nieminen, P.E. are, in any way, the Designer of Record for any project on which this Evaluation Report, or previous versions thereof, is/was used for permitting or design guidance unless retained specifically for that purpose.
- 5.2 This Evaluation Report is not for use in FBC HVHZ jurisdictions.
- 5.3 Fire Classification is not part of this Evaluation Report; refer to current Approved Roofing Materials Directory for fire ratings of this product.

5.4 Wind Classification:

- 5.4.1 The GAF asphalt shingles noted in Section 4.2 are Classified in accordance with FBC Tables 1507.2.7.1 and R905.2.6.1 to ASTM D3161, Class F and/or ASTM D7158, Class H, indicating the shingles are acceptable for use in all wind zones up to $V_{asd} = 150$ mph ($V_{ult} = 194$ mph). Refer to Section 6 for installation requirements to meet this wind rating.

Note: Classification by ASTM D7158 applies only to exposure category B or C, as defined in FBC 1609.4.3, and a mean roof height of 60 feet or less. Calculations by a qualified design professional are required for conditions outside these limitations. Contact the shingle manufacturer for data specific to each shingle.

- 5.4.2 The GAF hip & ridge shingles noted in Section 4.3 are Classified in accordance with FBC Tables 1507.2.7.1 and R905.2.6.1 to ASTM D3161, Class F, indicating the shingles are acceptable for use in all wind zones up to $V_{asd} = 150$ mph ($V_{ult} = 194$ mph). Refer to Section 6 for installation requirements to meet this wind rating.
- 5.5 All products in the roof assembly shall have quality assurance audit in accordance with F.A.C. Rule 61G20-3.

6. INSTALLATION:

6.1 GENERAL:

- 6.1.1 Roof deck, slope, underlayment and fasteners shall comply with FBC 1507.2 / R905.2 and the shingle manufacturer's minimum requirements.
- 6.1.2 Underlayment shall be acceptable to GAF and shall hold current Florida Statewide Product Approval, or be Locally Approved per Rule 61G20-3, per FBC Sections 1507.2.3, 1507.2.4 or R905.2.3.
- 6.1.3 Fasteners shall be in accordance with manufacturer's published requirements, but not less than FBC 1507.2.6 or R905.2.5. Staples are not permitted.
- 6.1.4 GAF asphalt shingles are acceptable for use in reroof (tear-off) or recover applications, subject to the limitations set forth in FBC Section 1511 or R908 and CertainTeed published installation instructions.

6.2 STARTER SHINGLES OR STARTER STRIP:

- 6.2.1 Installation of Pro-Start Eave/Rake Starter Strip Shingles, WeatherBlocker Premium Eave/Rake Starter Strip Shingles and QuickStart Peel & Stick Starter Roll shall comply with the GAF current published instructions.

6.3 ASPHALT SHINGLES:

- 6.3.1 Installation of asphalt shingles shall comply with the GAF current published instructions, using minimum four (4) nails per shingle in accordance with FBC 1507.2.7 or R905.2.6, with the following exceptions:
 - Camelot, Camelot II, Grand Canyon, Grand Sequoia, Grand Sequoia IR, Grand Sequoia ArmorShield, and Woodland require minimum five (5) nails per shingle.
 - Slateline requires minimum six (6) nails per shingle.
- 6.3.2 Fasteners shall be in accordance with manufacturer’s published requirements, but not less than FBC 1507.2.6 or R905.2.5. Staples are not permitted.
- 6.3.2.1 Fastening for Timberline® HDZ™; slopes 2:12 up to 21:12

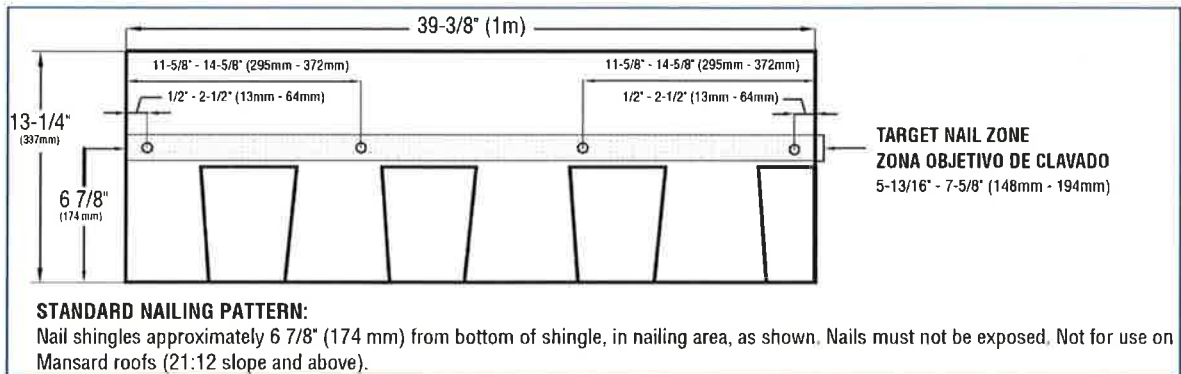

- 6.3.3 Where the roof slope exceeds 21 units vertical in 12 units horizontal, special methods of fastening are required. Contact the GAF for details.
- 6.3.3.1 Fastening for Timberline® HDZ™; slopes greater than 21:12

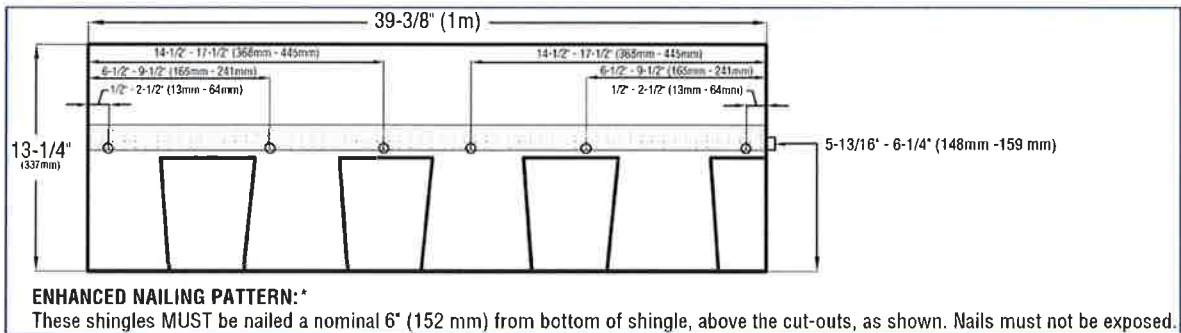



6.4 HIP & RIDGE SHINGLES:

6.4.1 Installation of Seal-A-Ridge Ridge Cap Shingles and Seal-A-Ridge ArmorShield Ridge Cap Shingles shall comply with the GAF current published instructions with a minimum two (2) nails, minimum 3/8-inch head diameter, per shingle and nominal 0.25-inch diameter beads of Henkel "Loctite PL S30 Roof & Flashing Sealant".

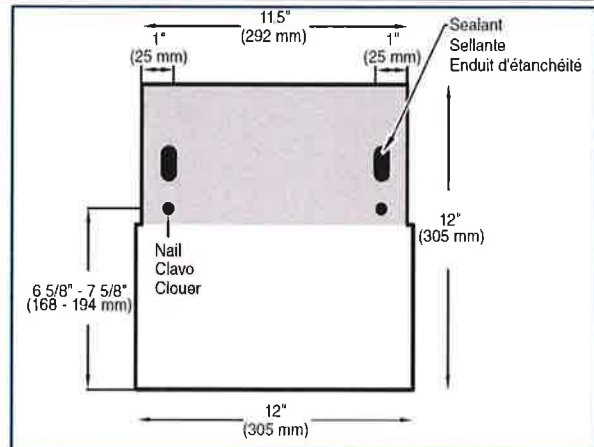

6.4.2 Installation of Timbertex Premium Ridge Cap Shingles shall comply with GAF current published instructions with a minimum two (2) nails, minimum 3/8-inch head diameter, per shingle and beads of Sonneborn "NP1 Gun Grade Polyurethane Sealant" or Henkel "PL Roofing and Flashing Sealant".

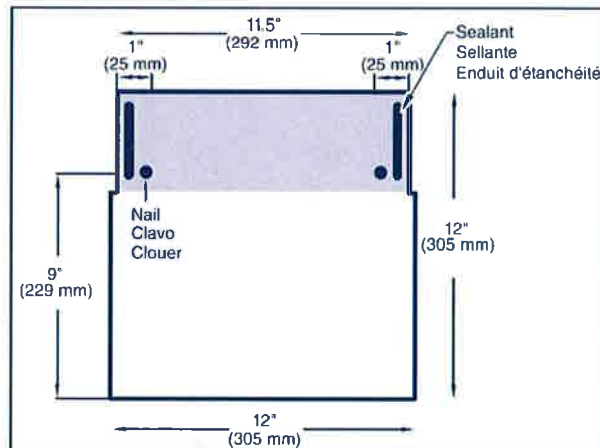

6.4.3 Fasteners shall be in accordance with GAF published requirements, but not less than FBC 1507.2.6 or R905.2.5. Staples are not permitted.

7. LABELING:

- 7.1 Labeling shall be in accordance with the requirements the Accredited Quality Assurance Agency noted herein.
- 7.2 Asphalt shingle wrappers shall indicate compliance with one of the required classifications detailed in **FBC Table 1507.2.7.1 / R905.2.6.1**.

8. BUILDING PERMIT REQUIREMENTS:

As required by the Building Official or Authority Having Jurisdiction in order to properly evaluate the installation of this product.

9. MANUFACTURING PLANTS:

Contact the named QA entity for information on which plants produce products covered by Florida Rule 61G20-3 QA requirements.

10. QUALITY ASSURANCE ENTITY:

UL LLC – QUA9625; (414) 248-6409; karen.buchmann@ul.com

- END OF EVALUATION REPORT -



[DBPR HOME](#) | [ABOUT DBPR](#) | [DBPR DIVISIONS](#) | [CONTACT DBPR](#)

[BCIS Home](#) | [Log In](#) | [User Registration](#) | [Hot Topics](#) | [Submit Surcharge](#) | [Stats & Facts](#) | [Publications](#) | [Contact Us](#) | [BCIS Site Map](#) | [Links](#) | [Search](#)



Product Approval
USER: Public User

[Product Approval Menu](#) > [Product or Application Search](#) > [Application List](#) > **Application Detail**

OFFICE OF THE SECRETARY

FL #	FL15216-R4								
Application Type	Revision								
Code Version	2017								
Application Status	Approved								
Comments									
Archived									
Product Manufacturer	Owens Corning Roofing and Asphalt, LLC								
Address/Phone/Email	One Owens Corning Parkway Toledo, OH 43645 (740) 321-6345 Greg.Keeler@owenscorning.com								
Authorized Signature	Keeler Greg Greg.Keeler@owenscorning.com								
Technical Representative	Greg Keeler								
Address/Phone/Email	2790 Columbus Road Granville, OH 43023 (740) 321-6345 greg.keeler@owenscorning.com								
Quality Assurance Representative									
Address/Phone/Email									
Category	Roofing								
Subcategory	Underlayments								
Compliance Method	Evaluation Report from a Florida Registered Architect or a Licensed Florida Professional Engineer Evaluation Report - Hardcopy Received								
Florida Engineer or Architect Name who developed the Evaluation Report	Robert Nieminen								
Florida License	PE-59166								
Quality Assurance Entity	Intertek Testing Services NA, Inc. - QA Entity								
Quality Assurance Contract Expiration Date	12/31/2020								
Validated By	John W. Knezevich, PE ✓ Validation Checklist - Hardcopy Received								
Certificate of Independence	FL15216_R4_COI_2018_01_COI_NIEMINEN.pdf								
Referenced Standard and Year (of Standard)	<table border="0"> <thead> <tr> <th>Standard</th> <th>Year</th> </tr> </thead> <tbody> <tr> <td>ASTM D1970 (tear)</td> <td>2015</td> </tr> <tr> <td>ASTM D226 (physicals)</td> <td>2009</td> </tr> <tr> <td>TAS 117(B)</td> <td>1995</td> </tr> </tbody> </table>	Standard	Year	ASTM D1970 (tear)	2015	ASTM D226 (physicals)	2009	TAS 117(B)	1995
Standard	Year								
ASTM D1970 (tear)	2015								
ASTM D226 (physicals)	2009								
TAS 117(B)	1995								
Equivalence of Product Standards Certified By									
Sections from the Code									

Product Approval Method	Method 1 Option D
Date Submitted	04/20/2018
Date Validated	04/20/2018
Date Pending FBC Approval	04/22/2018
Date Approved	06/12/2018

Summary of Products

FL #	Model, Number or Name	Description
15216.1	RhinoRoof Underlayments	Synthetic roof underlayments
Limits of Use Approved for use in HVHZ: No Approved for use outside HVHZ: Yes Impact Resistant: N/A Design Pressure: N/A Other: See ER Section 5 for Limits of Use.		Installation Instructions FL15216 R4 II 2018 04 FINAL ER OWENS CORNING RHINOROOF FL15216-R4.pdf Verified By: Robert Nieminen PE-59166 Created by Independent Third Party: Yes Evaluation Reports FL15216 R4 AE 2018 04 FINAL ER OWENS CORNING RHINOROOF FL15216-R4.pdf Created by Independent Third Party: Yes

Contact Us :: 2601 Blair Stone Road, Tallahassee FL 32399 Phone: 850-487-1824

The State of Florida is an AA/EEO employer. [Copyright 2007-2013 State of Florida](#). :: [Privacy Statement](#) :: [Accessibility Statement](#) :: [Refund Statement](#)

Under Florida law, email addresses are public records. If you do not want your e-mail address released in response to a public-records request, do not send electronic mail to this entity. Instead, contact the office by phone or by traditional mail. If you have any questions, please contact 850.487.1395. *Pursuant to Section 455.275(1), Florida Statutes, effective October 1, 2012, licensees licensed under Chapter 455, F.S. must provide the Department with an email address if they have one. The emails provided may be used for official communication with the licensee. However email addresses are public record. If you do not wish to supply a personal address, please provide the Department with an email address which can be made available to the public. To determine if you are a licensee under Chapter 455, F.S., please click [here](#).

Product Approval Accepts:



Credit Card
Safe





NEMO|etc.

Certificate of Authorization #32455
353 Christian Street, Unit #13
Oxford, CT 06478
(203) 262-9245

ENGINEER

EVALUATE

TEST

CONSULT

CERTIFY

EVALUATION REPORT

Owens Corning Roofing and Asphalt, LLC

One Owens Corning Parkway
Toledo, OH 43659
(740) 321-6345

Evaluation Report I40510.02.12-R4

FL15216-R4

Date of Issuance: 02/17/2012

Revision 4: 04/19/2018

SCOPE:

This Evaluation Report is issued under **Rule 61G20-3** and the applicable rules and regulations governing the use of construction materials in the State of Florida. The documentation submitted has been reviewed by Robert Nieminen, P.E. for use of the product under the Florida Building Code and Florida Building Code, Residential Volume. The products described herein have been evaluated for compliance with the **6th Edition (2017) Florida Building Code** sections noted herein.

DESCRIPTION: RhinoRoof Underlayments

LABELING: Labeling shall be in accordance with the requirements of the Accredited Quality Assurance Agency noted herein.

CONTINUED COMPLIANCE: This Evaluation Report is valid until such time as the named product(s) changes, the referenced Quality Assurance documentation changes, or provisions of the Code that relate to the product change. Acceptance of this Evaluation Report by the named client constitutes agreement to notify Robert Nieminen, P.E. of any changes to the product(s), the Quality Assurance or the production facility location(s). NEMO|etc. requires a complete review of this Evaluation Report relative to updated Code requirements with each Code Cycle.

ADVERTISEMENT: The Evaluation Report number preceded by the words "NEMO|etc. Evaluated" may be displayed in advertising literature. If any portion of the Evaluation Report is displayed, then it shall be done in its entirety.

INSPECTION: Upon request, a copy of this entire Evaluation Report shall be provided to the user by the manufacturer or its distributors and shall be available for inspection at the job site at the request of the Building Official.

This Evaluation Report consists of pages 1 through 3.

Prepared by:

Robert J.M. Nieminen, P.E.

Florida Registration No. 59166, Florida DCA ANE1983



The facsimile seal appearing was authorized by Robert Nieminen, P.E. on 04/19/2018. This does not serve as an electronically signed document.

CERTIFICATION OF INDEPENDENCE:

1. NEMO ETC, LLC does not have, nor does it intend to acquire or will it acquire, a financial interest in any company manufacturing or distributing products it evaluates.
2. NEMO ETC, LLC is not owned, operated or controlled by any company manufacturing or distributing products it evaluates.
3. Robert Nieminen, P.E. does not have nor will acquire, a financial interest in any company manufacturing or distributing products for which the evaluation reports are being issued.
4. Robert Nieminen, P.E. does not have, nor will acquire, a financial interest in any other entity involved in the approval process of the product.
5. This is a building code evaluation. Neither NEMO|etc. nor Robert Nieminen, P.E. are, in any way, the Designer of Record for any project on which this Evaluation Report, or previous versions thereof, is/was used for permitting or design guidance unless retained specifically for that purpose.

ROOFING COMPONENT EVALUATION:
1. SCOPE:

Product Category: Roofing
Sub-Category: Underlayment

Compliance Statement: RhinoRoof Underlayments, as produced by Owens Corning Roofing and Asphalt, LLC, has demonstrated compliance with the following sections of the 6th Edition (2017) Florida Building Code through testing in accordance with applicable sections of the following Standards. Compliance is subject to the Installation Requirements and Limitations / Conditions of Use set forth herein.

2. STANDARDS:

<u>Section</u>	<u>Properties</u>	<u>Standard</u>	<u>Year</u>
1507.1.1, R905.1.1 Exception	Unrolling, Breaking Strength, Pliability	ASTM D226	2009
1507.1.1, R905.1.1 Exception	Tear Strength	ASTM D1970	2015
TAS 110	Pull-through resistance	TAS 117(B)	1995

3. REFERENCES:

<u>Entity</u>	<u>Examination</u>	<u>Reference</u>	<u>Date</u>
ITS (TST1509)	Physical Properties	100539395COQ-006	10/27/2011
ITS (TST1509)	Physical Properties	100539395COQ-002	10/27/2011
ITS (TST1509)	Physical Properties	100539395COQ-006	03/14/2014
PRI (TST5878)	ASTM D1970; Tear strength	OCF-330-02-02	10/03/2017
PRI (TST5878)	TAS 117(B); Pull-through	OCF-422-02-01	04/03/2018
ITS (QUA1673)	Quality Control	Service Confirmation	09/30/2017

4. PRODUCT DESCRIPTION:

4.1 **RhinoRoof U20** is a multilayered polymer woven coated synthetic roof underlayment available in 42-inch wide rolls, and can be produced in various other sizes; meets FBC 1507.1.1 & R905.1.1 (Exception).

5. LIMITATIONS:

- 5.1 This is a building code evaluation. Neither NEMO ETC, LLC nor Robert Nieminen, P.E. are, in any way, the Designer of Record for any project on which this Evaluation Report, or previous versions thereof, is/was used for permitting or design guidance unless retained specifically for that purpose.
- 5.2 This Evaluation Report is not for use in FBC HVHZ jurisdictions.
- 5.3 Fire Classification is not part of this Evaluation Report; refer to current Approved Roofing Materials Directory or test report from accredited testing agency for fire ratings of this product.
- 5.4 **RhinoRoof Underlayments** may be used with any prepared roof cover where the product is specifically referenced within FBC approval documents. If not listed, a request may be made to the Authority Having Jurisdiction for approval based on this evaluation combined with supporting data for the prepared roof covering.

5.5 Allowable Roof Covers:

TABLE 1: ROOF COVER OPTIONS						
Underlayment	Asphalt Shingles	Nail-On Tile	Foam-On Tile	Metal	Wood Shakes & Shingles	Slate or Simulated Slate
RhinoRoof U20	Yes	No	No	Yes	Yes	No

5.6 Exposure Limitations:

RhinoRoof U20 shall not be left exposed for longer than **30-days** after installation.

6. INSTALLATION:

- 6.1 **RhinoRoof Underlayments** shall be installed in accordance with **Owens Corning Roofing and Asphalt, LLC** published installation instructions subject to the Limitations set forth in Section 5 herein and the specifics noted below.
- 6.2 Re-fasten any loose decking panels, and check for protruding nail heads. Sweep the substrate thoroughly to remove any dust and debris prior to application.

6.3 **RhinoRoof U20:**

- 6.3.1 Shall be installed in compliance with the requirements for **ASTM D226, Type I or II** underlayment in **FBC Table 1507.1.1 or R905.1.1** for the type of prepared roof covering to be installed, taking into account the wider sheet-width.

6.3.2 Fasteners:

For exposure \leq 24 hours, corrosion resistant fasteners may be 1-inch roofing nails with a 3/8-inch diameter head, minimum 1-inch diameter plastic or metal cap nails or FBC HVHZ nails & 1-5/8" diameter tin caps (with the rough edge facing up). The use of staples is prohibited.

For exposure > 24 hours up to maximum 30 days, corrosion resistant fasteners shall be minimum 1-inch diameter plastic or metal cap nails or FBC HVHZ nails & 1-5/8" diameter tin caps (with the rough edge facing up). The use of staples is prohibited.

- 6.3.2.1 Code Reference: The Exception statement in FBC 1507.1.1 and FBC R905.1.1 states: *"...except metal cap nails shall be required where the ultimate design wind speed, V_{ult} , equals or exceeds 150 mph."*

Owens Corning Roofing and Asphalt, LLC has furnished data to permit the use of 1-inch diameter plastic cap nails in lieu of metal cap nails for these applications, when the **RhinoRoof U20** underlayment is installed beneath mechanically fastened prepared roof covers referenced in FBC Table 1507.1.1 or R905.1.1.

6.3.3 Single Layer; Roof Slope > 4:12:

End (vertical) laps shall be minimum 6-inches and side (horizontal) laps shall be minimum 4-inches. Refer to Owens Corning Roofing and Asphalt, LLC recommendations for alternate lap configurations and/or the use of sealant under certain conditions.

For exposure \leq 24 hours, use of every-other fastening location printed on the surface is acceptable. For exposure > 24 hours up to maximum 30-days, use of every fastening location printed on the surface is required.

When batten systems are to be installed atop the underlayment, the underlayment need only be preliminarily attached pending attachment of the battens on the same day. Battens shall not be positioned over cap nails. If this occurs, remove the cap nail and patch the hole in accordance with Owens Corning Roofing and Asphalt, LLC published instructions.

6.3.4 Double Layer; 2:12 < Roof Slope < 4:12:

End (vertical) laps shall be minimum 12-inches and side (horizontal) laps shall be minimum half-sheet-width plus 1-inch.

Double layer application; begin by fastening a half-width plus 1-inch starter strip along the eaves. Place a full-width sheet over the starter, completely overlapping the starter course. Continue as noted in 6.3.3, but maintaining minimum half-width plus 1-inch side (horizontal) laps, resulting in a double-layer application.



NEMO|etc.

7. BUILDING PERMIT REQUIREMENTS:

As required by the Building Official or Authority Having Jurisdiction in order to properly evaluate the installation of this product.

8. MANUFACTURING PLANTS:

Qingdao, China

9. QUALITY ASSURANCE ENTITY:

Intertek Testing Services NA Inc. – QUA1673; (608) 836-4400

- END OF EVALUATION REPORT -



- Searches
- Sales Search
- Results
- Property Record Card**
- My Favorites

Sign up for e-Notify...

5114 Gramont Ave < 17-23-30-4379-01-670 >

Name(s): Cargo Dennis
 Cargo Ann Marie
 Mailing Address: On File
 5114 Gramont Ave
 Belle Isle, FL 32812-1012
 Incorrect Mailing Address:

Physical Street Address: 5114 Gramont Ave
 Postal City and Zipcode: Orlando, FL 32812
 Property Use: 0103 - Single Fam Class III
 Municipality: Belle Isle



View 2018 Property Record Card

- Property Features
- Values, Exemptions and Taxes**
- Sales Analysis
- Location Info
- Market Stats
- Update Information

2019 values will be available in August of 2019.

Property Description

LAKE CONWAY ESTATES SECTION 3 Y/19 LOT 167

[View Plat](#)

Total Land Area 11,218 sqft (+/-) | 0.26 acres (+/-) GIS Calculated Notice

Land

Land Use Code	Zoning	Land Units	Unit Price	Land Value	Class Unit Price	Class Value
0100 - Single Family	R-1-AA	1 LOT(S)	working...	working...	working...	working...

Page 1 of 1 (1 total records)

Buildings

Important Information		Structure			
	Model Code: 01 - Single Fam Residence	Actual Year Built: 1962	Gross Area: 3503 sqft		
	Type Code: 0103 - Single Fam Class III	Beds: 5	Living Area: 2265 sqft		
	Building Value: working...	Baths: 3.0	Exterior Wall: Concrete/Cinder Block		
	Estimated New Cost: working...	Floors: 2	Interior Wall: Drywall		

Page 1 of 1 (1 total records)

Extra Features

Description	Date Built	Units	XFOB Value
FPL2 - Average Fireplace	01/01/1962	1 Unit(s)	working...
PT2 - Patio 2	01/01/2010	1 Unit(s)	working...

Page 1 of 1 (2 total records)

This Data Printed on 07/24/2019 and System Data Last Refreshed on 07/23/2019



RICK SCOTT, GOVERNOR

JONATHAN ZACHEM, SECRETARY



**STATE OF FLORIDA
DEPARTMENT OF BUSINESS AND PROFESSIONAL REGULATION**

CONSTRUCTION INDUSTRY LICENSING BOARD

THE ROOFING CONTRACTOR HEREIN IS CERTIFIED UNDER THE
PROVISIONS OF CHAPTER 489, FLORIDA STATUTES

LASCHOB, GERALD RAYMOND

JA EDWARDS OF AMERICA, INC.
220 WEBER ST.
ORLANDO FL 32803

LICENSE NUMBER: CCC057521

EXPIRATION DATE: AUGUST 31, 2020

Always verify licenses online at MyFloridaLicense.com



Do not alter this document in any form.

This is your license. It is unlawful for anyone other than the licensee to use this document.

2018 - 2019



Local Business Tax Receipt

(Formerly known as "Business License"
changed per state law HB1289-2006)

Business Name

JA EDWARDS OF AMERICA INC GERALD R
LASCHOBBER CCC057521
220 WEBER STREET
ORLANDO, FL 32803

Business Owner

JA EDWARDS OF AMERICA INC

Business Location

220 WEBER ST
ORLANDO, FL

NOTICE-THIS TAX RECEIPT ONLY EVIDENCES
PAYMENT OF THE LOCAL BUSINESS TAX PURSUANT
TO CH.205, FLORIDA STATUTES. IT DOES NOT PERMIT
THE HOLDER TO OPERATE IN VIOLATION OF ANY CITY,
STATE, OR FEDERAL LAW. CITY PERMITTING MUST BE
NOTIFIED OF ANY MATERIAL CHANGE TO THE
INFORMATION FOUND HEREIN BELOW. THIS RECEIPT
DOES NOT CONSTITUTE AN ENDORSEMENT OR
APPROVAL OF THE HOLDER'S SKILL OR
COMPETENCY.

Case Number: BUS-1009509

Issued Date: 07/13/2018

Expiration Date: 09/30/2019

Business type(s)

Description

Year

CONTRA 1524 CONTRACTOR DBPR

2019



Local Business Tax Receipt

City Hall, 400 South Orange Avenue, First Floor
Post Office Box 4990
Orlando, Florida 32802-4990

Phone: 407.246.2204 Fax: 407.246.3420

Email: BusinessTax@cityoforlando.net

Prompt Interactive Voice Response System: 407.246.4444
Visit our website: cityoforlando.net/permits

Tax Collector Scott Randolph**Local Business Tax Receipt****Orange County, Florida**

This local Business Tax Receipt is in addition to and not in lieu of any other tax required by law or municipal ordinance. Businesses are subject to regulation of zoning, health and other lawful authorities. This receipt is valid from October 1 through September 30 of receipt year. Delinquent penalty is added October 1.

5000 BUSINESS OFFICE	2018	EXPIRES 9/30/2019	5000-1126097
\$30.00	2 EMPLOYEES ;	1806 CERTIFIED ROOFING CO	\$30.00 1 EMPLOYEE ;

TOTAL TAX	\$80.00
PREVIOUSLY PAID	\$80.00
TOTAL DUE	\$0.00



EDWARDS JORDAN PRESIDENT
 LASCHNER GERALD RAYMOND QUALIFIER
 JA EDWARDS OF AMERICA INC
 EDWARDS JORDAN
 220 WEBER ST
 ORLANDO FL 32803

220 WEBER ST
 A - ORLANDO, 32803
 CCC057521

PAID: \$80.00 2502-04147171 7/19/2018

This receipt is official when validated by the Tax Collector.

Orange County Code requires this local Business Tax Receipt to be displayed conspicuously at the place of business in public view. It is subject to inspection by all duly authorized officers of the County.

