



City of Belle Isle Job Site Card **Roof PERMIT** 2019-07-075

PERMIT MUST BE POSTED ON SITE - A permit expires in 6 months if approved inspections are not recorded /scheduled within that time frame. You are responsible for scheduling and keeping track of all your inspections -

Permit Number: 2019- 07-075

Issue Date: 08/08/2019

Site Address: 4221 Bell Tower Ct 32812

Parcel #: 20-23-30-1618-00-510

Class: Residential **Subdivision:**

Description of Work: Roof Square Footage: 3750 ASPHALT SHINGLES with underlayment

Number of Stories:2

Issued: ONE WORLD ROOFING LLC

Business Phone: 407 765-2118

Name: HECTOR, YORDANYS

Contractor License: CCC1330134

Payment Date & Method: 8/12/2019 Picked up or sent by _____ Emailed

Visa Master Card Amex Discover Check / Money Order # 8179

Schedule Inspections via Email at: BD scheduling@universalengineering.com

SCHEDULE INSPECTIONS BY 3:00 PM CUT OFF TIME

Inspection Results Will Be Sent Out the Following Business Day

"WARNING TO OWNER: YOUR FAILURE TO RECORD A NOTICE OF COMMENCEMENT MAY RESULT IN YOUR PAYING TWICE FOR IMPROVEMENTS TO YOUR PROPERTY. IF YOU INTEND TO OBTAIN FINANCING, CONSULT WITH YOUR LENDER OR AN ATTORNEY BEFORE RECORDING YOUR NOTICE OF COMMENCEMENT."

ROOF	INSPECTOR	DATE	COMMENTS
NEW ROOFS ONLY Code 700 Deck Nailing, Dry-In, Flashing			This inspection only applies for a brand new roof only!
Both new & re-roof Code 710 In - Progress			This inspection consists of all underlayment/black paper coverage and only 25% shingle coverage .
Both new & re-roof Code 720 Final			After the In Progress has been passed, then the entire roof is covered with shingles.

Inspection requests are to be emailed to BD scheduling@UniversalEngineering.com; a confirmation email will be sent back to you upon scheduling. **Next-Day Inspection requests must be made by 3:00 p.m.** Please include the following in your request: Permit #, project address, type of inspection, date of the requested inspection, a contact name & a contact phone number. AM or PM may be requested but cannot be guaranteed. **OSHA Approved Access to the Roof must be made Available to the Inspector.**



City of Belle Isle
 Universal Engineering Sciences 3532 Maggie Blvd., Orlando, FL 32811
 Tel 407-581-8161 * Fax 407-581-0313 * www.universalengineering.com

RECEIVED AUG - 8 2019

APPLICATION FOR ROOFING PERMIT

WARNING TO OWNER: YOUR FAILURE TO RECORD A NOTICE OF COMMENCEMENT MAY RESULT IN YOUR PAYING TWICE FOR IMPROVEMENTS TO YOUR PROPERTY. A NOTICE OF COMMENCEMENT MUST BE RECORDED AND POSTED ON THE JOB SITE BEFORE THE FIRST INSPECTION. IF YOU INTEND TO OBTAIN FINANCING, CONSULT WITH YOUR LENDER OR AN ATTORNEY BEFORE RECORDING YOUR NOTICE OF COMMENCEMENT.

DATE OF APPLICATION: 8-8-19 ROOF PERMIT NUMBER 2019-07-075
 PLEASE PRINT. The undersigned hereby applies for a permit to make installations as indicated below:

Project Address 4221 Bell Tower ct, Belle Isle, FL 32809 32812
 Property Owner Hemchander Lall Phone 321-304-1225
 Property Owner's Mailing Address 12438 Greco Dr City Orlando
 State FL Zip Code 32824 Parcel Id Number: 202330161800510
 REQUIRED! To obtain this information, please visit <http://www.ocpaf.org/Searches/ParcelSearch.aspx>

Class of Building: Old New Type of Building: Residential Commercial Other
 Type of Work: New Roof ReRoof

- **REQUIRED!** Florida Product Approval Form – NOTE: installation instructions must be posted on-site before your first inspection!!
- OSHA Approved Access to the Roof must be made Available to the Inspector

Please indicate the nature of work by completing the information below:
 Roof Square Footage: 3750 Number of Stories: 2 Job Valuation: \$ 10,750 ^{15 = 11,250} _{9%}
 Type: Asphalt Shingles Metal Modified Bitumen Other: _____

I hereby certify that the above is true and correct to the best of my knowledge and make Application for Permit as outlined above, and if same is granted I agree to conform to all Florida Building Code Regulations and City Ordinances regulating same and in accordance with plans submitted. The issuance of this permit does not grant permission to violate any applicable Town and/or State of Florida codes and/or ordinances. By signing below, I recognize Republic Services is by legal contract the sole authorized provider of garbage, recycling, yard waste, and commercial garbage and construction debris collection and disposal services with the city limits of the City. Contractors, homeowners and commercial businesses may contact Republic Services at 407-293-8000 to setup accounts for Commercial, Construction Roll Off, or other services needed. Rates are fixed by contract and are available at City Hall or from Republic Services. The City enforces the contract through its code enforcement office. Failure to comply will result in a stop work order.

LICENSE HOLDER SIGNATURE [Signature] LICENSE # CCC1330134
 LICENSE HOLDER NAME Jordanys Hector COMPANY NAME one world roofing
 Street Address 390 N. Orange Ave
 City Orlando State FL Zip Code 32801 Phone Number 407-765-2118
 Email Address oceroofing@icloud.com

Building Official: [Signature] Date 8-8-19
 Verified Contractor's Licenses & Insurance are on file [Signature] Date 8-8-19

Zoning Fee	\$ <u>30.-</u>
Building Fee	\$ <u>80.-</u>
Review Fee	\$ <u>0</u>
1% BCAIB Fee	\$ <u>2.- min</u>
1.5% DCA Fee	\$ <u>2.- min</u>
Total Permit Fee	\$ <u>114.-</u>

NOTE: The Building Permit Number is required if the Roof Installation is associated with any construction or alteration where a Building Permit has been issued.
 Building Permit Number _____

Record Notarized Document at OC Comptroller's Office - 109 E. Church Street, Suite 300, Orlando

Permit Number: _____
 Folio/Parcel Identification Number: 202330161800510
 Prepared by: _____

DOCM 20190439087
 07/17/2019 02:28:49 PM Page 1 of 1
 Rec Fee: \$10.00
 Phil Diamond, Comptroller
 Orange County, FL
 IP - Ret To: HEMCHANDER HALL

Return to: _____



NOTICE OF COMMENCEMENT

State of Florida, County of Orange

The undersigned hereby gives notice that improvement will be made to certain real property, and in accordance with Chapter 713, Florida Statutes, the following information is provided in this Notice of Commencement.

1. **Description of property** (legal description of the property, and street address if available)
4221 Bell Tower Ct. Belle Isle 32812
2. **General description of improvement**
Re-roof
3. **Owner information or Lessee information if the Lessee contracted for the improvement**
 Name Hemchander Kall
 Address 12438 Green Dr Orlando FL 32824
 Interest in Property _____
Name and address of fee simple titleholder (if different from Owner listed above)
 Name _____
 Address _____
4. **Contractor**
 Name Home owner Telephone Number 321-304-1225
 Address _____
5. **Surety** (if applicable, a copy of the payment bond is attached)
 Name _____ Telephone Number _____
 Address _____ Amount of Bond \$ _____
6. **Lender**
 Name _____ Telephone Number _____
 Address _____
7. **Persons within the State of Florida designated by Owner upon whom notices or other documents may be served as provided by §713.13(1)(a)7, Florida Statutes.**
 Name _____ Telephone Number _____
 Address _____
8. **In addition to himself or herself, Owner designates the following to receive a copy of the Lienor's Notice as provided in §713.13(1)(b), Florida Statutes.**
 Name _____ Telephone Number _____
 Address _____
9. **Expiration date of notice of commencement** (the expiration date may not be before the completion of construction and final payment to the contractor, but will be 1 year from the date of recording unless a different date is specified)

WARNING TO OWNER: ANY PAYMENTS MADE BY THE OWNER AFTER THE EXPIRATION OF THE NOTICE OF COMMENCEMENT ARE CONSIDERED IMPROPER PAYMENTS UNDER CHAPTER 713, PART I, SECTION 713.13, FLORIDA STATUTES, AND CAN RESULT IN YOUR PAYING TWICE FOR IMPROVEMENTS TO YOUR PROPERTY. A NOTICE OF COMMENCEMENT MUST BE RECORDED AND POSTED ON THE JOB SITE BEFORE THE FIRST INSPECTION. IF YOU INTEND TO OBTAIN FINANCING, CONSULT WITH YOUR LENDER OR AN ATTORNEY BEFORE COMMENCING WORK OR RECORDING YOUR NOTICE OF COMMENCEMENT.

Under penalty of perjury, I declare that I have read the foregoing notice of commencement and that the facts stated in it are true to the best of my knowledge and belief.

Hemchander Kall Signature of Owner or Lessee, or Owner's or Lessee's Authorized Officer/Director/Partner/Manager
owner Signatory's Title/Office

The foregoing instrument was acknowledged before me this 17 day of 07/19 by Hemchander Kall
 as owner for 12438 Green Dr Orlando FL 32824
Type of authority, e.g., officer, trustee, attorney in fact month/year name of person
Name of party on behalf of whom instrument was executed

Kenneth Wilson Signature of Notary Public - State of Florida
 Print, type, or stamp commissioned name of Notary Public

Personally Known OR Produced ID
 Type of ID Produced FL DL



State of FLORIDA, County of ORANGE
 I hereby certify that this is a true copy of the document as reflected in the Official Records
 PHIL DIAMOND, COUNTY COMPTROLLER
 BY: [Signature], D.C.
 DATED: JUL 17 2019





City of Belle Isle

Universal Engineering Sciences 3532 Maggie Blvd., Orlando, FL 32811
 Tel 407-581-8161 * Fax 407-581-0313 * www.universalengineering.com

Product Approval Form

DATE: 7-25-19

32812

PERMIT # _____

PROJECT ADDRESS 4221 Bell Tower ct Belle Isle, Belle Isle, FL 32809 32812

As required by Florida Statue 553.842 and Florida Administrative Code 9B-72m, please provide the information and approval numbers of the building components listed below if they will be utilized on the building or structure. FL Approved products are listed online at www.floridabuilding.org or can be obtained from the local product supplier. The following information must be turned in with permit application and available onsite for inspections:

1. This Product Approval Cover Sheet
2. Internet screen from FloridaBuilding.org showing PA#, approval and code edition stamped
3. Manufacturer's installation details from FloridaBuilding.org and requirements for each product stamped

Product Type	Manufacturer	Model/Series	FL Product Approval #	Product Type	Manufacturer	Model/Series	FL Product Approval #
EXTERIOR DOORS				WALL PANELS			
Swinging				Sliding			
Sliding				Soffits			
Sectional/Rollup				Storefront			
Other				Glass Block			
				Other			
WINDOWS				ROOFING PRODUCTS			
Single/Dbf Hung				Asphalt Shingles	GAF		FL10124-R20
Horizontal Slider				Non Struct Metal			
Casement				Roofing Tiles			
Fixed				Single Ply Roof			
Mullion				Underlayment	GAF		FL18686-R3
Skylights				Other			
Other							
STRUCTURAL COMPONENTS				OTHER			
Wood Connectors							
Wood Anchors							
Truss Plates							
Insulation Forms							
Lintels							
Other							

It is the applicant's responsibility to verify that specific products have been installed in accordance with their limitations and with the minimum required design pressures for the structure. Specific compliance will be verified during field inspections.

Applicant Signature Hemelanda Hall

Date 7-25-19



[DBPR HOME](#) | [ABOUT DBPR](#) | [DBPR DIVISIONS](#) | [CONTACT DBPR](#)

[BCIS Home](#) | [Log In](#) | [User Registration](#) | [Hot Topics](#) | [Submit Surcharge](#) | [Stats & Facts](#) | [Publications](#) | [Contact Us](#) | [BCIS Site Map](#) | [Links](#) | [Search](#)



Product Approval
USER: Public User

[Product Approval Menu](#) > [Product or Application Search](#) > [Application List](#) > **Application Detail**



FL #	FL10124-R22												
Application Type	Revision												
Code Version	2017												
Application Status	Approved												
Comments													
Archived	<input type="checkbox"/>												
Product Manufacturer	GAF												
Address/Phone/Email	1 Campus Drive Parispany, NJ 07054 (800) 766-3411 mstieh@gaf.com												
Authorized Signature	Robert Nieminen lireith@nemoetc.com												
Technical Representative	William Broussard												
Address/Phone/Email	1 Campus Drive Parsippany, NJ 07054 (800) 766-3411 TechnicalQuestionsGAF@gaf.com												
Quality Assurance Representative													
Address/Phone/Email													
Category	Roofing												
Subcategory	Asphalt Shingles												
Compliance Method	Evaluation Report from a Florida Registered Architect or a Licensed Florida Professional Engineer <input type="checkbox"/> Evaluation Report - Hardcopy Received												
Florida Engineer or Architect Name who developed the Evaluation Report	Robert Nieminen												
Florida License	PE-59166												
Quality Assurance Entity	UL LLC												
Quality Assurance Contract Expiration Date	10/18/2021												
Validated By	John W. Knezevich, PE <input checked="" type="checkbox"/> Validation Checklist - Hardcopy Received												
Certificate of Independence	FL10124_R22_COI_2019_01_COI_NIEMINEN.pdf												
Referenced Standard and Year (of Standard)	<table border="0"> <thead> <tr> <th>Standard</th> <th>Year</th> </tr> </thead> <tbody> <tr> <td>ASTM D1970</td> <td>2015</td> </tr> <tr> <td>ASTM D3161</td> <td>2016</td> </tr> <tr> <td>ASTM D3462</td> <td>2010</td> </tr> <tr> <td>ASTM D7158</td> <td>2011</td> </tr> <tr> <td>TAS 107</td> <td>1995</td> </tr> </tbody> </table>	Standard	Year	ASTM D1970	2015	ASTM D3161	2016	ASTM D3462	2010	ASTM D7158	2011	TAS 107	1995
Standard	Year												
ASTM D1970	2015												
ASTM D3161	2016												
ASTM D3462	2010												
ASTM D7158	2011												
TAS 107	1995												
Equivalence of Product Standards Certified By													
Sections from the Code													

Product Approval Method	Method 1 Option D
Date Submitted	04/17/2019
Date Validated	04/21/2019
Date Pending FBC Approval	04/25/2019
Date Approved	06/18/2019

Summary of Products

FL #	Model, Number or Name	Description
10124.1	GAF Asphalt Roof Shingles	Fiberglass reinforced 3-tab, laminated, 5-tab and hip/ridge asphalt shingles
Limits of Use Approved for use in HVHZ: No Approved for use outside HVHZ: Yes Impact Resistant: N/A Design Pressure: N/A Other: Refer to ER, Section 5.		Installation Instructions FL10124 R22 II 2019 04 FINAL ER GAF ASPHALT SHINGLES FL10124-R22.pdf Verified By: Robert Nieminen PE-59166 Created by Independent Third Party: Yes Evaluation Reports FL10124 R22 AE 2019 04 FINAL ER GAF ASPHALT SHINGLES FL10124-R22.pdf Created by Independent Third Party: Yes

[Back](#) [Next](#)

Contact Us :: [2601 Blair Stone Road, Tallahassee FL 32399](#) Phone: 850-487-1824

The State of Florida is an AA/EEO employer. [Copyright 2007-2013 State of Florida](#). :: [Privacy Statement](#) :: [Accessibility Statement](#) :: [Refund Statement](#)

Under Florida law, email addresses are public records. If you do not want your e-mail address released in response to a public-records request, do not send electronic mail to this entity. Instead, contact the office by phone or by traditional mail. If you have any questions, please contact 850.487.1395. *Pursuant to Section 455.275 (1), Florida Statutes, effective October 1, 2012, licensees licensed under Chapter 455, F.S. must provide the Department with an email address if they have one. The emails provided may be used for official communication with the licensee. However email addresses are public record. If you do not wish to supply a personal address, please provide the Department with an email address which can be made available to the public. To determine if you are a licensee under Chapter 455, F.S., please [click here](#).

Product Approval Accepts:



Credit Card
Safe





NEMO|etc.

Certificate of Authorization #32455
353 Christian Street, Unit #13
Oxford, CT 06478
(203) 262-9245

ENGINEER

EVALUATE

TEST

CONSULT

CERTIFY

EVALUATION REPORT

GAF

1 Campus Drive
Parsippany, NJ 07054
(800) 766-3411

Evaluation Report 01506.01.08-R24

FL10124-R22

Date of Issuance: 01/03/2008

Revision 24: 04/12/2019

SCOPE:

This Evaluation Report is issued under **Rule 61G20-3** and the applicable rules and regulations governing the use of construction materials in the State of Florida. The documentation submitted has been reviewed by Robert Nieminen, P.E. for use of the product under the Florida Building Code and Florida Building Code, Residential Volume. The products described herein have been evaluated for compliance with the **6th Edition (2017) Florida Building Code** sections noted herein.

DESCRIPTION: GAF Asphalt Roof Shingles

LABELING: Labeling shall be in accordance with the requirements of the Accredited Quality Assurance Agency noted herein and **FBC 1507.2.7.1 / R905.2.6.1**

CONTINUED COMPLIANCE: This Evaluation Report is valid until the named product(s) changes, the referenced Quality Assurance documentation changes, or provisions of the Code that relate to the product change. Acceptance of this Evaluation Report by the named client constitutes agreement to notify Robert Nieminen, P.E. of any changes to the product(s), the Quality Assurance or the production facility location(s). NEMO|etc. requires a complete review of this Evaluation Report relative to updated Code requirements with each Code Cycle.

ADVERTISEMENT: The Evaluation Report number preceded by the words "NEMO|etc. Evaluated" may be displayed in advertising literature. If any portion of the Evaluation Report is displayed, then it shall be done in its entirety.

INSPECTION: Upon request, a copy of this entire Evaluation Report shall be provided to the user by the manufacturer or its distributors and shall be available for inspection at the job site at the request of the Building Official.

This Evaluation Report consists of pages 1 through 6.

Prepared by:

Robert J.M. Nieminen, P.E.

Florida Registration No. 59166, Florida DCA ANE1983



The facsimile seal appearing was authorized by Robert Nieminen, P.E. on 04/12/2019. This does not serve as an electronically signed document.

CERTIFICATION OF INDEPENDENCE:

1. NEMO|etc. does not have, nor does it intend to acquire, or will it acquire, a financial interest in any company manufacturing or distributing products it evaluates.
2. NEMO|etc. is not owned, operated or controlled by any company manufacturing or distributing products it evaluates.
3. Robert Nieminen, P.E. does not have nor will acquire, a financial interest in any company manufacturing or distributing products for which the evaluation reports are being issued.
4. Robert Nieminen, P.E. does not have, nor will acquire, a financial interest in any other entity involved in the approval process of the product.
5. This is a building code evaluation. Neither NEMO|etc. nor Robert Nieminen, P.E. are, in any way, the Designer of Record for any project on which this Evaluation Report, or previous versions thereof, is/was used for permitting or design guidance unless retained specifically for that purpose.

ROOFING SYSTEMS EVALUATION:
1. SCOPE:
Product Category: Roofing

Sub-Category: Asphalt Shingles

Compliance Statement: GAF Asphalt Roof Shingles, as produced by GAF, have demonstrated compliance with the following sections of the 6th Edition (2017) Florida Building Code and Florida Building Code, Residential Volume through testing in accordance with the following Standards. Compliance is subject to the Installation Requirements and Limitations / Conditions of Use set forth herein.

2. STANDARDS:

<u>Section</u>	<u>Property</u>	<u>Standard</u>	<u>Year</u>
1507.2.4, R905.2.3	Physical Properties	ASTM D1970	2015
1507.2.5, R905.2.4	Physical Properties	ASTM D3462	2010
1507.2.7.1, R905.2.6.1	Wind Resistance	ASTM D3161	2016
1507.2.7.1, R905.2.6.1	Wind Resistance	ASTM D7158	2011
1507.2.7.1, R905.2.6.1	Wind Resistance	TAS 107	1995

3. REFERENCES:

<u>Entity</u>	<u>Examination</u>	<u>Reference</u>	<u>Date</u>
PRI (TST 5878)	Physical Properties	GAF-025-02-01	03/27/2002
PRI (TST 5878)	ASTM D3462	GAF-059-02-01	09/02/2004
PRI (TST 5878)	ASTM D3462	GAF-080-02-01	05/25/2005
PRI (TST 5878)	Physical Properties	GAF-324-02-01	12/01/2011
PRI (TST 5878)	ASTM D1970 (QuickStart)	GAF-340-02-01	03/13/2012
PRI (TST 5878)	Wind Driven Rain	GAF-407-02-01	01/21/2013
PRI (TST 5878)	Wind Driven Rain	GAF-895-02-01	11/20/2018
PRI (TST 5878)	Wind Driven Rain	GAF-896-02-01	11/20/2018
PRI (TST 5878)	ASTM D3462	GAF-897-02-01	11/08/2018
PRI (TST 5878)	ASTM D3462	GAF-898-02-01	11/08/2018
PRI (TST 5878)	ASTM D3462	GAF-899-02-01	11/15/2018
UL (TST 1740)	ASTM D3462	93NK6295	11/29/1993
UL (TST 1740)	ASTM D3462	99NK43835	01/12/2000
UL (TST 1740)	TAS 107	94NK9632	03/29/2000
UL (TST 1740)	ASTM D3462	01NK06632	02/02/2001
UL (TST 1740)	ASTM D3161, TAS 107	01NK9226	05/21/2001
UL (TST 1740)	ASTM D3161	01NK37122	12/18/2001
UL (TST 1740)	ASTM D3462	01NK37122	12/19/2001
UL (TST 1740)	ASTM D3161, TAS 107	02NK12980	04/10/2002
UL (TST 1740)	ASTM D3161, TAS 107	02NK30871	09/09/2002
UL (TST 1740)	ASTM D3161	03CA5367	03/11/2003
UL (TST 1740)	ASTM D3462	03NK26444	10/17/2003
UL (TST 1740)	ASTM D3462	04NK13850	06/07/2004
UL (TST 1740)	ASTM D3161	04NK13850	06/23/2004
UL (TST 1740)	ASTM D3161	04NK30546	03/10/2005
UL (TST 1740)	ASTM D3462	04NK22009	05/06/2005
UL (TST 1740)	ASTM D3161	04NK22009	05/09/2005
UL (TST 1740)	ASTM D3462	05NK27924	02/10/2006
UL (TST 1740)	ASTM D3161	05NK27924	02/11/2006
UL (TST 1740)	ASTM D3161, D3462	06CA18077	06/05/2006
UL (TST 1740)	ASTM D3161, D3462	06CA18074	06/16/2006
UL (TST 1740)	ASTM D3161, D3462	06CA35251	10/18/2006
UL (TST 1740)	ASTM D3462	06CA31603	12/01/2006
UL (TST 1740)	ASTM D3161, D3462	06CA41095	12/27/2006
UL (TST 1740)	ASTM D3161	07NK05228	03/13/2007



<u>Entity</u>	<u>Examination</u>	<u>Reference</u>	<u>Date</u>
UL (TST 1740)	ASTM D3161	06CA31611	04/04/2007
UL (TST 1740)	ASTM D3161	06CA61148	04/09/2007
UL (TST 1740)	ASTM D3161, D3462	07CA31742	11/08/2007
UL (TST 1740)	ASTM D3161, D7158, D3462	08CA06100	03/13/2008
UL, LLC. (TST 9628)	ASTM D3161	4788698165	03/24/2008
UL (TST 1740)	ASTM D3161, D3462	07CA55908	04/01/2008
UL (TST 1740)	ASTM D3161, D3462	09CA10592	03/26/2009
UL (TST 1740)	ASTM D3161, D3462	09CA06856	05/15/2009
UL (TST 1740)	ASTM D3161, D7158, D3462	09NK06647	08/01/2009
UL (TST 1740)	ASTM D3161, D7158, D3462	09CA27281	08/27/2009
UL (TST 1740)	ASTM D3161, D7158, D3462	10CA35554	03/05/2010
UL (TST 1740)	ASTM D3161, D7158, D3462	10CA13686	05/15/2010
UL (TST 1740)	ASTM D3462	10CA07264	05/27/2010
UL (TST 1740)	ASTM D3462	10CA11953	10/29/2010
UL (TST 1740)	ASTM D3161, D7158, D3462	10NK11951	10/30/2010
UL (TST 1740)	ASTM D3161, D7158, D3462	10NK12070	11/04/2010
UL (TST 1740)	ASTM D3161, D7158, D3462	08CA06100	01/30/2010
UL (TST 1740)	ASTM D3161, D7158, D3462	10CA53934	03/31/2011
UL (TST 1740)	ASTM D3161, D7158, D3462	11CA48924	10/22/2011
UL (TST 1740)	ASTM D3161, D7158, D3462	11CA47919	12/03/2011
UL (TST 1740)	ASTM D3161, D7158, D3462	11CA48408	12/08/2011
UL (TST 1740)	ASTM D3161, D7158, D3462	11CA48725	12/09/2011
UL, LLC. (TST 9628)	ASTM D3462	12CA34891	10/12/2012
UL, LLC. (TST 9628)	ASTM D3161, D7158, D3462	12CA58151	02/15/2013
UL, LLC. (TST 9628)	ASTM D3161	12CA38083	02/26/2013
UL, LLC. (TST 9628)	ASTM D3161	13CA32332	06/18/2013
UL, LLC. (TST 9628)	ASTM D3161	13CA37934	08/02/2013
UL, LLC. (TST 9628)	ASTM D3161, D7158, D3462	4786875675	07/17/2015
UL, LLC. (TST 9628)	ASTM D3161, D7158, D3462	4787434542	05/17/2016
UL, LLC. (TST 9628)	ASTM D3161, D7158, D3462	4788717529	09/09/2016
UL, LLC. (TST 9628)	ASTM D3161	4788669132	12/13/2018
UL, LLC. (TST 9628)	ASTM D3161	4788891098	02/14/2019
UL, LLC. (QUA 9625)	Quality Control	Service Confirmation	10/18/2018

4. PRODUCT DESCRIPTION:

4.1 ACCESSORY STARTER STRIPS:

- 4.1.1 Pro-Start® Eave/Rake Starter Strip Shingles and WeatherBlocker™ Premium Eave/Rake Starter Strip Shingles are starter strips for asphalt roof shingles. Meets ASTM D3462.
- 4.1.2 QuickStart® Peel & Stick Starter Roll is a mineral-surfaced, fiberglass-reinforced, self-adhering SBS modified bitumen starter strip, nominal 9-inch x 33 ft roll, for use with asphalt shingles with exposure of 6-inch or less. Meets ASTM D1970.
- 4.1.3 StarterMatch™ Starter Strip Shingles are color-coordinated starter strips for use with Grand Canyon® and Grand Sequoia® series asphalt shingles. StarterMatch™ are installed as the second starter for Grand Canyon® and Grand Sequoia® series installations. Meets ASTM D3462.

4.2 ASPHALT SHINGLES:

- 4.2.1 Marquis WeatherMax®, Royal Sovereign® and Sentinel® are a fiberglass reinforced 3-tab asphalt roof shingles.
- 4.2.2 Camelot®, Camelot® II, Fortitude™, Glenwood™, Grand Canyon®, Grand Sequoia®, Grand Sequoia® IR, Grand Sequoia® ArmorShield™, Sienna®, Timberline® American Harvest®, Timberline® ArmorShield™ II, Timberline® Natural Shadow®, Timberline HD®, Timberline® HDZ™, Timberline® Cool Series®, Timberline Ultra HD® and Woodland® are fiberglass reinforced, laminated asphalt roof shingles.
- 4.2.3 Slateline® is a fiberglass reinforced 5-tab asphalt roof shingle.



4.3 HIP & RIDGE SHINGLES:

- 4.3.1 Seal-A-Ridge® Ridge Cap Shingles, Seal-A-Ridge® ArmorShield™ Ridge Cap Shingles and Timbertex® Premium Ridge Cap Shingles are fiberglass reinforced, hip and ridge asphalt roof shingles.

5. LIMITATIONS:

- 5.1 This is a building code evaluation. Neither NEMO ETC, LLC nor Robert Nieminen, P.E. are, in any way, the Designer of Record for any project on which this Evaluation Report, or previous versions thereof, is/was used for permitting or design guidance unless retained specifically for that purpose.
- 5.2 This Evaluation Report is not for use in FBC HVHZ jurisdictions.
- 5.3 Fire Classification is not part of this Evaluation Report; refer to current Approved Roofing Materials Directory for fire ratings of this product.

5.4 Wind Classification:

- 5.4.1 The GAF asphalt shingles noted in Section 4.2 are Classified in accordance with FBC Tables 1507.2.7.1 and R905.2.6.1 to ASTM D3161, Class F and/or ASTM D7158, Class H, indicating the shingles are acceptable for use in all wind zones up to $V_{asd} = 150$ mph ($V_{ult} = 194$ mph). Refer to Section 6 for installation requirements to meet this wind rating.

Note: Classification by ASTM D7158 applies only to exposure category B or C, as defined in FBC 1609.4.3, and a mean roof height of 60 feet or less. Calculations by a qualified design professional are required for conditions outside these limitations. Contact the shingle manufacturer for data specific to each shingle.

- 5.4.2 The GAF hip & ridge shingles noted in Section 4.3 are Classified in accordance with FBC Tables 1507.2.7.1 and R905.2.6.1 to ASTM D3161, Class F, indicating the shingles are acceptable for use in all wind zones up to $V_{asd} = 150$ mph ($V_{ult} = 194$ mph). Refer to Section 6 for installation requirements to meet this wind rating.
- 5.5 All products in the roof assembly shall have quality assurance audit in accordance with F.A.C. Rule 61G20-3.

6. INSTALLATION:

6.1 GENERAL:

- 6.1.1 Roof deck, slope, underlayment and fasteners shall comply with FBC 1507.2 / R905.2 and the shingle manufacturer's minimum requirements.
- 6.1.2 Underlayment shall be acceptable to GAF and shall hold current Florida Statewide Product Approval, or be Locally Approved per Rule 61G20-3, per FBC Sections 1507.2.3, 1507.2.4 or R905.2.3.
- 6.1.3 Fasteners shall be in accordance with manufacturer's published requirements, but not less than FBC 1507.2.6 or R905.2.5. Staples are not permitted.
- 6.1.4 GAF asphalt shingles are acceptable for use in reroof (tear-off) or recover applications, subject to the limitations set forth in FBC Section 1511 or R908 and CertainTeed published installation instructions.

6.2 STARTER SHINGLES OR STARTER STRIP:

- 6.2.1 Installation of Pro-Start Eave/Rake Starter Strip Shingles, WeatherBlocker Premium Eave/Rake Starter Strip Shingles and QuickStart Peel & Stick Starter Roll shall comply with the GAF current published instructions.

6.3 ASPHALT SHINGLES:

- 6.3.1 Installation of asphalt shingles shall comply with the GAF current published instructions, using minimum four (4) nails per shingle in accordance with FBC 1507.2.7 or R905.2.6, with the following exceptions:
 - Camelot, Camelot II, Grand Canyon, Grand Sequoia, Grand Sequoia IR, Grand Sequoia ArmorShield, and Woodland require minimum five (5) nails per shingle.
 - Slateline requires minimum six (6) nails per shingle.
- 6.3.2 Fasteners shall be in accordance with manufacturer’s published requirements, but not less than FBC 1507.2.6 or R905.2.5. Staples are not permitted.
- 6.3.2.1 Fastening for Timberline® HDZ™; slopes 2:12 up to 21:12

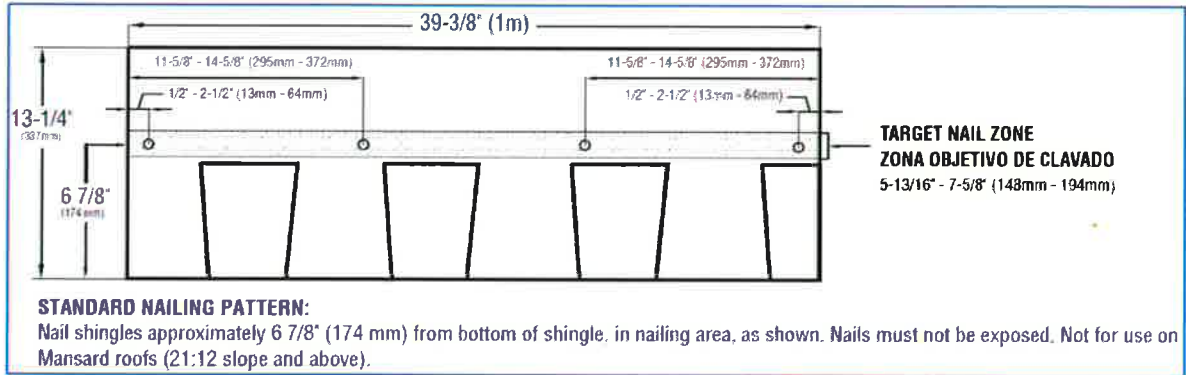

- 6.3.3 Where the roof slope exceeds 21 units vertical in 12 units horizontal, special methods of fastening are required. Contact the GAF for details.
- 6.3.3.1 Fastening for Timberline® HDZ™; slopes greater than 21:12

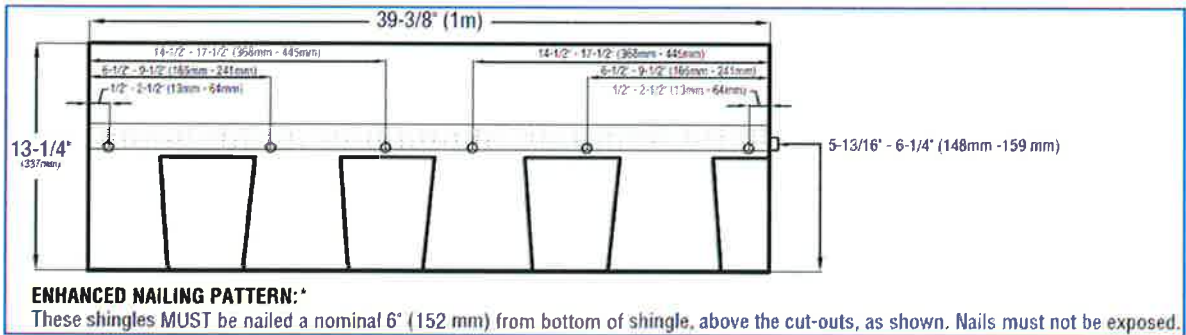

6.4 HIP & RIDGE SHINGLES:

6.4.1 Installation of Seal-A-Ridge Ridge Cap Shingles and Seal-A-Ridge ArmorShield Ridge Cap Shingles shall comply with the GAF current published instructions with a minimum two (2) nails, minimum 3/8-inch head diameter, per shingle and nominal 0.25-inch diameter beads of Henkel “Loctite PL S30 Roof & Flashing Sealant”.

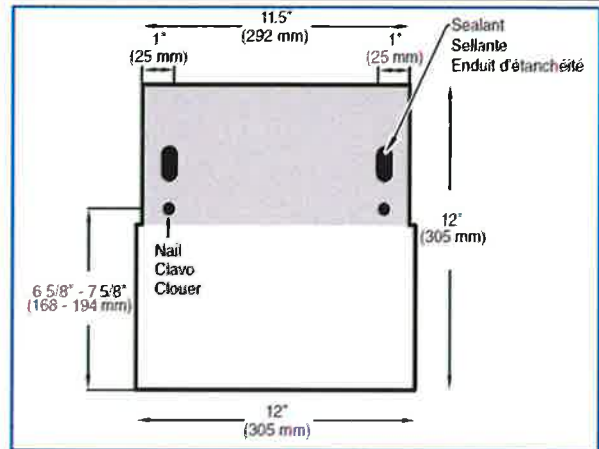

6.4.2 Installation of Timbertex Premium Ridge Cap Shingles shall comply with GAF current published instructions with a minimum two (2) nails, minimum 3/8-inch head diameter, per shingle and beads of Sonneborn “NP1 Gun Grade Polyurethane Sealant” or Henkel “PL Roofing and Flashing Sealant”.

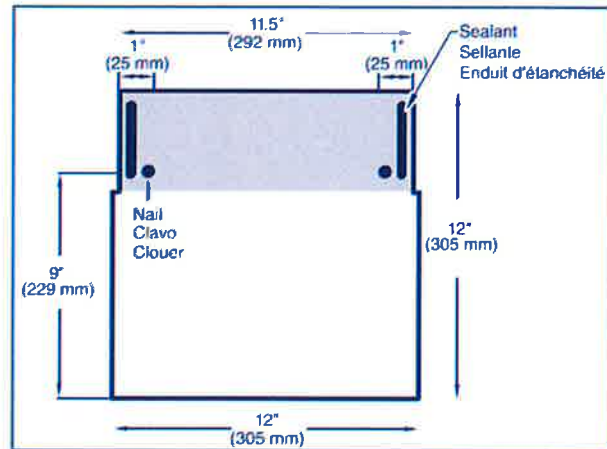

6.4.3 Fasteners shall be in accordance with GAF published requirements, but not less than FBC 1507.2.6 or R905.2.5. Staples are not permitted.

7. LABELING:

- 7.1 Labeling shall be in accordance with the requirements the Accredited Quality Assurance Agency noted herein.
- 7.2 Asphalt shingle wrappers shall indicate compliance with one of the required classifications detailed in **FBC Table 1507.2.7.1 / R905.2.6.1**.

8. BUILDING PERMIT REQUIREMENTS:

As required by the Building Official or Authority Having Jurisdiction in order to properly evaluate the installation of this product.

9. MANUFACTURING PLANTS:

Contact the named QA entity for information on which plants produce products covered by Florida Rule 61G20-3 QA requirements.

10. QUALITY ASSURANCE ENTITY:

UL LLC – QUA9625; (414) 248-6409; karen.buchmann@ul.com

- END OF EVALUATION REPORT -



[BCIS Home](#) | [Log In](#) | [User Registration](#) | [Hot Topics](#) | [Submit Surcharge](#) | [Stats & Facts](#) | [Publications](#) | [Contact Us](#) | [BCIS Site Map](#) | [Links](#) | [Search](#)



Product Approval
USER: Public User

[Product Approval Menu](#) > [Product or Application Search](#) > [Application List](#) > **Application Detail**



FL #	FL10124-R22												
Application Type	Revision												
Code Version	2017												
Application Status	Approved												
Comments													
Archived	<input type="checkbox"/>												
Product Manufacturer	GAF												
Address/Phone/Email	1 Campus Drive Parisppany, NJ 07054 (800) 766-3411 mstieh@gaf.com												
Authorized Signature	Robert Nieminen Ireith@nemoetc.com												
Technical Representative	William Broussard												
Address/Phone/Email	1 Campus Drive Parsippany, NJ 07054 (800) 766-3411 TechnicalQuestionsGAF@gaf.com												
Quality Assurance Representative													
Address/Phone/Email													
Category	Roofing												
Subcategory	Asphalt Shingles												
Compliance Method	Evaluation Report from a Florida Registered Architect or a Licensed Florida Professional Engineer <input type="checkbox"/> Evaluation Report - Hardcopy Received												
Florida Engineer or Architect Name who developed the Evaluation Report	Robert Nieminen												
Florida License	PE-59166												
Quality Assurance Entity	UL LLC												
Quality Assurance Contract Expiration Date	10/18/2021												
Validated By	John W. Knezevich, PE <input checked="" type="checkbox"/> Validation Checklist - Hardcopy Received												
Certificate of Independence	FL10124_R22_COI_2019_01_COI_NIEMINEN.pdf												
Referenced Standard and Year (of Standard)	<table border="0"> <thead> <tr> <th>Standard</th> <th>Year</th> </tr> </thead> <tbody> <tr> <td>ASTM D1970</td> <td>2015</td> </tr> <tr> <td>ASTM D3161</td> <td>2016</td> </tr> <tr> <td>ASTM D3462</td> <td>2010</td> </tr> <tr> <td>ASTM D7158</td> <td>2011</td> </tr> <tr> <td>TAS 107</td> <td>1995</td> </tr> </tbody> </table>	Standard	Year	ASTM D1970	2015	ASTM D3161	2016	ASTM D3462	2010	ASTM D7158	2011	TAS 107	1995
Standard	Year												
ASTM D1970	2015												
ASTM D3161	2016												
ASTM D3462	2010												
ASTM D7158	2011												
TAS 107	1995												
Equivalence of Product Standards Certified By													
Sections from the Code													

Product Approval Method	Method 1 Option D
Date Submitted	04/17/2019
Date Validated	04/21/2019
Date Pending FBC Approval	04/25/2019
Date Approved	06/18/2019

Summary of Products

FL #	Model, Number or Name	Description
10124.1	GAF Asphalt Roof Shingles	Fiberglass reinforced 3-tab, laminated, 5-tab and hip/ridge asphalt shingles
Limits of Use Approved for use in HVHZ: No Approved for use outside HVHZ: Yes Impact Resistant: N/A Design Pressure: N/A Other: Refer to ER, Section 5.		Installation Instructions FL10124 R22 II 2019 04 FINAL ER GAF ASPHALT SHINGLES FL10124-R22.pdf Verified By: Robert Nieminen PE-59166 Created by Independent Third Party: Yes Evaluation Reports FL10124 R22 AE 2019 04 FINAL ER GAF ASPHALT SHINGLES FL10124-R22.pdf Created by Independent Third Party: Yes

[Back](#) [Next](#)

Contact Us :: [2601 Blair Stone Road, Tallahassee FL 32399](#) Phone: 850-487-1824

The State of Florida is an AA/EEO employer. [Copyright 2007-2013 State of Florida](#). :: [Privacy Statement](#) :: [Accessibility Statement](#) :: [Refund Statement](#)

Under Florida law, email addresses are public records. If you do not want your e-mail address released in response to a public-records request, do not send electronic mail to this entity. Instead, contact the office by phone or by traditional mail. If you have any questions, please contact 850.487.1395. *Pursuant to Section 455.275 (1), Florida Statutes, effective October 1, 2012, licensees licensed under Chapter 455, F.S. must provide the Department with an email address if they have one. The emails provided may be used for official communication with the licensee. However email addresses are public record. If you do not wish to supply a personal address, please provide the Department with an email address which can be made available to the public. To determine if you are a licensee under Chapter 455, F.S., please [click here](#).

Product Approval Accepts:



Credit Card
Safe





[BCIS Home](#) | [Log In](#) | [User Registration](#) | [Hot Topics](#) | [Submit Surcharge](#) | [Stats & Facts](#) | [Publications](#) | [Contact Us](#) | [BCIS Site Map](#) | [Links](#) | [Search](#)



Product Approval
USER: Public User

[Product Approval Menu](#) > [Product or Application Search](#) > [Application List](#) > **Application Detail**



FL #	FL18686-R3				
Application Type	Revision				
Code Version	2017				
Application Status	Approved				
	*Approved by DBPR. Approvals by DBPR shall be reviewed and ratified by the POC and/or the Commission if necessary.				
Comments					
Archived	<input type="checkbox"/>				
Product Manufacturer	GAF				
Address/Phone/Email	1 Campus Drive Parsippany, NJ 07054 (800) 766-3411 mstieh@gaf.com				
Authorized Signature	Michael Stieh mstieh@gaf.com				
Technical Representative	Michael Stieh				
Address/Phone/Email	1 Campus Drive Parsippany, NJ 07054 (973) 628-3000 mstieh@gaf.com				
Quality Assurance Representative	Richard Weiman				
Address/Phone/Email	1 Campus Drive Parsippany, NJ 07054 (973) 872-4421 RWeiman@gaf.com				
Category	Roofing				
Subcategory	Underlayments				
Compliance Method	Evaluation Report from a Product Evaluation Entity				
Evaluation Entity	Miami-Dade BCCO - EVL				
Quality Assurance Entity	Miami-Dade BCCO - QUA				
Quality Assurance Contract Expiration Date	02/22/2023				
Validated By	Miami-Dade BCCO - VAL				
Certificate of Independence					
Referenced Standard and Year (of Standard)	<table border="0"> <tr> <td>Standard</td> <td>Year</td> </tr> <tr> <td>ASTM D226</td> <td>2009</td> </tr> </table>	Standard	Year	ASTM D226	2009
Standard	Year				
ASTM D226	2009				
Equivalence of Product Standards Certified By					
Sections from the Code					

Product Approval Method	Method 1 Option C
Date Submitted	02/26/2018
Date Validated	03/16/2018
Date Pending FBC Approval	
Date Approved	03/26/2018

Summary of Products

FL #	Model, Number or Name	Description
18686.1	FeltBuster	High-Traction Synthetic Roofing Felt
Limits of Use Approved for use in HVHZ: Yes Approved for use outside HVHZ: Yes Impact Resistant: No Design Pressure: N/A Other:		Installation Instructions FL18686 R3 II 18-0119.15.pdf Verified By: Miami-Dade BCCO - EVL Created by Independent Third Party: Evaluation Reports FL18686 R3 AE 18-0119.15.pdf

[Back](#) [Next](#)

Contact Us :: [2601 Blair Stone Road, Tallahassee FL 32399](#) Phone: 850-487-1824

The State of Florida is an AA/EEO employer. Copyright 2007-2013 State of Florida. :: [Privacy Statement](#) :: [Accessibility Statement](#) :: [Refund Statement](#)

Under Florida law, email addresses are public records. If you do not want your e-mail address released in response to a public-records request, do not send electronic mail to this entity. Instead, contact the office by phone or by traditional mail. If you have any questions, please contact 850.487.1395. *Pursuant to Section 455.275 (1), Florida Statutes, effective October 1, 2012, licensees licensed under Chapter 455, F.S. must provide the Department with an email address if they have one. The emails provided may be used for official communication with the licensee. However email addresses are public record. If you do not wish to supply a personal address, please provide the Department with an email address which can be made available to the public. To determine if you are a licensee under Chapter 455, F.S., please click [here](#).



Credit Card
Safe





[BCIS Home](#) | [Log In](#) | [User Registration](#) | [Hot Topics](#) | [Submit Surcharge](#) | [Stats & Facts](#) | [Publications](#) | [Contact Us](#) | [BCIS Site Map](#) | [Links](#) | [Search](#)



Product Approval
USER: Public User

[Product Approval Menu](#) > [Product or Application Search](#) > [Application List](#) > **Application Detail**

OFFICE OF THE SECRETARY

FL #	FL18686-R3				
Application Type	Revision				
Code Version	2017				
Application Status	Approved				
	*Approved by DBPR. Approvals by DBPR shall be reviewed and ratified by the POC and/or the Commission if necessary.				
Comments					
Archived					
Product Manufacturer	GAF				
Address/Phone/Email	1 Campus Drive Parsippany, NJ 07054 (800) 766-3411 mstieh@gaf.com				
Authorized Signature	Michael Stieh mstieh@gaf.com				
Technical Representative	Michael Stieh				
Address/Phone/Email	1 Campus Drive Parsippany, NJ 07054 (973) 628-3000 mstieh@gaf.com				
Quality Assurance Representative	Richard Weiman				
Address/Phone/Email	1 Campus Drive Parsippany, NJ 07054 (973) 872-4421 RWeiman@gaf.com				
Category	Roofing				
Subcategory	Underlayments				
Compliance Method	Evaluation Report from a Product Evaluation Entity				
Evaluation Entity	Miami-Dade BCCO - EVL				
Quality Assurance Entity	Miami-Dade BCCO - QUA				
Quality Assurance Contract Expiration Date	02/22/2023				
Validated By	Miami-Dade BCCO - VAL				
Certificate of Independence					
Referenced Standard and Year (of Standard)	<table border="0"> <tr> <td>Standard</td> <td>Year</td> </tr> <tr> <td>ASTM D226</td> <td>2009</td> </tr> </table>	Standard	Year	ASTM D226	2009
Standard	Year				
ASTM D226	2009				
Equivalence of Product Standards Certified By					
Sections from the Code					

Product Approval Method	Method 1 Option C
Date Submitted	02/26/2018
Date Validated	03/16/2018
Date Pending FBC Approval	
Date Approved	03/26/2018

Summary of Products

FL #	Model, Number or Name	Description
18686.1	FeltBuster	High-Traction Synthetic Roofing Felt
Limits of Use Approved for use in HVHZ: Yes Approved for use outside HVHZ: Yes Impact Resistant: No Design Pressure: N/A Other:		Installation Instructions FL18686_R3_II_18-0119.15.pdf Verified By: Miami-Dade BCCO - EVL Created by Independent Third Party: Evaluation Reports FL18686_R3_AE_18-0119.15.pdf

[Back](#) [Next](#)

Contact Us :: [2601 Blair Stone Road, Tallahassee FL 32399](#) Phone: 850-487-1824

The State of Florida is an AA/EEO employer. [Copyright 2007-2013 State of Florida](#). :: [Privacy Statement](#) :: [Accessibility Statement](#) :: [Refund Statement](#)

Under Florida law, email addresses are public records. If you do not want your e-mail address released in response to a public-records request, do not send electronic mail to this entity. Instead, contact the office by phone or by traditional mail. If you have any questions, please contact 850.487.1395. *Pursuant to Section 455.275 (1), Florida Statutes, effective October 1, 2012, licensees licensed under Chapter 455, F.S. must provide the Department with an email address if they have one. The emails provided may be used for official communication with the licensee. However email addresses are public record. If you do not wish to supply a personal address, please provide the Department with an email address which can be made available to the public. To determine if you are a licensee under Chapter 455, F.S., please [click here](#).

Product Approval Accepts:



Credit Card
Safe





DEPARTMENT OF REGULATORY AND ECONOMIC RESOURCES (RER)
BOARD AND CODE ADMINISTRATION DIVISION

MIAMI-DADE COUNTY
PRODUCT CONTROL SECTION

11805 SW 26 Street, Room 208
Miami, Florida 33175-2474

T (786) 315-2590 F (786) 315-2599

www.miamidade.gov/economy

NOTICE OF ACCEPTANCE (NOA)

GAF

1 Campus Drive
Parsipanny, NJ 07054

SCOPE:

This NOA is being issued under the applicable rules and regulations governing the use of construction materials. The documentation submitted has been reviewed and accepted by Miami-Dade County RER - Product Control Section to be used in Miami Dade County and other areas where allowed by the Authority Having Jurisdiction (AHJ).

This NOA shall not be valid after the expiration date stated below. The Miami-Dade County Product Control Section (In Miami Dade County) and/or the AHJ (in areas other than Miami Dade County) reserve the right to have this product or material tested for quality assurance purposes. If this product or material fails to perform in the accepted manner, the manufacturer will incur the expense of such testing and the AHJ may immediately revoke, modify, or suspend the use of such product or material within their jurisdiction. RER reserves the right to revoke this acceptance, if it is determined by Miami-Dade County Product Control Section that this product or material fails to meet the requirements of the applicable building code.

This product is approved as described herein, and has been designed to comply with the Florida Building Code including the High Velocity Hurricane Zone of the Florida Building Code.

DESCRIPTION: GAF Leak Barriers and Roof Deck Protection

LABELING: Each unit shall bear a permanent label with the manufacturer's name or logo, city, state and following statement: "Miami-Dade County Product Control Approved", unless otherwise noted herein.

RENEWAL of this NOA shall be considered after a renewal application has been filed and there has been no change in the applicable building code negatively affecting the performance of this product.

TERMINATION of this NOA will occur after the expiration date or if there has been a revision or change in the materials, use, and/or manufacture of the product or process. Misuse of this NOA as an endorsement of any product, for sales, advertising or any other purposes shall automatically terminate this NOA. Failure to comply with any section of this NOA shall be cause for termination and removal of NOA.

ADVERTISEMENT: The NOA number preceded by the words Miami-Dade County, Florida, and followed by the expiration date may be displayed in advertising literature. If any portion of the NOA is displayed, then it shall be done in its entirety.

INSPECTION: A copy of this entire NOA shall be provided to the user by the manufacturer or its distributors and shall be available for inspection at the job site at the request of the Building Official.

This NOA renews and revises NOA 16-1213.04 and consists of pages 1 through 10.
The submitted documentation was reviewed by Hamley Pacheco, P.E.



NOA No.: 18-0119.15
Expiration Date: 02/22/23
Approval Date: 02/22/18
Page 1 of 10

ROOFING COMPONENT APPROVAL

Category: Roofing
Sub-Category: Underlayment
Material: SBS/Polypropylene/Asphalt

PRODUCTS DESCRIPTION:

<u>Product</u>	<u>Dimensions</u>	<u>Test Specification</u>	<u>Product Description</u>
WeatherWatch® Mineral Surfaced Leak Barrier <i>Manufacturing Location #1, 9</i>	36" x 50' rolls 36" x 66.7' rolls	ASTM D 1970	Granular surfaced modified, fiberglass reinforced, bituminous sheet material for use as a leak barrier underlayment in sloped roof assemblies. Designed as an ice & rain shield.
StormGuard® Film Surfaced Leak Barrier <i>Manufacturing Location #1, 9</i>	36" x 66.7' rolls	ASTM D 1970	Modified, fiberglass reinforced, bituminous sheet material for use as a high temperature leak barrier underlayment in sloped roof assemblies. Designed as an ice & rain shield.
Liberty™ SBS Self-Adhering Base/Ply Sheet <i>Manufacturing Location #1, 9</i>	39- ³ / ₈ " x 66' rolls	ASTM D 1970 ASTM D4601 Type II	Self-adhering SBS roof membrane.
Deck-Armor™ Premium Breathable Roof Deck Protection <i>Manufacturing Location #2</i>	54" x 222' rolls 48" x 100' rolls	ASTM D 226 Type II	A UV-stabilized polypropylene breathable underlayment. To be used for roof deck protection as an underlayment in sloped roof assemblies.
Tiger Paw™ Roof Deck Protection <i>Manufacturing Location #3, 5, 6</i>	48" x 250' rolls 48" x 100' rolls	ASTM D 226 Type II	A UV-stabilized polypropylene non-breathable underlayment. To be used for roof deck protection as an underlayment in sloped roof assemblies.
FeltBuster® High-Traction Synthetic Roofing Felt <i>Manufacturing Location #7, 8</i>	48" x 250' rolls	ASTM D 226 Type I	A UV-stabilized polypropylene non-breathable underlayment. To be used for roof deck protection as an underlayment in sloped roof assemblies.
Shingle-Mate® Roof Deck Protection <i>Manufacturing Location #4</i>	36" x 144' rolls	ASTM D 226 Type I	Fiberglass-reinforced asphalt felt underlayment. To be used for roof deck protection as an underlayment in sloped roof assemblies.



PRODUCTS DESCRIPTION:

<u>Product</u>	<u>Dimensions</u>	<u>Test Specification</u>	<u>Product Description</u>
Liberty™ SA Glass Cap Sheet <i>Manufacturing Location # 9</i>	39-3/8" x 34' rolls	ASTM D 1970 ASTM D 6163 ASTM D 7530	Granular surfaced modified, fiberglass reinforced, self-adhering SBS roof membrane.
GAFGLAS® Ply 4 <i>Manufacturing Location # 9, 10</i>	39.37" (1 meter) Wide	ASTM D2178 Type IV	Asphalt impregnated glass felt with asphalt coating.
GAFGLAS® FlexPly™ 6 <i>Manufacturing Location # 9, 10</i>	39.37" (1 meter) Wide	ASTM D2178 Type VI	Asphalt impregnated glass felt with asphalt coating.

MANUFACTURING LOCATION:

- 1.Mt. Vernon, IN
- 2.North Bay, Ontario
- 3.Mission, British Columbia
- 4.Pryor, OK
- 5.Qingdao, China
- 6.Charleston, SC
- 7.Spartanburg, SC
- 8.Dadra, India
- 9.Savannah, GA
- 10.Mobile, AL



EVIDENCE SUBMITTED:

<u>Test Agency</u>	<u>Test Identifier</u>	<u>Test Name/Report</u>	<u>Date</u>
Intertek Testing Services NA Ltd.	3077464-01	ASTM D 1970	08/23/06
	3090131	Wind Uplift and Self Sealability	08/23/06
	100258583COQ-010A	ASTM D 226 Type II	01/08/11
	100673818COQ-003	ASTM D 226 Type II	06/13/13
	101572890COQ-005	ASTM D 226 Type II	04/17/14
	F8549.02-106-18	ASTM D 226 Type I	11/08/16
PRI Construction Materials Technologies, LLC.	RGM-023-02-01	ASTM D 4798	05/16/07
	GAF-112-02-01	ASTM D 226 Type II	03/15/06
	GAF-238-02-01	ASTM D 1970	03/03/10
	GAF-323-02-01	ASTM D 1970	11/30/11
	GAF-324-02-01	ASTM D 1970	12/01/11
	GAF-325-02-01	ASTM D 1970	12/01/11
	GAF-326-02-01	ASTM D 1970	11/30/11
	GAF-275-02-01	ASTM D 1970	11/11/10
	GAF-344-02-01	ASTM D 1970	04/23/12
	GAF-339-02-01	ASTM D 226 Type I	03/14/12
	ELK-311-02-01	ASTM D 1970	09/11/07
	GAF-518-02-01	ASTM D 226 Type I	06/04/14
	GAF-818-02-01	ASTM D 4533	12/06/17
	GAF-829-02-01	ASTM D 226 Type II	01/15/18
	GAF-314-02-01	ASTM D 2178	07/21/11
	GAF-315-02-01	ASTM D 2178	07/21/11
Trinity-ERD	GAF-SC13285.03.17-1	ASTM D 1970	03/08/17
	GAF-SC13285.03.17-3	ASTM D 1970	03/01/17
	GAF-SC13285.03.17-4	ASTM D 1970	03/01/17
	GAF-SC13285.02.17-2	ASTM D 4601 Type II	02/08/17
	GAF-SC9700.08-15-R1	ASTM D 2178	09/09/15
	GAF-SC12915.12.17-R1	ASTM D 1970	12/11/17
	GAF-SC12915.12.17-R1	ASTM D 6163	12/11/17
	GAF-SC12915.12.17-R1	ASTM D 7530	12/11/17



APPROVED ASSEMBLIES:

Deck Type 1: Wood, non-insulated

Deck Description: 1⁹/₃₂" or greater plywood or wood plank

System E (1): Anchor sheet mechanically fastened to deck, membrane adhered.

Base Sheet: Two plies of ASTM D 226 Type I or Shingle-Mate[®] Roof Deck Protection OR one or more plies of ASTM D 226 Type II, Deck-Armor[™] Premium Breathable Roof Deck Protection, FeltBuster[®] High-Traction Synthetic Roofing Felt, or Tiger Paw[™] Roof Deck Protection with a minimum 4" side lap and a 6" end lap mechanically fastened to the deck with approved nails and tin caps 6" o.c. at the laps and four staggered rows 12" o.c. in the field of the roll.

If roof is exposed to rain/snow, tape all end and side laps with approved butyl adhesive based seam/cover tape or an approved waterproof cloth duct tape (follow the tape's manufacturer's installation instructions). Always apply tape over all fasteners at the center of the roll or the end laps to help prevent rain or snow from entering at the fasteners.

Membrane: One or more plies of WeatherWatch[®] Mineral Surfaced Leak Barrier, StormGuard[®] Film Surfaced Leak Barrier, Liberty[™] SA Glass Cap Sheet, or Liberty[™] SBS Self-Adhering Base/Ply Sheet membrane with a minimum 3" side lap and 6" end lap. Place the first course of membrane parallel to the eave, rolling the membrane to obtain maximum contact. Remove the release membrane as the membrane is applied. Vertical strapping of the roof with WeatherWatch[®] Mineral Surfaced Leak Barrier, or StormGuard[®] Film Surfaced Leak Barrier is acceptable.

Surfacing: Approved Roofing Assembly.



- Deck Type 1:** Wood, non-insulated
- Deck Description:** ¹⁹/₃₂" or greater plywood or wood plank
- System E(2):** Membrane mechanically fastened to deck.
- Separator Sheet:** One or more plies of GAFGLAS® Ply 4, GAFGLAS® FlexPly™ 6, Shingle-Mate® Roof Deck Protection, Deck-Armor™ Premium Breathable Roof Deck Protection, FeltBuster® High-Traction Synthetic Roofing Felt, or Tiger Paw™ Roof Deck Protection loose laid.
- Membrane:** One or more plies of WeatherWatch® Mineral Surfaced Leak Barrier, StormGuard® Film Surfaced Leak Barrier, Liberty™ SA Glass Cap Sheet, or Liberty™ SBS Self-Adhering Base/Ply Sheet membrane mechanically fastened with a minimum 3" side lap and a 6" end lap to deck through the separator sheet with approved nails and tin caps 6" o.c. at the laps and two staggered rows 12" o.c. in the field of the roll.
- Surfacing:** Approved Roofing Assembly.



Deck Type 1: Wood, non-insulated

Deck Description: ¹⁹/₃₂" or greater plywood or wood plank

System E (3): Anchor sheet mechanically fastened to deck, membrane adhered.

Secondary Water Barrier: (Optional) Install a minimum 4" wide WeatherWatch® Mineral Surfaced Leak Barrier, , Liberty™ SBS Self-Adhering Base/Ply Sheet, Liberty™ SA Glass Cap Sheet, or StormGuard® Film Surfaced Leak Barrier membrane over the joints of the plywood roof deck prior to installation of the base sheet. Do not overlap end or side joints. All side and end laps should be butted firmly side by side, flush with each other but not overlapped. Do not leave the WeatherWatch® Mineral Surfaced Leak Barrier, or StormGuard® Film Surfaced Leak Barrier membrane exposed for more than 30 days without a roof deck protection underlayment protecting the secondary water barrier.

Base Sheet: Two plies of ASTM D 226 Type I or Shingle-Mate® Roof Deck Protection OR one or more plies of ASTM D 226 Type II, Deck-Armor™ Premium Breathable Roof Deck Protection, FeltBuster® High-Traction Synthetic Roofing Felt, or Tiger Paw™ Roof Deck Protection with a minimum 4" side lap and a 6" end lap mechanically fastened to the deck with approved nails and tin caps 6" o.c. at the laps and four staggered rows 12" o.c. in the field of the roll.

If roof is exposed to rain/snow, tape all end and side laps with approved butyl adhesive based seam/cover tape or an approved waterproof cloth duct tape (follow the tape manufacturer's installation instructions). Always apply tape over all fasteners at the center of the roll or the end laps to help prevent rain or snow from entering at the fasteners.

Surfacing: Approved Roofing Assembly.



- Deck Type 1:** Wood, non-insulated
- Deck Description:** ¹⁹/₃₂" or greater plywood or wood plank
- System E (4):** Anchor sheet mechanically fastened to deck, membrane adhered.
- Base Sheet:** Two plies of ASTM D 226 Type I or Shingle-Mate® Roof Deck Protection OR one or more plies of ASTM D 226 Type II, Deck-Armor™ Premium Breathable Roof Deck Protection, FeltBuster® High-Traction Synthetic Roofing Felt, or Tiger Paw™ Roof Deck Protection with a minimum 4" side lap and a 6" end lap mechanically fastened to the deck with approved nails and tin caps 6" o.c. at the laps and four staggered rows 12" o.c. in the field of the roll.
- If roof is exposed to rain/snow, tape all end and side laps with approved butyl adhesive based seam/cover tape or an approved waterproof cloth duct tape (follow the tape's manufacturer's installation instructions). Always apply tape over all fasteners at the center of the roll or the end laps to help prevent rain or snow from entering at the fasteners.
- Membrane:** One or more plies of StormGuard® Film Surfaced Leak Barrier membrane with a minimum 4" side lap and 6" end lap. Place the first course of membrane parallel to the eave, rolling the membrane to obtain maximum contact. Remove the release membrane as the membrane is applied.
- Surfacing:** Approved for Metal roofing, Slate, and Asphalt Shingle assemblies.



LIMITATIONS:

1. Fire classification is not part of this acceptance.
2. WeatherWatch® Mineral Surfaced Leak Barrier, StormGuard® Film Surfaced Leak Barrier, Liberty™ SBS Self-Adhering Base/Ply Sheet, Liberty™ SA Glass Cap Sheet, Shingle-Mate® Roof Deck Protection, Deck-Armor™ Premium Breathable Roof Deck Protection, FeltBuster® High-Traction Synthetic Roofing Felt, and Tiger Paw™ Roof Deck Protection shall not be used as roof tile underlayment.
3. This acceptance is for prepared roofing applications. Minimum deck requirements shall be in compliance with applicable building code. WeatherWatch® Mineral Surfaced Leak Barrier, StormGuard® Film Surfaced Leak Barrier, Liberty™ SBS Self-Adhering Base/Ply Sheet, Liberty™ SA Glass Cap Sheet, Shingle-Mate® Roof Deck Protection, Deck-Armor™ Premium Breathable Roof Deck Protection, FeltBuster® High-Traction Synthetic Roofing Felt, and Tiger Paw™ Roof Deck Protection shall be installed in strict compliance with applicable Building Code.
4. WeatherWatch® Mineral Surfaced Leak Barrier, StormGuard® Film Surfaced Leak Barrier, Liberty™ SBS Self-Adhering Base/Ply Sheet, Liberty™ SA Glass Cap Sheet, Shingle-Mate® Roof Deck Protection, Deck-Armor™ Premium Breathable Roof Deck Protection, FeltBuster® High-Traction Synthetic Roofing Felt, and Tiger Paw™ Roof Deck Protection membranes shall be applied to a smooth, clean and dry surface with deck free of irregularities.
5. WeatherWatch® Mineral Surfaced Leak Barrier, StormGuard® Film Surfaced Leak Barrier, Liberty™ SBS Self-Adhering Base/Ply Sheet, Liberty™ SA Glass Cap Sheet, Shingle-Mate® Roof Deck Protection, Deck-Armor™ Premium Breathable Roof Deck Protection, FeltBuster® High-Traction Synthetic Roofing Felt, and Tiger Paw™ Roof Deck Protection membranes shall not be applied over an existing roof membrane.
6. WeatherWatch® Mineral Surfaced Leak Barrier, StormGuard® Film Surfaced Leak Barrier, Liberty™ SBS Self-Adhering Base/Ply Sheet, Liberty™ SA Glass Cap Sheet, Shingle-Mate® Roof Deck Protection, Deck-Armor™ Premium Breathable Roof Deck Protection, FeltBuster® High-Traction Synthetic Roofing Felt, and Tiger Paw™ Roof Deck Protection shall not be left exposed as a temporary roof for longer than 30 days of application.
7. WeatherWatch® Mineral Surfaced Leak Barrier, StormGuard® Film Surfaced Leak Barrier, Liberty™ SBS Self-Adhering Base/Ply Sheet, Liberty™ SA Glass Cap Sheet, Shingle-Mate® Roof Deck Protection, Deck-Armor™ Premium Breathable Roof Deck Protection, FeltBuster® High-Traction Synthetic Roofing Felt, and Tiger Paw™ Roof Deck Protection may be used with any approved roof covering Notice of Acceptance listing WeatherWatch® Mineral Surfaced Leak Barrier, StormGuard® Film Surfaced Leak Barrier, Liberty™ SBS Self-Adhering Base/Ply Sheet, Liberty™ SA Glass Cap Sheet, Shingle-Mate® Roof Deck Protection, Deck-Armor™ Premium Breathable Roof Deck Protection, FeltBuster® High-Traction Synthetic Roofing Felt, and Tiger Paw™ Roof Deck Protection as a component part of an assembly in the Notice of Acceptance. If WeatherWatch® Mineral Surfaced Leak Barrier, StormGuard® Film Surfaced Leak Barrier, Liberty™ SBS Self-Adhering Base/Ply Sheet, Liberty™ SA Glass Cap Sheet, Shingle-Mate® Roof Deck Protection, Deck-Armor™ Premium Breathable Roof Deck Protection, FeltBuster® High-Traction Synthetic Roofing Felt and Tiger Paw™ Roof Deck Protection are not listed; a request may be made to the Authority Having Jurisdiction (AHJ) or the Miami-Dade County Product Control Department for approval provided that appropriate documentation is provided to detail compatibility of the products, wind uplift resistance, and fire testing results.
8. All nails in the deck shall be carefully checked for protruding heads. Re-fasten any loose decking panels. Sweep the deck thoroughly to remove any dust and debris prior to application. Install when temperatures are 45° F and rising.
9. When applying the membrane in the valley, start at the low point and work to the high point, rolling the membrane from the center outward in both directions.



LIMITATIONS:

10. Roll or broom the entire membrane surface so as to have 100% contact with the surface, giving special attention to overlap areas.
11. Flash vent pipes, stacks, chimneys and penetrations in compliance with Roof Assembly current Product Control Notice of Acceptance and applicable Building Code.
12. All products listed herein shall have a quality assurance audit in accordance with the Florida Building Code and Rule 61G20-3 of the Florida Administrative Code.
13. All membranes or packaging shall bear the imprint or identifiable marking of the manufacturer's name or logo, city and state of manufacturing facility, and the following statement: "Miami-Dade County Product Control Approved" or the Miami-Dade County Product Control Seal as shown below.



END OF THIS ACCEPTANCE



NOA No.: 18-0119.15
Expiration Date: 02/22/23
Approval Date: 02/22/18
Page 10 of 10

RICK SINGH, CFA - ORANGE COUNTY PROPERTY APPRAISER

- Searches
- Sales Search
- Results
- Property Record Card
- My Favorites

Sign up for e-Notify...

4221 Bell Tower Ct < 20-23-30-1618-00-510 >

Name(s) Lall Hemchander
 Physical Street Address 4221 Bell Tower Ct
 Mailing Address On File 12438 Greco Dr
 Orlando, FL 32824-5820
[Incorrect Mailing Address?](#)
 Postal City and Zipcode Orlando, FL 32812
 Property Use 0103 - Single Fam Class III
 Municipality Belle Isle



View 2018 Property Record Card

- Property Features
- Values, Exemptions and Taxes
- Sales Analysis
- Location Info
- Market Stats
- Update Information

Historical Value and Tax Benefits

Tax Year Values	Land	Building(s)	Feature(s)	Market Value	Assessed Value
2018 MKT	\$70,000 +	\$268,085 +	\$28,000 =	\$366,085 (4.1%)	\$294,261 (2.1%)
2017 MKT	\$62,000 +	\$261,049 +	\$28,500 =	\$351,549 (2.7%)	\$288,209 (2.1%)
2016 MKT	\$55,000 +	\$258,165 +	\$29,000 =	\$342,165 (2.5%)	\$282,281 (7.0%)
2015 MKT	\$55,000 +	\$249,452 +	\$29,500 =	\$333,952	\$280,319

Tax Year Benefits	Original Homestead	Additional Hx	Other Exemptions	SOH Cap	Tax Savings
2018 \$ HX CAP	\$25,000	\$25,000	\$0	\$71,824	\$1,910
2017 \$ HX CAP	\$25,000	\$25,000	\$0	\$63,340	\$1,781
2016 \$ HX CAP	\$25,000	\$25,000	\$0	\$59,884	\$1,752
2015 \$ HX CAP	\$25,000	\$25,000	\$0	\$53,633	\$1,675

2018 Tax Breakdown

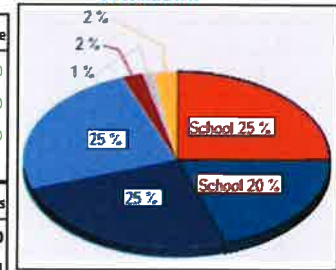

2018 Taxable Value and Certified Taxes

TAX YEAR | 2018 • 2017 • 2016 • 2015

Taxing Authority	Assd Value	Exemption	Tax Value	Millage Rate	Taxes %
Public Schools: By State Law (Rle)	\$294,261	\$25,000	\$269,261	4.0510 (-4.05%)	\$1,090.78 25 %
Public Schools: By Local Board	\$294,261	\$25,000	\$269,261	3.2480 (0.00%)	\$874.56 20 %
Orange County (General)	\$294,261	\$50,000	\$244,261	4.4347 (0.00%)	\$1,083.22 25 %
City Of Belle Isle	\$294,261	\$50,000	\$244,261	4.4018 (0.00%)	\$1,075.19 25 %
Library - Operating Budget	\$294,261	\$50,000	\$244,261	0.3748 (0.00%)	\$91.55 2 %
St Johns Water Management District	\$294,261	\$50,000	\$244,261	0.2562 (-5.95%)	\$62.58 1 %
Lake Conway Mstu	\$294,261	\$50,000	\$244,261	0.4107 (0.00%)	\$100.32 2 %
			17.1772		\$4,378.20

2018 Non-Ad Valorem Assessments

Levying Authority	Assessment Description	Units	Rate	Assessment
CITY OF BELLE ISLE	BELLE ISLE RES - GARBAGE - (407)851-7730	1.00	\$236.00	\$236.00
CITY OF BELLE ISLE	BELLE ISLE STRM - DRAINAGE - (407)851-7730	1.00	\$110.00	\$110.00
				\$346.00

2018 Gross Tax Total: \$4,724.20

2018 Tax Savings Tax Savings

Your property taxes without exemptions would be: \$6,288.32
 Your ad-valorem property tax with exemptions is: - \$4,378.20
Providing You A Savings Of: = \$1,910.12

This Data Printed on 07/26/2019 and System Data Last Refreshed on 07/25/2019



RICK SINGH, CFA - ORANGE COUNTY PROPERTY APPRAISER

[Searches](#)

[Sales Search](#)

[Results](#)

[Property Record Card](#)

[My Favorites](#)

[Sign up for e-Notify...](#)

4221 Bell Tower Ct < 20-23-30-1618-00-510 >

Name(s)

Lall Hemchander

Physical Street Address

4221 Bell Tower Ct

Mailing Address On File

Postal City and Zipcode

12438 Greco Dr

Orlando, FL 32812

Orlando, FL 32824-5820

Property Use

[Incorrect Mailing Address?](#)

0103 - Single Farm Class III

Municipality

Belle Isle



View 2018 Property Record Card

[Property Features](#)

[Values, Exemptions and Taxes](#)

[Sales Analysis](#)

[Location Info](#)

[Market Stats](#)



[Update Information](#)

Parcel Sales History

Sale Date	Sale Amount	Instrument #	Book/Page	Seller(s)	Buyer(s)	Deed Code	Vac/Imp
06/25/2019	\$112,400	20190396560	/	Hadley Jeffrey C	Lall Hemchander	Certificate of Title	Improved
02/23/2001	\$264,400	20010086629	06203 / 2039	Centex Real Estate Corp	Hadley Jeffrey C Hadley Elizabeth A	Warranty Deed	Improved

Sales In Subdivision Within Last 1 Year

[Sales Report](#) [Sales Analysis Tool](#)

Address	Sale Date	Sale Amount	\$/SQFT	Deed Code	Beds/Baths	Instrument #	Book/Page
 4221 Bell Tower Ct	06/25/2019	\$112,400	\$37	Certificate of Title	4/4	20190396560	/
 4155 Bell Tower Ct	12/18/2018	\$410,000	\$142	Warranty Deed	4/3	20180752468	/
6536 Franconia Dr	08/01/2018	\$135,000	\$39	Quitclaim Deed	4/4	20180486182	/

IN THE CIRCUIT COURT OF THE
NINTH JUDICIAL CIRCUIT IN AND
FOR ORANGE COUNTY, FLORIDA

CASE NO: 2018-CA-004268-O

**WELLS FARGO BANK, N.A. SUCCESSOR BY MERGER TO WACHOVIA BANK,
NATIONAL ASSOCIATION**

Plaintiff

Vs.

**JEFFREY C HADLEY A/K/A JEFFREY HADLEY A/K/A JEFFERY HADLEY A/K/A
JEFFERY C. HADLEY; KIRSTEN ANN SUMMER; CHRISTOPHER JOHN ROMEO;
JESSICA MARIE ROMEO; JON WAYNE STEIL, INDIVIDUALLY AND AS
PERSONAL REPRESENTATIVE OF THE ESTATE OF ELIZABETH A. HADLEY
A/K/A ELIZABETH HADLEY; UNKNOWN SPOUSE OF ELIZABETH A HADLEY
A/K/A ELIZABETH HADLEY; UNKNOWN TENANT 1; UNKNOWN TENANT 2;
ELIZABETH A HADLEY A/K/A ELIZABETH HADLEY;**

Defendant

CERTIFICATE OF TITLE

The undersigned, clerk of the court certifies that he or she executed and filed a certificate of sale in this action on 06/14/2019, for the property described herein and that no objections to the sale have been filed within the time allowed for filing objections.

Sale Price: \$112,400.00

The following property in Orange County, Florida:

**ALL THAT CERTAIN PROPERTY SITUATED IN THE CITY OF ORLANDO, IN
THE COUNTY OF ORANGE AND STATE OF FLORIDA AND BEING
DESCRIBED IN A DEED DATED 02/23/2001 AND RECORDED 02/28/2001 IN
BOOK 6203 PAGE 2039 AMONG THE LAND RECORDS OF THE COUNTY AND
STATE SET FORTH ABOVE AND REFERENCED AS FOLLOWS: LOT 51,
SUBDIVISION CONWAY GROVES UNIT 1, PLAT BOOK 36, PLAT PAGE 3.
PARCEL ID NUMBER: 202330161800510.**

Was sold to: **HEMCHANDER LALL**
12438 GRECO DR
ORLANDO, FL 32824

WITNESS my hand and the seal of the court on 6/25/2019.

DOC# 20190396560
06/27/2019 01:07:02 PM Page 1 of 1
Rec Fee: \$0.00
Deed Doc Tax: \$786.80
DOR Admin Fee: \$0.00
Intangible Tax: \$0.00
Mortgage Stamp: \$0.00
Phil Diamond, Comptroller
Orange County, FL
IO - Ret To: CLERK OF COURT CIVIL



Tiffany Moore Russell
Clerk of the Circuit Court

/s Stephanie Rawls
By: 2019.06.25 08:48:55 -04'00'
Deputy Clerk

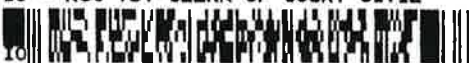



Ron DeSantis, Governor

Halsey Beshears, Secretary



STATE OF FLORIDA

DEPARTMENT OF BUSINESS AND PROFESSIONAL REGULATION

CONSTRUCTION INDUSTRY LICENSING BOARD

THE ROOFING CONTRACTOR HEREIN IS CERTIFIED UNDER THE PROVISIONS OF CHAPTER 489, FLORIDA STATUTES

HECTOR YORDANYS
ONE WORLD ROOFING LLC
390 NORTH ORANGE AVENUE SUITE 2300
ORLANDO FL 32825

LICENSE NUMBER: CCC1330134

EXPIRATION DATE: AUGUST 31, 2020

Always verify licenses online at MyFloridaLicense.com

Do not alter this document in any form.

This is your license. It is unlawful for anyone other than the licensee to use this document.



Tax Collector Scott Randolph**Local Business Tax Receipt****Orange County, Florida**

This local Business Tax Receipt is in addition to and not in lieu of any other tax required by law or municipal ordinance. Businesses are subject to regulation of zoning, health and other lawful authorities. This receipt is valid from October 1 through September 30 of receipt year. **Delinquent penalty is added October 1.**

	2018	EXPIRES	9/30/2019			5000-1207619
5000 BUSINESS QFFICE	\$15.00	1 EMPLOYEE	1806	CERT ROOFING CONTR	\$15.00	1 EMPLOYEE



TOTAL TAX	\$30.00
PREVIOUSLY PAID	\$30.00
TOTAL DUE	\$0.00

HECTOR YORDANYS QUALIFIER-CCC1330134

2156 SUNSET TERRACE DR (MOBILE)
U - ORLANDO, 32825

CCC1330134

PAID: \$30.00 2504-04979367 4/12/2019

ONE WORLD ROOFING LLC
HECTOR YORDANYS
390 N ORANGE AVE SUITE 2300
ORLANDO FL 32801

This receipt is official when validated by the Tax Collector.



JIMMY PATRONIS
CHIEF FINANCIAL OFFICER

**STATE OF FLORIDA
DEPARTMENT OF FINANCIAL SERVICES
DIVISION OF WORKERS' COMPENSATION**

**** CERTIFICATE OF ELECTION TO BE EXEMPT FROM FLORIDA WORKERS' COMPENSATION LAW ****

CONSTRUCTION INDUSTRY EXEMPTION

This certifies that the individual listed below has elected to be exempt from Florida Workers' Compensation law.

EFFECTIVE DATE: 5/3/2019

EXPIRATION DATE: 5/2/2021

PERSON: YORDANYS HECTOR

EMAIL: OWROOFING@ICLOUD.COM

FEIN: 611896721

BUSINESS NAME AND ADDRESS:

ONE WORLD ROOFING LLC

390 N. ORANGE AVE SUITE 2300

ORLANDO, FL 32801

SCOPE OF BUSINESS OR TRADE:

Asbestos Removal

Insulation Work NOC and

Roofing - All Kinds and

Carpentry Dwellings

Operations: Contractor-NOC
and Drivers

Drivers

Drivers

Three Stories or Less

IMPORTANT: Pursuant to Chapter 440.05(14), F.S., an officer of a corporation who elects exemption from this chapter by filing a certificate of election under this section may not recover benefits or compensation under this chapter. Pursuant to Chapter 440.05(12), F.S., Certificates of election to be exempt... apply only within the scope of the business or trade listed on the notice of election to be exempt. Pursuant to Chapter 440.05(13), F.S., Notices of election to be exempt and certificates of election to be exempt shall be subject to revocation if, at any time after the filing of the notice or the issuance of the certificate, the person named on the notice or certificate no longer meets the requirements of this section for issuance of a certificate. The department shall revoke a certificate at any time for failure of the person named on the certificate to meet the requirements of this section.

