



City of Belle Isle Job Site Card **Roof PERMIT 2018-08-056**

PERMIT MUST BE POSTED ON SITE - A permit expires in 6 months if approved inspections are not recorded /scheduled within that time frame. You are responsible for scheduling and keeping track of all your inspections -

Permit Number 2018-08-056

Issue Date 8/22/2018

Site Address: 6619 Orange Knoll Dr 32812

Parcel Number: 20-23-30-1678-00-580

Class: Residential

Subdivision:

Description of Work: Re-roof **3800 SQFT - Asphalt Shingles**

Issued To: JA Edwards of America

Business Phone: 407 677-7663

Name: Gerald Lanschober

Contractor License: CCC057521

Payment Date & Method: **8 / 22 / 2018** Picked up by _____

Visa Master Card Amex Discover Check / Money Order # **0787**

Schedule Inspections via Email at: BIDScheduling@universalengineering.com

SCHEDULE INSPECTIONS BY 3:00 PM CUT OFF TIME

Inspection Results Will Be Sent Out the Following Business Day

"WARNING TO OWNER: YOUR FAILURE TO RECORD A NOTICE OF COMMENCEMENT MAY RESULT IN YOUR PAYING TWICE FOR IMPROVEMENTS TO YOUR PROPERTY. IF YOU INTEND TO OBTAIN FINANCING, CONSULT WITH YOUR LENDER OR AN ATTORNEY BEFORE RECORDING YOUR NOTICE OF COMMENCEMENT."

ROOF INSPECTOR DATE COMMENTS

NEW ROOFS ONLY Code 700 Deck Nailing, Dry-In, Flashing			
Both new & re-roof Code 710 In - Progress			
Both new & re-roof Code 720 Final			

Inspection requests are to be emailed to BIDScheduling@UniversalEngineering.com; a confirmation email will be sent back to you upon scheduling. **Next-Day Inspection requests must be made by 3:00pm.**

Please include the following in your request: Permit #, project address, type of inspection, date of the requested inspection, a contact name & a contact phone number. AM or PM may be requested but cannot be guaranteed.



RECEIVED
AUG 21 2018

City of Belle Isle
Universal Engineering Sciences 3532 Maggie Blvd., Orlando, FL 32811
Tel 407-581-8161 * Fax 407-581-0313 * www.universalerengineering.com

APPLICATION FOR ROOFING PERMIT

WARNING TO OWNER: YOUR FAILURE TO RECORD A NOTICE OF COMMENCEMENT MAY RESULT IN YOUR PAYING TWICE FOR IMPROVEMENTS TO YOUR PROPERTY. A NOTICE OF COMMENCEMENT MUST BE RECORDED AND POSTED ON THE JOB SITE BEFORE THE FIRST INSPECTION. IF YOU INTEND TO OBTAIN FINANCING, CONSULT WITH YOUR LENDER OR AN ATTORNEY BEFORE RECORDING YOUR NOTICE OF COMMENCEMENT.

DATE OF APPLICATION: 08-10-18 ROOF PERMIT NUMBER 2018-08-086

PLEASE PRINT. The undersigned hereby applies for a permit to make installations as indicated below:

Project Address 6619 Orange Knoll Dr, Belle Isle, FL 32809^X 32812
Property Owner Daniel Colpas Phone 347-268-1377
Property Owner's Mailing Address 529 Kingway Dr City Deltona
State FL Zip Code 32725 Parcel Id Number: 20-23-30-1678-00-580

REQUIRED! To obtain this information, please visit <http://www.ocpafil.org/Searches/ParcelSearch.aspx>

Class of Building: Old New Type of Building: Residential Commercial Other
Type of Work: New Roof ReRoof

• **REQUIRED! Florida Product Approval Form – NOTE: installation instructions must be posted on-site before your first inspection!!**

Please indicate the nature of work by completing the information below:

Roof Square Footage: 3800 Number of Stories: 1 Job Valuation: \$ 20,501.00
Type: Asphalt Shingles Metal Modified Bitumen Other: _____

I hereby certify that the above is true and correct to the best of my knowledge and make Application for Permit as outlined above, and if same is granted I agree to conform to all Florida Building Code Regulations and City Ordinances regulating same and in accordance with plans submitted. The issuance of this permit does not grant permission to violate any applicable Town and/or State of Florida codes and/or ordinances. By signing below, I recognize Republic Services is by legal contract the sole authorized provider of garbage, recycling, yard waste, and commercial garbage and construction debris collection and disposal services with the city limits of the City. Contractors, homeowners and commercial businesses may contact Republic Services at 407-293-8000 to setup accounts for Commercial, Construction Roll Off, or other services needed. Rates are fixed by contract and are available at City Hall or from Republic Services. The City enforces the contract through its code enforcement office. Failure to comply will result in a stop work order.

LICENSE HOLDER SIGNATURE [Signature] LICENSE # CCC057521
LICENSE HOLDER NAME Gerald Laschober COMPANY NAME JA Edwards of America, Inc.
Street Address 220 Weber St
City Orlando State FL Zip Code 32803 Phone Number 407-677-7663
Email Address pete@jaeofamerica.com

Building Official: SM Date 8-21-18
Verified Contractor's Licenses & Insurance are on file [Signature] Date 8-21-2018

Zoning Fee	\$	<u>30.00</u>
Building Fee	\$	<u>125.00</u>
Review Fee	\$	<u>—</u>
1% BCAIB Fee	\$	<u>2.00</u>
1.5% DCA Fee	\$	<u>2.00</u>
Total Permit Fee	\$	<u>159.00</u>

✓ POA
✓ NBC

NOTE: The Building Permit Number is required if the Roof Installation is associated with any construction or alteration where a Building Permit has been issued.

1ST IC 25
5426 100
125

PAID
8-22-2018
VISA 0787

Permit Number: _____
Folio/Parcel ID #: 20-23-30-1678-00-580
Prepared by: Peter Arcomone

2018-08-056

DOC# 20180480087
08/13/2018 01:45:16 PM Page 1 of 1
Rec Fee: \$10.00
Phil Diamond, Comptroller
Orange County, FL
IP - Ret To: JA EDWARDS OF AMERICA INC

Return to: JA Edwards of America, Inc.
220 Weber Street
Orlando, FL 32803



NOTICE OF COMMENCEMENT

State of Florida, County of Orange

The undersigned hereby gives notice that improvement will be made to certain real property, and in accordance with Chapter 713, Florida Statutes, the following information is provided in this Notice of Commencement.

- Description of property** (legal description of the property, and street address if available)
CONWAY LAKES 813 LOT 58 6619 ORANGE KNOLL DR
- General description of improvement**
KC ROOF ORLANDO FL 32812
- Owner information or Lessee information if the Lessee contracted for the improvement**
Name Daniel Colpas
Address 529 Kingway Dr Deltona FL 32725
Interest in Property owner
Name and address of fee simple titleholder (if different from Owner listed above)
Name _____
Address _____
- Contractor**
Name JA Edwards of America, Inc. Telephone Number 407.677.7663
Address 220 Weber Street Orlando, FL 32803
- Surety** (if applicable, a copy of the payment bond is attached)
Name _____ Telephone Number _____
Address _____ Amount of Bond \$ _____
- Lender**
Name _____ Telephone Number _____
Address _____
- Persons within the State of Florida designated by Owner upon whom notices or other documents may be served as provided by §713.13(1)(a)7, Florida Statutes.**
Name _____ Telephone Number _____
Address _____
- In addition to himself or herself, Owner designates the following to receive a copy of the Lienor's Notice as provided in §713.13(1)(b), Florida Statutes.**
Name _____ Telephone Number _____
Address _____
- Expiration date of notice of commencement** (the expiration date will be 1 year from the date of recording unless a different date is specified) _____

State of FLORIDA, County of ORANGE
I hereby certify that this is a true copy of the document as reflected in the Official Records
PHIL DIAMOND, COUNTY COMPTROLLER
D.C.
DATE: 08-13-18



WARNING TO OWNER: ANY PAYMENTS MADE BY THE OWNER AFTER THE EXPIRATION OF THE NOTICE OF COMMENCEMENT ARE CONSIDERED IMPROPER PAYMENTS UNDER CHAPTER 713, PART I, SECTION 713.13, FLORIDA STATUTES, AND CAN RESULT IN YOUR PAYING TWICE FOR IMPROVEMENTS TO YOUR PROPERTY. A NOTICE OF COMMENCEMENT MUST BE RECORDED AND POSTED ON THE JOB SITE BEFORE THE FIRST INSPECTION. IF YOU INTEND TO OBTAIN FINANCING, CONSULT WITH YOUR LENDER OR AN ATTORNEY BEFORE COMMENCING WORK OR RECORDING YOUR NOTICE OF COMMENCEMENT.

[Signature]
Signature of Owner or Lessee, or Owner's or Lessee's Authorized Officer/Director/Partner/Manager
Signatory's Title/Office _____

The foregoing instrument was acknowledged before me this 10 day of August by Daniel Colpas
as Owner for _____
Type of authority, e.g., officer, trustee, attorney in fact Name of party on behalf of whom instrument was executed

Signature of Notary Public - State of Florida Print, type, or stamp commissioned name of Notary Public

Personally Known _____ OR Produced ID
Type of ID Produced FLC



PETER JAMES ARCOMONE
MY COMMISSION # GG 035010
EXPIRES: October 2, 2020
Bonded Thru Budget Notary Services



CITY OF BELLE ISLE, FLORIDA
Universal Engineering Sciences 3532 Maggie Blvd., Orlando, FL 32811
Tel 407-581-8161 * Fax 407-581-0313 * www.universalengineering.com

POWER OF ATTORNEY

Date: 8-10-18

Permit #: 2018-08-056

I hereby name and appoint Peter Arcomone of
(print name)

JA Edwards of America, Inc. to be my lawful attorney-in-fact to act for
(company name)

me and apply to the City of Belle Isle Building Department for a Roofing permit
(type of permit)

for work to be performed at the following location:

6619 Orange Knoll Dr, Belle Isle, FL 32809 32812 and
(street address)

to sign my name and do all things necessary to this appointment.

Certified Contractor's Printed Name: Gerald Laschober

License Number: CCC057521

Certified Contractor's Signature: [Signature]

.....
The foregoing instrument was acknowledged before me this 10 days of Aug of 20 18
by Gerald Laschober who is personally known to me or who produced
as identification and who did not take an oath.

State of Florida
County of Orange

[Signature] RENEE CHRISTINE COLLINS
Notary Public, Orange County, Florida



RENEE C. COLLINS
Commission # GG 172994
Expires January 7, 2022
Bonded Thru Budget Notary Services

(seal)



City of Belle Isle

Universal Engineering Sciences 3532 Maggie Blvd., Orlando, FL 32811
 Tel 407-581-8161 * Fax 407-581-0313 * www.universalengineering.com

Product Approval Form

DATE: 08-10-18

PERMIT # 208-08-058

PROJECT ADDRESS 6619 Orange Knoll Dr, Belle Isle, FL 32809 X 32812

As required by Florida Statue 553.842 and Florida Administrative Code 9B-72m, please provide the information and approval numbers of the building components listed below if they will be utilized on the building or structure. FL Approved products are listed online at www.floridabuilding.org or can be obtained from the local product supplier. The following information must be turned in with permit application and available onsite for inspections:

• **NOTE: The Installation instructions must be posted on-site before your first inspection!!**

Product Type	Manufacturer	Model/Series	FL Product Approval #	Product Type	Manufacturer	Model/Series	FL Product Approval #
EXTERIOR DOORS				WALL PANELS			
Swinging				Sliding			
Sliding				Soffits			
Sectional/Rollup				Storefront			
Other				Glass Block			
				Other			
WINDOWS				ROOFING PRODUCTS			
Single/Dbl Hung				Asphalt Shingles	GAF	Timberline	FL10124-R20 ✓
Horizontal Slider				Non Struct Metal			
Casement				Roofing Tiles			
Fixed				Single Ply Roof			
Mullion				Underlayment	Interwrap	RhinoRoof	FL15216-R4 ✓
Skylights				Other			
Other							
STRUCTURAL COMPONENTS				OTHER			
Wood Connectors							
Wood Anchors							
Truss Plates							
Insulation Forms							
Lintels							
Other							

It is the applicant's responsibility to verify that specific products have been installed in accordance with their limitations and with the minimum required design pressures for the structure. Specific compliance will be verified during field inspections.

Applicant Signature 

Date 08-10-18

FLORIDA DEPARTMENT OF
Business & Professional Regulation



[DBPR HOME](#) | [ABOUT DBPR](#) | [DBPR DIVISIONS](#) | [CONTACT DBPR](#)

[BCIS Home](#) | [Log In](#) | [User Registration](#) | [Hot Topics](#) | [Submit Surcharge](#) | [Stats & Facts](#) | [Publications](#) | [Contact Us](#) | [BCIS Site Map](#) | [Links](#) | [Search](#)

**Product Approval**

USER: Public User

[Product Approval Menu](#) > [Product or Application Search](#) > [Application List](#) > **Application Detail**

OFFICE OF THE
SECRETARY

FL #	FL15216-R4	✓
Application Type	Revision	
Code Version	2017	
Application Status	Approved	
Comments	Archived	
Product Manufacturer	Owens Corning Roofing and Asphalt, LLC	
Address/Phone/Email	One Owens Corning Parkway Toledo, OH 43645 (740) 321-6345 Greg.Keeler@owenscorning.com	
Authorized Signature	Keeler Greg Greg.Keeler@owenscorning.com	
Technical Representative	Greg Keeler	
Address/Phone/Email	2790 Columbus Road Granville, OH 43023 (740) 321-6345 greg.keeler@owenscorning.com	
Quality Assurance Representative	Address/Phone/Email	
Category	Roofing	✓
Subcategory	Underlayments	
Compliance Method	Evaluation Report from a Florida Registered Architect or a Licensed Florida Professional Engineer Evaluation Report - Hardcopy Received	
Florida Engineer or Architect Name who developed the Evaluation Report	Robert Nieminen	
Florida License	PE-59166	
Quality Assurance Entity	Intertek Testing Services NA, Inc. - QA Entity	
Quality Assurance Contract Expiration Date	12/31/2020	
Validated By	John W. Knezevich, PE ✓ Validation Checklist - Hardcopy Received	
Certificate of Independence	FL15216_R4_COI_2018_01_COI_NIEMINEN.pdf	
Referenced Standard and Year (of Standard)	Standard	Year
	ASTM D1970 (tear)	2015
	ASTM D226 (physicals)	2009
	TAS 117(B)	1995
Equivalence of Product Standards Certified By		
Sections from the Code		

Product Approval Method	Method 1 Option D
Date Submitted	04/20/2018
Date Validated	04/20/2018
Date Pending FBC Approval	04/22/2018
Date Approved	06/12/2018

Summary of Products

FL #	Model, Number or Name	Description
15216.1	RhinoRoof Underlayments	Synthetic roof underlayments
Limits of Use Approved for use in HVHZ: No Approved for use outside HVHZ: Yes Impact Resistant: N/A Design Pressure: N/A Other: See ER Section 5 for Limits of Use.		Installation Instructions FL15216 R4 II 2018 04 FINAL ER OWENS CORNING RHINOROOFL15216-R4.pdf Verified By: Robert Nieminen PE-59166 Created by Independent Third Party: Yes Evaluation Reports FL15216 R4 AE 2018 04 FINAL ER OWENS CORNING RHINOROOFL15216-R4.pdf Created by Independent Third Party: Yes

[Back](#) [Next](#)

Contact Us :: [2601 Blair Stone Road, Tallahassee FL 32399 Phone: 850-487-1824](#)

The State of Florida is an AA/EEO employer. [Copyright 2007-2013 State of Florida](#) :: [Privacy Statement](#) :: [Accessibility Statement](#) :: [Refund Statement](#)

Under Florida law, email addresses are public records. If you do not want your e-mail address released in response to a public-records request, do not send electronic mail to this entity. Instead, contact the office by phone or by traditional mail. If you have any questions, please contact 850.487.1395. *Pursuant to Section 455.275(1), Florida Statutes, effective October 1, 2012, licensees licensed under Chapter 455, F.S. must provide the Department with an email address if they have one. The emails provided may be used for official communication with the licensee. However email addresses are public record. If you do not wish to supply a personal address, please provide the Department with an email address which can be made available to the public. To determine if you are a licensee under Chapter 455, F.S., please click [here](#).

Product Approval Accepts:



Credit Card
Safe





NEMO|etc.

Certificate of Authorization #32455
353 Christian Street, Unit #13
Oxford, CT 06478
(203) 262-9245

ENGINEER

EVALUATE

TEST

CONSULT

CERTIFY

EVALUATION REPORT

Owens Corning Roofing and Asphalt, LLC
One Owens Corning Parkway
Toledo, OH 43659
(740) 321-6345

Evaluation Report I40510.02.12-R4
FL15216-R4
Date of Issuance: 02/17/2012
Revision 4: 04/19/2018

SCOPE:

This Evaluation Report is issued under **Rule 61G20-3** and the applicable rules and regulations governing the use of construction materials in the State of Florida. The documentation submitted has been reviewed by Robert Nieminen, P.E. for use of the product under the Florida Building Code and Florida Building Code, Residential Volume. The products described herein have been evaluated for compliance with the **6th Edition (2017) Florida Building Code** sections noted herein.

DESCRIPTION: RhinoRoof Underlayments

LABELING: Labeling shall be in accordance with the requirements of the Accredited Quality Assurance Agency noted herein.

CONTINUED COMPLIANCE: This Evaluation Report is valid until such time as the named product(s) changes, the referenced Quality Assurance documentation changes, or provisions of the Code that relate to the product change. Acceptance of this Evaluation Report by the named client constitutes agreement to notify Robert Nieminen, P.E. of any changes to the product(s), the Quality Assurance or the production facility location(s). NEMO|etc. requires a complete review of this Evaluation Report relative to updated Code requirements with each Code Cycle.

ADVERTISEMENT: The Evaluation Report number preceded by the words "NEMO|etc. Evaluated" may be displayed in advertising literature. If any portion of the Evaluation Report is displayed, then it shall be done in its entirety.

INSPECTION: Upon request, a copy of this entire Evaluation Report shall be provided to the user by the manufacturer or its distributors and shall be available for inspection at the job site at the request of the Building Official.

This Evaluation Report consists of pages 1 through 3.

Prepared by:

Robert J.M. Nieminen, P.E.
Florida Registration No. 59166, Florida DCA ANE1983



The facsimile seal appearing was authorized by Robert Nieminen, P.E. on 04/19/2018. This does not serve as an electronically signed document.

CERTIFICATION OF INDEPENDENCE:

1. NEMO ETC, LLC does not have, nor does it intend to acquire or will it acquire, a financial interest in any company manufacturing or distributing products it evaluates.
2. NEMO ETC, LLC is not owned, operated or controlled by any company manufacturing or distributing products it evaluates.
3. Robert Nieminen, P.E. does not have nor will acquire, a financial interest in any company manufacturing or distributing products for which the evaluation reports are being issued.
4. Robert Nieminen, P.E. does not have, nor will acquire, a financial interest in any other entity involved in the approval process of the product.
5. This is a building code evaluation. Neither NEMO|etc. nor Robert Nieminen, P.E. are, in any way, the Designer of Record for any project on which this Evaluation Report, or previous versions thereof, is/was used for permitting or design guidance unless retained specifically for that purpose.

ROOFING COMPONENT EVALUATION:
1. SCOPE:
Product Category: Roofing

Sub-Category: Underlayment

Compliance Statement: **RhinoRoof Underlayments**, as produced by **Owens Corning Roofing and Asphalt, LLC**, has demonstrated compliance with the following sections of the **6th Edition (2017) Florida Building Code** through testing in accordance with applicable sections of the following Standards. Compliance is subject to the Installation Requirements and Limitations / Conditions of Use set forth herein.

2. STANDARDS:

<u>Section</u>	<u>Properties</u>	<u>Standard</u>	<u>Year</u>
1507.1.1, R905.1.1 Exception	Unrolling, Breaking Strength, Pliability	ASTM D226	2009
1507.1.1, R905.1.1 Exception	Tear Strength	ASTM D1970	2015
TAS 110	Pull-through resistance	TAS 117(B)	1995

3. REFERENCES:

<u>Entity</u>	<u>Examination</u>	<u>Reference</u>	<u>Date</u>
ITS (TST1509)	Physical Properties	100539395COQ-006	10/27/2011
ITS (TST1509)	Physical Properties	100539395COQ-002	10/27/2011
ITS (TST1509)	Physical Properties	100539395COQ-006	03/14/2014
PRI (TST5878)	ASTM D1970; Tear strength	OCF-330-02-02	10/03/2017
PRI (TST5878)	TAS 117(B); Pull-through	OCF-422-02-01	04/03/2018
ITS (QUA1673)	Quality Control	Service Confirmation	09/30/2017

4. PRODUCT DESCRIPTION:

4.1 **RhinoRoof U20** is a multilayered polymer woven coated synthetic roof underlayment available in 42-inch wide rolls, and can be produced in various other sizes; meets FBC 1507.1.1 & R905.1.1 (Exception).

5. LIMITATIONS:

5.1 This is a building code evaluation. Neither NEMO ETC, LLC nor Robert Nieminen, P.E. are, in any way, the Designer of Record for any project on which this Evaluation Report, or previous versions thereof, is/was used for permitting or design guidance unless retained specifically for that purpose.

5.2 This Evaluation Report is not for use in FBC HVHZ jurisdictions.

5.3 Fire Classification is not part of this Evaluation Report; refer to current Approved Roofing Materials Directory or test report from accredited testing agency for fire ratings of this product.

5.4 **RhinoRoof Underlayments** may be used with any prepared roof cover where the product is specifically referenced within FBC approval documents. If not listed, a request may be made to the Authority Having Jurisdiction for approval based on this evaluation combined with supporting data for the prepared roof covering.

5.5 Allowable Roof Covers:

TABLE 1: ROOF COVER OPTIONS						
Underlayment	Asphalt Shingles	Nail-On Tile	Foam-On Tile	Metal	Wood Shakes & Shingles	Slate or Simulated Slate
RhinoRoof U20	Yes	No	No	Yes	Yes	No

5.6 Exposure Limitations:

RhinoRoof U20 shall not be left exposed for longer than **30-days** after installation.

**6. INSTALLATION:**

6.1 **RhinoRoof Underlayments** shall be installed in accordance with **Owens Corning Roofing and Asphalt, LLC** published installation instructions subject to the Limitations set forth in Section 5 herein and the specifics noted below.

6.2 Re-fasten any loose decking panels, and check for protruding nail heads. Sweep the substrate thoroughly to remove any dust and debris prior to application.

6.3 RhinoRoof U20:

6.3.1 Shall be installed in compliance with the requirements for **ASTM D226, Type I or II** underlayment in **FBC Table 1507.1.1 or R905.1.1** for the type of prepared roof covering to be installed, taking into account the wider sheet-width.

6.3.2 Fasteners:

For exposure ≤ 24 hours, corrosion resistant fasteners may be 1-inch roofing nails with a 3/8-inch diameter head, minimum 1-inch diameter plastic or metal cap nails or FBC HVHZ nails & 1-5/8" diameter tin caps (with the rough edge facing up). The use of staples is prohibited.

For exposure > 24 hours up to maximum 30 days, corrosion resistant fasteners shall be minimum 1-inch diameter plastic or metal cap nails or FBC HVHZ nails & 1-5/8" diameter tin caps (with the rough edge facing up). The use of staples is prohibited.

6.3.2.1 Code Reference: The Exception statement in FBC 1507.1.1 and FBC R905.1.1 states: "...except metal cap nails shall be required where the ultimate design wind speed, V_{ult} , equals or exceeds 150 mph."

Owens Corning Roofing and Asphalt, LLC has furnished data to permit the use of 1-inch diameter plastic cap nails in lieu of metal cap nails for these applications, when the **RhinoRoof U20** underlayment is installed beneath mechanically fastened prepared roof covers referenced in FBC Table 1507.1.1 or R905.1.1.

6.3.3 Single Layer; Roof Slope $> 4:12$:

End (vertical) laps shall be minimum 6-inches and side (horizontal) laps shall be minimum 4-inches. Refer to Owens Corning Roofing and Asphalt, LLC recommendations for alternate lap configurations and/or the use of sealant under certain conditions.

For exposure ≤ 24 hours, use of every-other fastening location printed on the surface is acceptable. For exposure > 24 hours up to maximum 30-days, use of every fastening location printed on the surface is required.

When batten systems are to be installed atop the underlayment, the underlayment need only be preliminarily attached pending attachment of the battens on the same day. Battens shall not be positioned over cap nails. If this occurs, remove the cap nail and patch the hole in accordance with Owens Corning Roofing and Asphalt, LLC published instructions.

6.3.4 Double Layer; $2:12 < \text{Roof Slope} < 4:12$:

End (vertical) laps shall be minimum 12-inches and side (horizontal) laps shall be minimum half-sheet-width plus 1-inch.

Double layer application; begin by fastening a half-width plus 1-inch starter strip along the eaves. Place a full-width sheet over the starter, completely overlapping the starter course. Continue as noted in 6.3.3, but maintaining minimum half-width plus 1-inch side (horizontal) laps, resulting in a double-layer application.



NEMO | etc.

7. BUILDING PERMIT REQUIREMENTS:

As required by the Building Official or Authority Having Jurisdiction in order to properly evaluate the installation of this product.

8. MANUFACTURING PLANTS:

Qingdao, China

9. QUALITY ASSURANCE ENTITY:

Intertek Testing Services NA Inc. – QUA1673; (608) 836-4400

- END OF EVALUATION REPORT -

Akerman's 2018 ICSC Florida Conference Networking Reception

General Options

Name:

Jim Sargeant

Title:

Corporate Sales Rep

Company:

Universal Engineering Sciences

Address:

Florida

USA

Number of People Registered:

1

Confirmation Number:

P7N2H4ZJTRW (needed to modify your registration)

Event Title:

Akerman's 2018 ICSC Florida Conference Networking Reception

Location:

Hyatt Regency Orlando

9801 International Drive

Orlando, Florida

Date:

08/27/2018

Time:

5:30 PM

Current Registration Details

Product Approval
 USER: Public User

[Product Approval Menu](#) > [Product or Application Search](#) > [Application List](#) > **Application Detail**

 OFFICE OF THE
 SECRETARY

FL #	FL10124-R20 ✓												
Application Type	Revision												
Code Version	2017												
Application Status	Approved												
Comments	Archived												
Product Manufacturer	GAF												
Address/Phone/Email	1 Campus Drive Parispany, NJ 07054 (800) 766-3411 mstieh@gaf.com												
Authorized Signature	Robert Nieminen lindareith@trinityerd.com												
Technical Representative	William Broussard												
Address/Phone/Email	1 Campus Drive Parsippany, NJ 07054 (800) 766-3411 TechnicalQuestionsGAF@gaf.com												
Quality Assurance Representative													
Address/Phone/Email													
Category	Roofing ✓												
Subcategory	Asphalt Shingles ✓												
Compliance Method	Evaluation Report from a Florida Registered Architect or a Licensed Florida Professional Engineer Evaluation Report - Hardcopy Received												
Florida Engineer or Architect Name who developed the Evaluation Report	Robert Nieminen												
Florida License	PE-59166												
Quality Assurance Entity	UL LLC												
Quality Assurance Contract Expiration Date	10/20/2018												
Validated By	John W. Knezevich, PE ✓ Validation Checklist - Hardcopy Received												
Certificate of Independence	FL10124_R20_COI_2017_01_COI_Nieminen.pdf												
Referenced Standard and Year (of Standard)	<table> <thead> <tr> <th>Standard</th> <th>Year</th> </tr> </thead> <tbody> <tr> <td>ASTM D1970</td> <td>2015</td> </tr> <tr> <td>ASTM D3161</td> <td>2016</td> </tr> <tr> <td>ASTM D3462</td> <td>2010</td> </tr> <tr> <td>ASTM D7158</td> <td>2011</td> </tr> <tr> <td>TAS 107</td> <td>1995</td> </tr> </tbody> </table>	Standard	Year	ASTM D1970	2015	ASTM D3161	2016	ASTM D3462	2010	ASTM D7158	2011	TAS 107	1995
Standard	Year												
ASTM D1970	2015												
ASTM D3161	2016												
ASTM D3462	2010												
ASTM D7158	2011												
TAS 107	1995												
Equivalence of Product Standards Certified By													

Sections from the Code

Product Approval Method Method 1 Option D

Date Submitted 09/20/2017
 Date Validated 09/27/2017
 Date Pending FBC Approval 09/28/2017
 Date Approved 12/12/2017

Summary of Products

FL #	Model, Number or Name	Description
10124.1	GAF Asphalt Roof Shingles	Fiberglass reinforced 3-tab, laminated, 5-tab and hip/ridge asphalt shingles
Limits of Use Approved for use in HVHZ: No Approved for use outside HVHZ: Yes Impact Resistant: N/A Design Pressure: N/A Other: Refer to ER, Section 5.		Installation Instructions FL10124 R20 II 2017 09 FINAL ER GAF Asphalt Shingles FL10124-R20.pdf Verified By: Robert Nieminen PE-59166 Created by Independent Third Party: Yes Evaluation Reports FL10124 R20 AE 2017 09 FINAL ER GAF Asphalt Shingles FL10124-R20.pdf Created by Independent Third Party: Yes

[Back](#) [Next](#)

Contact Us :: [2601 Blair Stone Road, Tallahassee FL 32399](#) Phone: 850-487-1824

The State of Florida is an AA/EEO employer. [Copyright 2007-2013 State of Florida.](#) :: [Privacy Statement](#) :: [Accessibility Statement](#) :: [Refund Statement](#)

Under Florida law, email addresses are public records. If you do not want your e-mail address released in response to a public-records request, do not send electronic mail to this entity. Instead, contact the office by phone or by traditional mail. If you have any questions, please contact 850.487.1395. *Pursuant to Section 455.275(1), Florida Statutes, effective October 1, 2012, licensees licensed under Chapter 455, F.S. must provide the Department with an email address if they have one. The emails provided may be used for official communication with the licensee. However email addresses are public record. If you do not wish to supply a personal address, please provide the Department with an email address which can be made available to the public. To determine if you are a licensee under Chapter 455, F.S., please click [here](#).

Product Approval Accepts:



Credit Card
Safe





EXTERIOR RESEARCH & DESIGN, LLC.
 Certificate of Authorization #9503
 353 CHRISTIAN STREET, UNIT #13
 OXFORD, CT 06478
 (203) 262-9245

EVALUATION REPORT

GAF

1 Campus Drive
 Parsippany, NJ 07054
(800) 766-3411

Evaluation Report 01506.01.08-R22

FL10124-R20

Date of Issuance: 01/03/2008

Revision 22: 09/20/2017

SCOPE:

This Evaluation Report is issued under **Rule 61G20-3** and the applicable rules and regulations governing the use of construction materials in the State of Florida. The documentation submitted has been reviewed by Robert Nieminen, P.E. for use of the product under the Florida Building Code and Florida Building Code, Residential Volume. The products described herein have been evaluated for compliance with the **6th Edition (2017) Florida Building Code** sections noted herein.

DESCRIPTION: GAF Asphalt Roof Shingles

LABELING: Labeling shall be in accordance with the requirements the Accredited Quality Assurance Agency noted herein and **FBC 1507.2.7.1 / R905.2.6.1**.

CONTINUED COMPLIANCE: This Evaluation Report is valid until such time as the named product(s) changes, the referenced Quality Assurance documentation changes, or provisions of the Code that relate to the product change. Acceptance of this Evaluation Report by the named client constitutes agreement to notify Robert Nieminen, P.E. if the product changes or the referenced Quality Assurance documentation changes. Trinity|ERD requires a complete review of this Evaluation Report relative to updated Code requirements with each Code Cycle.

ADVERTISEMENT: The Evaluation Report number preceded by the words "Trinity|ERD Evaluated" may be displayed in advertising literature. If any portion of the Evaluation Report is displayed, then it shall be done in its entirety.

INSPECTION: Upon request, a copy of this entire Evaluation Report shall be provided to the user by the manufacturer or its distributors and shall be available for inspection at the job site at the request of the Building Official.

This Evaluation Report consists of pages 1 through 6.

Prepared by:



The facsimile seal appearing was authorized by Robert Nieminen, P.E. on 09/20/2017. This does not serve as an electronically signed document.

Robert J.M. Nieminen, P.E.

Florida Registration No. 59166, Florida DCA ANE1983

CERTIFICATION OF INDEPENDENCE:

1. Trinity|ERD does not have, nor does it intend to acquire or will it acquire, a financial interest in any company manufacturing or distributing products it evaluates.
2. Trinity|ERD is not owned, operated or controlled by any company manufacturing or distributing products it evaluates.
3. Robert Nieminen, P.E. does not have nor will acquire, a financial interest in any company manufacturing or distributing products for which the evaluation reports are being issued.
4. Robert Nieminen, P.E. does not have, nor will acquire, a financial interest in any other entity involved in the approval process of the product.
5. This is a building code evaluation. Neither Trinity|ERD nor Robert Nieminen, P.E. are, in any way, the Designer of Record for any project on which this Evaluation Report, or previous versions thereof, is/was used for permitting or design guidance unless retained specifically for that purpose.

ROOFING SYSTEMS EVALUATION:

1. SCOPE:

Product Category: Roofing
Sub-Category: Asphalt Shingles

Compliance Statement: GAF Asphalt Roof Shingles, as produced by GAF, have demonstrated compliance with the following sections of the 6th Edition (2017) Florida Building Code and Florida Building Code, Residential Volume through testing in accordance with the following Standards. Compliance is subject to the Installation Requirements and Limitations / Conditions of Use set forth herein.

2. STANDARDS:

<u>Section</u>	<u>Property</u>	<u>Standard</u>	<u>Year</u>
1507.2.4 / 1507.1.1, R905.2.3 / R905.1.1	Physical Properties	ASTM D1970	2015
1507.2.5, R905.2.4	Physical Properties	ASTM D3462	2010
1507.2.7.1, R905.2.6.1	Wind Resistance	ASTM D3161	2016
1507.2.7.1, R905.2.6.1	Wind Resistance	ASTM D7158	2011
1507.2.7.1, R905.2.6.1	Wind Resistance	TAS 107	1995

3. REFERENCES:

<u>Entity</u>	<u>Examination</u>	<u>Reference</u>	<u>Date</u>
GAF (PDM 1915)	Letter of Equivalency	Seal-A-Ridge Impact Resistant IR	01/13/2012
PRI (TST 5878)	Physical Properties	GAF-025-02-01	03/27/2002
PRI (TST 5878)	ASTM D3462	GAF-059-02-01	09/02/2004
PRI (TST 5878)	ASTM D3462	GAF-080-02-01	05/25/2005
PRI (TST 5878)	Physical Properties	GAF-324-02-01	12/01/2011
PRI (TST 5878)	Wind Driven Rain	GAF-407-02-01	01/21/2013
UL (TST 1740)	ASTM D3462	93NK6295	11/29/1993
UL (TST 1740)	ASTM D3462	99NK43835	01/12/2000
UL (TST 1740)	TAS 107	94NK9632	03/29/2000
UL (TST 1740)	ASTM D3462	01NK06632	02/02/2001
UL (TST 1740)	ASTM D3161, TAS 107	01NK9226	05/21/2001
UL (TST 1740)	ASTM D3161	01NK37122	12/18/2001
UL (TST 1740)	ASTM D3462	01NK37122	12/19/2001
UL (TST 1740)	ASTM D3161, TAS 107	02NK12980	04/10/2002
UL (TST 1740)	ASTM D3161, TAS 107	02NK30871	09/09/2002
UL (TST 1740)	ASTM D3161	03CA5367	03/11/2003
UL (TST 1740)	ASTM D3462	03NK26444	10/17/2003
UL (TST 1740)	ASTM D3462	04NK13850	06/07/2004
UL (TST 1740)	ASTM D3161	04NK13850	06/23/2004
UL (TST 1740)	ASTM D3161	04NK30546	03/10/2005
UL (TST 1740)	ASTM D3462	04NK22009	05/06/2005
UL (TST 1740)	ASTM D3161	04NK22009	05/09/2005
UL (TST 1740)	ASTM D3462	05NK27924	02/10/2006
UL (TST 1740)	ASTM D3161	05NK27924	02/11/2006
UL (TST 1740)	ASTM D3161, D3462	06CA18077	06/05/2006
UL (TST 1740)	ASTM D3161, D3462	06CA18074	06/16/2006
UL (TST 1740)	ASTM D3161, D3462	06CA35251	10/18/2006
UL (TST 1740)	ASTM D3462	06CA31603	12/01/2006
UL (TST 1740)	ASTM D3161, D3462	06CA41095	12/27/2006
UL (TST 1740)	ASTM D3161	07NK05228	03/13/2007
UL (TST 1740)	ASTM D3161	06CA31611	04/04/2007
UL (TST 1740)	ASTM D3161	06CA61148	04/09/2007
UL (TST 1740)	ASTM D3161, D3462	07CA31742	11/08/2007
UL (TST 1740)	ASTM D3161, D7158, D3462	08CA06100	03/13/2008

<u>Entity</u>	<u>Examination</u>	<u>Reference</u>	<u>Date</u>
UL (TST 1740)	ASTM D3161, D3462	07CA55908	04/01/2008
UL (TST 1740)	ASTM D3161, D3462	09CA10592	03/26/2009
UL (TST 1740)	ASTM D3161, D3462	09CA06856	05/15/2009
UL (TST 1740)	ASTM D3161, D7158, D3462	09NK06647	08/01/2009
UL (TST 1740)	ASTM D3161, D7158, D3462	09CA27281	08/27/2009
UL (TST 1740)	ASTM D3161, D7158, D3462	10CA35554	03/05/2010
UL (TST 1740)	ASTM D3161, D7158, D3462	10CA13686	05/15/2010
UL (TST 1740)	ASTM D3462	10CA07264	05/27/2010
UL (TST 1740)	ASTM D3462	10CA11953	10/29/2010
UL (TST 1740)	ASTM D3161, D7158, D3462	10NK11951	10/30/2010
UL (TST 1740)	ASTM D3161, D7158, D3462	10NK12070	11/04/2010
UL (TST 1740)	ASTM D3161, D7158, D3462	08CA06100	01/30/2010
UL (TST 1740)	ASTM D3161, D7158, D3462	10CA53934	03/31/2011
UL (TST 1740)	ASTM D3161, D7158, D3462	11CA48924	10/22/2011
UL (TST 1740)	ASTM D3161, D7158, D3462	11CA47919	12/03/2011
UL (TST 1740)	ASTM D3161, D7158, D3462	11CA48408	12/08/2011
UL (TST 1740)	ASTM D3161, D7158, D3462	11CA48725	12/09/2011
UL, LLC. (TST 9628)	ASTM D3462	12CA34891	10/12/2012
UL, LLC. (TST 9628)	ASTM D3161, D7158, D3462	12CA58151	02/15/2013
UL, LLC. (TST 9628)	ASTM D3161	12CA38083	02/26/2013
UL, LLC. (TST 9628)	ASTM D3161	13CA32332	06/18/2013
UL, LLC. (TST 9628)	ASTM D3161	13CA37934	08/02/2013
UL, LLC. (TST 9628)	ASTM D3161, D7158, D3462	4786875675	07/17/2015
UL, LLC. (TST 9628)	ASTM D3161, D7158, D3462	4787434542	05/17/2016
UL, LLC. (QUA 9625)	Quality Control	Inspection Report, R21, Mobile, AL	10/25/2016
UL, LLC. (QUA 9625)	Quality Control	Inspection Report, R21, Myerstown, PA	10/20/2016
UL, LLC. (QUA 9625)	Quality Control	Inspection Report, R21, Tuscaloosa, AL	11/11/2016
UL, LLC. (QUA 9625)	Quality Control	Inspection Report, R21, Michigan Cty, IN	11/01/2016
UL, LLC. (QUA 9625)	Quality Control	Inspection Report, R21, Shafter, CA	11/17/2016
UL, LLC. (QUA 9625)	Quality Control	Inspection Report, R21, Savannah, GA	11/11/2016
UL, LLC. (QUA 9625)	Quality Control	Inspection Report, R21, Minneapolis, MN	10/25/2016
UL, LLC. (QUA 9625)	Quality Control	Inspection Report, R21, Mt. Vernon, IN	10/25/2016
UL, LLC. (QUA 9625)	Quality Control	Inspection Report, R21, Baltimore, MD	10/21/2016
UL, LLC. (QUA 9625)	Quality Control	Inspection Report, R21, Tampa, FL	11/17/2016
UL, LLC. (QUA 9625)	Quality Control	Inspection Report, R21, Dallas, TX	11/04/2016
UL, LLC. (QUA 9625)	Quality Control	Inspection Report, R21, Ennis, TX	11/03/2016
UL, LLC. (QUA 9625)	Quality Control	Inspection Report, R21, Fontana, CA	11/01/2016

4. PRODUCT DESCRIPTION:

4.1 Asphalt Shingles:

- 4.1.1 Marquis® WeatherMax®, Royal Sovereign® and Sentinel® are a fiberglass reinforced 3-tab asphalt roof shingles.
- 4.1.2 Camelot®, Camelot® II, Fortitude™, Glenwood™, Grand Canyon®, Grand Sequoia®, Grand Sequoia® IR, Grand Sequoia® ArmorShield™, Monaco®, Sienna®, Timberline® American Harvest®, Timberline® ArmorShield™ II, Timberline® Natural Shadow®, Timberline HD®, Timberline® Cool Series®, Timberline Ultra HD® and Woodland® are fiberglass reinforced, laminated asphalt roof shingles.
- 4.1.3 Slateline® is a fiberglass reinforced 5-tab asphalt roof shingle.

4.2 Hip & Ridge Shingles:

- 4.2.1 Seal-A-Ridge® Ridge Cap Shingles, Seal-A-Ridge® IR Impact-Resistant Ridge Cap Shingles, Seal-A-Ridge® ArmorShield™ Ridge Cap Shingles and Timbertex® Premium Ridge Cap Shingles are fiberglass reinforced, hip and ridge asphalt roof shingles.

4.3 Accessory Starter Strips:

- 4.3.1 Pro-Start® Eave/Rake Starter Strip Shingles and WeatherBlocker™ Premium Eave/Rake Starter Strip Shingles are starter strips for asphalt roof shingles.
- 4.3.2 QuickStart® Peel & Stick Starter Roll is a mineral-surfaced, fiberglass-reinforced, self-adhering SBS modified bitumen starter strip, nominal 9-inch x 33 ft roll, for use with asphalt shingles with exposure of 6-inch or less.
- 4.3.3 StarterMatch™ Starter Strip Shingles are color-coordinated starter strips for use with Grand Canyon® and Grand Sequoia® series asphalt shingles. StarterMatch™ are installed as the second starter for Grand Canyon® and Grand Sequoia® series installations.

5. LIMITATIONS:

- 5.1 This is a building code evaluation. Neither Trinity|ERD nor Robert Nieminen, P.E. are, in any way, the Designer of Record for any project on which this Evaluation Report, or previous versions thereof, is/was used for permitting or design guidance unless retained specifically for that purpose.
- 5.2 This Evaluation Report is not for use in FBC HVHZ jurisdictions.
- 5.3 Fire Classification is not part of this Evaluation Report; refer to current Approved Roofing Materials Directory for fire ratings of this product.

5.4 Wind Classification:

- 5.4.1 The **GAF asphalt shingles** noted in **Section 4.1** are Classified in accordance with **FBC Tables 1507.2.7.1 and R905.2.6.1 to ASTM D3161, Class F** and/or **ASTM D7158, Class H**, indicating the shingles are acceptable for use in all wind zones up to $V_{asd} = 150$ mph ($V_{ult} = 194$ mph). Refer to Section 6 for installation requirements to meet this wind rating.
- 5.4.2 The **GAF hip & ridge shingles** noted in **Section 4.2** are Classified in accordance with **FBC Tables 1507.2.7.1 and R905.2.6.1 to ASTM D3161, Class F**, indicating the shingles are acceptable for use in all wind zones up to $V_{asd} = 150$ mph ($V_{ult} = 194$ mph). Refer to Section 6 for installation requirements to meet this wind rating.
- 5.4.3 Classification by **ASTM D7158** applies only to **exposure category B or C**, as defined in **FBC 1609.4.3**, and a **mean roof height of 60 feet or less**. Calculations by a qualified design professional are required for conditions outside these limitations. Contact the shingle manufacturer for data specific to each shingle.
- 5.5 All products in the roof assembly shall have quality assurance audit in accordance with **F.A.C. Rule 61G20-3**.

6. INSTALLATION:

6.1 Underlayment:

- 6.1.1 Underlayment shall be acceptable to **GAF** and shall hold current Florida Statewide Product Approval, or be Locally Approved per **Rule 61G20-3**, per **FBC 1507.2.3, 1507.2.4 or R905.2.3**.

6.2 Starter Shingles or Starter Strip:

- 6.2.1 Installation of **Pro-Start Eave/Rake Starter Strip Shingles, WeatherBlocker Premium Eave/Rake Starter Strip Shingles** and **QuickStart Peel & Stick Starter Roll** shall comply with the **GAF** current published instructions.

6.3 Asphalt Shingles:

- 6.3.1 Installation of asphalt shingles shall comply with the **GAF** current published instructions, using minimum four (4) nails per shingle in accordance with **FBC 1507.2.7 or R905.2.6**, with the following exceptions:
 - **Camelot, Camelot II, Grand Canyon, Grand Sequoia, Grand Sequoia IR, Grand Sequoia ArmorShield, and Woodland** require minimum five (5) nails per shingle.
 - **Slateline** requires minimum six (6) nails per shingle.
- 6.3.2 Fasteners shall be in accordance with manufacturer's published requirements, but not less than **FBC 1507.2.6 or R905.2.5**. Staples are not permitted.
- 6.3.3 Where the roof slope exceeds 21 units vertical in 12 units horizontal, special methods of fastening are required. Contact the **GAF** for details.

6.4 Hip & Ridge Shingles:

6.4.1 Installation of **Seal-A-Ridge Ridge Cap Shingles, Seal-A-Ridge IR Impact-Resistant Ridge Cap Shingles and Seal-A-Ridge ArmorShield Ridge Cap Shingles** shall comply with the GAF current published instructions with a minimum two (2) nails, minimum 3/8-inch head diameter, per shingle and nominal 0.25-inch diameter beads of **Henkel "Loctite PL S30 Roof & Flashing Sealant"**.

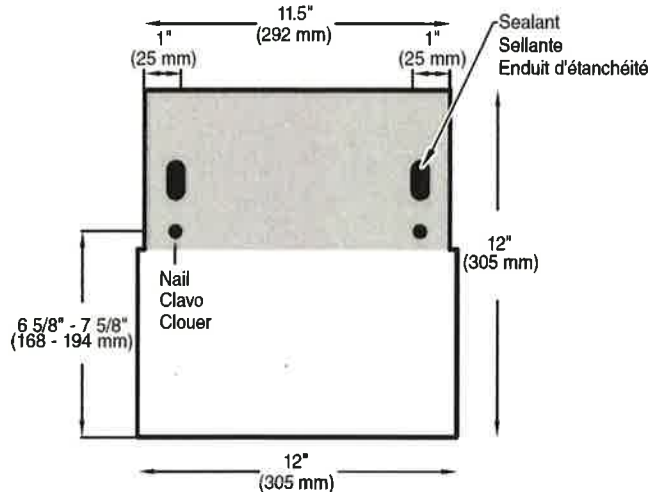

6.4.2 Installation of **Timbertex Premium Ridge Cap Shingles** shall comply with GAF current published instructions with a minimum two (2) nails, minimum 3/8-inch head diameter, per shingle and beads of **Sonneborn NP1 Gun Grade Polyurethane Sealant or Henkel PL Roofing and Flashing Sealant**.

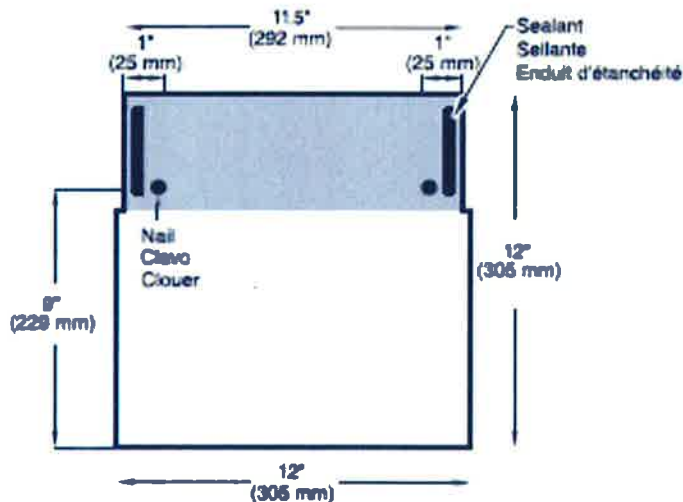

6.4.3 Fasteners shall be in accordance with GAF published requirements, but not less than **FBC 1507.2.6 or R905.2.5**. Staples are not permitted.

7. LABELING:

- 7.1 Labeling shall be in accordance with the requirements the Accredited Quality Assurance Agency noted herein.
- 7.2 Asphalt shingle wrappers shall indicate compliance with one of the required classifications detailed in **FBC Table 1507.2.7.1 / R905.2.6.1.**

8. BUILDING PERMIT REQUIREMENTS:

As required by the Building Official or Authority Having Jurisdiction in order to properly evaluate the installation of this product.

9. MANUFACTURING PLANTS:

Contact the named QA entity for information on which plants produce products covered by Florida Rule 61G20-3 QA requirements.

10. QUALITY ASSURANCE ENTITY:

UL LLC – QUA9625; (847) 664-3281

- END OF EVALUATION REPORT -



**STATE OF FLORIDA
DEPARTMENT OF BUSINESS AND PROFESSIONAL REGULATION**

**CONSTRUCTION INDUSTRY LICENSING BOARD
2601 BLAIR STONE ROAD
TALLAHASSEE FL 32399-0783**

(850) 487-1395

**LASCHNER, GERALD RAYMOND
JA EDWARDS OF AMERICA, INC.
2261 MULBRY DR
WINTER PARK FL 32789**

Congratulations! With this license you become one of the nearly one million Floridians licensed by the Department of Business and Professional Regulation. Our professionals and businesses range from architects to yacht brokers, from boxers to barbecue restaurants, and they keep Florida's economy strong.

Every day we work to improve the way we do business in order to serve you better. For information about our services, please log onto www.myfloridalicense.com. There you can find more information about our divisions and the regulations that impact you, subscribe to department newsletters and learn more about the Department's initiatives.

Our mission at the Department is: License Efficiently. Regulate Fairly. We constantly strive to serve you better so that you can serve your customers. Thank you for doing business in Florida and congratulations on your new license!



**STATE OF FLORIDA
DEPARTMENT OF BUSINESS AND
PROFESSIONAL REGULATION**

CCC057521 ISSUED: 08/14/2016

**CERTIFIED ROOFING CONTRACTOR
LASCHNER, GERALD RAYMOND
JA EDWARDS OF AMERICA, INC.**

IS CERTIFIED under the provisions of Ch. 489, F.S.
Expiration date: AUG 31, 2018 L1958140003281

DETACH HERE

RICK SCOTT, GOVERNOR

KEN LAWSON, SECRETARY

**STATE OF FLORIDA
DEPARTMENT OF BUSINESS AND PROFESSIONAL REGULATION
CONSTRUCTION INDUSTRY LICENSING BOARD**

LICENSE NUMBER

CCC057521

The ROOFING CONTRACTOR
Named below IS CERTIFIED
Under the provisions of Chapter 489, F.S.
Expiration date: AUG 31, 2018



**LASCHNER, GERALD RAYMOND
JA EDWARDS OF AMERICA, INC.
2261 MULBRY DR
WINTER PARK FL 32789**



ISSUED: 08/14/2016

DISPLAY AS REQUIRED BY LAW

REF # L1958140003281



CERTIFICATE OF LIABILITY INSURANCE

DATE (MM/DD/YYYY)

09/21/2017

THIS CERTIFICATE IS ISSUED AS A MATTER OF INFORMATION ONLY AND CONFERS NO RIGHTS UPON THE CERTIFICATE HOLDER. THIS CERTIFICATE DOES NOT AFFIRMATIVELY OR NEGATIVELY AMEND, EXTEND OR ALTER THE COVERAGE AFFORDED BY THE POLICIES BELOW. THIS CERTIFICATE OF INSURANCE DOES NOT CONSTITUTE A CONTRACT BETWEEN THE ISSUING INSURER(S), AUTHORIZED REPRESENTATIVE OR PRODUCER, AND THE CERTIFICATE HOLDER.

IMPORTANT: If the certificate holder is an ADDITIONAL INSURED, the policy(ies) must have ADDITIONAL INSURED provisions or be endorsed. If SUBROGATION IS WAIVED, subject to the terms and conditions of the policy, certain policies may require an endorsement. A statement on this certificate does not confer rights to the certificate holder in lieu of such endorsement(s).

PRODUCER Charlotte Insurance 6480-B South Blvd Charlotte, NC 28217	CONTACT NAME: Kathy Miller PHONE (A/C, H/O, F/O): 704-652-6888 E-MAIL ADDRESS: kathy@charlotteinsurance.com	FAX (A/C, H/O): 704-652-9547
	INSURER(S) AFFORDING COVERAGE	
INSURED JA Edwards of America Inc DBA Metropolitan Builders 7668 Stapoint Ct Winter Park, FL 32792-6680	INSURER A: American Compensation Insurance Co	SAC # 45934
	INSURER B:	
	INSURER C:	
	INSURER D:	
	INSURER E:	

COVERAGES

CERTIFICATE NUMBER: 00000000-0

REVISION NUMBER: 1

THIS IS TO CERTIFY THAT THE POLICIES OF INSURANCE LISTED BELOW HAVE BEEN ISSUED TO THE INSURED NAMED ABOVE FOR THE POLICY PERIOD INDICATED. NOTWITHSTANDING ANY REQUIREMENT, TERM OR CONDITION OF ANY CONTRACT OR OTHER DOCUMENT WITH RESPECT TO WHICH THIS CERTIFICATE MAY BE ISSUED OR MAY PERTAIN, THE INSURANCE AFFORDED BY THE POLICIES DESCRIBED HEREIN IS SUBJECT TO ALL THE TERMS, EXCLUSIONS AND CONDITIONS OF SUCH POLICIES. LIMITS SHOWN MAY HAVE BEEN REDUCED BY PAID CLAIMS.

TYPE OF INSURANCE	AGGREGATE LIMIT	POLICY NUMBER	POLICY EFF. DATE (MM/YYYY)	POLICY EXP. DATE (MM/YYYY)	LIMITS
COMMERCIAL GENERAL LIABILITY <input type="checkbox"/> CLAIMS MADE <input type="checkbox"/> OCCUR GEN. AGGREGATE LIMIT APPLIES FOR: <input type="checkbox"/> POLICY <input type="checkbox"/> PRODUCT <input type="checkbox"/> LOC <input type="checkbox"/> OTHER					EACH OCCURRENCE \$ DAMAGE TO RENTED PREMISES (if a contract) \$ BODILY INJURY (per person) \$ PERSONAL & ADJ. INJURY \$ GENERAL AGGREGATE \$ PRODUCTS - COMP/OP AGG \$ \$ \$
AUTOMOBILE LIABILITY <input type="checkbox"/> NON-AUTO <input type="checkbox"/> OWNED AUTOS ONLY <input type="checkbox"/> HIRED AUTOS ONLY <input type="checkbox"/> SCHEDULED AUTOS <input type="checkbox"/> NON-OWNED AUTOS ONLY					BODILY INJURY (per person) \$ BODILY INJURY (per accident) \$ PROPERTY DAMAGE (per accident) \$ \$ \$
UMBRELLA LMB PRODS LMB <input type="checkbox"/> OCCUR <input type="checkbox"/> CLAIMS MADE <input type="checkbox"/> COV. RETENTION \$					EACH OCCURRENCE \$ AGGREGATE \$ \$
WORKERS COMPENSATION AND EMPLOYERS LIABILITY ANY PROPRIETOR/PARTNER/EXECUTIVE OFFICER/OWNER EXCLUDED? (Mandatory in FL) If yes, describe under DESCRIPTION OF OPERATIONS below	<input checked="" type="checkbox"/> Y <input type="checkbox"/> N	NC-FL-045768-3	09/09/2017	09/09/2018	<input checked="" type="checkbox"/> YES <input type="checkbox"/> NO <input type="checkbox"/> COV.
					B.L. SICK ACCIDENT \$ 1,000,000 C.L. DISEASE - EA EMPLOYEE \$ 1,000,000 B.L. DISEASE - POLICY LIMIT \$ 1,000,000

DESCRIPTION OF OPERATIONS / LOCATIONS / VEHICLES (ACORD 101, Additional Remarks Schedule, may be attached if more space is required)

CERTIFICATE HOLDER

City of Belle Isle
 1600 Nola Avenue
 Belle Isle, FL 32809

CANCELLATION

SHOULD ANY OF THE ABOVE DESCRIBED POLICIES BE CANCELLED BEFORE THE EXPIRATION DATE THEREOF, NOTICE WILL BE DELIVERED IN ACCORDANCE WITH THE POLICY PROVISIONS.

AUTHORIZED REPRESENTATIVE

Kathy Miller

(KM2)

© 1988-2016 ACORD CORPORATION. All rights reserved.



JAEDWAR-01

DSMITH2

CERTIFICATE OF LIABILITY INSURANCE

DATE (MM/DD/YYYY)
04/24/2018

THIS CERTIFICATE IS ISSUED AS A MATTER OF INFORMATION ONLY AND CONFERS NO RIGHTS UPON THE CERTIFICATE HOLDER. THIS CERTIFICATE DOES NOT AFFIRMATIVELY OR NEGATIVELY AMEND, EXTEND OR ALTER THE COVERAGE AFFORDED BY THE POLICIES BELOW. THIS CERTIFICATE OF INSURANCE DOES NOT CONSTITUTE A CONTRACT BETWEEN THE ISSUING INSURER(S), AUTHORIZED REPRESENTATIVE OR PRODUCER, AND THE CERTIFICATE HOLDER.

IMPORTANT: If the certificate holder is an ADDITIONAL INSURED, the policy(ies) must have ADDITIONAL INSURED provisions or be endorsed. If SUBROGATION IS WAIVED, subject to the terms and conditions of the policy, certain policies may require an endorsement. A statement on this certificate does not confer rights to the certificate holder in lieu of such endorsement(s).

PRODUCER Hub International Florida 3760 N. Wickham Road Suite 2 Melbourne, FL 32935	CONTACT NAME:		
	PHONE (A/C, No, Ext):	(321) 255-2220	FAX (A/C, No): (321) 255-7770
INSURED JA Edwards of America Inc 7058 Stapoint Ct. Winter Park, FL 32792	E-MAIL ADDRESS:		
	INSURER(S) AFFORDING COVERAGE		NAIC #
	INSURER A:	Cincinnati Specialty Underwriters Ins Co	13037
	INSURER B:	Auto-Owners Insurance Company	18988
	INSURER C:		
	INSURER D:		
	INSURER E:		
	INSURER F:		

COVERAGES CERTIFICATE NUMBER: REVISION NUMBER:

THIS IS TO CERTIFY THAT THE POLICIES OF INSURANCE LISTED BELOW HAVE BEEN ISSUED TO THE INSURED NAMED ABOVE FOR THE POLICY PERIOD INDICATED. NOTWITHSTANDING ANY REQUIREMENT, TERM OR CONDITION OF ANY CONTRACT OR OTHER DOCUMENT WITH RESPECT TO WHICH THIS CERTIFICATE MAY BE ISSUED OR MAY PERTAIN, THE INSURANCE AFFORDED BY THE POLICIES DESCRIBED HEREIN IS SUBJECT TO ALL THE TERMS, EXCLUSIONS AND CONDITIONS OF SUCH POLICIES. LIMITS SHOWN MAY HAVE BEEN REDUCED BY PAID CLAIMS.

INSR LTR	TYPE OF INSURANCE	ADDL INSD	SUBR WVD	POLICY NUMBER	POLICY EFF (MM/DD/YYYY)	POLICY EXP (MM/DD/YYYY)	LIMITS
A	<input checked="" type="checkbox"/> COMMERCIAL GENERAL LIABILITY <input type="checkbox"/> CLAIMS-MADE <input checked="" type="checkbox"/> OCCUR GEN'L AGGREGATE LIMIT APPLIES PER: <input type="checkbox"/> POLICY <input checked="" type="checkbox"/> PRO-JECT <input checked="" type="checkbox"/> LOC OTHER:			CSU0098227	04/24/2018	04/24/2019	EACH OCCURRENCE \$ 1,000,000 DAMAGE TO RENTED PREMISES (Ea occurrence) \$ 300,000 MED EXP (Any one person) \$ 5,000 PERSONAL & ADV INJURY \$ 1,000,000 GENERAL AGGREGATE \$ 2,000,000 PRODUCTS - COMP/OP AGG \$ 2,000,000
B	AUTOMOBILE LIABILITY <input type="checkbox"/> ANY AUTO OWNED AUTOS ONLY <input checked="" type="checkbox"/> SCHEDULED AUTOS <input type="checkbox"/> HIRED AUTOS ONLY <input type="checkbox"/> NON-OWNED AUTOS ONLY			5088524401	09/22/2017	09/22/2018	COMBINED SINGLE LIMIT (Ea accident) \$ 1,000,000 BODILY INJURY (Per person) \$ BODILY INJURY (Per accident) \$ PROPERTY DAMAGE (Per accident) \$ Basic PIP \$ 10,000
A	<input checked="" type="checkbox"/> UMBRELLA LIAB <input checked="" type="checkbox"/> OCCUR <input type="checkbox"/> EXCESS LIAB <input type="checkbox"/> CLAIMS-MADE DED \$ RETENTION \$ 0			CSU0098230	04/24/2018	04/24/2019	EACH OCCURRENCE \$ 2,000,000 AGGREGATE \$ 2,000,000 Following Form <input type="checkbox"/> PER STATUTE <input type="checkbox"/> OTH-ER E.L. EACH ACCIDENT \$ E.L. DISEASE - EA EMPLOYEE \$ E.L. DISEASE - POLICY LIMIT \$
	WORKERS COMPENSATION AND EMPLOYERS' LIABILITY ANY PROPRIETOR/PARTNER/EXECUTIVE OFFICER/MEMBER EXCLUDED? (Mandatory in NH) <input type="checkbox"/> Y <input checked="" type="checkbox"/> N If yes, describe under DESCRIPTION OF OPERATIONS below		N/A				

DESCRIPTION OF OPERATIONS / LOCATIONS / VEHICLES (ACORD 101, Additional Remarks Schedule, may be attached if more space is required)

CERTIFICATE HOLDER City of Belle Isle 1600 Nela Avenue Belle Isle, FL 32809	CANCELLATION SHOULD ANY OF THE ABOVE DESCRIBED POLICIES BE CANCELLED BEFORE THE EXPIRATION DATE THEREOF, NOTICE WILL BE DELIVERED IN ACCORDANCE WITH THE POLICY PROVISIONS. AUTHORIZED REPRESENTATIVE 
--	--

Scott Randolph, Tax Collector Local Business Tax Receipt Orange County, Florida

This local business tax receipt is in addition to and not in lieu of any other tax required by law or municipal ordinance. Businesses are subject to regulation of zoning, health and other lawful authorities. This receipt is valid from October 1 through September 30 of receipt year. Delinquent penalty is added October 1.

2017 **EXPIRES 9/30/2018** 5000-1126097
 5000 BUSINESS OFFICE \$30.00 2 EMPLOYEE 1806 CERTIFIED ROOFING CO \$30.00 1 EMPLOYEE

TOTAL TAX \$60.00
 PREVIOUSLY PAID \$60.00
 TOTAL DUE \$0.00

EDWARDS JORDAN PRESIDENT
 LASCOBER GERALD RAYMOND QUALIFIER

JA EDWARDS OF AMERICA INC
 EDWARDS JORDAN
 7058 STAPOINT COURT
 WINTER PARK FL 32792

7058 STAPOINT CT
 U - WINTER PARK, 32792

PAID: \$60.00 0098-00771420 7/5/2017

Scott Randolph, Tax Collector Local Business Tax Receipt Orange County, Florida

This local business tax receipt is in addition to and not in lieu of any other tax required by law or municipal ordinance. Businesses are subject to regulation of zoning, health and other lawful authorities. This receipt is valid from October 1 through September 30 of receipt year. Delinquent penalty is added October 1.

2017 **EXPIRES 9/30/2018** 5000-1126097
 5000 BUSINESS OFFICE \$30.00 2 EMPLOYEE 1806 CERTIFIED ROOFING CO \$30.00 1 EMPLOYEE

TOTAL TAX \$60.00
 PREVIOUSLY PAID \$60.00
 TOTAL DUE \$0.00



EDWARDS JORDAN PRESIDENT
 LASCOBER GERALD RAYMOND QUALIFIER
 JA EDWARDS OF AMERICA INC
 EDWARDS JORDAN
 7058 STAPOINT COURT
 WINTER PARK FL 32792

7058 STAPOINT CT
 U - WINTER PARK, 32792

PAID: \$60.00 0098-00771420 7/5/2017

This receipt is official when validated by the Tax Collector.

[Searches](#)[Sales Search](#)[Results](#)[Property Record Card](#)[My Favorites](#)[Sign up for e-Notify...](#)**6619 Orange Knoll Dr** < 20-23-30-1678-00-580 >

Name(s)

Colpas Daniel

Mailing Address On File

529 Kingway Dr

Deltona, FL 32725-8602

Incorrect Mailing Address?

Physical Street Address

6619 Orange Knoll Dr

Postal City and Zipcode

Orlando, FL 32812

Property Use

0103 - Single Fam Class III

Municipality

Belle Isle

**View 2017 Property Record Card**[Property Features](#)[Values, Exemptions and Taxes](#)[Sales Analysis](#)[Location Info](#)[Market Stats](#)[Update Information](#)**2018 values will be available in August of 2018.****Property Description**

CONWAY LAKES 8/3 LOT 58

[View Plat](#)**Total Land Area** 10,005 sqft (+/-) | 0.23 acres (+/-) GIS Calculated Notice**Land**

Land Use Code	Zoning	Land Units	Unit Price	Land Value	Class Unit Price	Class Value
0100 - Single Family	R-1-AA	1 LOT(S)	working...	working...	working...	working...

Page 1 of 1 (1 total records)

Buildings

Important Information		Structure				
	Model Code:	01 - Single Fam Residence	Actual Year Built:	1980	Gross Area:	2956 sqft
	Type Code:	0103 - Single Fam Class III	Beds:	3	Living Area:	2088 sqft
	Building Value:	working...	Baths:	2.0	Exterior Wall:	Concrete Block Stucco
	Estimated New Cost:	working...	Floors:	1	Interior Wall:	Drywall

Page 1 of 1 (1 total records)

Extra Features

Description	Date Built	Units	XFOB Value
FPL2 - Average Fireplace	01/01/1980	1 Unit(s)	working...
PL2 - Above Average Pool	01/01/1980	1 Unit(s)	working...
SPA2 - Spa 2	09/20/2001	1 Unit(s)	working...

Page 1 of 1 (3 total records)

This Data Printed on 08/09/2018 and System Data Last Refreshed on 08/08/2018