



City of Belle Isle Job Site Card **Roof PERMIT 2018-07-056**

PERMIT MUST BE POSTED ON SITE - A permit expires in 6 months if approved inspections are not recorded /scheduled within that time frame. You are responsible for scheduling and keeping track of all your inspections -

Permit Number: 2018-07-056 Issue Date 7/26/2018
 Site Address: 5014 St Michael Ave 32812 Parcel Number: 17-23-30-4380-05-030
 Class: Residential Subdivision:
 Description of Work: Re-roof **2660 SQFT - Asphalt Shingles**

Issued To: RBS Construction LLC phone: 407 859 8163
 Name: Scott, Ron Contractor License CCC1327234
 Payment Date & Method: 8 / 1 / 2018
 Visa Master Card Amex Discover Check / Money Order # 7637

Schedule Inspections via Email at: BI scheduling@universalengineering.com
SCHEDULE INSPECTIONS BY 3:00 PM CUT OFF TIME
 Inspection Results Will Be Sent Out the Following Business Day

"WARNING TO OWNER: YOUR FAILURE TO RECORD A NOTICE OF COMMENCEMENT MAY RESULT IN YOUR PAYING TWICE FOR IMPROVEMENTS TO YOUR PROPERTY. IF YOU INTEND TO OBTAIN FINANCING, CONSULT WITH YOUR LENDER OR AN ATTORNEY BEFORE RECORDING YOUR NOTICE OF COMMENCEMENT."

ROOF	INSPECTOR	DATE	COMMENTS
------	-----------	------	----------

NEW ROOFS ONLY Code 700 Deck Nailing, Dry-In, Flashing			
Both new & re-roof Code 710 In - Progress			
Both new & re-roof Code 720 Final			

Inspection requests are to be emailed to BI scheduling@UniversalEngineering.com; a confirmation email will be sent back to you upon scheduling. **Next-Day Inspection requests must be made by 3:00pm.**

Please include the following in your request: Permit #, project address, type of inspection, date of the requested inspection, a contact name & a contact phone number. AM or PM may be requested but cannot be guaranteed.



City of Belle Isle

Universal Engineering Sciences 3532 Maggie Blvd., Orlando, FL 32811
Tel 407-581-8161 * Fax 407-581-0313 * www.universalengineering.com

JUL 25 2018

APPLICATION FOR ROOFING PERMIT

WARNING TO OWNER: YOUR FAILURE TO RECORD A NOTICE OF COMMENCEMENT MAY RESULT IN YOUR PAYING TWICE FOR IMPROVEMENTS TO YOUR PROPERTY. A NOTICE OF COMMENCEMENT MUST BE RECORDED AND POSTED ON THE JOB SITE BEFORE THE FIRST INSPECTION. IF YOU INTEND TO OBTAIN FINANCING, CONSULT WITH YOUR LENDER OR AN ATTORNEY BEFORE RECORDING YOUR NOTICE OF COMMENCEMENT.

DATE OF APPLICATION: 7/25/18 ROOF PERMIT NUMBER: 2018-07-056
PLEASE PRINT. The undersigned hereby applies for a permit to make installations as indicated below:

Project Address 5014 SAINT MICHAEL AVE, Belle Isle, FL 32809 ✓ 32812
Property Owner HEATHER DONTA Phone 321-662-2415
Property Owner's Mailing Address 5014 SAINT MICHAEL AVE City Belle Isle Fl. 32812
State FL Zip Code 32812 Parcel Id Number: 17 23 30 4380 05 030

REQUIRED! To obtain this information, please visit <http://www.ocpafi.org/Searches/ParcelSearch.aspx>

Class of Building: Old New Type of Building: Residential Commercial Other
Type of Work: New Roof ReRoof

REQUIRED! Florida Product Approval Form – NOTE: installation instructions must be posted on-site before your first inspection!!

Please indicate the nature of work by completing the information below:
Roof Square Footage: 2660 Number of Stories: 1 Job Valuation: \$ 10,868.13
Type: Asphalt Shingles Metal Modified Bitumen Other: _____

I hereby certify that the above is true and correct to the best of my knowledge and make Application for Permit as outlined above, and if same is granted I agree to conform to all Florida Building Code Regulations and City Ordinances regulating same and in accordance with plans submitted. The issuance of this permit does not grant permission to violate any applicable Town and/or State of Florida codes and/or ordinances. By signing below, I recognize Republic Services is by legal contract the sole authorized provider of garbage, recycling, yard waste, and commercial garbage and construction debris collection and disposal services with the city limits of the City. Contractors, homeowners and commercial businesses may contact Republic Services at 407-293-8000 to setup accounts for Commercial, Construction Roll Off, or other services needed. Rates are fixed by contract and are available at City Hall or from Republic Services. The City enforces the contract through its code enforcement office. Failure to comply will result in a stop work order.

LICENSE HOLDER SIGNATURE [Signature] LICENSE # CCC1327224
LICENSE HOLDER NAME CCC1327224 COMPANY NAME RBS Construction
Street Address 5205 S Orange Ave Suite 102
City Orlando State FL Zip Code 32809 Phone Number 407-899-8163
Email Address franzuas@rbsroofing.com

PAID
7/24/18
USA 7857

Zoning Fee	\$	<u>30.00</u>
Building Fee	\$	<u>75.00</u>
Review Fee	\$	<u>—</u>
1% BCAIB Fee	\$	<u>2.00</u>
1.5% DCA Fee	\$	<u>2.00</u>
Total Permit Fee	\$	<u>109.00</u>

Building Official: [Signature] Date 7-26-18
Verified Contractor's Licenses & Insurance are on file [Signature] Date 7.25.2018

NOTE: The Building Permit Number is required if the Roof Installation is associated with any construction or alteration where a Building Permit has been issued.
15 IK 25
10/5 50
75

Permit Number: 2018-07-056
 Folio/Parcel ID #: _____
 Prepared by: RBS CONSTRUCTION LLC
5205 S. ORANGE AVE #102
ORLANDO FL. 32803
 Return to: RBS CONSTRUCTION LLC

DOCH 20180437290
 07/24/2018 02:23:28 PM Page 1 of 1
 Rec Fee: \$10.00
 Phil Diamond, Comptroller
 Orange County, FL
 IP - Ret To: RBS CONSTRUCTION LLC



NOTICE OF COMMENCEMENT

State of Florida, County of Orange
 The undersigned hereby gives notice that improvement will be made to certain real property, and in accordance with Chapter 713, Florida Statutes, the following information is provided in this Notice of Commencement.

1. Description of property (legal description of the property, and street address if available)
LAKE CONWAY ESTATES SECTION TWO REPEAT X/150 LOT 3 BLKE
2. General description of improvement
REROOF AS PHALT SHINGLES
3. Owner information or Lessee information if the Lessee contracted for the improvement
 Name HEATHER DORTA
 Address 5014 SAINT MICHAEL AVE ORLANDO FL. 32812
 Interest in Property OWNER
 Name and address of fee simple titleholder (if different from Owner listed above)
 Name _____
 Address _____
4. Contractor
 Name RBS CONSTRUCTION LLC Telephone Number 407-859-8163
 Address 5205 S. ORANGE AVE #102 ORLANDO FL. 32803
5. Surety (if applicable, a copy of the payment bond is attached)
 Name _____ Telephone Number _____
 Address _____ Amount of Bond \$ _____
6. Lender
 Name _____ Telephone Number _____
 Address _____
7. Persons within the State of Florida designated by Owner upon whom notices or other documents may be served as provided by §713.13(1)(a)7, Florida Statutes.
 Name _____ Telephone Number _____
 Address _____
8. In addition to himself or herself, Owner designates the following to receive a copy of the Lienor's Notice as provided in §713.13(1)(b), Florida Statutes.
 Name _____ Telephone Number _____
 Address _____
9. Expiration date of notice of commencement (the expiration date will be 1 year from the date of recording unless a different date is specified) _____

WARNING TO OWNER: ANY PAYMENTS MADE BY THE OWNER AFTER THE EXPIRATION OF THE NOTICE OF COMMENCEMENT ARE CONSIDERED IMPROPER PAYMENTS UNDER CHAPTER 713, PART I, SECTION 713.13, FLORIDA STATUTES, AND CAN RESULT IN YOUR PAYING TWICE FOR IMPROVEMENTS TO YOUR PROPERTY. A NOTICE OF COMMENCEMENT MUST BE RECORDED AND POSTED ON THE JOB SITE BEFORE THE FIRST INSPECTION. IF YOU INTEND TO OBTAIN FINANCING, CONSULT WITH YOUR LENDER OR AN ATTORNEY BEFORE COMMENCING WORK OR RECORDING YOUR NOTICE OF COMMENCEMENT.

Heather Dorta _____
 Signature of Owner or Lessee, or Owner's or Lessee's Authorized Officer/Director/Partner/Manager
 Signature of owner
 Signatory's Title/Office

The foregoing instrument was acknowledged before me this 18th day of 10 2018 by Heather Dorta
 as _____ for _____
 Type of authority, e.g., officer, trustee, attorney in fact Name of party on behalf of whom instrument was executed

[Signature] _____
 Signature of Notary Public - State of Florida

 Print, type, or stamp commissioned name of Notary Public

Personally Known _____ OR Produced ID _____
 Type of ID Produced AA



Form content revised: 01/23/14

State of FLORIDA, County of ORANGE
 I hereby certify that this is a true copy of the document as reflected in the Official Records
 PHIL DIAMOND, COUNTY COMPTROLLER
 BY: [Signature] D.C.
 DATED: 7/24/18





Product Approval Form

DATE: 2018-07-05 PERMIT # 2018-07-056

PROJECT ADDRESS 5014 Saint Michael Ave, Belle Isle, FL 32809 32812

As required by Florida Statute 553.842 and Florida Administrative Code 9B-72m, please provide the information and approval numbers of the building components listed below if they will be utilized on the building or structure. FL Approved products are listed online at www.floridabuilding.org or can be obtained from the local product supplier. The following information must be turned in with permit application and available onsite for inspections:

1. This Product Approval Cover Sheet
2. Internet screen from FloridaBuilding.org showing PA#, approval and code edition stamped
3. Manufacturer's *installation* details from FloridaBuilding.org and requirements for each product stamped

Product Type	Manufacturer	Model/Series	FL Product Approval #	Product Type	Manufacturer	Model/Series	FL Product Approval #
EXTERIOR DOORS				WALL PANELS			
Swinging				Sliding			
Sliding				Soffits			
Sectional/Rollup				Storefront			
Other				Glass Block			
				Other			
WINDOWS				ROOFING PRODUCTS			
Single/Dbi Hung				Asphalt Shingles		<u>FL 544 R13 certified landmark</u>	
Horizontal Slider				Non Struct Metal			
Casement				Roofing Tiles			
Fixed				Single Ply Roof			
Mullion				Underlayment		<u>FL 1758 R17 certified landmark</u>	
Skylights				Other			
Other							
STRUCTURAL COMPONENTS				OTHER			
Wood Connectors							
Wood Anchors							
Truss Plates							
Insulation Forms							
Lintels							
Other							

It is the applicant's responsibility to verify that specific products have been installed in accordance with their limitations and with the minimum required design pressures for the structure. Specific compliance will be verified during field inspections.

Applicant Signature [Signature]

Date 7/25/18



Product Approval
USER: Public User

[Product Approval Menu](#) > [Product or Application Search](#) > [Application List](#) > **Application Detail**



FL #	FL5444-R13								
Application Type	Revision								
Code Version	2017								
Application Status	Approved								
Comments									
Archived	<input type="checkbox"/>								
Product Manufacturer	CertainTeed Corporation-Roofing								
Address/Phone/Email	20 Moores Road Malvern, PA 19355 (610) 893-5400 mark.d.harner@saint-gobain.com								
Authorized Signature	Mark Harner mark.d.harner@saint-gobain.com								
Technical Representative	Mark D. Harner								
Address/Phone/Email	18 Moores Road Malvern, PA 19355 (610) 651-5847 Mark.D.Harner@saint-gobain.com								
Quality Assurance Representative									
Address/Phone/Email									
Category	Roofing								
Subcategory	Asphalt Shingles								
Compliance Method	Evaluation Report from a Florida Registered Architect or a Licensed Florida Professional Engineer <input type="checkbox"/> Evaluation Report - Hardcopy Received								
Florida Engineer or Architect Name who developed the Evaluation Report	Robert Nieminen								
Florida License	PE-59166								
Quality Assurance Entity	UL LLC								
Quality Assurance Contract Expiration Date	03/09/2020								
Validated By	John W. Knezevich, PE <input checked="" type="checkbox"/> Validation Checklist - Hardcopy Received								
Certificate of Independence	FL5444 R13 COI 2018 01 COI NIEMINEN.pdf								
Referenced Standard and Year (of Standard)	<table border="0"> <thead> <tr> <th>Standard</th> <th>Year</th> </tr> </thead> <tbody> <tr> <td>ASTM D3161</td> <td>2016</td> </tr> <tr> <td>ASTM D3462</td> <td>2010</td> </tr> <tr> <td>ASTM D7158</td> <td>2011</td> </tr> </tbody> </table>	Standard	Year	ASTM D3161	2016	ASTM D3462	2010	ASTM D7158	2011
Standard	Year								
ASTM D3161	2016								
ASTM D3462	2010								
ASTM D7158	2011								
Equivalence of Product Standards Certified By									
Sections from the Code									
Product Approval Method	Method 1 Option D								
Date Submitted	01/24/2018								
Date Validated	01/29/2018								
Date Pending FBC Approval	01/30/2018								

Summary of Products

FL #	Model, Number or Name	Description
5444.1	CertainTeed Asphalt Roof Shingles	3-tab, 4-tab, strip (no-cut-outs), laminated and architectural asphalt roof shingles
Limits of Use Approved for use in HVHZ: No Approved for use outside HVHZ: Yes Impact Resistant: N/A Design Pressure: N/A Other: Refer to ER Section 5 for Limits of Use		Installation Instructions FL5444 R13 II 2018 01 FINAL ER CERTAINTEED ASPHALT SHINGLES FL5444-R13.pdf Verified By: Robert Nieminen, PE PE-59166 Created by Independent Third Party: Yes Evaluation Reports FL5444 R13 AE 2018 01 FINAL ER CERTAINTEED ASPHALT SHINGLES FL5444-R13.pdf Created by Independent Third Party: Yes

[Back](#) [Next](#)

Contact Us :: [2601 Blair Stone Road, Tallahassee, FL 32399](#) Phone: 850-487-1824

The State of Florida is an AA/EEO employer. [Copyright 2007-2013 State of Florida](#). :: [Privacy Statement](#) :: [Accessibility Statement](#) :: [Refund Statement](#)

Under Florida law, email addresses are public records. If you do not want your e-mail address released in response to a public-records request, do not send electronic mail to this entity. Instead, contact the office by phone or by traditional mail. If you have any questions, please contact 850.487.1395. *Pursuant to Section 455.275 (1), Florida Statutes, effective October 1, 2012, licensees licensed under Chapter 455, F.S. must provide the Department with an email address if they have one. The emails provided may be used for official communication with the licensee. However email addresses are public record. If you do not wish to supply a personal address, please provide the Department with an email address which can be made available to the public. To determine if you are a licensee under Chapter 455, F.S., please click [here](#).

Product Approval Accepts:





NEMO|etc.

Certificate of Authorization #32455
353 Christian Street, Unit #13
Oxford, CT 06478
(203) 262-9245

ENGINEER

EVALUATE

TEST

CONSULT

CERTIFY

EVALUATION REPORT

CertainTeed Corporation
20 Moores Road
Malvern, PA 19355
(610) 651-5847

Evaluation Report 3532.09.05-R14
FL5444-R13
Date of Issuance: 09/22/2005
Revision 14: 01/24/2018

SCOPE:

This Evaluation Report is issued under **Rule 61G20-3** and the applicable rules and regulations governing the use of construction materials in the State of Florida. The documentation submitted has been reviewed by Robert Nieminen, P.E. for use of the product under the Florida Building Code and Florida Building Code, Residential Volume. The products described herein have been evaluated for compliance with the **6th Edition (2017) Florida Building Code** sections noted herein.

DESCRIPTION: CertainTeed Asphalt Roof Shingles.

LABELING: Labeling shall be in accordance with the requirements of the Accredited Quality Assurance Agency noted herein and **FBC 1507.2.7.1 / R905.2.6.1**

CONTINUED COMPLIANCE: This Evaluation Report is valid until such time as the named product(s) changes, the referenced Quality Assurance documentation changes, or provisions of the Code that relate to the product change. Acceptance of this Evaluation Report by the named client constitutes agreement to notify Robert Nieminen, P.E. of any changes to the product(s), the Quality Assurance or the production facility location(s). NEMO|etc. requires a complete review of this Evaluation Report relative to updated Code requirements with each Code Cycle.

ADVERTISEMENT: The Evaluation Report number preceded by the words "NEMO|etc. Evaluated" may be displayed in advertising literature. If any portion of the Evaluation Report is displayed, then it shall be done in its entirety.

INSPECTION: Upon request, a copy of this entire Evaluation Report shall be provided to the user by the manufacturer or its distributors and shall be available for inspection at the job site at the request of the Building Official.

This Evaluation Report consists of pages 1 through 13.

Prepared by:

Robert J.M. Nieminen, P.E.
Florida Registration No. 59166, Florida DCA ANE1983

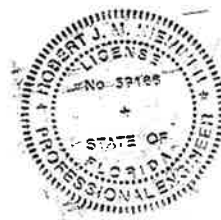

The facsimile seal appearing was authorized by Robert Nieminen, P.E. on 01/24/2018. This does not serve as an electronically signed document.

CERTIFICATION OF INDEPENDENCE:

1. NEMO|etc. does not have, nor does it intend to acquire or will it acquire, a financial interest in any company manufacturing or distributing products it evaluates.
2. NEMO|etc. is not owned, operated or controlled by any company manufacturing or distributing products it evaluates.
3. Robert Nieminen, P.E. does not have nor will acquire, a financial interest in any company manufacturing or distributing products for which the evaluation reports are being issued.
4. Robert Nieminen, P.E. does not have, nor will acquire, a financial interest in any other entity involved in the approval process of the product.
5. This is a building code evaluation. Neither NEMO|etc. nor Robert Nieminen, P.E. are, in any way, the Designer of Record for any project on which this Evaluation Report, or previous versions thereof, is/was used for permitting or design guidance unless retained specifically for that purpose.

ROOFING SYSTEMS EVALUATION:
1. SCOPE:

Product Category: Roofing
Sub-Category: Asphalt Shingles

Compliance Statement: CertainTeed Asphalt Roof Shingles, as produced by CertainTeed Corporation, have demonstrated compliance with the following sections of the 6th Edition (2017) Florida Building Code and 6th Edition (2017) Florida Building Code, Residential Volume through testing in accordance with the following Standards. Compliance is subject to the Installation Requirements and Limitations / Conditions of Use set forth herein.

2. STANDARDS:

<u>Section</u>	<u>Property</u>	<u>Standard</u>	<u>Year</u>
1507.2.5, R905.2.4	Physical Properties	ASTM D3462	2010
1507.2.7.1, R905.2.6.1	Wind Resistance	ASTM D3161	2016
1507.2.7.1, R905.2.6.1	Wind Resistance	ASTM D7158	2011

3. REFERENCES:

<u>Entity</u>	<u>Examination</u>	<u>Reference</u>	<u>Date</u>
UL (TST 1740)	ASTM D3161	94NK9632	05/15/1998
UL (TST 1740)	ASTM D3161	99NK26506	11/23/1999
UL (TST 1740)	ASTM D3161	03CA12702	05/27/2003
UL (TST 1740)	ASTM D3161	03CA12702	06/16/2003
UL (TST 1740)	ASTM D3161	03NK29847	10/03/2003
UL (TST 1740)	ASTM D3161	04CA11329	05/24/2004
UL (TST 1740)	ASTM D3161	04CA32986	12/03/2004
UL (TST 1740)	ASTM D3161	05NK07049	04/15/2005
UL (TST 1740)	ASTM D3161	05NK16778	05/12/2005
UL (TST 1740)	ASTM D3161	05CA16778	05/12/2005
UL (TST 1740)	ASTM D3161	05NK14836	05/22/2005
UL (TST 1740)	ASTM D3161	05NK22800	06/22/2005
UL (TST 1740)	ASTM D3462	R684	09/21/2005
UL (TST 1740)	ASTM D7158	05NK08037	06/28/2006
UL (TST 1740)	ASTM D3161 & D3462	09CA28873	07/23/2009
UL (TST 1740)	ASTM D3462	10CA41303	10/07/2010
UL (TST 1740)	ASTM D3161	10CA41303	10/08/2010
UL (TST 1740)	ASTM D7158	10CA41303	10/27/2010
UL (TST 1740)	ASTM D3161 & D3462	10CA44960	11/11/2010
UL LLC (TST 9628)	ASTM D3161, D3462 & D7158	13CA32897	11/21/2013
UL LLC (TST 9628)	ASTM D3161, D3462	TFWZ.R684	04/22/2014
UL LLC (TST 9628)	ASTM D7158	TGAH.R684	04/22/2014
UL LLC (TST 9628)	ASTM D3161 & D3462	4786334434	09/16/2014
UL LLC (TST 9628)	ASTM D3161 & D3462	4786570826	02/12/2015
UL LLC (TST 9628)	ASTM D3161, D3462 & D7158	4786570717	12/16/2015
UL LLC (TST 9628)	ASTM D3161 & D3462	4787195678	02/09/2016
UL LLC (TST 9628)	ASTM D3161, D3462 & D7158	4787380356	10/26/2016
UL LLC (TST 9628)	ASTM D3462	4787380357	10/13/2016
UL LLC (TST 9628)	ASTM D7158	4787380357	11/08/2016
UL LLC (TST 9628)	ASTM D3161	4787380357	11/09/2016
UL LLC (TST 9628)	ASTM D3161, D3462 & D7158	4787586427	01/25/2017
UL LLC (TST 9628)	ASTM D3161 & D3462	4788042412	11/15/2017
UL LLC (QUA 9625)	Quality Control	Service Confirmation	Exp. 03/09/2020

4. PRODUCT DESCRIPTION:

4.1 Asphalt Shingles:

- 4.1.1 **CT20™, XT™ 25, XT™ 30 and XT™ 30 IR** are fiberglass reinforced, 3-tab asphalt roof shingles.
- 4.1.2 **Arcadia™, Belmont®, Belmont® IR, Carriage House Shingle®, Grand Manor Shingle®, Landmark™, Landmark™ IR, Landmark™ Pro, Landmark™ Premium, Landmark™ TL, Landmark™ Solaris and Landmark™ Solaris IR** are fiberglass reinforced, laminated asphalt roof shingles.
- 4.1.3 **NorthGate™** is a fiberglass reinforced, laminated, SBS modified bitumen roof shingle.
- 4.1.4 **Presidential Shake™, Presidential Shake™ IR, Presidential Shake TL™ and Presidential Solaris™** are fiberglass reinforced, architectural asphalt roof shingles.
- 4.1.5 **Hatteras™, Highland Slate™ and Highland Slate™ IR** are fiberglass reinforced, 4-tab asphalt roof shingles.
- 4.1.6 **Patriot™** is a fiberglass reinforced asphalt roof strip-shingle (with no cut-outs) providing a laminated appearance through an intermittent shadow line with contrasting blend drops for color definition.

4.2 Hip & Ridge Shingles:

- 4.2.1 **Presidential Accessory, Accessory for Hatteras, Shingle Ridge™, Shadow Ridge™, Cedar Crest™, Cedar Crest™ IR, NorthGate Ridge and NorthGate Accessory** are fiberglass reinforced accessory shingles for hip and ridge installation.

4.3 Accessory Starter Strips:

- 4.3.1 **SwiftStart® Starter Shingle** is a starter strip for asphalt roof shingles. Its overall size of 15-1/4" x 38-3/4" yields two (2) 7-5/8" x 38-3/4" starter pieces per shingle.
- 4.4 Any of the above listed shingles may be produced in AR (algae resistant) versions.

5. LIMITATIONS:

- 5.1 This is a building code evaluation. Neither NEMO|etc. nor Robert Nieminen, P.E. are, in any way, the Designer of Record for any project on which this Evaluation Report, or previous versions thereof, is/was used for permitting or design guidance unless retained specifically for that purpose.
- 5.2 This Evaluation Report is not for use within FBC HVHZ jurisdictions.
- 5.3 Fire Classification is not part of this Evaluation Report; refer to current Approved Roofing Materials Directory for fire ratings of this product.
- 5.4 Wind Classification:
 - 5.4.1 All shingles noted herein are Classified in accordance with **FBC Tables 1507.2.7.1 and R905.2.6.1 to ASTM D3161, Class F and/or ASTM D7158, Class H**, indicating the shingles are acceptable for use in all wind zones up to $V_{asd} = 150$ mph ($V_{ult} = 194$ mph). Refer to Section 6 for installation requirements to meet this wind rating.
 - 5.4.2 **Presidential Accessory, Accessory for Hatteras, Shingle Ridge, Shadow Ridge, Cedar Crest, NorthGate Ridge and NorthGate Accessory hip & ridge shingles** have been evaluated in accordance with **ASTM D3161, Class F**. All except **NorthGate Ridge and NorthGate Accessory** require use of **BASF Sonolastic NP 1 adhesive** or **Henkel PL® Polyurethane Roof & Flashing Sealant**, applied as specified in manufacturer's application instructions, for use in wind zones up to $V_{asd} = 150$ mph ($V_{ult} = 194$ mph). Refer to Section 6 for installation requirements to meet this wind rating.
 - 5.4.3 **SwiftStart® Starter Shingle** has been evaluated in accordance with **ASTM D3161, Class F**. Refer to Section 6 for installation requirements to meet this wind rating.
 - 5.4.4 Classification by **ASTM D7158** applies to **exposure category B or C** and a **building height of 60 feet or less**. Calculations by a qualified design professional are required for conditions outside these limitations. Contact the shingle manufacturer for data specific to each shingle.

- 5.4.4.1 **Analysis in accordance with ASTM D7158** indicates the measured uplift resistance (R_T) for the CertainTeed asphalt Roof shingles listed in Section 4.1 through 4.6 (*except Presidential Solaris™*) exceeds the calculated uplift force (F_T) at a maximum design wind speed of $V_{asd} = 150$ mph ($V_{ult} = 194$ mph) for **residential buildings** located in **Exposure D conditions** with **no topographical variations (flat terrain)** having a **mean roof height less than or equal to 60 feet**. The shingles are permissible under Code for installation in these conditions using the installation procedures detailed in this Evaluation Report and CertainTeed minimum requirements, subject to minimum codified fastening requirements established within any local jurisdiction, which shall take precedence.
- 5.5 All products in the roof assembly shall have quality assurance audits in accordance with **FAC Rule 61G20-3**.

6. INSTALLATION:

- 6.1 Roof deck, slope, underlayment and fasteners shall comply with **FBC 1507.2 / R905.2** and the shingle manufacturer's minimum requirements.
- 6.1.1 Underlayment shall be acceptable to **CertainTeed Corporation** and shall hold current Florida Statewide Product Approval, or be Locally Approved per **Rule 61G20-3**, per **FBC Sections 1507.2.3, 1507.2.4 or R905.2.3**.
- 6.2 Installation of asphalt shingles shall comply with the **CertainTeed Corporation** current published instructions, using minimum four (4) nails per shingle in accordance with **FBC 1507.2.7 or Section R905.2.6** and the minimum requirements herein.
- 6.2.1 Fasteners shall be in accordance with manufacturer's published requirements, but not less than **FBC 1507.2.6 or R905.2.5**. Staples are not permitted.
- 6.2.2 Where the roof slope exceeds 21 units vertical in 12 units horizontal, use the "Steep Slope" directions.
- 6.3 CertainTeed asphalt shingles are acceptable for use in reroof (tear-off) or recover applications, subject to the limitations set forth in **FBC Section 1511 or R908** and CertainTeed published installation instructions.

6.4 SWIFTSTART® STARTER SHINGLE:

Fastening: Use four nails, located as shown below

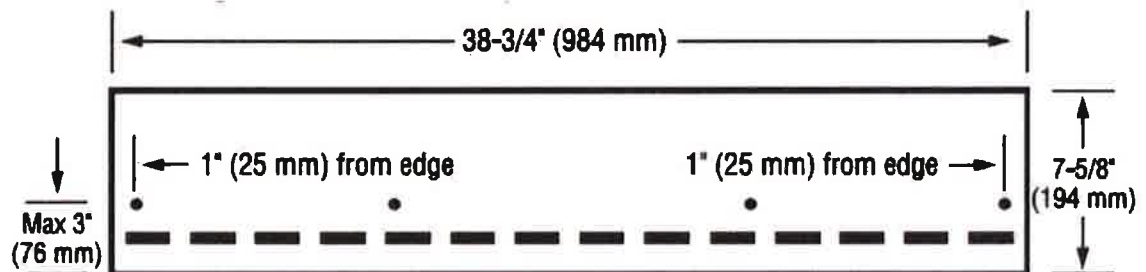

The inner two fasteners must be placed such that they fall at least 3" (76 mm) from the end joints of the shingle in the succeeding course.



6.5 CT20™, XT™ 25, XT™ 30, XT™ 30 IR:

LOW AND STANDARD SLOPE

ENGLISH

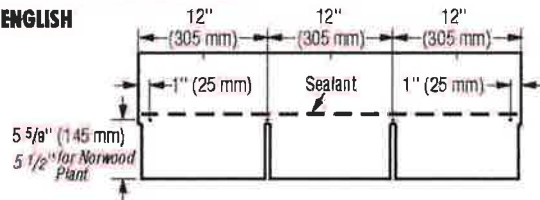

METRIC

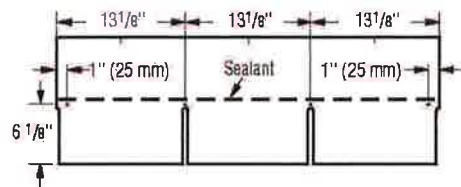
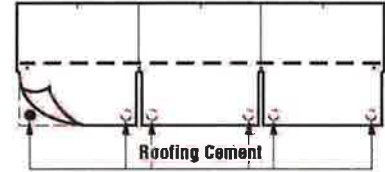

Figure 11-3: Use four nails for every full shingle.

STEEP SLOPE

Use four nails and six spots of asphalt roofing cement* for every full shingle (Figure 11-4). Asphalt roofing cement meeting ASTM D4586 Type II is suggested.



Apply 1" (25 mm) spots of asphalt roofing cement under each tab corner.

Figure 11-4: Use four nails and six spots of asphalt cement on steep slopes.

*CAUTION: Excessive use of roofing cement can cause shingles to blister.

6.5.1 Hip & Ridge for CT20™, XT™ 25, XT™ 30, XT™ 30 IR: Cut Shingles

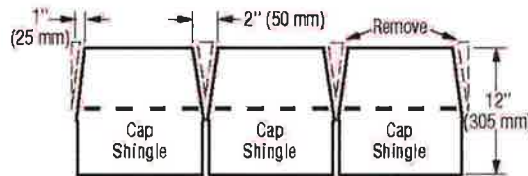

Figure 11-24: Cut tabs, then trim back to make cap shingles (English dimensions shown).

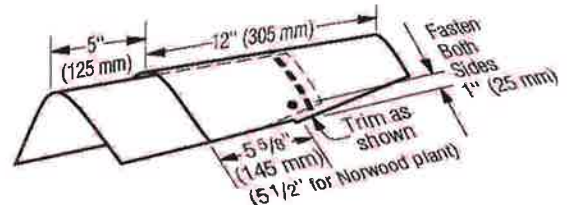

Figure 11-25: Installation of caps along the hips and ridges.

6.5.1.1 For ASTM D3161, Class F performance use BASF "Sonolastic® NP1™" adhesive or Henkel "PL® Polyurethane Roof & Flashing Sealant", in accordance with CertainTeed requirements.

6.6 ARCADIA™:

LOW AND STANDARD SLOPE

Use SIX nails for every full shingle located as shown below.

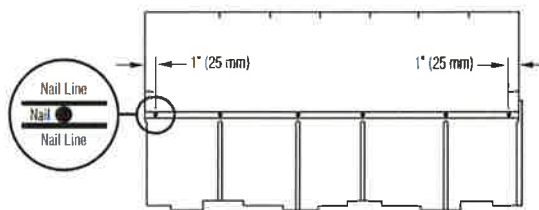

Figure 2: Use six nails for every full shingle.

STEEP SLOPE

Use SIX nails and FOUR spots of asphalt roofing cement for every full shingle as shown below. Apply asphalt roofing cement 1" (25 mm) from edge of shingle. Asphalt roofing cement meeting ASTM D 4586 Type II is suggested.

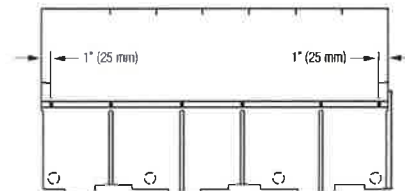

Figure 3: Use six nails and four spots of asphalt roofing cement on steep slopes.



6.6.1 **Hip & Ridge for Arcadia™: Cedar Crest™, Cedar Crest™ IR**

Use two (2), minimum 1¾-inch long fasteners per shingle. For the starter shingle, place fastener 1-inch from each side edge and about 2-inch up from the starter shingle’s exposed butt edge, ensuring minimum ¾-inch embedment into the deck, or full penetration through the deck. For each full Cedar Crest shingle, place fasteners 8-5/8-inch up from its exposed butt edge and 1-inch from each side edge.

For **ASTM D3161, Class F** performance use BASF “**Sonolastic® NP1™**” adhesive or Henkel “**PL® Polyurethane Roof & Flashing Sealant**”, in accordance with CertainTeed requirements, to **hand-seal Cedar Crest shingles**. Apply NP 1 or PL adhesive from the middle of the shingle’s raised overlay on the top piece and extending approximately 4-inch along the sides of the headlap along a line ¾ to 1-inch from each side of the shingle’s headlap. Immediately align and apply the overlying shingle, gently pressing tab sides into the adhesive, and install nails. To secure the other side, apply a 1-inch diameter spot of NP 1 or PL adhesive between the shingle layers.

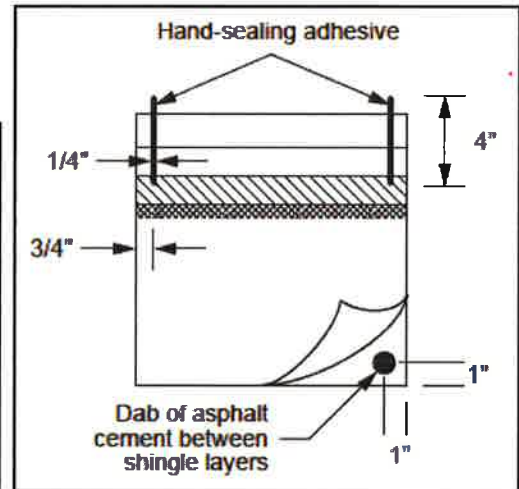
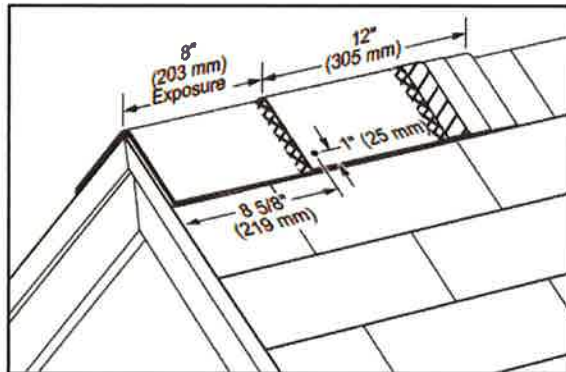

6.7 **BELMONT® OR BELMONT® IR:**

Low and Standard Slope (2:12 to 21:12):

Use **FIVE** nails for every full Belmont shingle, located as shown below.

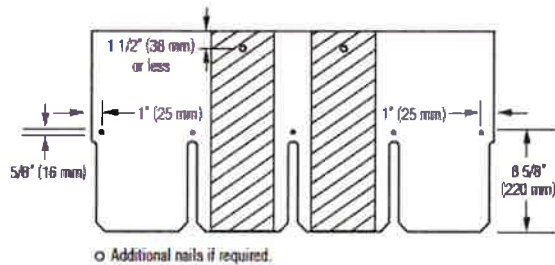

Steep Slope (greater than 21:12):

Use **SEVEN** nails and **EIGHT** spots of asphalt roofing cement** for every full Belmont shingle. Apply asphalt roofing cement 1 inch (25mm) from edge of shingle. See below. Asphalt roofing cement meeting ASTM D4586 Type II is suggested.

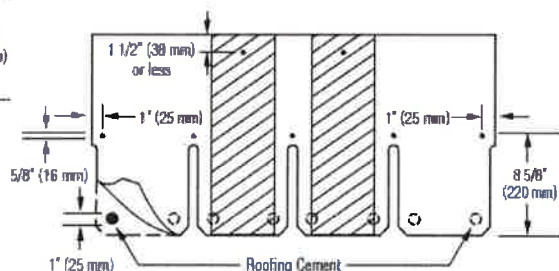



6.7.1 **Hip & Ridge for Belmont® or Belmont® IR:**

6.7.1.1 **Option 1:** For Belmont®, refer to instructions herein for Cedar Crest™ or Cedar Crest™ IR hip and ridge shingles. For Belmont® IR, refer to instructions herein for Cedar Crest™ IR hip and ridge shingles.

6.7.1.2 **Option 2:** For Belmont®: **Shangle® Ridge**

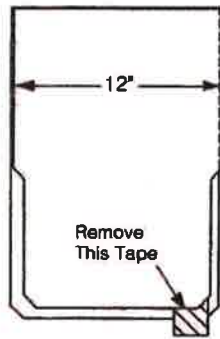

Figure 17-18: Shangle® Ridge.

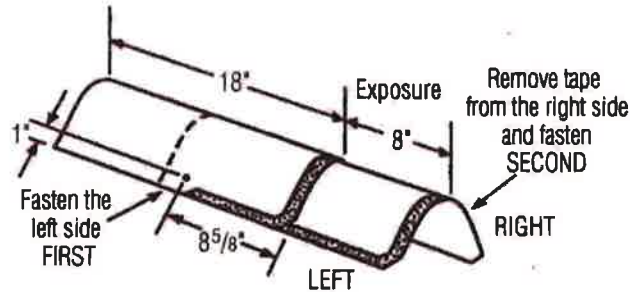

Figure 17-19: Installation of Shangle® Ridge shingles on hips and ridges.

6.7.1.3 For ASTM D3161, Class F performance use BASF “Sonolastic® NP1™” adhesive or Henkel “PL® Polyurethane Roof & Flashing Sealant”, in accordance with CertainTeed requirements.

6.8 CARRIAGE HOUSE SHANGLE® AND GRAND MANOR SHANGLE®:

LOW AND STANDARD SLOPE

Use five nails for every full Shangle.

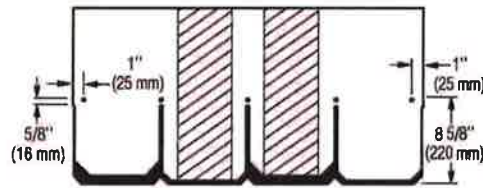

Figure 17-4: Use five nails for every full Grand Manor Shangle, Carriage House Shangle, or Centennial Slate.

STEEP SLOPE

Use seven nails and three spots of asphalt roofing cement for every full Grand Manor Shangle. Use five nails and three spots of asphalt roofing cement for every full Carriage House Shangle and Centennial Slate. Apply asphalt roofing cement 1" (25 mm) from edge of shingle (Figure 17-5). Asphalt roofing cement meeting ASTM D4586 Type II is suggested.

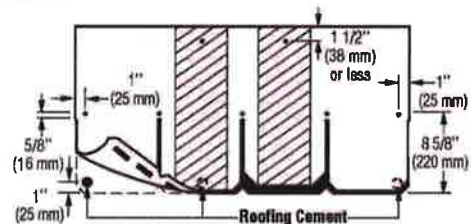

Figure 17-5: When installing Grand Manor Shangles on steep slopes, use seven nails and three spots of asphalt roofing cement.

6.8.1 **Hip & Ridge for Carriage House Shangle® and Grand Manor Shangle:** Refer to instructions herein for Shangle® Ridge hip and ridge shingles



6.9 LANDMARK™, LANDMARK™ IR, LANDMARK™ PRO, LANDMARK™ PREMIUM, LANDMARK™ TL, LANDMARK™ SOLARIS, LANDMARK™ SOLARIS IR, NORTHGATE:

LOW AND STANDARD SLOPE

LANDMARK TL

METRIC DIMENSIONS

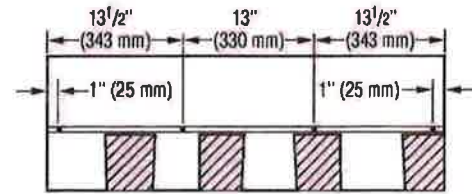
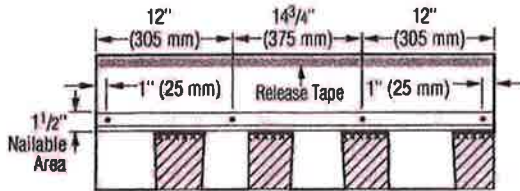
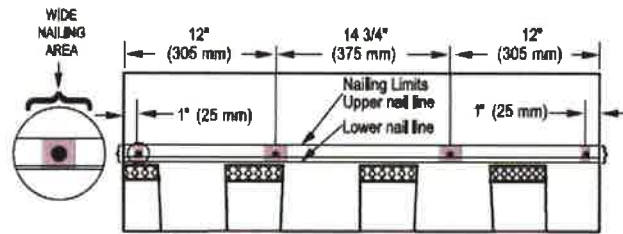

Figure 13-4: Use four nails for every full shingle.

NorthGate:



Nailing areas for low and standard slopes (from 2:12 to 21:12)
Nail between upper & lower lines as shown above.

STEEP SLOPE

Use six nails and four spots of asphalt roofing cement for every full laminated shingle. See below. Asphalt roofing cement should meet ASTM D4596 Type II. Apply 1\"/>

LANDMARK TL

METRIC DIMENSIONS

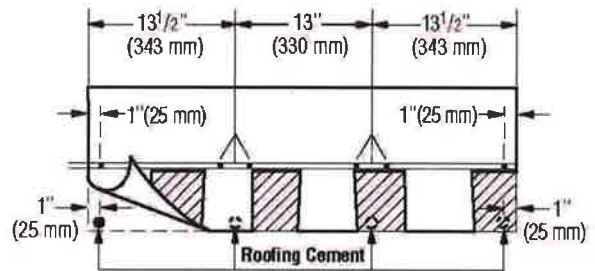
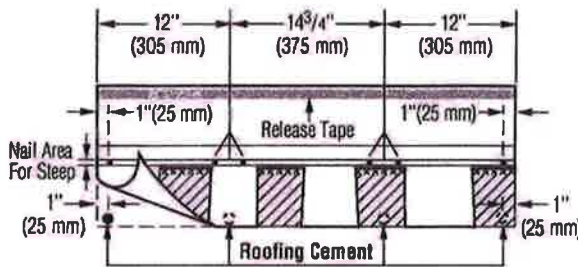
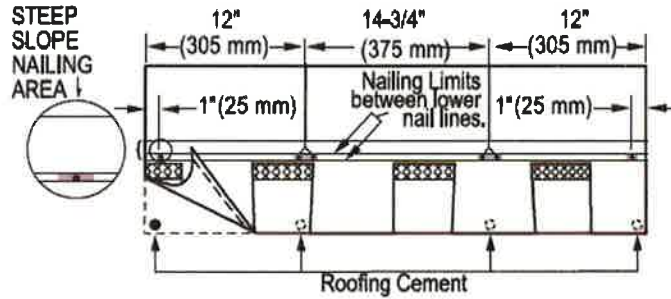

Figure 13-5: Use six nails and four spots of asphalt roofing cement on steep slopes.



NorthGate:



Nailing areas for steep slopes (greater than 21:12) and "Storm-Nailing"

Nail between lower 2 nail lines as shown above.

6.9.1 Hip & Ridge for Landmark™, Landmark™ IR, Landmark™ Pro, Landmark™ Premium, Landmark™ TL, Landmark™ Solaris, Landmark™ Solaris IR, NorthGate:

6.9.1.1 Option 1: Shadow Ridge™ or NothGate Accessory

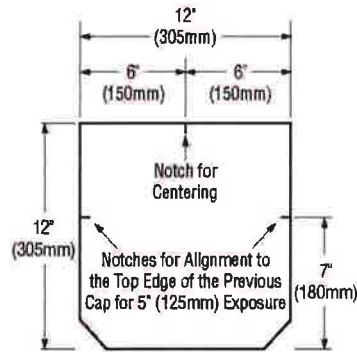

English Dimension Shadow Ridge™

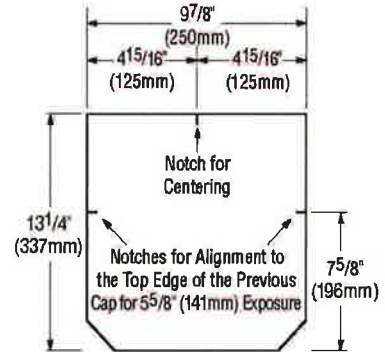

Metric Dimension Shadow Ridge™

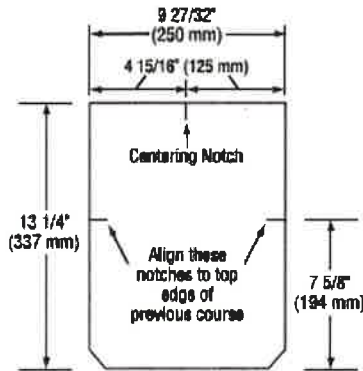

NorthGate Ridge

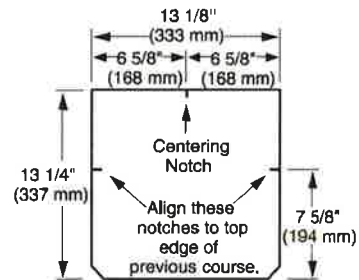

NorthGate Accessory

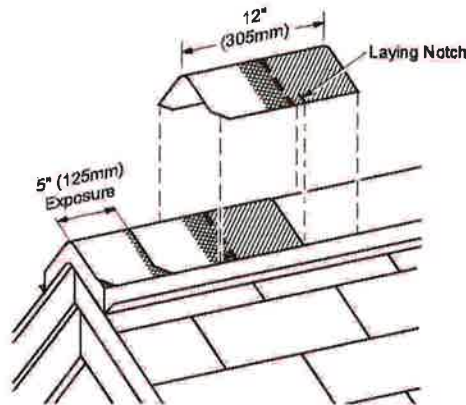

Figure 13-20: Use laying notches to center shingles on hips and ridges, and to locate the correct exposure.

- 6.9.1.2 For ASTM D3161, Class F performance use BASF “Sonolastic® NP1™” adhesive or Henkel “PL® Polyurethane Roof & Flashing Sealant”, in accordance with CertainTeed requirements.
- 6.9.1.3 **Option 2:** Refer to instructions herein for Cedar Crest™, Cedar Crest™ IR hip and ridge shingles.

6.10 PRESIDENTIAL SHAKE™, PRESIDENTIAL SHAKE™ IR, PRESIDENTIAL SHAKE TL™, PRESIDENTIAL SOLARIS™:

LOW AND STANDARD SLOPE:

For low and standard slopes, use five nails for each full Presidential shingle as shown below.

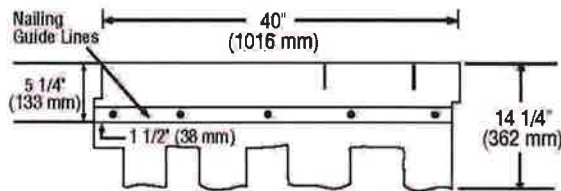

Figure 16-6: Fastening Presidential and Presidential TL Shake shingles on low and standard slopes.

STEEP SLOPE:

For steep slopes, use nine nails for each full Presidential shingle and apply 1" diameter spots of asphalt roofing cement under each shingle tab. After applying 5 nails in between the nailing guide lines, apply 4 nails 1" above tab cutouts making certain tabs of overlying shingle cover nails.

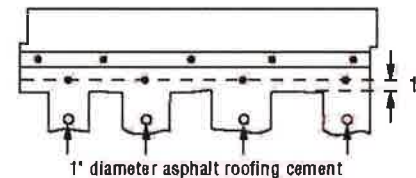

Figure 16-7: Fastening Presidential and Presidential TL Shake shingles on steep slopes.

6.10.1 Hip & Ridge for Presidential Shake™, Presidential Shake™ IR, Presidential Shake TL™, Presidential Solaris™:

6.10.1.1 Option 1: Presidential Accessory

PRESIDENTIAL ACCESSORY

Presidential accessory shingles can be used for covering hips and ridges. Apply shingles up to the ridge (expose no more than 7" from the bottom edge of the "tooth." Fasten each accessory with two fasteners. The fasteners must be 1 3/4" long or longer, so they penetrate either 3/4" into the deck or completely through the deck. Presidential accessory comes in two different sizes: Accessory produced in Birmingham, AL is 12" x 12"; Portland, OR produces 9 7/8" x 13 1/4" accessory.

- 6.10.1.2 For ASTM D3161, Class F performance use BASF “Sonolastic® NP1™” adhesive or Henkel “PL® Polyurethane Roof & Flashing Sealant”, in accordance with CertainTeed requirements.



6.10.1.3 **Option 2:** Refer to instructions herein for Cedar Crest™, Cedar Crest™ IR hip and ridge shingles.

6.11 HATTERAS™:

LOW, STANDARD AND STEEP SLOPE:

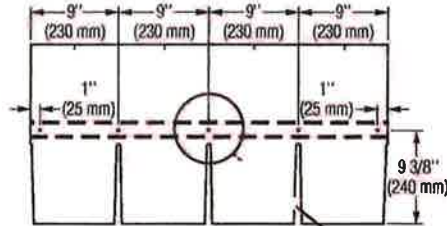

Figure 15-3: Fastening Hatteras Shingles on Low and Standard Slopes

For low and standard slopes, use five nails for each full Hatteras shingle as shown above.

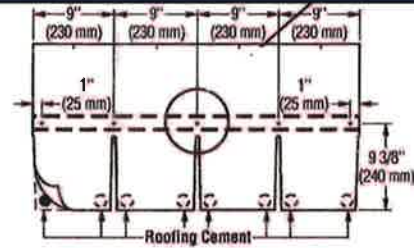

Figure 15-4: Fastening Hatteras Shingles on Steep Slopes

For steep slopes, use five nails and eight spots of asphalt roofing cement for each full Hatteras shingle as shown above. Apply 1" (25 mm) diameter spots of roofing cement (ASTM D 4586 Type II suggested) under each tab corner. Press shingle into place; do not expose cement.

CAUTION: Too much roofing cement can cause shingles to blister.

6.11.1 **Hip & Ridge for Hatteras™:**

6.11.1.1 **Option 1:** Accessory for Hatteras

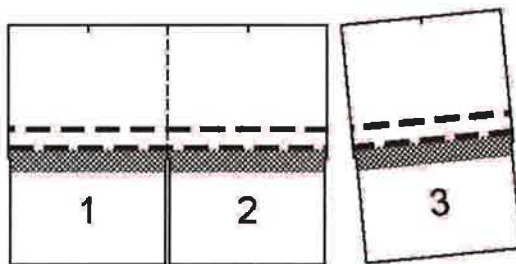
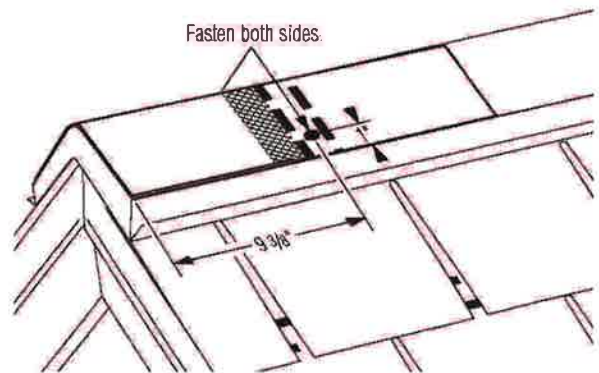

Figure 15-14: 18 three-piece units separate to make 54 Hatteras Accessory shingles.



6.11.1.2 **Option 2:** Cut Hatteras Shingles

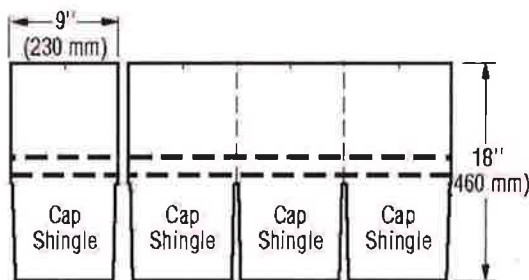

Figure 15-20: Cut Hatteras shingles to make cover cap.

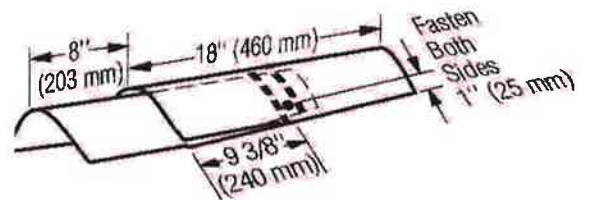

Figure 15-21: Installation of caps along hips and ridges.

6.11.1.3 For ASTM D3161, Class F performance use BASF "Sonolastic® NP1™" adhesive or Henkel "PL® Polyurethane Roof & Flashing Sealant", in accordance with CertainTeed requirements.



6.12 HIGHLAND SLATE™, HIGHLAND SLATE™ IR:

LOW AND STANDARD SLOPE:

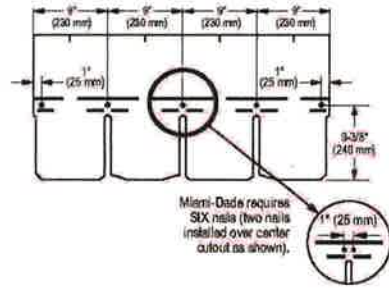

Figure 11-3: Use FIVE nails for every Highland Slate shingle.

STEEP SLOPE:

Use FIVE nails and EIGHT spots of asphalt roofing cement* for each full Highland Slate shingle. For Miami-Dade, SIX nails are required. Apply 1" diameter spots of asphalt roofing cement under each tab corner. Asphalt roofing cement meeting ASTM D4586 Type II is suggested.

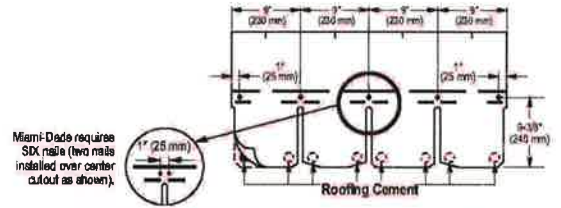

Figure 11-3A: Use FIVE nails and eight spots of asphalt roofing cement under each tab corner.

*CAUTION: Excessive use of roofing cement can cause shingles to blister.

6.12.1 Hip & Ridge for Highland Slate™, Highland Slate™ IR: Refer to instructions herein for Cedar Crest™, Cedar Crest™ IR or Shangle Ridge™ hip and ridge shingles.

6.13 PATRIOT™:

LOW AND STANDARD SLOPE

Use FOUR nails for every full shingle located as shown below.

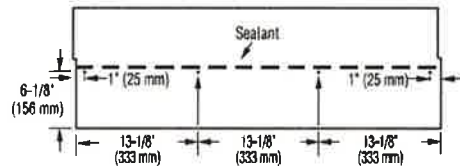

STEEP SLOPE

Use FOUR nails and four spots of asphalt roofing cement for every full shingle as shown below. Asphalt roofing cement meeting ASTM D4586 Type II is suggested. Apply 1" (25 mm) spots of asphalt roofing cement as shown.

CAUTION: Excessive use of roofing cement can cause shingles to blister.

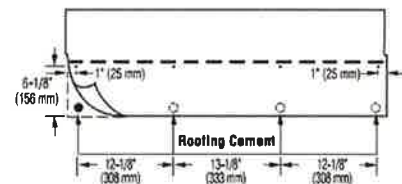

6.13.1 Hip & Ridge for Patriot™: Refer to instructions herein for Cedar Crest™, Cedar Crest™ IR, Shadow Ridge™, NorthGate or Shangle Ridge™ hip and ridge shingles.

7. LABELING:

7.1 Each unit shall bear a permanent label with the manufacturer's name, logo, city, state and logo of the Accredited Quality Assurance Agency noted herein.

7.2 Asphalt shingle wrappers shall indicate compliance with one of the required classifications detailed in FBC Table 1507.2.7.1 / R905.2.6.1.

8. BUILDING PERMIT REQUIREMENTS:

As required by the Building Official or Authority Having Jurisdiction in order to properly evaluate the installation of this product.

9. MANUFACTURING PLANTS:

Contact the named QA entity for information on which plants produce products covered by **Florida Rule 61G20-3** QA requirements.

10. QUALITY ASSURANCE ENTITY:

UL LLC – QUA9625; (414) 248-6409; karen.buchmann@us.ul.com

- END OF EVALUATION REPORT -



Product Approval
USER: Public User

[Product Approval Menu](#) > [Product or Application Search](#) > [Application List](#) > **Application Detail**

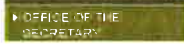

FL #	FL11288-R17																								
Application Type	Revision																								
Code Version	2017																								
Application Status	Approved																								
Comments																									
Archived	<input type="checkbox"/>																								
Product Manufacturer	CertainTeed Corporation-Roofing																								
Address/Phone/Email	20 Moores Road Malvern, PA 19355 (610) 893-5400 mark.d.harner@saint-gobain.com																								
Authorized Signature	Mark Harner mark.d.harner@saint-gobain.com																								
Technical Representative	Mark D. Harner																								
Address/Phone/Email	18 Moores Road Malvern, PA 19355 (610) 651-5847 Mark.D.Harner@saint-gobain.com																								
Quality Assurance Representative																									
Address/Phone/Email																									
Category	Roofing																								
Subcategory	Underlayments																								
Compliance Method	Evaluation Report from a Florida Registered Architect or a Licensed Florida Professional Engineer <input type="checkbox"/> Evaluation Report - Hardcopy Received																								
Florida Engineer or Architect Name who developed the Evaluation Report	Robert Nieminen																								
Florida License	PE-59166																								
Quality Assurance Entity	UL LLC																								
Quality Assurance Contract Expiration Date	03/09/2020																								
Validated By	John W. Knezevich, PE <input checked="" type="checkbox"/> Validation Checklist - Hardcopy Received																								
Certificate of Independence	FL11288 R17 COI 2018 01 COI NIEMINEN.pdf																								
Referenced Standard and Year (of Standard)	<table border="0"> <thead> <tr> <th>Standard</th> <th>Year</th> </tr> </thead> <tbody> <tr><td>ASTM D1970</td><td>2015</td></tr> <tr><td>ASTM D226</td><td>2009</td></tr> <tr><td>ASTM D4601</td><td>2012</td></tr> <tr><td>ASTM D4798</td><td>2011</td></tr> <tr><td>ASTM D4869</td><td>2016</td></tr> <tr><td>ASTM D6163</td><td>2008</td></tr> <tr><td>ASTM D6164</td><td>2011</td></tr> <tr><td>ASTM D6222</td><td>2011</td></tr> <tr><td>ASTM D6757</td><td>2016</td></tr> <tr><td>FM 4474</td><td>2011</td></tr> <tr><td>FRSA/TRI April 2012 (04-12)</td><td>2012</td></tr> </tbody> </table>	Standard	Year	ASTM D1970	2015	ASTM D226	2009	ASTM D4601	2012	ASTM D4798	2011	ASTM D4869	2016	ASTM D6163	2008	ASTM D6164	2011	ASTM D6222	2011	ASTM D6757	2016	FM 4474	2011	FRSA/TRI April 2012 (04-12)	2012
Standard	Year																								
ASTM D1970	2015																								
ASTM D226	2009																								
ASTM D4601	2012																								
ASTM D4798	2011																								
ASTM D4869	2016																								
ASTM D6163	2008																								
ASTM D6164	2011																								
ASTM D6222	2011																								
ASTM D6757	2016																								
FM 4474	2011																								
FRSA/TRI April 2012 (04-12)	2012																								
Equivalence of Product Standards Certified By																									
Sections from the Code																									

Product Approval Method

Method 1 Option D

Date Submitted

01/24/2018

Date Validated

01/29/2018

Date Pending FBC Approval

01/30/2018

Date Approved

04/10/2018

Summary of Products

FL #	Model, Number or Name	Description
11288.1	CertainTeed Roof Underlayments	Roof underlayments for use below Approved prepared roof coverings.
Limits of Use Approved for use in HVHZ: No Approved for use outside HVHZ: Yes Impact Resistant: N/A Design Pressure: +N/A/-555.0 Other: 1.) The DP in this application pertains to a particular application for use in adhesive-set tile applications. DP is N/A for underlayments installed beneath mechanically attached prepared roof covers. 2.) Refer to ER Section 5 for other Limits of Use.		Installation Instructions FL11288 R17 II 2018 01 FINAL ER CERTAINTEED UNDERLAYMENTS FL11288-R17.pdf Verified By: Robert Nieminen PE-59166 Created by Independent Third Party: Yes Evaluation Reports FL11288 R17 AE 2018 01 FINAL ER CERTAINTEED UNDERLAYMENTS FL11288-R17.pdf Created by Independent Third Party: Yes

[Back](#) [Next](#)

Contact Us :: [2601 Blair Stone Road, Tallahassee FL 32399](#) Phone: 850-487-1824

The State of Florida is an AA/EEO employer. [Copyright 2007-2013 State of Florida.](#) :: [Privacy Statement](#) :: [Accessibility Statement](#) :: [Refund Statement](#)

Under Florida law, email addresses are public records. If you do not want your e-mail address released in response to a public-records request, do not send electronic mail to this entity. Instead, contact the office by phone or by traditional mail. If you have any questions, please contact 850.487.1395. *Pursuant to Section 455.275 (1), Florida Statutes, effective October 1, 2012, licensees licensed under Chapter 455, F.S. must provide the Department with an email address if they have one. The emails provided may be used for official communication with the licensee. However email addresses are public record. If you do not wish to supply a personal address, please provide the Department with an email address which can be made available to the public. To determine if you are a licensee under Chapter 455, F.S., please click [here](#).





NEMO|etc.

Certificate of Authorization #32455
353 Christian Street, Unit #13
Oxford, CT 06478
(203) 262-9245

ENGINEER

EVALUATE

TEST

CONSULT

CERTIFY

EVALUATION REPORT

CertainTeed Corporation
20 Moores Road
Malvern, PA 19355
(610) 651-5847

Evaluation Report 11610.09.08-R18
FL11288-R17
Date of Issuance: 09/03/2009
Revision 18: 01/24/2018

SCOPE:

This Evaluation Report is issued under **Rule 61G20-3** and the applicable rules and regulations governing the use of construction materials in the State of Florida. The documentation submitted has been reviewed by Robert Nieminen, P.E. for use of the product under the Florida Building Code and Florida Building Code, Residential Volume. The products described herein have been evaluated for compliance with the **6th Edition (2017) Florida Building Code** sections noted herein.

DESCRIPTION: CertainTeed Roof Underlayments

LABELING: Labeling shall be in accordance with the requirements the Accredited Quality Assurance Agency noted herein.

CONTINUED COMPLIANCE: This Evaluation Report is valid until such time as the named product(s) changes, the referenced Quality Assurance documentation changes, or provisions of the Code that relate to the product change. Acceptance of this Evaluation Report by the named client constitutes agreement to notify Robert Nieminen, P.E. of any changes to the product(s), the Quality Assurance or the production facility location(s). NEMO|etc. requires a complete review of this Evaluation Report relative to updated Code requirements with each Code Cycle.

ADVERTISEMENT: The Evaluation Report number preceded by the words "NEMO|etc. Evaluated" may be displayed in advertising literature. If any portion of the Evaluation Report is displayed, then it shall be done in its entirety.

INSPECTION: Upon request, a copy of this entire Evaluation Report shall be provided to the user by the manufacturer or its distributors and shall be available for inspection at the job site at the request of the Building Official.

This Evaluation Report consists of pages 1 through 10.

Prepared by:

Robert J.M. Nieminen, P.E.
Florida Registration No. 59166, Florida DCA ANE1983



The facsimile seal appearing was authorized by Robert Nieminen, P.E. on 01/24/2018. This does not serve as an electronically signed document.

CERTIFICATION OF INDEPENDENCE:

1. NEMO ETC, LLC does not have, nor does it intend to acquire or will it acquire, a financial interest in any company manufacturing or distributing products it evaluates.
2. NEMO ETC, LLC is not owned, operated or controlled by any company manufacturing or distributing products it evaluates.
3. Robert Nieminen, P.E. does not have nor will acquire, a financial interest in any company manufacturing or distributing products for which the evaluation reports are being issued.
4. Robert Nieminen, P.E. does not have, nor will acquire, a financial interest in any other entity involved in the approval process of the product.
5. This is a building code evaluation. Neither NEMO ETC, LLC nor Robert Nieminen, P.E. are, in any way, the Designer of Record for any project on which this Evaluation Report, or previous versions thereof, is/was used for permitting or design guidance unless retained specifically for that purpose.



ROOFING COMPONENT EVALUATION:

1. SCOPE:

Product Category: Roofing
Sub-Category: Underlayment

Compliance Statement: CertainTeed Roof Underlayments, as produced by CertainTeed Corporation, have demonstrated compliance with the following sections of the 6th Edition (2017) Florida Building Code through testing in accordance with the following Standards. Compliance is subject to the Installation Requirements and Limitations / Conditions of Use set forth herein.

2. STANDARDS:

Table with 4 columns: Section, Property, Standard, Year. Lists various building code sections and their corresponding standards and years.

3. REFERENCES:

Table with 4 columns: Entity, Examination, Reference, Date. Lists various testing entities, examination types, reference codes, and dates.



Entity
PRI (TST5878)
UL, LLC. (QUA9625)

Examination
Physical Properties
Quality Control

Reference
CTC-327-02-01
Service Confirmation

Date
06/28/2017
Exp. 03/09/2020

4. PRODUCT DESCRIPTION:

4.1 Self-Adhering Underlayments:

4.1.1 **WinterGuard™ HT** is a glass scrim reinforced, self-adhering, film-surfaced waterproofing underlayment; meets ASTM D1970.

4.1.2 **WinterGuard™ Sand** is a glass mat reinforced, self-adhering, sand-surfaced waterproofing underlayment; meets ASTM D1970.

4.1.3 **WinterGuard™ Granular** is a glass mat reinforced, self-adhering, granule-surfaced waterproofing underlayment; meets ASTM D1970.

4.1.4 **MetaLayment™** is a self-adhering, film-surfaced, waterproofing underlayment; meets ASTM D1970.

4.1.5 **Black Diamond Base Sheet** is a self-adhering, glass mat reinforced, fine-mineral surfaced, SBS modified roof underlayment; meets ASTM D1970.

4.1.6 **Flintlastic SA PlyBase** is a self-adhering, glass mat reinforced, film-surfaced, SBS modified roof underlayment for use as a base-layer in multi-ply underlayment systems; meets ASTM D1970.

4.1.7 **Flintlastic SA Mid Ply** is a self-adhering, polyester reinforced, film-surfaced, SBS modified roof underlayment for use as a base-layer in multi-ply underlayment systems; meets ASTM D6163, Type I, Grade S.

4.1.8 **Flintlastic Ultra Glass SA** is a self-adhering, glass mat reinforced, fine-mineral surfaced, SBS modified roof underlayment for use as a base-layer in multi-ply underlayment systems; meets ASTM D6163, Type I, Grade S.

4.1.9 **Flintlastic SA Cap FR** is a self-adhering, glass mat reinforced, granule-mineral surfaced, SBS modified roof underlayment; meets ASTM D6163, Type I, Grade G.

4.1.10 **Flintlastic SA Cap** is a self-adhering, polyester reinforced, granule-mineral surfaced, SBS modified roof underlayment; meets ASTM D1970, ASTM D6164, Type I, Grade G and FRSA/TRI April 2012.

4.2 Torch Applied Underlayments:

4.2.1 **Flintlastic GTA** is a torch-applied, polyester reinforced, granule-surfaced, APP modified roof underlayment; meets ASTM D6222, Type I, Grade G.

4.3 Asphalt Applied Underlayments:

4.3.1 **Flintlastic GMS** is an asphalt-applied, polyester reinforced, granule-surfaced, SBS modified roof underlayment; meets ASTM D6164, Type I, Grade G.

4.4 Mechanically Attached Underlayments:

4.4.1 **Flintlastic SA NailBase** is a glass mat reinforced, film-surfaced, SBS modified roof underlayment for use as a mechanically attached base-layer in multi-ply underlayment systems; meets ASTM D4601, Type II.

4.4.2 **Roofers' Select** is an asphalt-impregnated, organic felt reinforced with glass fibers roof underlayment; meets ASTM D6757.

5. LIMITATIONS:

- 5.1 This is a building code evaluation. Neither NEMO ETC, LLC nor Robert Nieminen, P.E. are, in any way, the Designer of Record for any project on which this Evaluation Report, or previous versions thereof, is/was used for permitting or design guidance unless retained specifically for that purpose.
- 5.2 This Evaluation Report is not for use in **FBC HVHZ** jurisdictions.
- 5.3 Fire Classification is not part of this Laboratory Report; refer to current Approved Roofing Materials Directory or test report from accredited testing agency for fire ratings of this product.
- 5.4 **CertainTeed Roof Underlayments** may be used with any prepared roof cover where the product is specifically referenced within FBC approval documents. If not listed, a request may be made to the Authority Having Jurisdiction (AHJ) for approval based on this evaluation combined with supporting data for the prepared roof covering.
- 5.5 Allowable Roof Covers:

TABLE 1: ROOF COVER OPTIONS							
Underlayment	Asphalt Shingles	Nail-On Tile	Foam-On Tile	Mortar-Set Tile	Metal	Wood Shakes & Shingles	Slate
Roofers' Select	Yes	No	No	No	No	No	No
WinterGuard HT	Yes	No	No	No	Yes	Yes	Yes
WinterGuard Sand or Granular	Yes	No	No	No	No	Yes	Yes
Black Diamond Base	Yes	No	No	No	No	Yes	Yes
Flintlastic SA Cap	Yes	Yes	Yes <i>See 5.5.1</i>	Yes	No	Yes	Yes
Flintlastic SA Cap FR	No	No	No	No	No	Yes	Yes
MetaLayment	Yes	No	No	No	Yes	Yes	Yes
Flintlastic GTA	No	Yes	Yes <i>See 5.5.1</i>	Yes	No	Yes	Yes
Flintlastic GMS	No	Yes	Yes <i>See 5.5.1</i>	Yes	No	Yes	Yes

- 5.5.1 "Foam-On Tile" is limited to use of the following Approved tile adhesives / underlayment combinations.

TABLE 1A: ALLOWABLE TILE ADHESIVE / UNDERLAYMENT COMBINATIONS ¹		
Adhesive	Florida Product Approval	Underlayments
Dow TileBond™	FL22525	Flintlastic SA Cap or Flintlastic GMS
ICP Adhesives Polyset® AH-160	FL6332	Flintlastic SA Cap, Flintlastic GTA or Flintlastic GMS

¹ Refer to Tile Manufacturer's or Adhesive Manufacturer's Florida Product Approval for Overturning Moment Resistance Performance.

5.6 Allowable Substrates:

5.6.1 Direct-Bond to Deck:

WinterGuard HT, WinterGuard Sand, WinterGuard Granular or MetaLayment self-adhered to:

- New or existing plywood
- FlintPrime or ASTM D41 primed new or existing plywood.

Black Diamond Base, Flintlastic SA PlyBase, Flintlastic SA Mid Ply, Flintlastic Ultra Glass SA, Flintlastic SA Cap or Flintlastic SA Cap FR self-adhered to:

- New or existing plywood;
- FlintPrime, FlintPrime SA or ASTM D41 primed new or existing plywood;
- FlintPrime, FlintPrime SA or ASTM D41 primed structural concrete.

Flintlastic GMS in hot asphalt to:

- FlintPrime or ASTM D41 primed structural concrete.

Flintlastic GTA torch-applied to:

- FlintPrime or ASTM D41 primed structural concrete.

5.6.2 Bond to Mechanically Attached Base Sheet or Adhered Base Ply:

- WinterGuard HT, WinterGuard Sand, WinterGuard Granular or MetaLayment self-adhered to: ASTM D226, Type I or II felt.
- Black Diamond Base Sheet, Flintlastic SA PlyBase, Flintlastic SA Mid Ply, Flintlastic Ultra Glass SA, Flintlastic SA Cap, Flintlastic SA Cap FR self-adhered to: Flintlastic SA NailBase or ASTM D226, Type I or II felt.
- Flintlastic SA Cap or Flintlastic SA Cap FR self-adhered to: Flintlastic SA PlyBase or Flintlastic SA MidPly.
- Flintlastic GMS in hot asphalt to: ASTM D226, Type I or II felt, ASTM D4601, Type II base sheet, Black Diamond Base Sheet or Flintlastic Ultra Glass SA.
- Flintlastic GTA torch-applied to: ASTM D226, Type I or II felt, ASTM D4601, Type II base sheet, Black Diamond Base Sheet or Flintlastic Ultra Glass SA.

5.6.3 Wind Resistance for Underlayment Systems in Foam-On Tile Applications:

FRSA/TRI April 2012 (04-12) does not address wind uplift resistance of all underlayment systems beneath foam-on or mortar-set tile systems, where the underlayment forms part of the load-path. The following wind uplift limitations apply to underlayment systems that are not addressed in **FRSA/TRI April 2012 (04-12)** and are used in foam-on or mortar-set tile applications. Maximum Design Pressure is the result of testing for wind load resistance based on allowable wind loads, and reflects the ultimate passing pressure divided by 2 (the 2 to 1 margin of safety per **FBC 1504.9** has already been applied). Refer to **FRSA/TRI April 2012 (04-12), Appendix A, Table 1A** or **FBC 1609** for determination of design wind loads.

#1 Maximum Design Pressure = -240 psf:

Deck: Structural concrete to meet project requirements to satisfaction of AHJ.
 Primer: FlintPrime or ASTM D41.
 Base Sheet: Black Diamond Base Sheet or Flintlastic Ultra Glass SA, self-adhered.
 Underlayment: Flintlastic GTA, torch-applied or Flintlastic GMS, applied in hot asphalt.

#2 Maximum Design Pressure = -555 psf:

Deck: Structural concrete to meet project requirements to satisfaction of AHJ.
 Primer: FlintPrime, FlintPrime SA or ASTM D41.
 Base: (Optional) Flintlastic SA PlyBase or Flintlastic SA Mid Ply, self-adhered.
 Underlayment: Flintlastic SA Cap, self-adhered.

- #3 Maximum Design Pressure = -105.0 psf:**
 Deck: Min. 15/32-inch plywood to meet project requirements to satisfaction of AHJ.
 Primer: (Optional) FlintPrime, FlintPrime SA or ASTM D41
 Base Ply: (Optional) Flintlastic SA PlyBase or Flintlastic SA Mid Ply, self-adhered.
 Underlayment: Flintlastic SA Cap, self-adhered.
- #4 Maximum Design Pressure = -127.5 psf:**
 Deck: Min. 19/32-inch plywood to meet project requirements to satisfaction of AHJ.
 Primer: FlintPrime, FlintPrime SA or ASTM D41
 Joints: Min. 4-inch wide strips of Flintlastic SA PlyBase, self-adhered over all plywood joints.
 Base Ply: (Optional) Flintlastic SA PlyBase or Flintlastic SA Mid Ply, self-adhered.
 Underlayment: Flintlastic SA Cap, self-adhered.
- #5 Maximum Design Pressure = -37.5 psf:**
 Deck: Min. 15/32-inch plywood to meet project requirements to satisfaction of AHJ.
 Base Sheet: ASTM D226, Type II felt or Flintlastic SA NailBase
 Fasteners: 12 ga., 1¼-inch long galvanized ring shank nails through 32 ga., 1 5/8-inch diameter tin caps
 Spacing: 6-inch o.c. at the 4-inch laps and 12-inch o.c. at two (2) equally spaced, staggered rows in the field of the sheet.
 Base Ply: (Optional) Flintlastic SA PlyBase or Flintlastic SA Mid Ply, self-adhered.
 Underlayment: Flintlastic SA Cap, self-adhered.
- #6 Maximum Design Pressure = -45.0 psf*:**
 Deck: Min. 15/32-inch plywood to meet project requirements to satisfaction of AHJ.
 Base Sheet: Glasbase Base Sheet; Flexiglas Base Sheet; Flintlastic Base 20; All Weather / Empire Base Sheet; Flintlastic Poly SMS Base; Flintlastic Ultra Poly SMS Base or Yosemite Venting Base Sheet
 Fasteners: Simplex MAXX Cap Fasteners
 Spacing: 9-inch o.c. at the 2-inch wide side laps and 18-inch o.c. at two (2) equally spaced, staggered center rows.
 Underlayment: Flintlastic GMS, applied in hot asphalt or Flintlastic GTA, torch-applied.
- #7 Maximum Design Pressure = -52.5 psf:**
 Deck: Min. 15/32-inch plywood to meet project requirements to satisfaction of AHJ.
 Base Sheet: Glasbase Base Sheet; Flexiglas Base Sheet; Flintlastic Base 20; All Weather / Empire Base Sheet; Flintlastic Poly SMS Base; Flintlastic Ultra Poly SMS Base or Yosemite Venting Base Sheet
 Fasteners: Simplex MAXX Cap Fasteners
 Spacing: 9-inch o.c. at the 2-inch wide side laps and 12-inch o.c. at two (2) equally spaced, staggered center rows.
 Underlayment: Flintlastic GMS, applied in hot asphalt or Flintlastic GTA, torch-applied.
- #8 Maximum Design Pressure = -52.5 psf:**
 Deck: Min. 15/32-inch plywood to meet project requirements to satisfaction of AHJ.
 Base Sheet: Flintlastic SA NailBase
 Fasteners: Min. 1-inch long, 12 ga. Simplex Metal Cap Nails
 Spacing: 6-inch o.c. at the min. 2-inch laps and 6-inch o.c. at four (4) equally spaced, staggered rows in the field of the sheet.
 Base Ply: (Optional) Flintlastic SA PlyBase or Flintlastic SA Mid Ply, self-adhered.
 Underlayment: Flintlastic SA Cap, self-adhered.
- #9 Maximum Design Pressure = -60.0 psf:**
 Deck: Min. 19/32-inch plywood to meet project requirements to satisfaction of AHJ.
 Base Sheet: Flintlastic SA NailBase
 Fasteners: 12 ga., 1¼-inch long galvanized ring shank nails through 32 ga., 1 5/8-inch diameter tin caps
 Spacing: 8-inch o.c. at the min. 2-inch laps and 8-inch o.c. at three (3) equally spaced, staggered rows in the field of the sheet.
 Base Ply: (Optional) Flintlastic SA PlyBase or Flintlastic SA Mid Ply, self-adhered.
 Underlayment: Flintlastic SA Cap, self-adhered.



- #10 **Maximum Design Pressure = -67.5 psf:**
Deck: Min. 15/32-inch plywood to meet project requirements to satisfaction of AHJ.
Base Sheet: Glasbase Base Sheet; Flexiglas Base Sheet; Flintlastic Base 20; All Weather / Empire Base Sheet; Flintlastic Poly SMS Base; Flintlastic Ultra Poly SMS Base or Yosemite Venting Base Sheet
Fasteners: Cap nails: 1-inch diameter, 0.032-inch thick metal cap with 0.120-inch shank diameter, annular ring shank nails
Spacing: 6-inch o.c. at 4-inch lap and 6-inch o.c. at five (5) equally spaced, staggered center rows in the field of the sheet.
Underlayment: Flintlastic GMS, applied in hot asphalt.
- #11 **Maximum Design Pressure = -75.0 psf:**
Deck: Min. 19/32-inch plywood to meet project requirements to satisfaction of AHJ.
Base Sheet: Flintlastic SA NailBase
Fasteners: 12 ga., 1¼-inch long galvanized ring shank nails through 32 ga., 1 5/8-inch diameter tin caps
Spacing: 6-inch o.c. at the min. 2-inch laps and 6-inch o.c. at four (4) equally spaced, staggered rows in the field of the sheet.
Base Ply: (Optional) Flintlastic SA PlyBase or Flintlastic SA Mid Ply, self-adhered.
Underlayment: Flintlastic SA Cap, self-adhered.
- #12 **Maximum Design Pressure = -90.0 psf:**
Deck: Min. 15/32-inch plywood to meet project requirements to satisfaction of AHJ.
Base Sheet: Glasbase Base Sheet; Flexiglas Base Sheet; Flintlastic Base 20; All Weather / Empire Base Sheet; Flintlastic Poly SMS Base; Flintlastic Ultra Poly SMS Base or Yosemite Venting Base Sheet
Fasteners: Simplex MAXX Cap Fasteners
Spacing: 6-inch o.c. at the 2-inch wide side laps and 6-inch o.c. at two (2) equally spaced, staggered center rows.
Underlayment: Flintlastic GMS, applied in hot asphalt or Flintlastic GTA, torch-applied.
- #14 **Maximum Design Pressure = -105.0 psf:**
Deck: Min. 15/32-inch plywood to meet project requirements to satisfaction of AHJ.
Base Sheet: Glasbase Base Sheet; Flexiglas Base Sheet; Flintlastic Base 20; All Weather / Empire Base Sheet; Flintlastic Poly SMS Base; Flintlastic Ultra Poly SMS Base or Yosemite Venting Base Sheet
Fasteners: Simplex MAXX Cap Fasteners
Spacing: 6-inch o.c. at the 2-inch wide side laps and 6-inch o.c. at three (3) equally spaced, staggered center rows.
Underlayment: Flintlastic GMS, applied in hot asphalt or Flintlastic GTA, torch-applied.
- #15 **Maximum Design Pressure = -105.0 psf:**
Deck: Min. 19/32-inch plywood to meet project requirements to satisfaction of AHJ.
Base Sheet: Flintlastic SA NailBase
Fasteners: 12 ga., 1¼-inch long galvanized ring shank nails through 32 ga., 1 5/8-inch diameter tin caps
Spacing: 4-inch o.c. at the min. 2-inch laps and 4-inch o.c. at four (4) equally spaced, staggered rows in the field of the sheet.
Base Ply: (Optional) Flintlastic SA PlyBase or Flintlastic SA Mid Ply, self-adhered.
Underlayment: Flintlastic SA Cap, self-adhered.
- 5.6.3.1 All other direct-deck, adhered CertainTeed underlayment systems beneath foam-on or mortar-set tile systems carry a Maximum Design Pressure of -45 psf.
- 5.6.3.2 For mechanically attached Base Sheet, the maximum design pressure for the selected assembly shall meet or exceed that required under FRSA/TRI April 2012 (04-12), Appendix A, Table 1A. Alternatively, the maximum design pressure for the selected assembly shall meet or exceed the Zone 1 design pressure determined in accordance with FBC 1609. In this case, Zones 2 and 3 shall employ an attachment density designed by a qualified design professional to resist the elevated pressure criteria. Commonly used methods are ANSI/SPRI WD1, FM Loss Prevention Data Sheet 1-29 and Roofing Application Standard RAS 117. Assemblies marked with an asterisk* carry the limitations set forth in Section 2.2.10.1 of FM Loss Prevention Data Sheet 1-29 (January 2016) for Zone 2/3 enhancements.

5.7 **Exposure Limitations:**

Roofers' Select shall not be left exposed for longer than 30-days after installation. Refer to installation instructions specific to anticipated exposure in Section 6.

Black Diamond Base, WinterGuard HT, WinterGuard Sand, WinterGuard Granular or MetaLayment shall not be left exposed for longer than 180-days after installation.

Flintlastic SA Cap, Flintlastic SA Cap FR, Flintlastic GTA or Flintlastic GMS do not have an exposure limitation, unless the prepared roof covering is to be adhesive-set tile atop Flintlastic SA Cap, GTA or GMS, in which case the maximum exposure is 180 days.

Flintlastic SA NailBase, Flintlastic SA PlyBase, Flintlastic SA Mid Ply and Flintlastic Ultra Glass SA, for use as a base-layer in a multi-ply underlayment system, shall not be left exposed for longer than 30-days after installation, prior to placement of subsequent underlayment layer.

5.8 **Tile Slippage Limitations (per FRSA/TRI April 2012 (04-12)):**

When loading roof tiles on the underlayment in direct-deck tile assemblies, the maximum roof slope shall be as follows. These slope limitations can only be exceeded by using battens during loading of the roof tiles.

TABLE 2: TILE SLIPPAGE LIMITATIONS FOR DIRECT-DECK TILE INSTALLATIONS			
Underlayment	Tile Profile	Staging Method	Maximum Slope
Flintlastic GMS	All	Max. 10-tile stack	4:12
Flintlastic GTA	All	Max. 10-tile stack	6:12
Flintlastic SA Cap	Flat	Max. 6-tile stack (4 over 2)	6:12
	Lugged	Max. 6-tile stack (4 over 2)	5:12

6. INSTALLATION:

6.1 **CertainTeed Roof Underlayments** shall be installed in accordance with **CertainTeed** published installation requirements subject to the Limitations set forth in Section 5 herein and the specifics noted below.

6.2 Re-fasten any loose decking panels, and check for protruding nail heads. Sweep the substrate thoroughly to remove any dust and debris prior to application, and primed the substrate (if applicable).

6.3 Flintlastic SA NailBase, Flintlastic SA PlyBase, Flintlastic SA Mid Ply or Flintlastic Ultra Glass SA:

6.3.1 **Flintlastic SA NailBase, Flintlastic SA PlyBase and Flintlastic SA Mid Ply** are limited to use as a base or mid-layer in multi-ply underlayment systems beneath **Flintlastic SA Cap** or **Flintlastic SA Cap FR**.

6.3.2 **Flintlastic Ultra Glass SA** is limited to use as a base-layer in multi-ply underlayment systems beneath **Flintlastic GTA** or **Flintlastic GMS**.

6.3.3 Install the base-layer underlayment to the substrates detailed in **Section 5.6** in accordance with **CertainTeed** published installation instructions, followed by the final underlayment layer in accordance with the instructions outlined below for the particular top-layer underlayment.

6.3.4 Roof cover limitations are those are those associated with the top-layer underlayment, as set forth in **Table 1**.



- 6.4 Black Diamond Base, Flintlastic SA Cap or SA Cap FR, WinterGuard or MetaLayment:**
- 6.4.1 Shall be installed in compliance with current **CertainTeed** published installation requirements and **FBC 1507** for the type of prepared roof covering to be installed.
 - 6.4.2 Non-Tile Applications:
Shall be fully self-adhered to the substrates noted in **Section 5.6**. Side laps shall be minimum 4-inch and end-laps minimum 6-inch wide, pressed firmly with a seam-roller, and offset end-laps minimum 2 feet from course to course.
Consult **CertainTeed** instructions for use of **FlintBond SBS Modified Bitumen Adhesive**, trowel grade, on the 6-inch end laps and T-seam detailing.
Consult **CertainTeed** instructions regarding back-nailing requirements.
 - 6.4.3 Tile Applications (Flintlastic SA Cap only):
Reference is made to **FRSA/TRI April 2012 (04-12)** Installation Manual and **Table 1** herein.
For mechanically fastened tile roofing over 2-ply system, consisting of Base Sheet and self-adhering top sheet(s), Base Sheet fastening shall be not less than **FRSA/TRI April 2012 (04-12), Table 1**.
For adhesive-set tile applications, refer to **Section 5.6.3** herein.
- 6.5 Flintlastic GTA:**
- 6.5.1 **Flintlastic GTA** shall be installed in compliance with current **CertainTeed** published installation requirements. For use in tile applications, **Flintlastic GTA** is for use as an alternate to the Heat Applied "Cap Sheet" in the "Two Ply System" from **FRSA/TRI April 2012 (04-12)** beneath mechanically fastened or adhered tile roof systems (Base Sheet Limited per 5.6.2)
 - 6.5.2 **Flintlastic GTA** shall be fully torch applied to the substrates noted in Section 5.6. Side (horizontal) laps shall be minimum 3-inch and end (vertical) laps minimum 6-inch wide, and offset end-laps minimum 3 feet from course to course. Side and end-laps shall be fully heat-welded and inspected to ensure minimum 3/8-inch flow of modified compound beyond the lap edge.
 - 6.5.3 Consult CertainTeed instructions regarding back-nailing requirements.
- 6.6 Flintlastic GMS:**
- 6.6.1 **Flintlastic GMS** shall be installed in compliance with current **CertainTeed** published installation requirements. For use in tile applications, **Flintlastic GMS** is for use as an alternate to "Mineral Surface Roll Roofing" (ASTM D6380, Class M) in the "Single Ply System" from **FRSA/TRI April 2012 (04-12)** beneath mechanically fastened tile roof systems or the Hot Asphalt applied "Cap Sheet" in the "Two Ply System" from **FRSA/TRI April 2012 (04-12)** beneath mechanically fastened or adhered tile roof systems.
 - 6.6.2 **Flintlastic GMS** shall be fully asphalt-applied to the substrates noted in Section 5.6. Side (horizontal) laps shall be minimum 3-inch and end (vertical) laps minimum 6-inch wide, and offset end-laps minimum 3 feet from course to course. Side and end-laps shall be fully adhered in a complete mopping of hot asphalt with asphalt extending approximately 3/8-inch beyond the lap edge.
 - 6.6.3 Consult CertainTeed instructions regarding back-nailing requirements.



6.7 Roofers' Select:

- 6.7.1 **Standard-Slope Application (4:12 and greater):** Starting at the lower edge of the roof, apply a single layer of Roofers' Select parallel to the eaves, overhanging drip edge by ½-inch. Overlap ends (vertical laps) at least 4-inch and sides (horizontal laps) at least 2-inch. Offset end laps from course to course at least 6-feet. Apply flat and unwrinkled, fastening as required to hold in place.
- 6.7.2 **Low Slope Application (2:12 up to 4:12):** Starting at the lower edge of the roof, cover the entire deck by applying a double layer of Roofers' Select parallel to the eaves. Begin by applying a 19-inch wide starter strip of Roofers' Select along the eaves, overlapping the drip edge by ½-inch. Place a full-width sheet over the starter, with lower edge flush to the starter's lower edge. Apply succeeding 36-inch wide courses up the roof slope, overlapping the previous course by 19-inch in "shingle-fashion". Overlap ends at least 12-inch. Offset end laps from course to course at least 6-feet. Apply flat and unwrinkled, fastening as required to hold in place.
- 6.7.3 **Eaves Flashing for Ice Dam Protection (all slopes):** Eaves flashing may be constructed from self-adhering waterproofing underlayment holding Florida Product Approval, or by applying a double layer of Roofers' Select cemented together with asphalt roofing cement (ASTM D 4586, Type II). Eaves flashing should be installed to a level of at least 24-inch inside the interior wall line, or in areas of severe icing, at least up to the highest water level expected to occur from ice dams to the satisfaction of the Authority Having Jurisdiction (AHJ).

6.8 Tile Staging (Flintlastic SA Cap, Flintlastic GTA or Flintlastic GMS):

- 6.8.1 Tile shall be loaded and staged in a manner that prevents tile slippage and/or damage to the underlayment. Refer to **Table 2** herein, and CertainTeed published requirements for tile staging.
- 6.8.2 Battens and/or Counter-battens, as required by the tile manufacturer and **FRSA/TRI April 2012 (04-12)** must be used on all roof slopes greater than 7:12. Precautions should be taken as needed, such as the use of battens or nail-boards, to prevent tile sliding and/or damage to the underlayment during the loading process.

7. BUILDING PERMIT REQUIREMENTS:

As required by the Building Official or Authority Having Jurisdiction (AHJ) in order to properly evaluate the installation of this product.

8. MANUFACTURING PLANTS:

Contact the noted QA agency for information on product locations covered for **F.A.C. 61G20-3** QA requirements. The following plants have qualified products under their respective physical properties specifications.

Plant	Specification	Product(s)
Little Rock, AR	ASTM D1970	WinterGuard HT, MetaLayment, Flintlastic SA PlyBase
	ASTM D4601	Flintlastic SA NailBase
	ASTM D6163	Flintlastic SA Mid Ply, Flintlastic Ultra Glass SA, Flintlastic SA Cap FR
	ASTM D6164	Flintlastic GMS
	ASTM D1970, ASTM D6164 & FRSA/TRI April 2012	Flintlastic SA Cap
	ASTM D6222	Flintlastic GTA
Shakopee, MN	ASTM D1970	WinterGuard Sand, WinterGuard Granular, Black Diamond Base Sheet,
Shreveport, LA	ASTM D6757	Roofers' Select

9. QUALITY ASSURANCE ENTITY:

UL, LLC. – QUA9625; (414) 248-6409; karen.buchmann@ul.com

- END OF EVALUATION REPORT -



DEPARTMENT OF BUSINESS AND PROFESSIONAL REGULATION
CONSTRUCTION INDUSTRY LICENSING BOARD
 1940 NORTH MONROE STREET
 TALLAHASSEE FL 32399-0783

(850) 487-1395

SCOTT, RONALD BRICE
 RBS CONSTRUCTION LLC
 4872 BRIGHTMOUR CIRCLE
 ORLANDO FL 32837

Congratulations! With this license you become one of the nearly one million Floridians licensed by the Department of Business and Professional Regulation. Our professionals and businesses range from architects to yacht brokers, from boxers to barbeque restaurants, and they keep Florida's economy strong.

Every day we work to improve the way we do business in order to serve you better. For information about our services, please log onto www.myfloridalicense.com. There you can find more information about our divisions and the regulations that impact you, subscribe to department newsletters and learn more about the Department's initiatives.

Our mission at the Department is: License Efficiently. Regulate Fairly. We constantly strive to serve you better so that you can serve your customers. Thank you for doing business in Florida, and congratulations on your new license!

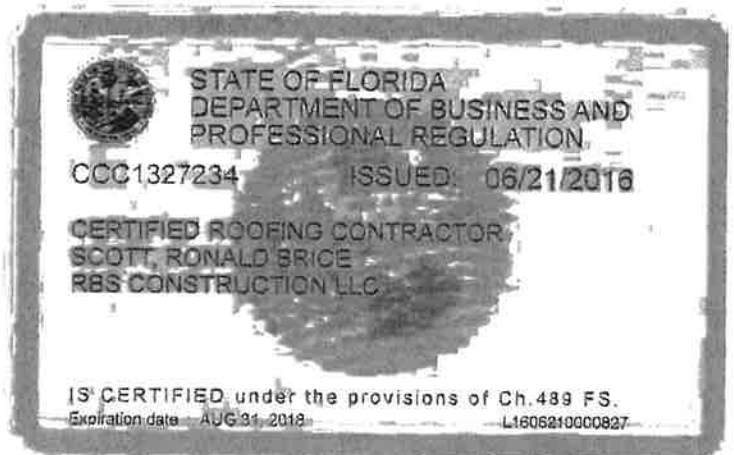

DETACH HERE

RICK SCOTT, GOVERNOR

KEN LAWSON, SECRETARY

STATE OF FLORIDA
 DEPARTMENT OF BUSINESS AND PROFESSIONAL REGULATION
 CONSTRUCTION INDUSTRY LICENSING BOARD

LICENSE NUMBER

CCC1327234

The ROOFING CONTRACTOR
 Named below IS CERTIFIED
 Under the provisions of Chapter 489 FS.
 Expiration date: AUG 31, 2018

SCOTT, RONALD BRICE
 RBS CONSTRUCTION LLC
 4872 BRIGHTMOUR CIRCLE
 ORLANDO FL 32837



2017 EXPIRES 9/30/2018 5000-1058709
6000 BUSINESS OFFICE \$30.00 1 EMPLOYEE 1806 CERTIFIED ROOFING CO \$30.00 1 EMPLOYEE

TOTAL TAX \$60.00
PREVIOUSLY PAID \$60.00
TOTAL DUE \$0.00

SCOTT RONALD BRICE

RBS CONSTRUCTION LLC
SCOTT RONALD BRICE
5205 S ORANGE AVE STE 102
ORLANDO FL 32837

5205 S ORANGE AVE #102 (MOBILE)
N - EDGEWOOD, 32809

PAID: \$60.00 0099-00774096 7/10/2017

Scott Randolph, Tax Collector Local Business Tax Receipt Orange County, Florida

This local business tax receipt is in addition to and not in lieu of any other tax required by law or municipal ordinance. Businesses are subject to regulation of zoning, health and fire authorities. This receipt is valid from October 1 through September 30 of receipt year. Delinquent penalty is added October 1.

2017 EXPIRES 9/30/2018 5000-1058709
5000 BUSINESS OFFICE \$30.00 1 EMPLOYEE 1806 CERTIFIED ROOFING CO \$30.00 1 EMPLOYEE

TOTAL TAX \$60.00
PREVIOUSLY PAID \$60.00
TOTAL DUE \$0.00

SCOTT RONALD BRICE

RBS CONSTRUCTION LLC
SCOTT RONALD BRICE
5205 S ORANGE AVE STE 102
ORLANDO FL 32837

5205 S ORANGE AVE #102 (MOBILE)
N - EDGEWOOD 32809

PAID: \$60.00 0099-00774096 7/10/2017



This receipt is official when validated by the Tax Collector.

RONALD SCOTT BRICE
(407)859-8163

CITY OF EDGEWOOD
LOCAL BUSINESS TAX RECEIPT

405 LARUE AVENUE, EDGEWOOD FL 32809-3406
LICENSE YEAR: OCT 1, 2017 - SEPT 30, 2018

No: 1845
Date: 7/06/17

Address: 5205 S. ORANGE AVE STE102
EDGEWOOD FL 32809
Activity: CONSTRUCTION OFFICE - ADMIN ONLY
CONSTRUCTION OFFICE - ADMIN ONLY

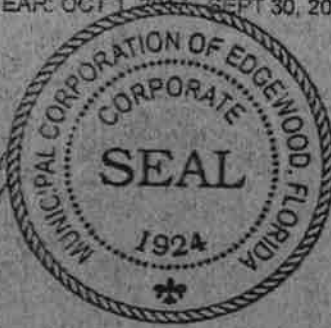

BUS TAX 98.12
PENALTY
TRANSFER

Issued to: RBS CONSTRUCTION LLC
RONALD SCOTT BRICE
5205 S. ORANGE AVE STE102
ORLANDO, FL 32809

Total Paid 98.12
October 1 0.00
November 1 0.00
December 1 0.00
January 1 0.00

Bea L. Meeks

Bea L. Meeks, CBTO, City Clerk

A

MUST BE POSTED CONSPICUOUSLY AT PLACE OF BUSINESS