



City of Belle Isle Job Site Card ROOFING PERMIT 2018-08-071

PERMIT MUST BE POSTED ON SITE - A permit expires in 6 months if approved inspections are not recorded /scheduled within that time frame. You are responsible for scheduling and keeping track of all your inspections -

Permit Number: 2018-08—071

Issue Date: 8/24/2018

Site Address: 4230 Cranmore Ct 32812

Parcel # 20-23-30-1661-00-710

Class: Residential

Subdivision:

Description of Work: **Roof 4100 SQFT. Asphalt Shingles**

Issued To: Jasper Contractors Inc.

Business Phone: 407 278-7788

Name: Bouchard, Donald

Contractor License: CCC1331153

Payment Date & Method: 8/24 / 2018 Picked up by _____

Visa Master Card Amex Discover Check / Money Order # 1999

"WARNING TO OWNER: YOUR FAILURE TO RECORD A NOTICE OF COMMENCEMENT MAY RESULT IN YOUR PAYING TWICE FOR IMPROVEMENTS TO YOUR PROPERTY. IF YOU INTEND TO OBTAIN FINANCING, CONSULT WITH YOUR LENDER OR AN ATTORNEY BEFORE RECORDING YOUR NOTICE OF COMMENCEMENT."

Schedule Inspections via Email at: BDscheduling@universalengineering.com

SCHEDULE INSPECTIONS BY 3:00 PM CUT OFF TIME

Inspection Results Will Be Sent Out the Following Business Day

ROOF	INSPECTOR	DATE	COMMENTS
New Roofs Only Code 700 Deck Nailing, Dry-In Flashing			
710 In-progress			
720 Final			

Inspection requests are to be emailed to BDscheduling@UniversalEngineering.com; a confirmation email will be sent back to you upon scheduling. **Next-Day Inspection requests must be made by 3:00pm.** Please include the following in your request: Permit #, project address, type of inspection, date of the requested inspection, a contact name & a contact phone number. AM or PM may be requested but cannot be guaranteed.

Universal Engineering Sciences - 3532 Maggie Blvd., Orlando, FL 32811 Tel 407-581-8161 * Fax 407-581-0313 * www.universalengineering.com

RECEIVED
AUG 24 2018



City of Belle Isle

Universal Engineering Sciences 3532 Maggie Blvd., Orlando, FL 32811
Tel 407-581-8161 * Fax 407-581-0313 * www.universalengineering.com

APPLICATION FOR ROOFING PERMIT

WARNING TO OWNER: YOUR FAILURE TO RECORD A NOTICE OF COMMENCEMENT MAY RESULT IN YOUR PAYING TWICE FOR IMPROVEMENTS TO YOUR PROPERTY. A NOTICE OF COMMENCEMENT MUST BE RECORDED AND POSTED ON THE JOB SITE BEFORE THE FIRST INSPECTION. IF YOU INTEND TO OBTAIN FINANCING, CONSULT WITH YOUR LENDER OR AN ATTORNEY BEFORE RECORDING YOUR NOTICE OF COMMENCEMENT.

DATE OF APPLICATION: 08/23/2018

ROOF PERMIT NUMBER 2018-08-071

PLEASE PRINT. The undersigned hereby applies for a permit to make installations as indicated below:

Project Address 4230 Cranmore Ct, Belle Isle, FL 32809 X 32812

Property Owner Allen Gray Phone 407-251-8998

Property Owner's Mailing Address 4230 Cranmore Ct City Belle Isle

State FL Zip Code 32812 Parcel Id Number: 20-23-30-1661-00-710

REQUIRED! To obtain this information, please visit http://www.ocpafl.org/Searches/ParcelSearch.aspx

Class of Building: Old New Type of Building: Residential Commercial Other
Type of Work: New Roof ReRoof

REQUIRED! Florida Product Approval Form - NOTE: installation instructions must be posted on-site before your first inspection!

Please indicate the nature of work by completing the information below:

Roof Square Footage: 4100 Number of Stories: 1 Job Valuation: \$ 24,400.00
Type: Asphalt Shingles Metal Modified Bitumen Other: Re-Roofing, Owens Corning FI 10674-R13, Rhino FI 15216 Techwrap FI 17194, 41 sq, 6/12 pitch, Oakridge, Estate Grey

I hereby certify that the above is true and correct to the best of my knowledge and make Application for Permit as outlined above, and if same is granted I agree to conform to all Florida Building Code Regulations and City Ordinances regulating same and in accordance with plans submitted. The issuance of this permit does not grant permission to violate any applicable Town and/or State of Florida codes and/or ordinances. By signing below, I recognize Republic Services is by legal contract the sole authorized provider of garbage, recycling, yard waste, and commercial garbage and construction debris collection and disposal services with the city limits of the City. Contractors, homeowners and commercial businesses may contact Republic Services at 407-293-8000 to setup accounts for Commercial, Construction Roll Off, or other services needed. Rates are fixed by contract and are available at City Hall or from Republic Services. The City enforces the contract through its code enforcement office. Failure to comply will result in a stop work order.

LICENSE HOLDER SIGNATURE [Signature] LICENSE # CCC1331153

LICENSE HOLDER NAME Donald Bouchard COMPANY NAME Jasper Contractors

Street Address 515 18th St

City Orlando State FL Zip Code 32805 Phone Number 407-278-7788

Email Address

Zoning Fee	\$ 30.00
Building Fee	\$ 145.00
Review Fee	\$ -
1% BCAIB Fee	\$ 2.00
1.5% DCA Fee	\$ 2.18
Total Permit Fee	\$ 179.18

Building Official: SM Date 8-24-18
Verified Contractor's Licenses & Insurance are on file Date 8-24-2018

✓
✓ POC
✓ NOC

NOTE: The Building Permit Number is required if the Roof Installation is associated with any construction or alteration where a Building Permit has been issued.

151K 25
24x5 100
145

PAID
8-24-2018
VLSA1999

DOC # 20180425575
07/19/2018 07:59 AM Page 1 of 1
Rec Fee: \$10.00
Deed Doc Tax: \$0.00
Mortgage Doc Tax: \$0.00
Intangible Tax: \$0.00
Phil Diamond, Comptroller
Orange County, FL
Ret To: SIMPLIFILE LC

2018-08-071

THIS INSTRUMENT PREPARED BY:
Name: JASPER CONTRACTORS
Address: 4185 S ORLANDO DR
SANFORD, FL 32773

NOTICE OF COMMENCEMENT

0023627

Permit Number: _____
Parcel ID Number: 20-23-30-1461-00-710

The undersigned hereby gives notice that improvement will be made to certain real property, and in accordance with Chapter 713, Florida Statutes, the following information is provided in this Notice of Commencement.

1. DESCRIPTION OF PROPERTY: (Legal description of the property and street address (if available))

Commercial unit 2 40/4 Lot 71

2. GENERAL DESCRIPTION OF IMPROVEMENT:
Re-Roof

3. OWNER INFORMATION OR LESSEE INFORMATION IF THE LESSEE CONTRACTED FOR THE IMPROVEMENT:

Name and address: Allen Gray 4230 Cranmore Ct. Beech Isle 32812

Interest in property: OWNER

Fee Simple Title Holder (if other than owner listed above) Name: _____

Address: _____

4. CONTRACTOR: Name: JASPER CONTRACTORS Phone Number: 407-278-7788
Address: 4185 S Orlando Dr, Sanford, FL 32773

5. SURETY (if applicable, a copy of the payment bond is attached): Name: _____

Address: _____

Amount of Bond: _____

6. LENDER: Name: _____ Phone Number: _____

Address: _____

7. Persons within the State of Florida Designated by Owner upon whom notice or other documents may be served as provided by Section 713.13(1)(a)7, Florida Statutes.

Name: _____ Phone Number: _____

Address: _____

8. In addition, Owner designates _____ of _____
to receive a copy of the Lienor's Notice as provided in Section 713.13(1)(b), Florida Statutes. Phone number: _____

9. Expiration Date of Notice of Commencement (The expiration is 1 year from date of recording unless a different date is specified): _____

WARNING TO OWNER: ANY PAYMENTS MADE BY THE OWNER AFTER THE EXPIRATION OF THE NOTICE OF COMMENCEMENT ARE CONSIDERED IMPROPER PAYMENTS UNDER CHAPTER 713, PART I, SECTION 713.13, FLORIDA STATUTES, AND CAN RESULT IN YOUR PAYING TWICE FOR IMPROVEMENTS TO YOUR PROPERTY. A NOTICE OF COMMENCEMENT MUST BE RECORDED AND POSTED ON THE JOB SITE BEFORE THE FIRST INSPECTION. IF YOU INTEND TO OBTAIN FINANCING, CONSULT WITH YOUR LENDER OR AN ATTORNEY BEFORE COMMENCING WORK OR RECORDING YOUR NOTICE OF COMMENCEMENT.

X Allen Gray + ALLAN GRAY
(Signature of Owner or Lessee, or Owner's authorized Agent/Authorized Officer/Designated Representative) (Print Name and Provide Signatory's Title/Office)

State of FL County of Orange

The foregoing instrument was acknowledged before me this 13 day of July, 2018

by Allen Gray Who is personally known to me OR

who has produced identification: type of identification produced: DL



[Signature]
Notary Signature

State of FLORIDA, County of ORANGE.
Per §668.50, F.S., which defines and permits electronic signatures,
I certify that this is a true copy of the document as reflected in the
Official Records.
PHIL DIAMOND, COUNTY COMPTROLLER



Scanned by CamScanner

By Janellie Rivera at 9:38 am, Jul 19, 2018

Deputy Comptroller

Date



CITY OF BELLE ISLE, FLORIDA
 Universal Engineering Sciences 3532 Maggie Blvd., Orlando, FL 32811
 Tel 407-581-8161 * Fax 407-581-0313 * www.universalengineering.com

POWER OF ATTORNEY

Date: 08/23/18

Permit #: 2018-08-071

I hereby name and appoint Amenda Creplinski of
(print name)
Jasper Contractors to be my lawful attorney-in-fact to act for
(company name)

me and apply to the City of Belle Isle Building Department for a re-roof permit
(type of permit)
 for work to be performed at the following location:

4230 Cranmore Ct., Belle Isle, FL 32809 32812 and
(street address)

to sign my name and do all things necessary to this appointment.

Certified Contractor's Printed Name: Donald Bauchard

License Number: CC1331153

Certified Contractor's Signature: [Signature]

The foregoing instrument was acknowledged before me this 23 days of August of 2018
 by Donald Bauchard who is personally known to me or who produced
D as identification and who did not take an oath.

State of Florida
 County of Orange

[Signature]



Notary Public, Orange County, Florida

(seal)



City of Belle Isle

Universal Engineering Sciences 3532 Maggie Blvd., Orlando, FL 32811
 Tel 407-581-8161 * Fax 407-581-0313 * www.universalengineering.com

Product Approval Form

DATE: 08/23/18 PERMIT # 2018-08-071
 PROJECT ADDRESS 4230 Cranmore Ct., Belle Isle, FL 32809 32812

As required by Florida Statute 553.842 and Florida Administrative Code 9B-72m, please provide the information and approval numbers of the building components listed below if they will be utilized on the building or structure. FL Approved products are listed online at www.floridabuilding.org or can be obtained from the local product supplier. The following information must be turned in with permit application and available onsite for inspections:

• **NOTE: The Installation instructions must be posted on-site before your first inspection!!**

Product Type	Manufacturer	Model/Series	FL Product Approval #	Product Type	Manufacturer	Model/Series	FL Product Approval #
EXTERIOR DOORS				WALL PANELS			
Swinging				Sliding			
Sliding				Soffits			
Sectional/Rollup				Storefront			
Other				Glass Block			
				Other			
WINDOWS				ROOFING PRODUCTS			
Single/Dbf Hung				Asphalt Shingles	<u>DUGNS CORNING</u>	<u>FL 10071/2-13</u>	
Horizontal Slider				Non Struct Metal			
Casement				Roofing Tiles			
Fixed				Single Ply Roof			
Mullion				Underlayment	<u>RHINO</u>	<u>FL 15214</u>	
Skylights				Other			
Other							
STRUCTURAL COMPONENTS				OTHER			
Wood Connectors							
Wood Anchors							
Truss Plates							
Insulation Forms							
Lintels							
Other							

It is the applicant's responsibility to verify that specific products have been installed in accordance with their limitations and with the minimum required design pressures for the structure. Specific compliance will be verified during field inspections.

Applicant Signature Amenda Cepisic

Date 08/23/18



[BCIS Home](#)
[Log In](#)
[User Registration](#)
[Hot Topics](#)
[Submit Surcharge](#)
[Stats & Facts](#)
[Publications](#)
[Contact Us](#)
[BCIS Site Map](#)
[Links](#)
[Search](#)



Product Approval
USER: Public User

[Product Approval Menu](#) > [Product or Application Search](#) > [Application List](#) > **Application Detail**

OFFICE OF THE SECRETARY

FL #	FL10674-R13								
Application Type	Revision								
Code Version	2017								
Application Status	Approved								
Comments									
Archived	<input type="checkbox"/>								
Product Manufacturer	Owens Corning								
Address/Phone/Email	One Owens Corning Parkway Toledo, OH 43659 (740) 404-7829 greg.keeler@owenscorning.com								
Authorized Signature	Greg Keeler greg.keeler@owenscorning.com								
Technical Representative	Mel Sancrant								
Address/Phone/Email	1 Owens Corning PKWY Toledo, OH 43659 (419) 376-8360 mel.sancrant@owenscornig.com								
Quality Assurance Representative									
Address/Phone/Email									
Category	Roofing								
Subcategory	Asphalt Shingles								
Compliance Method	Evaluation Report from a Florida Registered Architect or a Licensed Florida Professional Engineer <input type="checkbox"/> Evaluation Report - Hardcopy Received								
Florida Engineer or Architect Name who developed the Evaluation Report	Robert J.M. Nieminen								
Florida License	PE-59166								
Quality Assurance Entity	UL LLC								
Quality Assurance Contract Expiration Date	05/16/2020								
Validated By	John W. Knezevich, PE <input checked="" type="checkbox"/> Validation Checklist - Hardcopy Received								
Certificate of Independence	FL10674_R13_COI_2017_01_COI_Nieminen.pdf								
Referenced Standard and Year (of Standard)	<table border="0"> <thead> <tr> <th>Standard</th> <th>Year</th> </tr> </thead> <tbody> <tr> <td>ASTM D3161</td> <td>2016</td> </tr> <tr> <td>ASTM D3462</td> <td>2010</td> </tr> <tr> <td>ASTM D7158</td> <td>2011</td> </tr> </tbody> </table>	Standard	Year	ASTM D3161	2016	ASTM D3462	2010	ASTM D7158	2011
Standard	Year								
ASTM D3161	2016								
ASTM D3462	2010								
ASTM D7158	2011								
Equivalence of Product Standards Certified By									
Sections from the Code									
Product Approval Method	Method 1 Option D								
Date Submitted	10/10/2017								

Date Validated 10/11/2017
 Date Pending FBC Approval 10/15/2017
 Date Approved 12/12/2017

Summary of Products

FL #	Model, Number or Name	Description
10674.1	Owens Corning Asphalt Roofing Shingles and Starters	3-tab, 4-tab, 5-tab, laminated, starter and hip & ridge shingles
Limits of Use Approved for use in HVHZ: No Approved for use outside HVHZ: Yes Impact Resistant: N/A Design Pressure: N/A Other: Refer to ER, Section 5.		Installation Instructions FL10674_R13_II_2017_10_FINAL_ER_OC ASPHALT SHINGLES_FL10674-R13.pdf Verified By: Robert J. M. Nieminen PE - 59166 Created by Independent Third Party: Yes Evaluation Reports FL10674_R13_AE_2017_10_FINAL_ER_OC ASPHALT SHINGLES_FL10674-R13.pdf Created by Independent Third Party: Yes

[Back](#) [Next](#)

Contact Us :: [2601 Blair Stone Road, Tallahassee FL 32399 Phone: 850-487-1824](#)

The State of Florida is an AA/EEO employer. [Copyright 2007-2013 State of Florida](#). :: [Privacy Statement](#) :: [Accessibility Statement](#) :: [Refund Statement](#)

Under Florida law, email addresses are public records. If you do not want your e-mail address released in response to a public-records request, do not send electronic mail to this entity. Instead, contact the office by phone or by traditional mail. If you have any questions, please contact 850.487.1395. *Pursuant to Section 455.275 (1), Florida Statutes, effective October 1, 2012, licensees licensed under Chapter 455, F.S. must provide the Department with an email address if they have one. The emails provided may be used for official communication with the licensee. However email addresses are public record. If you do not wish to supply a personal address, please provide the Department with an email address which can be made available to the public. To determine if you are a licensee under Chapter 455, F.S., please click [here](#).



Credit Card
Safe





EXTERIOR RESEARCH & DESIGN, LLC.

Certificate of Authorization #9503
353 CHRISTIAN STREET, UNIT #13
OXFORD, CT 06478
(203) 262-9245

EVALUATION REPORT

Owens Corning
One Owens Corning Parkway
Toledo, OH 43659
(740) 404-7829

Evaluation Report O37940.02.12-R8
FL10674-R13
Date of Issuance: 02/06/2012
Revision 8: 10/09/2017

SCOPE:

This Evaluation Report is issued under **Rule 61G20-3** and the applicable rules and regulations governing the use of construction materials in the State of Florida. The documentation submitted has been reviewed by Robert Nieminen, P.E. for use of the product under the Florida Building Code and Florida Building Code, Residential Volume. The products described herein have been evaluated for compliance with the **6th Edition (2017) Florida Building Code** sections noted herein.

DESCRIPTION: Owens Corning Asphalt Roof Shingles

LABELING: Labeling shall be in accordance with the requirements the Accredited Quality Assurance Agency noted herein and **FBC 1507.2.7.1 / R905.2.6.1**.

CONTINUED COMPLIANCE: This Evaluation Report is valid until such time as the named product(s) changes, the referenced Quality Assurance documentation changes, or provisions of the Code that relate to the product change. Acceptance of this Evaluation Report by the named client constitutes agreement to notify Robert Nieminen, P.E. if the product changes or the referenced Quality Assurance documentation changes. Trinity|ERD requires a complete review of this Evaluation Report relative to updated Code requirements with each Code Cycle.

ADVERTISEMENT: The Evaluation Report number preceded by the words "Trinity|ERD Evaluated" may be displayed in advertising literature. If any portion of the Evaluation Report is displayed, then it shall be done in its entirety.

INSPECTION: Upon request, a copy of this entire Evaluation Report shall be provided to the user by the manufacturer or its distributors and shall be available for inspection at the job site at the request of the Building Official.

This Evaluation Report consists of pages 1 through 8.

Prepared by:



Robert J.M. Nieminen, P.E.
Florida Registration No. 59166, Florida DCA ANE1983

The facsimile seal appearing was authorized by Robert Nieminen, P.E. on 10/09/2017. This does not serve as an electronically signed document.

CERTIFICATION OF INDEPENDENCE:

1. Trinity|ERD does not have, nor does it intend to acquire or will it acquire, a financial interest in any company manufacturing or distributing products it evaluates.
2. Trinity|ERD is not owned, operated or controlled by any company manufacturing or distributing products it evaluates.
3. Robert Nieminen, P.E. does not have nor will acquire, a financial interest in any company manufacturing or distributing products for which the evaluation reports are being issued.
4. Robert Nieminen, P.E. does not have, nor will acquire, a financial interest in any other entity involved in the approval process of the product.
5. This is a building code evaluation. Neither Trinity|ERD nor Robert Nieminen, P.E. are, in any way, the Designer of Record for any project on which this Evaluation Report, or previous versions thereof, is/was used for permitting or design guidance unless retained specifically for that purpose.

ROOFING SYSTEMS EVALUATION:
1. SCOPE:
Product Category: Roofing

Sub-Category: Asphalt Shingles

Compliance Statement: Owens Corning Asphalt Roof Shingles, as produced by Owens Corning, have demonstrated compliance with the following sections of the 6th Edition (2017) Florida Building Code and Florida Building Code, Residential Volume through testing in accordance with the following Standards. Compliance is subject to the Installation Requirements and Limitations / Conditions of Use set forth herein.

2. STANDARDS:

<u>Section</u>	<u>Property</u>	<u>Standard</u>	<u>Year</u>
1507.2.5, R905.2.4	Physical Properties	ASTM D3462	2010
1507.2.7.1, R905.2.6.1	Wind Resistance	ASTM D3161	2016
1507.2.7.1, R905.2.6.1	Wind Resistance	ASTM D7158	2011

3. REFERENCES:

<u>Entity</u>	<u>Examination</u>	<u>Reference</u>	<u>Date</u>
UL LLC (CER9626)	Physicals & Wind Resistance	File R2453, Vol. 3	02/15/2007
UL LLC (CER9626)	Physicals & Wind Resistance	20120516-R2453	05/16/2012
UL LLC (TST9628)	Physical Properties	06CA20263	04/18/2006
UL LLC (TST9628)	Wind Resistance	11CA34308	02/18/2012
UL LLC (TST9628)	Physicals & Wind Resistance	4786093137	02/01/2014
UL LLC (TST9628)	Wind Resistance	4786126532	02/10/2014
UL LLC (TST9628)	Physical Properties	Classification letter	02/13/2014
UL LLC (TST9628)	Physical Properties	Classification letter	10/02/2015
Miami-Dade (CER1592)	FBC HVHZ Compliance	Various NOAs	Various
UL LLC (QUA9625)	Quality Control	Service Confirmation	Exp. 05/16/2020

4. PRODUCT DESCRIPTION:
4.1 Asphalt Shingles:

 4.1.1 Classic[®] and Supreme[®] are fiberglass reinforced, 3-tab asphalt roof shingles.

 4.1.2 Berkshire[®] are fiberglass reinforced, 4-tab asphalt roof shingles.

 4.1.3 Devonshire[™] are fiberglass reinforced, 5-tab asphalt roof shingles.

 4.1.4 Duration[®], TruDefinition[®] Duration[®], Duration[®] Premium Cool, TruDefinition[®] Duration[®] Designer Color Collection, TruDefinition[®] Oakridge[®], Oakridge[®] and WeatherGuard[®] HP are fiberglass reinforced, laminated asphalt roof shingles.

4.2 Hip & Ridge Shingles:

 4.2.1 Berkshire[®] Hip & Ridge Shingles, High Ridge, WeatherGuard[®] HP Hip & Ridge Shingles, ProEdge Hip & Ridge Shingles and DuraRidge[™] Hip & Ridge Shingles are fiberglass reinforced, hip and ridge asphalt roof shingles.

4.3 Accessory Starter Strips:

4.3.1 Starter Strip Shingle, Starter Strip Plus and Starter Shingle Roll are starter strips for asphalt roof shingles.

5. LIMITATIONS:

5.1 This is a building code evaluation. Neither Trinity|ERD nor Robert Nieminen, P.E. are, in any way, the Designer of Record for any project on which this Evaluation Report, or previous versions thereof, is/was used for permitting or design guidance unless retained specifically for that purpose.

5.2 This Evaluation Report is not for use in FBC HVHZ jurisdictions.

5.3 Fire Classification is not part of this Evaluation Report; refer to current Approved Roofing Materials Directory for fire ratings of this product.

5.4 Wind Classification:

- 5.4.1 All **Owens Corning asphalt shingles** noted herein are Classified in accordance with **FBC Tables 1507.2.7.1** and **R905.2.6.1** to **ASTM D3161, Class F** and/or **ASTM D7158, Class H**, indicating the shingles are acceptable for use in all wind zones up to $V_{asd} = 150$ mph ($V_{ult} = 194$ mph). Refer to Section 6 for installation requirements to meet this wind rating.
- 5.4.2 All **Owens Corning hip & ridge shingles, Starter Strip Shingle** and **Starter Strip Plus** noted herein are Classified in accordance with **FBC Tables 1507.2.7.1** and **R905.2.6.1** to **ASTM D3161, Class F**, indicating the shingles are acceptable for use in all wind zones up to $V_{asd} = 150$ mph ($V_{ult} = 194$ mph). Refer to Section 6 for installation requirements to meet this wind rating.
- 5.4.3 Classification by **ASTM D7158** applies to **exposure category B or C**, as defined in **FBC 1609.4.3**, and a **mean roof height of 60 feet or less**. Calculations by a qualified design professional are required for conditions outside these limitations. Contact the shingle manufacturer for data specific to each shingle.
- 5.4.4 Refer to **Owens Corning** published information on wind resistance and installation limitations.
- 5.5 All products in the roof assembly shall have quality assurance audit in accordance with **F.A.C. Rule 61G20-3**.

6. INSTALLATION:

6.1 Underlayment:

- 6.1.1 Underlayment shall be acceptable to **Owens Corning** and shall hold current Florida Statewide Product Approval, or be Locally Approved per **Rule 61G20-3**, per **FBC 1507.2.3, 1507.2.4** or **R905.2.3**.

6.2 Asphalt Shingles:

- 6.2.1 Installation of asphalt shingles shall comply with the **Owens Corning** current published instructions, using minimum four (4) nails per shingle in accordance with **FBC 1507.2.7** or **R905.2.6**, with the following exceptions:
 - **Berkshire** shingles require minimum five (5) nails per shingle.
 - **WeatherGuard HP** shingles require minimum six (6) nails per shingle.
 - **Devonshire™** shingles require minimum six (6) nails per shingle.
 - **Starter Strip Shingle** and **Starter Strip Plus** require minimum five (5) nails per strip.

Refer to **Owens Corning** published information on wind resistance and installation limitations.

- 6.2.2 Fasteners shall be in accordance with the manufacturer's published requirements, but not less than **FBC 1507.2.6** or **R905.2.5**. Staples are not permitted.
- 6.2.4 Where the roof slope exceeds 21 units vertical in 12 units horizontal, special methods of fastening are required. See figures below for details.
- 6.2.5 Minimum Nailing – **Starter Strip Shingle** and **Starter Strip Plus:**

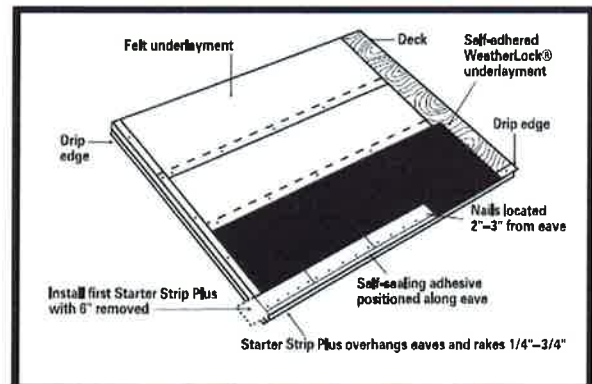
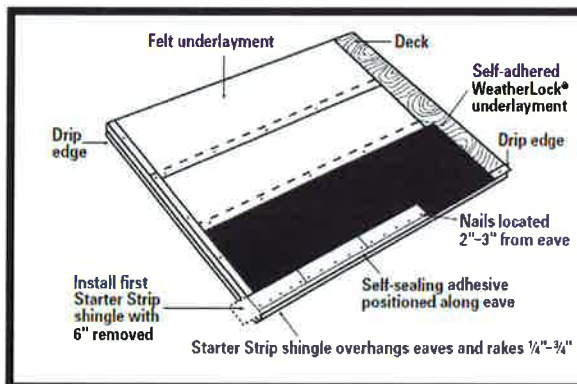

6.2.6 Minimum Nailing – Classic® & Supreme:

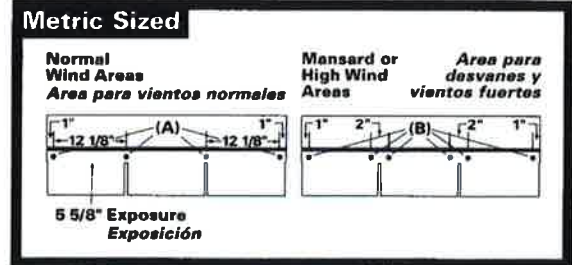
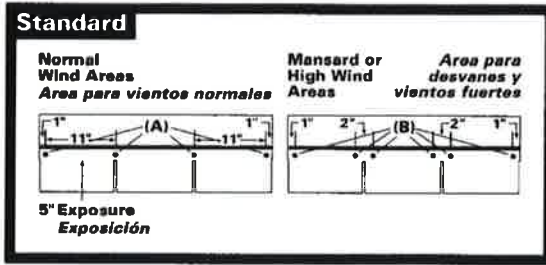

6.2.7 Minimum Nailing – Berkshire®:

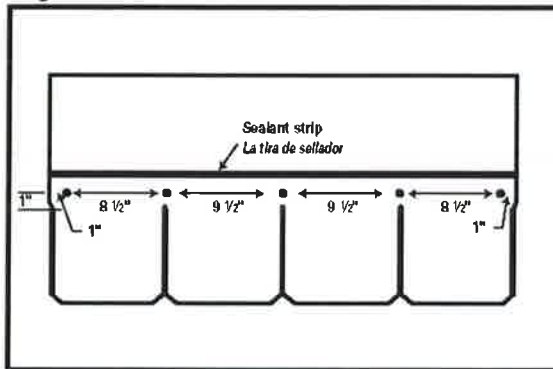

Standard Fastening Pattern

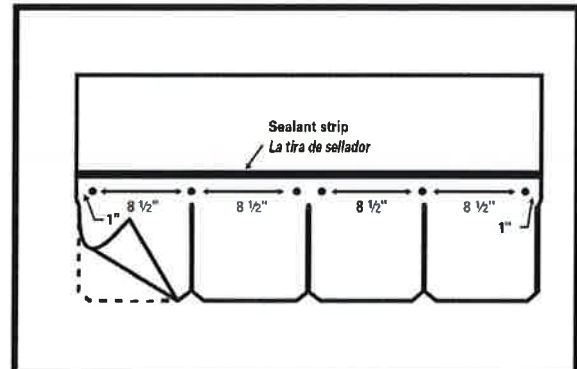

6-Nail Fastening Pattern

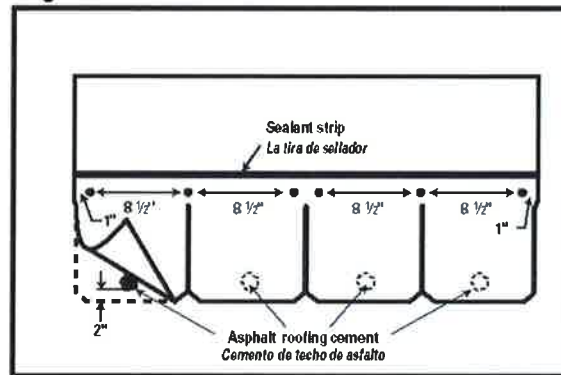

Mansard or Steep Slope Fastening Pattern

6.2.8 Minimum Nailing – Devonshire™:

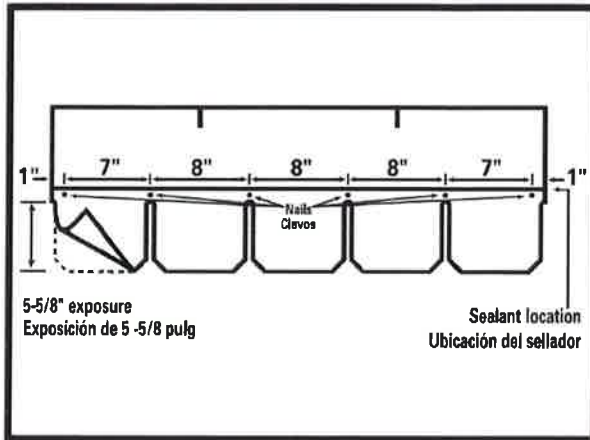

Standard 6-Nail Fastening Pattern

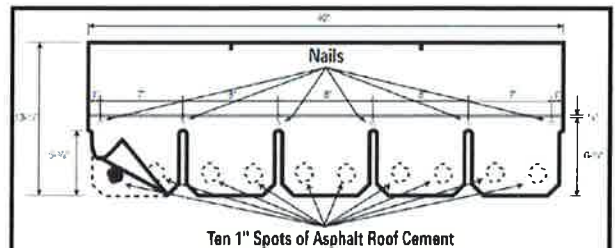

Mansard or Steep Slope Fastening Pattern

6.2.9 Minimum Nailing – Duration®, TruDefinition® Duration, Duration® Premium Cool & TruDefinition® Duration® Designer Color Collection:

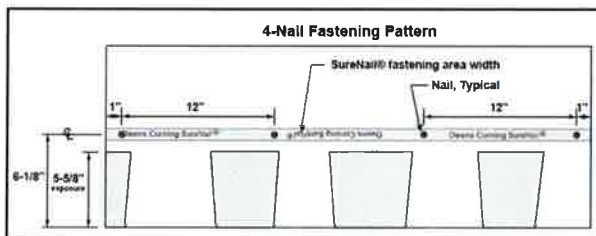

Standard Fastening Pattern

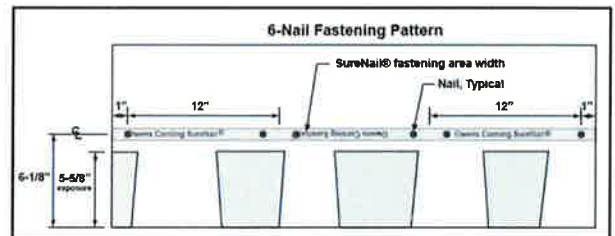

6-Nail Fastening Pattern

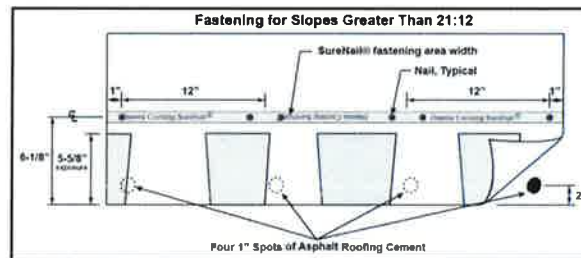

Mansard or Steep Slope Fastening Pattern

6.2.1 Minimum Nailing – TruDefinition® Oakridge®, Oakridge®:

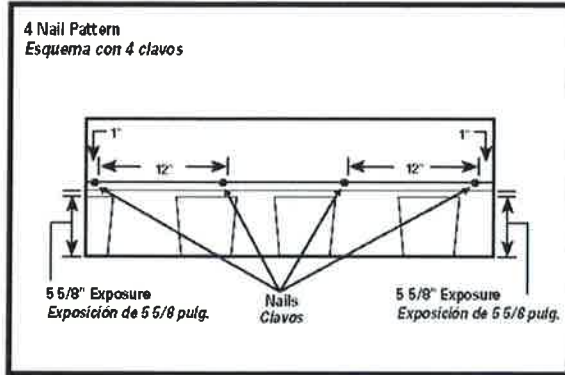

Standard Fastening Pattern

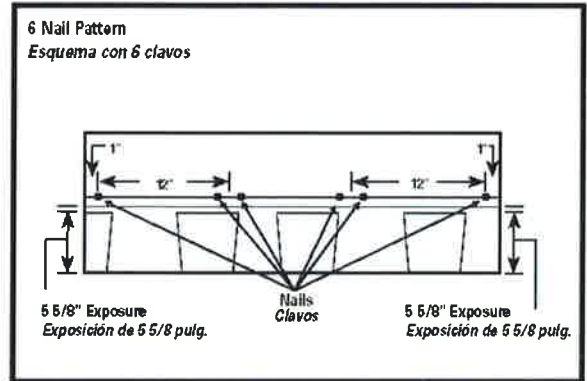

6-Nail Fastening Pattern

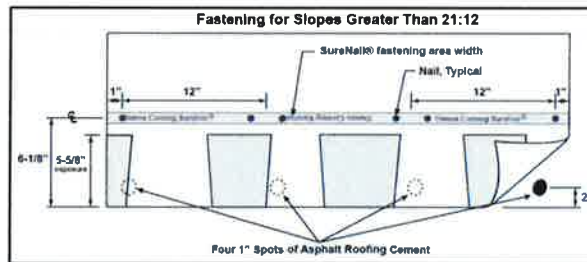

Mansard or Steep Slope Fastening Pattern

6.2.1 Minimum Nailing – WeatherGuard® HP:

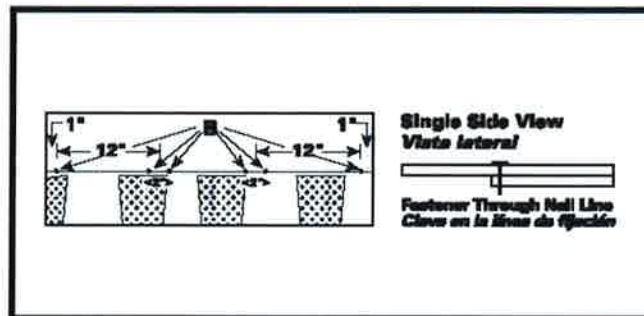

6.3 Hip & Ridge Shingles:

- 6.3.1 Installation of **Berkshire® Hip and Ridge Shingles, High Ridge, WeatherGuard® HP Hip and Ridge Shingles** and **ProEdge Hip & Ridge Shingles** shall comply with the **Owens Corning** current published instructions, using four (4) nails per shingle. Installation of **DuraRidge™ Hip & Ridge Shingles** shall comply with the **Owens Corning** current published instructions, using two (2) nails per shingle. Refer to **Owens Corning** published information on wind resistance and installation limitations, including the use of hand-sealing for wind warranties.
- 6.3.2 Fasteners shall be in accordance with the manufacturer's published requirements, but not less than **FBC 1507.2.6 or R905.2.5**. Staples are not permitted.
- 6.3.3 Minimum Nailing – **Berkshire® Hip & Ridge and High Ridge:**

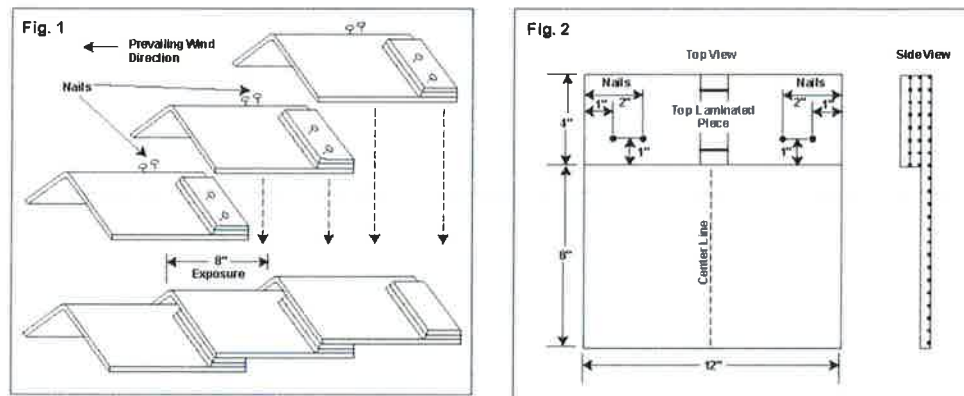

6.3.4 Minimum Nailing – **WeatherGuard® HP Hip and Ridge:**

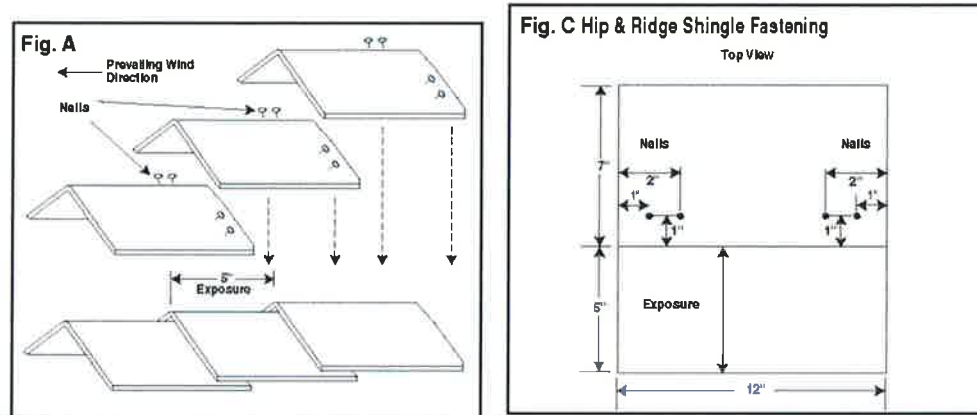

6.3.5 Minimum Nailing - ProEdge Hip & Ridge Shingles:

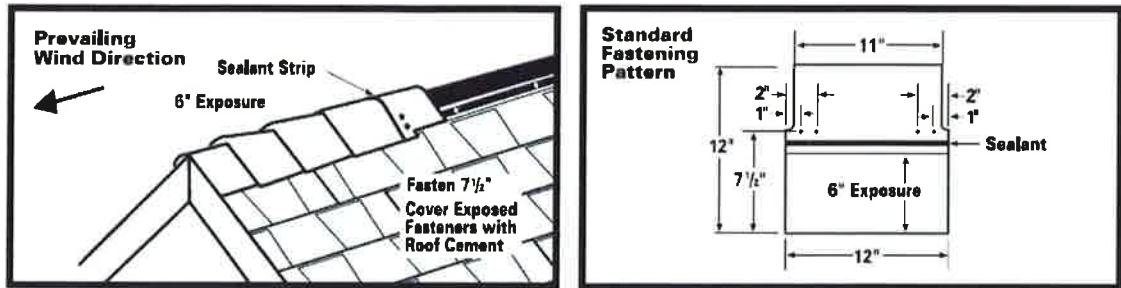

6.3.6 Minimum Nailing – DuraRidge™ Hip & Ridge Shingles:

Note: The drawings below pertain to minimum, as-tested attachment requirements. Refer to Owens Corning published installation instructions for their minimum requirements.

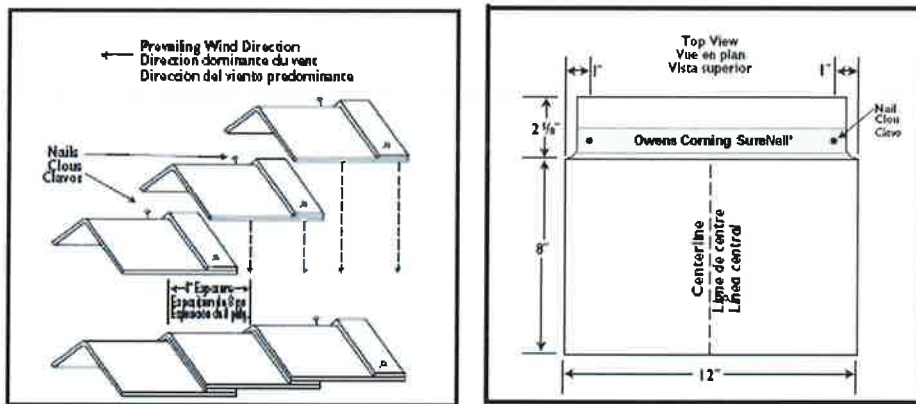

7. LABELING:

- 7.1 Labeling shall be in accordance with the requirements the Accredited Quality Assurance Agency noted herein.
- 7.2 Asphalt shingle wrappers shall indicate compliance with one of the required classifications detailed in FBC Table 1507.2.7.1 / R905.2.6.1.

8. BUILDING PERMIT REQUIREMENTS:

As required by the Building Official or Authority Having Jurisdiction in order to properly evaluate the installation of this product.

9. MANUFACTURING PLANTS:

Contact the named QA entity for information on which plants produce products covered by Florida Rule 9N-3 QA requirements.

10. QUALITY ASSURANCE ENTITY:

UL LLC– QUA9625 ; (631) 546-2458; Kanchi.Agrawala-Dokania@ul.com

- END OF EVALUATION REPORT -



[BCIS Home](#) |
 [Log In](#) |
 [User Registration](#) |
 [Hot Topics](#) |
 [Submit Surcharge](#) |
 [Stats & Facts](#) |
 [Publications](#) |
 [Contact Us](#) |
 [BCIS Site Map](#) |
 [Links](#) |
 [Search](#)



Product Approval
USER: Public User

[Product Approval Menu](#) >
 [Product or Application Search](#) >
 [Application List](#) >
 Application Detail



FL #	FL15216-R4								
Application Type	Revision								
Code Version	2017								
Application Status	Approved								
Comments									
Archived	<input type="checkbox"/>								
Product Manufacturer	Owens Corning Roofing and Asphalt, LLC								
Address/Phone/Email	One Owens Corning Parkway Toledo, OH 43645 (740) 321-6345 Greg.Keeler@owenscorning.com								
Authorized Signature	Keeler Greg Greg.Keeler@owenscorning.com								
Technical Representative	Greg Keeler								
Address/Phone/Email	2790 Columbus Road Granville, OH 43023 (740) 321-6345 greg.keeler@owenscorning.com								
Quality Assurance Representative									
Address/Phone/Email									
Category	Roofing								
Subcategory	Underlayments								
Compliance Method	Evaluation Report from a Florida Registered Architect or a Licensed Florida Professional Engineer <input type="checkbox"/> Evaluation Report - Hardcopy Received								
Florida Engineer or Architect Name who developed the Evaluation Report	Robert Nieminen								
Florida License	PE-59166								
Quality Assurance Entity	Intertek Testing Services NA, Inc. - QA Entity								
Quality Assurance Contract Expiration Date	12/31/2020								
Validated By	John W. Knezevich, PE <input checked="" type="checkbox"/> Validation Checklist - Hardcopy Received								
Certificate of Independence	FL15216 R4 COI 2018 01 COI NIEMINEN.pdf								
Referenced Standard and Year (of Standard)	<table border="0"> <thead> <tr> <th>Standard</th> <th>Year</th> </tr> </thead> <tbody> <tr> <td>ASTM D1970 (tear)</td> <td>2015</td> </tr> <tr> <td>ASTM D226 (physicals)</td> <td>2009</td> </tr> <tr> <td>TAS 117(B)</td> <td>1995</td> </tr> </tbody> </table>	Standard	Year	ASTM D1970 (tear)	2015	ASTM D226 (physicals)	2009	TAS 117(B)	1995
Standard	Year								
ASTM D1970 (tear)	2015								
ASTM D226 (physicals)	2009								
TAS 117(B)	1995								
Equivalence of Product Standards Certified By									
Sections from the Code									
Product Approval Method	Method 1 Option D								
Date Submitted	04/20/2018								

Date Validated 04/20/2018
 Date Pending FBC Approval 04/22/2018
 Date Approved 06/12/2018

Summary of Products

FL #	Model, Number or Name	Description
15216.1	RhinoRoof Underlayments	Synthetic roof underlayments
Limits of Use Approved for use in HVHZ: No Approved for use outside HVHZ: Yes Impact Resistant: N/A Design Pressure: N/A Other: See ER Section 5 for Limits of Use.		Installation Instructions FL15216 R4 II 2018 04 FINAL ER OWENS CORNING RHINOROOF FL15216-R4.pdf Verified By: Robert Nieminen PE-59166 Created by Independent Third Party: Yes Evaluation Reports FL15216 R4 AE 2018 04 FINAL ER OWENS CORNING RHINOROOF FL15216-R4.pdf Created by Independent Third Party: Yes

[Back](#) [Next](#)

Contact Us :: [2601 Blair Stone Road, Tallahassee FL 32399 Phone: 850-487-1824](#)

The State of Florida is an AA/EEO employer. [Copyright 2007-2013 State of Florida](#). :: [Privacy Statement](#) :: [Accessibility Statement](#) :: [Refund Statement](#)

Under Florida law, email addresses are public records. If you do not want your e-mail address released in response to a public-records request, do not send electronic mail to this entity. Instead, contact the office by phone or by traditional mail. If you have any questions, please contact 850.487.1395. *Pursuant to Section 455.275 (1), Florida Statutes, effective October 1, 2012, licensees licensed under Chapter 455, F.S. must provide the Department with an email address if they have one. The emails provided may be used for official communication with the licensee. However email addresses are public record. If you do not wish to supply a personal address, please provide the Department with an email address which can be made available to the public. To determine if you are a licensee under Chapter 455, F.S., please click [here](#).



Credit Card
Safe





NEMO|etc.

Certificate of Authorization #32455
353 Christian Street, Unit #13
Oxford, CT 06478
(203) 262-9245

ENGINEER

EVALUATE

TEST

CONSULT

CERTIFY

EVALUATION REPORT

Owens Corning Roofing and Asphalt, LLC
One Owens Corning Parkway
Toledo, OH 43659
(740) 321-6345

Evaluation Report I40510.02.12-R4
FL15216-R4
Date of Issuance: 02/17/2012
Revision 4: 04/19/2018

SCOPE:

This Evaluation Report is issued under **Rule 61G20-3** and the applicable rules and regulations governing the use of construction materials in the State of Florida. The documentation submitted has been reviewed by Robert Nieminen, P.E. for use of the product under the Florida Building Code and Florida Building Code, Residential Volume. The products described herein have been evaluated for compliance with the **6th Edition (2017) Florida Building Code** sections noted herein.

DESCRIPTION: RhinoRoof Underlayments

LABELING: Labeling shall be in accordance with the requirements of the Accredited Quality Assurance Agency noted herein.

CONTINUED COMPLIANCE: This Evaluation Report is valid until such time as the named product(s) changes, the referenced Quality Assurance documentation changes, or provisions of the Code that relate to the product change. Acceptance of this Evaluation Report by the named client constitutes agreement to notify Robert Nieminen, P.E. of any changes to the product(s), the Quality Assurance or the production facility location(s). NEMO|etc. requires a complete review of this Evaluation Report relative to updated Code requirements with each Code Cycle.

ADVERTISEMENT: The Evaluation Report number preceded by the words "NEMO|etc. Evaluated" may be displayed in advertising literature. If any portion of the Evaluation Report is displayed, then it shall be done in its entirety.

INSPECTION: Upon request, a copy of this entire Evaluation Report shall be provided to the user by the manufacturer or its distributors and shall be available for inspection at the job site at the request of the Building Official.

This Evaluation Report consists of pages 1 through 3.

Prepared by:

Robert J.M. Nieminen, P.E.
Florida Registration No. 59166, Florida DCA ANE1983



The facsimile seal appearing was authorized by Robert Nieminen, P.E. on 04/19/2018. This does not serve as an electronically signed document.

CERTIFICATION OF INDEPENDENCE:

1. NEMO ETC, LLC does not have, nor does it intend to acquire or will it acquire, a financial interest in any company manufacturing or distributing products it evaluates.
2. NEMO ETC, LLC is not owned, operated or controlled by any company manufacturing or distributing products it evaluates.
3. Robert Nieminen, P.E. does not have nor will acquire, a financial interest in any company manufacturing or distributing products for which the evaluation reports are being issued.
4. Robert Nieminen, P.E. does not have, nor will acquire, a financial interest in any other entity involved in the approval process of the product.
5. This is a building code evaluation. Neither NEMO|etc. nor Robert Nieminen, P.E. are, in any way, the Designer of Record for any project on which this Evaluation Report, or previous versions thereof, is/was used for permitting or design guidance unless retained specifically for that purpose.

ROOFING COMPONENT EVALUATION:
1. SCOPE:
Product Category: Roofing

Sub-Category: Underlayment

Compliance Statement: RhinoRoof Underlayments, as produced by Owens Corning Roofing and Asphalt, LLC, has demonstrated compliance with the following sections of the 6th Edition (2017) Florida Building Code through testing in accordance with applicable sections of the following Standards. Compliance is subject to the Installation Requirements and Limitations / Conditions of Use set forth herein.

2. STANDARDS:

<u>Section</u>	<u>Properties</u>	<u>Standard</u>	<u>Year</u>
1507.1.1, R905.1.1 Exception	Unrolling, Breaking Strength, Pliability	ASTM D226	2009
1507.1.1, R905.1.1 Exception	Tear Strength	ASTM D1970	2015
TAS 110	Pull-through resistance	TAS 117(B)	1995

3. REFERENCES:

<u>Entity</u>	<u>Examination</u>	<u>Reference</u>	<u>Date</u>
ITS (TST1509)	Physical Properties	100539395COQ-006	10/27/2011
ITS (TST1509)	Physical Properties	100539395COQ-002	10/27/2011
ITS (TST1509)	Physical Properties	100539395COQ-006	03/14/2014
PRI (TST5878)	ASTM D1970; Tear strength	OCF-330-02-02	10/03/2017
PRI (TST5878)	TAS 117(B); Pull-through	OCF-422-02-01	04/03/2018
ITS (QUA1673)	Quality Control	Service Confirmation	09/30/2017

4. PRODUCT DESCRIPTION:

- 4.1 **RhinoRoof U20** is a multilayered polymer woven coated synthetic roof underlayment available in 42-inch wide rolls, and can be produced in various other sizes; meets FBC 1507.1.1 & R905.1.1 (Exception).

5. LIMITATIONS:

- 5.1 This is a building code evaluation. Neither NEMO ETC, LLC nor Robert Nieminen, P.E. are, in any way, the Designer of Record for any project on which this Evaluation Report, or previous versions thereof, is/was used for permitting or design guidance unless retained specifically for that purpose.
- 5.2 This Evaluation Report is not for use in FBC HVHZ jurisdictions.
- 5.3 Fire Classification is not part of this Evaluation Report; refer to current Approved Roofing Materials Directory or test report from accredited testing agency for fire ratings of this product.
- 5.4 **RhinoRoof Underlayments** may be used with any prepared roof cover where the product is specifically referenced within FBC approval documents. If not listed, a request may be made to the Authority Having Jurisdiction for approval based on this evaluation combined with supporting data for the prepared roof covering.
- 5.5 **Allowable Roof Covers:**

TABLE 1: ROOF COVER OPTIONS						
<u>Underlayment</u>	<u>Asphalt Shingles</u>	<u>Nail-On Tile</u>	<u>Foam-On Tile</u>	<u>Metal</u>	<u>Wood Shakes & Shingles</u>	<u>Slate or Simulated Slate</u>
RhinoRoof U20	Yes	No	No	Yes	Yes	No

5.6 **Exposure Limitations:**

RhinoRoof U20 shall not be left exposed for longer than **30-days** after installation.

6. INSTALLATION:

6.1 **RhinoRoof Underlayments** shall be installed in accordance with **Owens Corning Roofing and Asphalt, LLC** published installation instructions subject to the Limitations set forth in Section 5 herein and the specifics noted below.

6.2 Re-fasten any loose decking panels, and check for protruding nail heads. Sweep the substrate thoroughly to remove any dust and debris prior to application.

6.3 RhinoRoof U20:

6.3.1 Shall be installed in compliance with the requirements for **ASTM D226, Type I or II** underlayment in **FBC Table 1507.1.1 or R905.1.1** for the type of prepared roof covering to be installed, taking into account the wider sheet-width.

6.3.2 Fasteners:

For exposure \leq 24 hours, corrosion resistant fasteners may be 1-inch roofing nails with a 3/8-inch diameter head, minimum 1-inch diameter plastic or metal cap nails or FBC HVHZ nails & 1-5/8" diameter tin caps (with the rough edge facing up). The use of staples is prohibited.

For exposure > 24 hours up to maximum 30 days, corrosion resistant fasteners shall be minimum 1-inch diameter plastic or metal cap nails or FBC HVHZ nails & 1-5/8" diameter tin caps (with the rough edge facing up). The use of staples is prohibited.

6.3.2.1 Code Reference: The Exception statement in FBC 1507.1.1 and FBC R905.1.1 states: *"...except metal cap nails shall be required where the ultimate design wind speed, V_{ult} , equals or exceeds 150 mph."*

Owens Corning Roofing and Asphalt, LLC has furnished data to permit the use of 1-inch diameter plastic cap nails in lieu of metal cap nails for these applications, when the **RhinoRoof U20** underlayment is installed beneath mechanically fastened prepared roof covers referenced in FBC Table 1507.1.1 or R905.1.1.

6.3.3 Single Layer; Roof Slope > 4:12:

End (vertical) laps shall be minimum 6-inches and side (horizontal) laps shall be minimum 4-inches. Refer to Owens Corning Roofing and Asphalt, LLC recommendations for alternate lap configurations and/or the use of sealant under certain conditions.

For exposure \leq 24 hours, use of every-other fastening location printed on the surface is acceptable. For exposure > 24 hours up to maximum 30-days, use of every fastening location printed on the surface is required.

When batten systems are to be installed atop the underlayment, the underlayment need only be preliminarily attached pending attachment of the battens on the same day. Battens shall not be positioned over cap nails. If this occurs, remove the cap nail and patch the hole in accordance with Owens Corning Roofing and Asphalt, LLC published instructions.

6.3.4 Double Layer; 2:12 < Roof Slope < 4:12:

End (vertical) laps shall be minimum 12-inches and side (horizontal) laps shall be minimum half-sheet-width plus 1-inch.

Double layer application; begin by fastening a half-width plus 1-inch starter strip along the eaves. Place a full-width sheet over the starter, completely overlapping the starter course. Continue as noted in 6.3.3, but maintaining minimum half-width plus 1-inch side (horizontal) laps, resulting in a double-layer application.

7. BUILDING PERMIT REQUIREMENTS:

As required by the Building Official or Authority Having Jurisdiction in order to properly evaluate the installation of this product.

8. MANUFACTURING PLANTS:

Qingdao, China

9. QUALITY ASSURANCE ENTITY:

Intertek Testing Services NA Inc. – QUA1673; (608) 836-4400

- END OF EVALUATION REPORT -

CONWAY GROVES HOMEOWNERS ASSOCIATION, INC.
c/o DON ASHER AND ASSOCIATES, INC.
1801 COOK AVENUE
ORLANDO, FL 32808 2913

NOTICE OF APPROVAL

April 30, 2018

ALLAN & MARGARET F R GRAY
4230 CRANMORE COURT
ORLANDO FL 32812

RE: 4230 CRANMORE COURT

Dear ALLAN & MARGARET F R GRAY:

Your request for architectural change has been approved. Specifically, you have approval to proceed with the following:

Architectural approval request/Roof replacement

Architectural Review Application for the replacement of the roof using shingle color Estate Gray has been approved.

We reserve the right to make a final inspection of the change to make sure it matches the request you submitted for approval. Please follow the plan you submitted or submit an additional request form if you cannot follow the original plan.

You must follow all local building codes and setback requirements when making this change. A building permit may be needed. This can be applied for at the county offices.

Our approval here is only based on the aesthetics of your proposed change. This approval should not be taken as any certification as to the construction worthiness or or structural integrity of the change you propose. Be aware that you are responsible for contacting the appropriate utility companies before digging.

We appreciate your cooperation in submitting this request. An attractive community helps all of us get the full value from our homes when we decide to sell.

Sincerely,

Jeff Davis, LCAM

Jeff@donasher.com

Community Association Manager

ARCHITECTURAL REVIEW APPLICATION

CONWAY GROVES HOMEOWNERS ASSOC

c/o Don Asher and Associates
1804 Cook Avenue
Orlando, FL 32808

Phone: (407) 425-4861 Fax: (407) 843-5188

(For Office use only)

Mailing Address: If different from property address _____

Property Description: _____

Street Address: 4230 Cranmore Ct Belle Isle Fl 32812

Name: Allen Gray

Lot # 71

Address: 4230 Cranmore Ct Belle Isle 32812

Owners Name: Allen Gray

Property Address: 4230 Cranmore Ct Belle Isle Fl 32812

Signature: _____

Phone: Day 407-261-8998 Night _____

Note: THIS FORM WILL BE MAILED BACK TO THE PROPERTY OWNER: THE FOLLOWING ITEMS NEED TO BE SUBMITTED, IN DUPLICATE, ALONG WITH THIS FORM: 1.) PLOT PLAN SHOWING LOCATION OF MODIFICATION; 2.) DRAWING AND COLOR SAMPLES, 3.) ONCE ARC IS APPROVED AND DATED, WORK MUST BE COMPLETED WITHIN 90 DAYS OR A NEW APPLICATION MUST BE SUBMITTED.

Please complete the following, if applicable:

Contractor: Jesper Contractors

Architect: _____

Phone: 407-278-7788

Phone: _____

Purpose of Application: Check appropriate items

Re-Roofing, Owens Corning Fl 10674-R13, Rhino Fl 15216,

- Exterior Color Selections (attach color samples; Denote body, trim & roof colors)
- Pool (Detail color of any screen enclosure and detail how pool equipment will be screened from view.)
- Fence Plan (Detail style, material, size and color if the fence will be painted)
- Landscaping Plan
- Construction project such as screen room or room addition. Colors and materials must be detailed.
- Other _____

Notice

"THESE PLANS HAVE BEEN REVIEWED FOR THE LIMITED PURPOSE OF DETERMINING THE AESTHETIC COMPATIBILITY OF THE DESIGN PLANS OF THE COMMUNITY. THESE PLANS ARE REVIEWED ON THAT LIMITED BASIS. NO REVIEW HAS BEEN MADE WITH RESPECT TO THE FUNCTIONABILITY, SAFETY, COMPLIANCE WITH GOVERNMENTAL REGULATIONS, OR OTHERWISE AND NO RELIANCE ON THIS APPROVAL SHOULD BE MADE BY ANY PARTY WITH RESPECT TO ANY SUCH MATTERS. THE UNDERSIGNED EXPRESSLY DISCLAIMS LIABILITY OF ANY KIND WITH RESPECT TO THESE PLANS, THE REVIEW HEREOF, OR ANY STRUCTURES BUILT PURSUANT HERETO, INCLUDING BUT NOT LIMITED TO, LIABILITY FOR NEGLIGENCE OR BREACH OF EXPRESS OR IMPLIED WARRANTY."

Architectural Review Committee

Approved: [Signature] 7/22/18
Signature Date

Comments by ARC: _____

Disapproved: _____
Signature Date

Date received by D.A.: 7/22/18

Date Mailed to mailing address: _____

Date submitted to ARC: 7/22/18

Date mailed certified: _____

(if applicable)

2132009



**STATE OF FLORIDA
DEPARTMENT OF BUSINESS AND PROFESSIONAL REGULATION**

**CONSTRUCTION INDUSTRY LICENSING BOARD
2601 BLAIR STONE ROAD
TALLAHASSEE FL 32399-0783**

(850) 487-1395

**BOUCHARD, DONALD JOSEPH
JASPER CONTRACTORS INC.
1690 ROBERTS BOULEVARD SUITE 112
KENNESAW GA 30144**

Congratulations! With this license you become one of the nearly one million Floridians licensed by the Department of Business and Professional Regulation. Our professionals and businesses range from architects to yacht brokers, from boxers to barbecue restaurants, and they keep Florida's economy strong.

Every day we work to improve the way we do business in order to serve you better. For information about our services, please log onto www.myfloridalicense.com. There you can find more information about our divisions and the regulations that impact you, subscribe to department newsletters and learn more about the Department's initiatives.

Our mission at the Department is: License Efficiently, Regulate Fairly. We constantly strive to serve you better so that you can serve your customers. Thank you for doing business in Florida, and congratulations on your new license!



DETACH HERE

RICK SCOTT, GOVERNOR

MATILDE MILLER, INTERIM SECRETARY

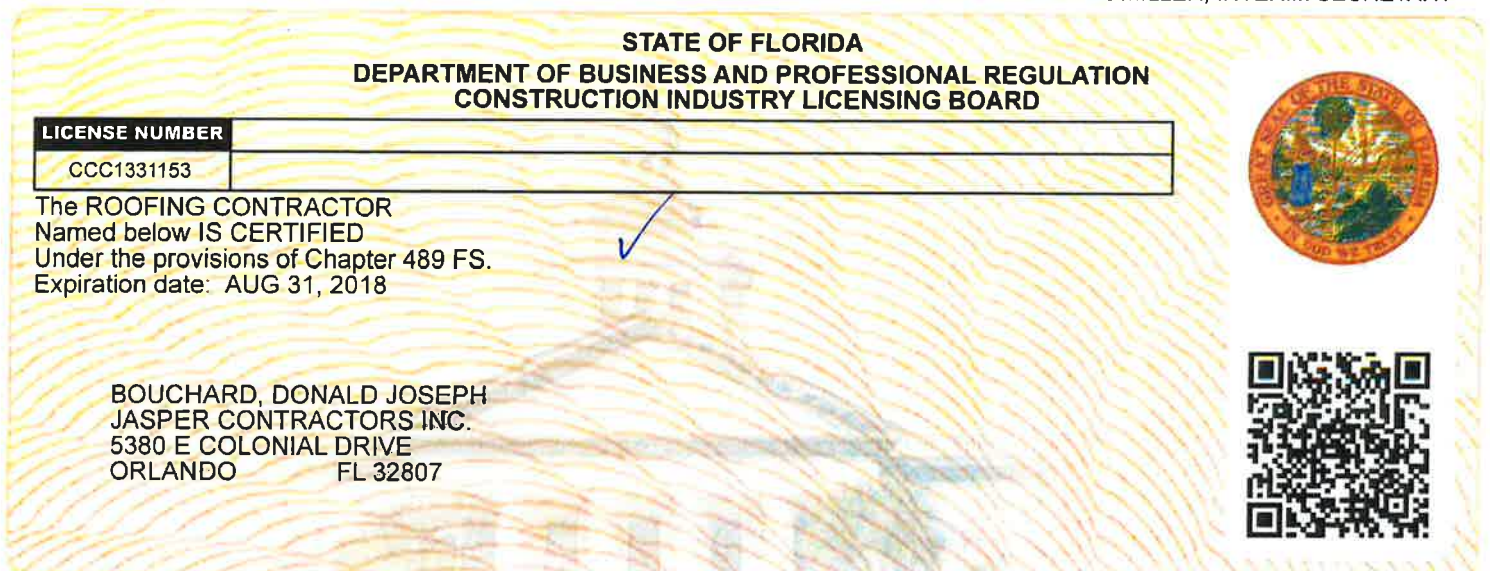

ISSUED: 03/14/2017

DISPLAY AS REQUIRED BY LAW

SEQ # L1703140000799



**STATE OF FLORIDA
DEPARTMENT OF BUSINESS AND PROFESSIONAL REGULATION**

**CONSTRUCTION INDUSTRY LICENSING BOARD
2601 BLAIR STONE ROAD
TALLAHASSEE FL 32399-0783**

(850) 487-1395

**STEPHEN, MICHAEL H
JASPER CONTRACTORS INC
1690 ROBERTS BLVD SUITE 112
KENNESAW GA 30144**

Congratulations! With this license you become one of the nearly one million Floridians licensed by the Department of Business and Professional Regulation. Our professionals and businesses range from architects to yacht brokers, from boxers to barbeque restaurants, and they keep Florida's economy strong.

Every day we work to improve the way we do business in order to serve you better. For information about our services, please log onto www.myfloridalicense.com. There you can find more information about our divisions and the regulations that impact you, subscribe to department newsletters and learn more about the Department's initiatives.

Our mission at the Department is: License Efficiently, Regulate Fairly. We constantly strive to serve you better so that you can serve your customers. Thank you for doing business in Florida, and congratulations on your new license!



DETACH HERE

RICK SCOTT, GOVERNOR

KEN LAWSON, SECRETARY

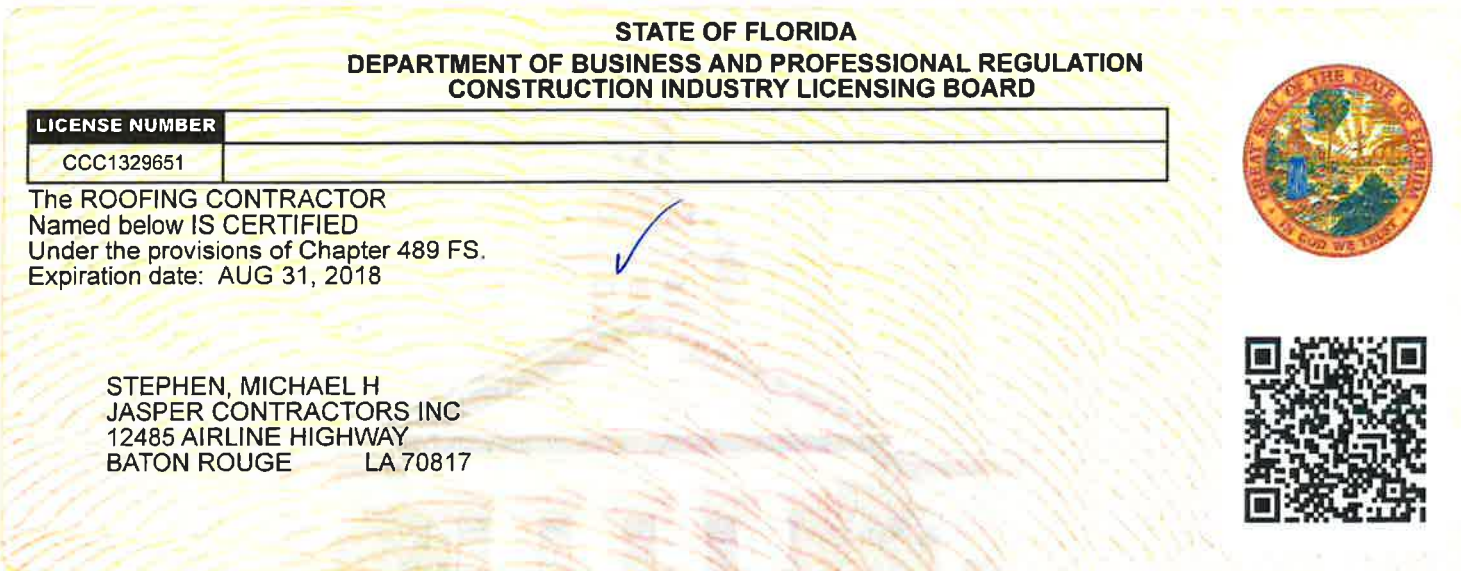

**STATE OF FLORIDA
DEPARTMENT OF BUSINESS AND PROFESSIONAL REGULATION
CONSTRUCTION INDUSTRY LICENSING BOARD**

LICENSE NUMBER	
CCC1329651	

The ROOFING CONTRACTOR
Named below IS CERTIFIED
Under the provisions of Chapter 489 FS.
Expiration date: AUG 31, 2018

**STEPHEN, MICHAEL H
JASPER CONTRACTORS INC
12485 AIRLINE HIGHWAY
BATON ROUGE LA 70817**



ISSUED: 08/17/2016

DISPLAY AS REQUIRED BY LAW

SEQ # L1608170000585



CERTIFICATE OF LIABILITY INSURANCE

DATE (MM/DD/YYYY)

2/12/2018

THIS CERTIFICATE IS ISSUED AS A MATTER OF INFORMATION ONLY AND CONFERS NO RIGHTS UPON THE CERTIFICATE HOLDER. THIS CERTIFICATE DOES NOT AFFIRMATIVELY OR NEGATIVELY AMEND, EXTEND OR ALTER THE COVERAGE AFFORDED BY THE POLICIES BELOW. THIS CERTIFICATE OF INSURANCE DOES NOT CONSTITUTE A CONTRACT BETWEEN THE ISSUING INSURER(S), AUTHORIZED REPRESENTATIVE OR PRODUCER, AND THE CERTIFICATE HOLDER.

IMPORTANT: If the certificate holder is an ADDITIONAL INSURED, the policy(ies) must be endorsed. If SUBROGATION IS WAIVED, subject to the terms and conditions of the policy, certain policies may require an endorsement. A statement on this certificate does not confer rights to the certificate holder in lieu of such endorsement(s).

PRODUCER Pritchard & Jerden, Inc. 950 East Paces Ferry Road, NE Suite 2000 Atlanta GA 30326	CONTACT NAME: Cariell McLeish	
	PHONE (A/C, No, Ext): 404-238-1084	FAX (A/C, No): 404-261-5440
E-MAIL ADDRESS: cmcleish@pjins.com		
INSURER(S) AFFORDING COVERAGE		NAIC #
INSURER A : UNITED SPECIALTY INS CO		12537
INSURER B : AMERICAN INTERSTATE INS CO		31895
INSURER C :		
INSURER D :		
INSURER E :		
INSURER F :		

COVERAGES **CERTIFICATE NUMBER:** 934740570 **REVISION NUMBER:**

THIS IS TO CERTIFY THAT THE POLICIES OF INSURANCE LISTED BELOW HAVE BEEN ISSUED TO THE INSURED NAMED ABOVE FOR THE POLICY PERIOD INDICATED. NOTWITHSTANDING ANY REQUIREMENT, TERM OR CONDITION OF ANY CONTRACT OR OTHER DOCUMENT WITH RESPECT TO WHICH THIS CERTIFICATE MAY BE ISSUED OR MAY PERTAIN, THE INSURANCE AFFORDED BY THE POLICIES DESCRIBED HEREIN IS SUBJECT TO ALL THE TERMS, EXCLUSIONS AND CONDITIONS OF SUCH POLICIES. LIMITS SHOWN MAY HAVE BEEN REDUCED BY PAID CLAIMS.

INSR LTR	TYPE OF INSURANCE	ADDL INSR	SUBR WVD	POLICY NUMBER	POLICY EFF (MM/DD/YYYY)	POLICY EXP (MM/DD/YYYY)	LIMITS
A	GENERAL LIABILITY <input checked="" type="checkbox"/> COMMERCIAL GENERAL LIABILITY <input type="checkbox"/> CLAIMS-MADE <input type="checkbox"/> OCCUR GEN'L AGGREGATE LIMIT APPLIES PER: <input type="checkbox"/> POLICY <input checked="" type="checkbox"/> PRO-JECT <input type="checkbox"/> LOC			ATN-ATL1720054	1/1/2018	1/1/2019	EACH OCCURRENCE \$ 1,000,000 DAMAGE TO RENTED PREMISES (Ea occurrence) \$ 50,000 MED EXP (Any one person) \$ 0 PERSONAL & ADV INJURY \$ 1,000,000 GENERAL AGGREGATE \$ 2,000,000 PRODUCTS - COMP/OP AGG \$ 2,000,000 Employee Benefits \$ 1,000,000
	AUTOMOBILE LIABILITY <input type="checkbox"/> ANY AUTO <input type="checkbox"/> ALL OWNED AUTOS <input type="checkbox"/> HIRED AUTOS <input type="checkbox"/> SCHEDULED AUTOS <input type="checkbox"/> NON-OWNED AUTOS						COMBINED SINGLE LIMIT (Ea accident) \$ BODILY INJURY (Per person) \$ BODILY INJURY (Per accident) \$ PROPERTY DAMAGE (Per accident) \$ \$
	UMBRELLA LIAB <input type="checkbox"/> OCCUR EXCESS LIAB <input type="checkbox"/> CLAIMS-MADE DED RETENTION \$						EACH OCCURRENCE \$ AGGREGATE \$ \$
B	WORKERS COMPENSATION AND EMPLOYERS' LIABILITY ANY PROPRIETOR/PARTNER/EXECUTIVE OFFICER/MEMBER EXCLUDED? (Mandatory in NH) If yes, describe under DESCRIPTION OF OPERATIONS below	Y/N	N/A	AVWCFL2574242017	2/12/2018	2/12/2019	<input checked="" type="checkbox"/> WC STATUTORY LIMITS <input type="checkbox"/> OTHER E.L. EACH ACCIDENT \$ 500,000 E.L. DISEASE - EA EMPLOYEE \$ 500,000 E.L. DISEASE - POLICY LIMIT \$ 500,000

DESCRIPTION OF OPERATIONS / LOCATIONS / VEHICLES (Attach ACORD 101, Additional Remarks Schedule, if more space is required)

CERTIFICATE HOLDER **CANCELLATION**

City of Belle Isle 1600 Nela Avenue Belle Isle FL 32809	SHOULD ANY OF THE ABOVE DESCRIBED POLICIES BE CANCELLED BEFORE THE EXPIRATION DATE THEREOF, NOTICE WILL BE DELIVERED IN ACCORDANCE WITH THE POLICY PROVISIONS. AUTHORIZED REPRESENTATIVE <i>Michael Mellars</i>
---	---

Scott Randolph, Tax Collector Local Business Tax Receipt Orange County, Florida

This local business tax receipt is in addition to and not in lieu of any other tax required by law or municipal ordinance. Businesses are subject to regulation of zoning, health and other lawful authorities. This receipt is valid from October 1 through September 30 of receipt year. **Delinquent penalty is added October 1.**

2017 **EXPIRES 9/30/2018** 1806-1147430
1806 ROOFING CONTRACTOR \$30.00 1 EMPLOYEE 5000 BUSINESS OFFICE \$50.00 55 EMPLOYEE

TOTAL TAX \$80.00
PREVIOUSLY PAID \$80.00
TOTAL DUE \$0.00

WEDDING BRIAN
STEPHEN MICHAEL H (QUALIFIER)

JASPER CONTRACTORS INC
1690 ROBERTS BLVD NW STE 112
KENNESAW GA 30144-7830

5380 E COLONIAL DR
U - ORLANDO, 32807

PAID: \$80.00 0098-00782908 7/18/2017

Scott Randolph, Tax Collector Local Business Tax Receipt Orange County, Florida

This local business tax receipt is in addition to and not in lieu of any other tax required by law or municipal ordinance. Businesses are subject to regulation of zoning, health and other lawful authorities. This receipt is valid from October 1 through September 30 of receipt year. **Delinquent penalty is added October 1.**

2017 **EXPIRES 9/30/2018** 1806-1147430
1806 ROOFING CONTRACTOR \$30.00 1 EMPLOYEE 5000 BUSINESS OFFICE \$50.00 55 EMPLOYEE

TOTAL TAX \$80.00
PREVIOUSLY PAID \$80.00
TOTAL DUE \$0.00



• WEDDING BRIAN
STEPHEN MICHAEL H (QUALIFIER)
JASPER CONTRACTORS INC
1690 ROBERTS BLVD NW STE 112
KENNESAW GA 30144-7830

5380 E COLONIAL DR
U - ORLANDO, 32807

PAID: \$80.00 0098-00782908 7/18/2017

This receipt is official when validated by the Tax Collector.

Scott Randolph, Tax Collector

Local Business Tax Receipt

Orange County, Florida

This local business tax receipt is in addition to and not in lieu of any other tax required by law or municipal ordinance. Businesses are subject to regulation of zoning, health and other lawful authorities. This receipt is valid from October 1 through September 30 of receipt year. Delinquent penalty is added October 1.

2017 **EXPIRES 9/30/2018** 5000-1183041
5000 BUSINESS OFFICE \$40.00 12 EMPLOYEE 1806 CERT ROOFING CONTR \$30.00 1 EMPLOYEE

TOTAL TAX \$70.00
PREVIOUSLY PAID \$70.00
TOTAL DUE \$0.00

WEDDING BRIAN
BOUCHARD DONALD JOSEPH-QUALIFIER

JASPER CONTRACTORS INC
WEDDING BRIAN
1690 ROBERTS BLVD #112
KENNESAW GA 30144

3203 S CONWAY RD #201
U - ORLANDO, 32812

PAID: \$70.00 0098-00782906 7/18/2017

Scott Randolph, Tax Collector Local Business Tax Receipt Orange County, Florida

This local business tax receipt is in addition to and not in lieu of any other tax required by law or municipal ordinance. Businesses are subject to regulation of zoning, health and other lawful authorities. This receipt is valid from October 1 through September 30 of receipt year. Delinquent penalty is added October 1.

2017 **EXPIRES 9/30/2018** 5000-1183041
5000 BUSINESS OFFICE \$40.00 12 EMPLOYEE 1806 CERT ROOFING CONTR \$30.00 1 EMPLOYEE

TOTAL TAX \$70.00
PREVIOUSLY PAID \$70.00
TOTAL DUE \$0.00



• WEDDING BRIAN
BOUCHARD DONALD JOSEPH-QUALIFIER
JASPER CONTRACTORS INC
WEDDING BRIAN
1690 ROBERTS BLVD #112
KENNESAW GA 30144

3203 S CONWAY RD #201
U - ORLANDO, 32812

PAID: \$70.00 0098-00782906 7/18/2017

This receipt is official when validated by the Tax Collector.