



# City of Belle Isle

Universal Engineering Sciences 3532 Maggie Blvd., Orlando, FL 32811  
Tel 407-581-8161 \* Fax 407-581-0313 \* [www.universallenginering.com](http://www.universallenginering.com)

## PERMIT CARD - PLEASE POST AT JOB SITE

THIS DOCUMENT BECOMES YOUR PERMIT WHEN PROPERLY VALIDATED

Per FBC 105.3.3: An enforcing authority may not issue a building permit for any building construction, erection, alteration, modification, repair or addition unless the permit either includes on its face or there is attached to the permit the following statement: "NOTICE: In addition to the requirements of this permit, there may be additional restrictions applicable to this property that may be found in the public records of this county, and there may be additional permits required from other governmental entities such as water management districts, state agencies, or federal agencies." The issuance of this permit does not grant permission to violate any applicable City, Orange County, State of Florida and/or Federal codes and/or ordinances. Separate permits are required for Signs, Roofing, Electrical, Gas, Plumbing and Mechanical services. This permit becomes VOID if the work authorized is not commenced within 6 months, or is suspended or abandoned for a period of 6 months after commencement. WORK SHALL BE CONSIDERED SUSPENDED IF AN APPROVED INSPECTION HAS NOT BEEN MADE WITHIN A 6-MONTH PERIOD. PERMISSION IS GRANTED TO DO THE FOLLOWING WORK ACCORDING TO THE CONDITIONS HEREON AND THE APPROVED PLANS AND SPECIFICATIONS, SUBJECT TO COMPLIANCE WITH THE ORDINANCES OF THE CITY OF BELLE ISLE, FLORIDA.

Scope of Work: REROOF: 37sq, asphalt shingles

Comments: None

### Project Information

Address: 4333 Kandra Court, Belle Isle, FL 32812

Parcel ID: 20-23-30-1646-00-410

Property Owner: Soth, Harris

Phone Number: 407-255-6572

\*\*\*\*\* BY OWNER \*\*\*\*\*

Company Name: BY OWNER

Contractor Name:

License Number:

Address:

Phone Number:

Permit Number: 2015-10-002

Date of Application: 10/15/2014

Date Permit Issued: 10/15/2014

**WARNING TO OWNER:** "YOUR FAILURE TO RECORD A NOTICE OF COMMENCEMENT MAY RESULT IN YOU PAYING TWICE FOR IMPROVEMENTS TO YOUR PROPERTY. IF YOU INTEND TO OBTAIN FINANCING, CONSULT WITH YOUR LENDER OR AN ATTORNEY BEFORE RECORDING YOUR NOTICE OF COMMENCEMENT." ON THE JOB INSPECTION(S) MUST BE MADE BEFORE PROCEEDING WITH SUBSEQUENT WORK. THIS CARD MUST BE DISPLAYED OUTSIDE AND BE PROTECTED FROM THE WEATHER WHILE BEING VISIBLE FROM THE STREET UNTIL THE FINAL INSPECTIONS HAVE BEEN APPROVED.

### BUILDING FEATURES

#### IMPACT FEES

School \$  
Traffic \$

#### ZONING FEES

Zoning Fee \$30.00

#### UNIVERSAL ENG - BUILDING FEES

Boat Dock \$  
Boat House \$  
Building \$  
Demo \$  
Door(s) \$  
Driveway \$  
Electrical \$  
Fence \$  
Gas \$  
Irrigation \$  
Low Voltage \$  
Mechanical \$  
Plumbing \$  
Pool \$  
Roofing \$80.00  
Screen Encl \$  
Shed \$  
Temp Pole \$  
Window(s) \$

#### SURCHARGE FEES

Surcharge Fee \$2.00  
Surcharge Fee \$2.00

**TOTAL FEES \$114.00**

Date Paid 10-17-14

CC or Check # 114066993

Amount Paid 114.00

The person accepting this permit shall conform to the terms of the application on file and construction shall conform to the requirements of the Florida Building Code (FS 553).

#### BUILDING INSPECTOR USE ONLY

IF APPLICABLE:

Have Zoning Approval Conditions Been Met? YES NO Have Stormwater Approval Conditions

Been Met? YES NO Silt fencing in place? YES NO Turbidity Barrier in place? YES NO

€ BUILDING

1<sup>st</sup> \_\_\_\_\_ (Footing/Foundation)

2<sup>nd</sup> \_\_\_\_\_ (Slab)

Survey specific foundation plan must be onsite before slab pour. Approved Plan on Site? \_\_\_\_\_

3<sup>rd</sup> \_\_\_\_\_ (Lintel) (Wall Reinforcing on Masonry Building)

4<sup>th</sup> \_\_\_\_\_ (Exterior Framing) (Roof/Wall Sheathing)

5<sup>th</sup> \_\_\_\_\_ (Framing) (To be made after Plumbing/ Mechanical/ Electrical Rough-Ins & Windows/Doors Installed)

6<sup>th</sup> \_\_\_\_\_ (Insulation to be Made After Roof Installed)

7<sup>th</sup> \_\_\_\_\_ (Drywall)

8<sup>th</sup> \_\_\_\_\_ (Sidewalk/Driveway)

9<sup>th</sup> \_\_\_\_\_ (Other)

10<sup>th</sup> \_\_\_\_\_ (Final - After MEP and Other Applicable Finals)

€ ROOFING OSHA APPROVED ACCESS MUST BE MADE AVAILABLE TO INSPECTOR

1<sup>ST</sup> ROOFING Deck Nailing/Dry-in/Flashing \_\_\_\_\_

2<sup>nd</sup> ROOFING Covering In-Progress \_\_\_\_\_

3<sup>rd</sup> ROOFING Covering Final \_\_\_\_\_

€ PLUMBING (Pool-Piping, Solar, Irrigation, Water Treatment Equip, Etc...)

€ 1<sup>ST</sup> \_\_\_\_\_ (Underground) 2<sup>nd</sup> \_\_\_\_\_ (Sewer)

3<sup>rd</sup> \_\_\_\_\_ (Rough-In/Tub Set) 4<sup>th</sup> \_\_\_\_\_ (Final)

CHECK APPROPRIATE BOX

€ GAS \_\_\_ Natural \_\_\_ LP € MECHANICAL € ELECTRICAL € LOW VOLTAGE

1<sup>st</sup> \_\_\_\_\_ (Rough-In) 2<sup>nd</sup> \_\_\_\_\_ (Final)

Inspection requests are to be emailed to [BidScheduling@UniversalEngineering.com](mailto:BidScheduling@UniversalEngineering.com); a confirmation email will be sent back to you upon scheduling. Next-Day Inspection requests must be made by 1pm. Please include the following in your request: Permit #, project address, type of inspection, date of the requested inspection, a contact name & a contact phone number. AM or PM may be requested but cannot be guaranteed.

For a copy of your permit, or to check inspection results, please visit <https://universallenginering.sharefile.com>

login ID = [cobi@universallenginering.com](mailto:cobi@universallenginering.com)

password = universal13



**City of Belle Isle**  
 Universal Engineering Sciences 3532 Maggie Blvd., Orlando, FL 32811  
 Tel 407-581-8161 \* Fax 407-581-0313 \* [www.universaleengineering.com](http://www.universaleengineering.com)

**Received**  
 10-15-14

**APPLICATION FOR ROOFING PERMIT**

**WARNING TO OWNER:** YOUR FAILURE TO RECORD A NOTICE OF COMMENCEMENT MAY RESULT IN YOUR PAYING TWICE FOR IMPROVEMENTS TO YOUR PROPERTY. A NOTICE OF COMMENCEMENT MUST BE RECORDED AND POSTED ON THE JOB SITE BEFORE THE FIRST INSPECTION. IF YOU INTEND TO OBTAIN FINANCING, CONSULT WITH YOUR LENDER OR AN ATTORNEY BEFORE RECORDING YOUR NOTICE OF COMMENCEMENT.

**DATE OF APPLICATION:** 10/15/2014      **ROOF PERMIT NUMBER:** 2015-10-002  
 PLEASE PRINT. The undersigned hereby applies for a permit to make installations as indicated below:  
 Project Address 4333 KANDRA COURT      Belle Isle, FL  32809  32812  
 Property Owner HARRIS SOTH      Phone 407-255-6572  
 Property Owner's Mailing Address 4333 KANDRA COURT      City BELLE ISLE  
 State FL      Zip Code 32812      Parcel Id Number 20-23-30-1646-00-410

REQUIRED! To obtain this information, please visit <http://www.ocpafi.org/Searches/ParcelSearch.aspx>

**Class of Building:** Old  New       **Type of Building:** Residential  Commercial  Other   
**Type of Work:** New Roof  ReRoof  REPAIR.

- **REQUIRED!** Florida Product Approval Screen Printout from [www.floridabuilding.org](http://www.floridabuilding.org) showing the Code Version
- **REQUIRED!** Florida Product Approval Installation Instructions from [www.floridabuilding.org](http://www.floridabuilding.org) (not the manufacturer instructions)
- **REQUIRED!** Copies of your General Liability & Worker's Comp Insurance Certificate & State and Local Licenses

Please indicate the nature of work by completing the information below:

**Roof Square Footage:** 3700      **Number of Stories:** 1      **Job Valuation:** \$ 2000  
37sq x 300' = 11,100'

**Type:** Asphalt Shingles  Metal  Modified Bitumen  Other: \_\_\_\_\_

I hereby certify that the above is true and correct to the best of my knowledge and make Application for Permit as outlined above, and if same is granted I agree to conform to all Florida Building Code Regulations and City Ordinances regulating same and in accordance with plans submitted. The issuance of this permit does not grant permission to violate any applicable Town and/or State of Florida codes and/or ordinances. By signing below, I recognize Republic Services is by legal contract the sole authorized provider of garbage, recycling, yard waste, and commercial garbage and construction debris collection and disposal services with the city limits of the City. Contractors, homeowners and commercial businesses may contact Republic Services at 407-293-8000 to setup accounts for Commercial, Construction Roll Off, or other services needed. Rates are fixed by contract and are available at City Hall or from Republic Services. The City enforces the contract through its code enforcement office. Failure to comply will result in a stop work order.

**LICENSE HOLDER SIGNATURE:** Harris Soth      **LICENSE #:** BY OWNER HARRIS SO  
**LICENSE HOLDER NAME:** BY OWNER HARRIS SOTH      **COMPANY NAME:** BY OWNER

**Street Address:** 4333 KANDRA COURT      **State:** FL      **Zip Code:** 32812      **Phone Number:** 407 255 6572  
**City:** BELLE ISLE  
**Email Address:** Hsoth01@yahoo.com

**Building Official:** seq      **Date:** 10-15-14  
**Verified Contractor's Licenses & Insurance are on file:** na      **Date:** \_\_\_\_\_

**Zoning Fee:** \$ 30<sup>00</sup>  
**Permit Fee:** \$ 80<sup>00</sup>  
**Review Fee:** \$ na  
**3% Florida Surcharge:** \$ 4<sup>00</sup>  
**Total Permit Fee:** \$ 114<sup>00</sup>

**NOTE:** The Building Permit Number is required if the Roof Installation is associated with any construction or alteration where a Building Permit has been issued.

1000<sup>00</sup> - 25<sup>00</sup>  
10,100<sup>00</sup> - 55<sup>00</sup>  
80<sup>00</sup>



## City of Belle Isle

Universal Engineering Sciences 3532 Maggie Blvd., Orlando, FL 32811  
Tel 407-581-8161 \* Fax 407-581-0313 \* [www.universalsengineering.com](http://www.universalsengineering.com)

### **OWNER BUILDER DISCLOSURE STATEMENT**

Per Florida Statue 455.228:

Homeowners hiring unlicensed Contractors may be subject a fine of up to \$5,000.00!

Before me this day personally appeared Harri S. SotH, who being duly sworn, deposes, and says as follows. "I hereby acknowledge that I have read and fully understand the individual provisions of this instrument."

1. I understand that state law requires construction to be done by a licensed contractor and have applied for an owner-builder permit under an exemption from the law. The exemption specifies that I, as the owner of the property listed, may act as my own contractor with certain restrictions even though I do not have a license  
HS Initial
2. I understand that building permits are not required to be signed by a property owner unless he or she is responsible for the construction and is not hiring a licensed contractor to assume responsibility. \_\_\_\_\_ Initial
3. I understand that, as an owner-builder, I am the responsible party of record on a permit. I understand that I may protect myself from potential financial risk by hiring a licensed contractor and having the permit filed in his or her name instead of my own name. I also understand that a contractor is required by law to be licensed in Florida and to list his or her license numbers on permits and contracts. HS Initial
4. I understand that I may build or improve a one-family or two-family residence or a farm outbuilding. I may also build or improve a commercial building if the costs do not exceed \$75,000.00. The building or residence must be for my own use or occupancy. It may not be built or substantially improved for sale or lease. If a building or residence that I have built or substantially improved myself is sold or leased within 1 year after the construction is complete, the law will presume that I built or substantially improved it for sale or lease, which violates the exemption. HS Initial
5. I understand that, as the owner-builder, I must provide direct, onsite supervision of the construction. HS Initial
6. I understand that I may not hire an unlicensed person to act as my contractor or to supervise persons working on my building or residence. It is my responsibility to ensure that the persons whom I employ have the licenses required by law and by county or municipal ordinance. HS Initial
7. I understand that it is a frequent practice of unlicensed persons to have the property owner obtain an owner-builder permit, that erroneously implies that the property owner is providing his or her own labor and materials. I, as an owner-builder, may be held liable and subjected to serious financial risk for any injuries sustained by an unlicensed person or his or her employees while working on my property. My homeowner's insurance may not provide coverage for those injuries. I am willfully acting as an owner-builder and am aware of the limits of my insurance coverage for injuries to workers on my property. HS Initial
8. I understand that I may not delegate the responsibility for supervising work to a licensed contractor who is not licensed to perform the work being done. Any person working on my building who is not licensed must work under my direct supervision and must be employed by me, which means that I must comply with laws requiring the withholding of federal income tax and social security contributions under the Federal Insurance Contributions Act (FICA) and must provide workers' compensation for the employee. I understand that my failure to follow these laws may subject me to serious financial risk. HS Initial

Owner Builder Disclosure Statement

9. I agree that, as the party legally and financially responsible for this proposed construction activity, I will abide by all applicable laws and requirements that govern owner-builders as well as employers. I also understand that the construction must comply with all applicable laws, ordinances, building codes, and zoning regulations.  
HS Initial
10. I understand that I may obtain more information regarding my obligations as an employer from the Internal Revenue Service, the United States Small Business Administration, the Florida Department of Financial Services, and the Florida Department of Revenue. I also understand that I may contact the Florida Construction Industry Licensing Board at (850)487-1395 or [www.Call.Center@cbpr.state.fl.us](http://www.Call.Center@cbpr.state.fl.us) for more information about licensed contractors. HS Initial
11. I am aware of, and consent to, an owner-builder building permit applied for in my name and understand that I am the party legally and financially responsible for the proposed construction activity at the following address:  
 Project Address: 4333 KANDRA CT BELLE ISLE FL 32812 HS Initial
12. I agree to notify the City of Belle Isle Building/Zoning Department immediately of any additions, deletions, or changes to any of the information that I have provided on this disclosure. HS Initial

Licensed contractors are regulated by laws designed to protect the public. If you contract with a person who does not have a license, the Construction Industry Licensing Board and Department of Business and Professional Regulation may be unable to assist you with financial loss that you sustain as a result of a complaint. Your only remedy against an unlicensed contractor may be in civil court. It is also important for you to understand that, if any unlicensed contractor or employee of an individual or firm is injured while working on your property, you may be held liable for damages. If you obtain an owner-builder permit and wish to hire a licensed contractor, you will be responsible for verifying whether the contractor is property licensed and the status of the contractor's workers' compensation coverage.

Before a building permit can be issued, this disclosure statement must be completed and signed by the property owner and returned to the local permitting agency responsible for issuing the permit. A copy of the property owner's driver license, the notarized signature of the property owner, or other type of verification acceptable to the local permitting agency is required when the permit is issued.

Signature: \_\_\_\_\_ (Signature of the property owner) Print: \_\_\_\_\_ (Name of the property owner)

Signature: [Signature] Print: HARRIS, SOTH  
 (Signature of the property owner) (Name of the property owner)

Owner's Address: 4333 KANDRA CT ORLANDO FL 32812

The foregoing instrument was acknowledged before me this 10 / 15 / 2015  
 by Harris S. Soth who is personally known to me / who produced the following  
FL Govt license as identification and who did not take an oath.

State of Florida / County of Orange Seal: \_\_\_\_\_

Notary Signature: [Signature]





**City of Belle Isle**  
 Universal Engineering Sciences 3532 Maggie Blvd., Orlando, FL 32811  
 Tel 407-581-8161 \* Fax 407-581-0313 \* [www.universalengineering.com](http://www.universalengineering.com)

## Product Approval Form

DATE: 10/15/2014

PERMIT # \_\_\_\_\_

PROJECT ADDRESS 4333 Kandra Ct Belle Isle

Belle Isle, FL  32809  32812

As required by Florida Statute 563.842 and Florida Administrative Code 9B-72m, please provide the information and approval numbers of the building components listed below if they will be utilized on the building or structure. FL Approved products are listed online at [www.floridabuilding.org](http://www.floridabuilding.org) or can be obtained from the local product supplier. The following information must be turned in with permit application and available onsite for inspections:

1. This Product Approval Cover Sheet
2. Internet screen from [FloridaBuilding.org](http://FloridaBuilding.org) showing PA#, approval and code edition stamped
3. Manufacturer's installation details from [FloridaBuilding.org](http://FloridaBuilding.org) and requirements for each product stamped

Product Type	Manufacturer	Model/Series	FL Product Approval #	Product Type	Manufacturer	Model/Series	FL Product Approval #
<b>EXTERIOR DOORS</b>							
Swinging				Sliding	<b>WALL PANELS</b>		
Sliding			Soffits				
Sectional/Rollup			Storefront				
Other			Glass Block				
			Other				
<b>WINDOWS</b>							
Single/Db'l Hung				Asphalt Shingles	<b>ROOFING PRODUCTS</b>		
Horizontal Slider				Non Struct Metal			
Casement				Roofing Tiles			
Fixed				Single Ply Roof			
Mullion				Other			
Skylights							
Other							
<b>STRUCTURAL COMPONENTS</b>							
Wood Connectors				<b>OTHER</b>			
Wood Anchors							
Truss Plates							
Insulation Forms							
Lintels							
Other							

It is the applicant's responsibility to verify that specific products have been installed in accordance with their limitations and with the minimum required design pressures for the structure. Specific compliance will be verified during field inspections.

Applicant Signature *Haining Lot*

Date 10/15/2014



EXTERIOR RESEARCH & DESIGN, LLC.  
*Certificate of Authorization #9503*  
353 CHRISTIAN STREET, UNIT #13  
OXFORD, CT 06478  
PHONE: (203) 262-9245  
FAX: (203) 262-9243

## EVALUATION REPORT

Owens Corning  
One Owens Corning Parkway  
Toledo, OH 43659

**Evaluation Report O37940.02.12-R4**  
**FL10674-R9**  
**Date of Issuance: 02/06/2012**  
**Revision 4: 03/04/2014**

### SCOPE:

This Evaluation Report is issued under Rule 9N-3 and the applicable rules and regulations governing the use of construction materials in the State of Florida. The documentation submitted has been reviewed by Robert Nieminen, P.E. for use of the product under the Florida Building Code and Florida Building Code, Residential Volume. The products described herein have been designed to comply with the 2010 FBC and 2010 FBC Residential Volume sections noted herein.

### DESCRIPTION: Owens Corning Asphalt Roof Shingles

**LABELING:** Each unit shall bear labeling in accordance with the requirements the Accredited Quality Assurance Agency noted herein.

**CONTINUED COMPLIANCE:** This Evaluation Report is valid until such time as the named product(s) changes, the referenced Quality Assurance documentation changes, or provisions of the Code that relate to the product change. Acceptance of this Evaluation Report by the named client constitutes agreement to notify Robert Nieminen, P.E. if the product changes or the referenced Quality Assurance documentation changes. Trinity|ERD requires a complete review of this Evaluation Report relative to updated Code requirements with each Code Cycle.

**ADVERTISEMENT:** The Evaluation Report number preceded by the words "Trinity|ERD Evaluated" may be displayed in advertising literature. If any portion of the Evaluation Report is displayed, then it shall be done in its entirety.

**INSPECTION:** Upon request, a copy of this entire Evaluation Report shall be provided to the user by the manufacturer or its distributors and shall be available for inspection at the job site at the request of the Building Official.

This Evaluation Report consists of pages 1 through 7.

### Prepared by:

**Robert J.M. Nieminen, P.E.**  
*Florida Registration No. 59166, Florida DCA AME1983*

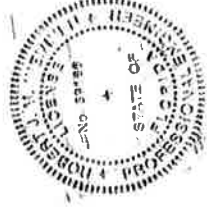

The facsimile seal appearing was authorized by Robert Nieminen, P.E. on 03/04/2014. This does not serve as an electronically signed document. Signed, sealed hardcopies have been transmitted to the Product Approval Administrator and to the named client.

### CERTIFICATION OF INDEPENDENCE:

1. Trinity|ERD does not have, nor does it intend to acquire or will it acquire, a financial interest in any company manufacturing or distributing products it evaluates.
2. Trinity|ERD is not owned, operated or controlled by any company manufacturing or distributing products it evaluates.
3. Robert Nieminen, P.E. does not have nor will acquire, a financial interest in any company manufacturing or distributing products for which the evaluation reports are being issued.
4. Robert Nieminen, P.E. does not have, nor will acquire, a financial interest in any other entity involved in the approval process of the product.

**ROOFING SYSTEMS EVALUATION:**
**1. SCOPE:**

**Product Category:** Roofing  
**Sub-Category:** Asphalt Shingles

**Compliance Statement:** Owens Corning Asphalt Roof Shingles, as produced by Owens Corning, have demonstrated compliance with the following sections of the Florida Building Code and Florida Building Code, Residential Volume through testing in accordance with the following Standards. Compliance is subject to the Installation Requirements and Limitations / Conditions of Use set forth herein.

**2. STANDARDS:**

<b>Section</b>	<b>Property</b>	<b>Standard</b>	<b>Year</b>
1507.2.5, R905.2.4	Physical Properties	ASTM D3462	2007
1507.2.7.1, R905.2.6.1	Wind Resistance	ASTM D3161, Class F	2006
1507.2.7.1, R905.2.6.1	Wind Resistance	ASTM D7158, Class H	2007

**3. REFERENCES:**

<b>Entity</b>	<b>Examination</b>	<b>Reference</b>	<b>Date</b>
UL LLC (CER9626)	Physicals & Wind Resistance	File R2453, Vol. 3	02/15/2007
UL LLC (CER9626)	Physicals & Wind Resistance	20120516-R2453	05/16/2012
UL LLC (TST9628)	Physical Properties	06CA20263	04/18/2006
UL LLC (TST9628)	Wind Resistance	11CA34308	02/18/2012
UL LLC (TST9628)	Physicals & Wind Resistance	4786093137	02/01/2014
UL LLC (TST9628)	Wind Resistance	4786126532	02/10/2014
Miami-Dade (CER1592)	Physical Properties	Classification letter	02/13/2014
UL LLC (QUA9625)	FBC HVHZ Compliance Quality Control	Various NOAs Service Confirmation R2453	Various Exp. 09/26/2014

**4. PRODUCT DESCRIPTION:**

- 4.1 Asphalt Shingles:

  - 4.1.1 Classic® and Supreme® are fiberglass reinforced, 3-tab asphalt roof shingles.
  - 4.1.2 Berkshire® are fiberglass reinforced, 4-tab asphalt roof shingles.
  - 4.1.3 Devonshire™ are fiberglass reinforced, 5-tab asphalt roof shingles.
  - 4.1.4 Duration®, TruDefinition® Duration®, Duration® Premium Cool, TruDefinition® Duration® Designer Color Collection, TruDefinition® Oakridge®, Oakridge® and WeatherGuard® HP are fiberglass reinforced, laminated asphalt roof shingles.

- 4.2 Berkshire® Hip & Ridge Shingles, High Ridge, Hip & Ridge with Sealant, WeatherGuard® HP Hip & Ridge Shingles, ProEdge Hip & Ridge Shingles and DuraRidge™ Hip & Ridge Shingles are fiberglass reinforced, hip and ridge asphalt roof shingles.
- 4.3 Starter Strip Plus and Starter Shingle Roll are starter strips for asphalt roof shingles.

**5. LIMITATIONS:**

- 5.1 This Evaluation Report is not for use in the HVHZ.
- 5.2 Fire Classification is not part of this Evaluation Report; refer to current Approved Roofing Materials Directory for fire ratings of this product.
- 5.3 Wind Classification:



- 5.3.1 All Owens Corning shingles noted herein are Classified in accordance with FBC Tables 1507.2.7.1 and R905.2.6.1 to ASTM D3161, Class F and/or ASTM D7158, Class H, indicating the shingles are acceptable for us in all wind zones up to  $V_{asd} = 150$  mph ( $V_{ult} = 194$  mph). Refer to Section 6 for installation requirements to meet this wind rating.
- 5.3.2 All Owens Corning hip & ridge shingles and Starter Strip Plus noted herein are Classified in accordance with FBC Tables 1507.2.7.1 and R905.2.6.1 to ASTM D3161, Class F, indicating the shingles are acceptable for us in all wind zones up to  $V_{asd} = 150$  mph ( $V_{ult} = 194$  mph). Refer to Section 6 for installation requirements to meet this wind rating.
- 5.3.3 Classification by ASTM D7158 applies to exposure category B or C and a building height of 60 feet or less. Calculations by a qualified design professional are required for conditions outside these limitations. Contact the shingle manufacturer for data specific to each shingle.
- 5.3.4 Refer to Owens Corning published information on wind resistance and installation limitations.
- 5.4 All products in the roof assembly shall have quality assurance audit in accordance with the Florida Building Code and F.A.C. Rule 9N-3.

## **6. INSTALLATION:**

### **6.1 Underlayment:**

- 6.1.1 Underlayment shall be acceptable to Owens Corning and shall hold current Florida Statewide Product Approval, or be Locally Approved per Rule 9N-3, per FBC Sections 1507.2.3, 1507.2.4 or R905.2.3.

### **6.2 Asphalt Shingles:**

- 6.2.1 Installation of asphalt shingles shall comply with the manufacturer's current published instructions, using minimum four (4) nails per shingle in accordance with FBC Sections 1507.2 or R905.2, with the following exceptions:
- Berkshire® shingles require minimum five (5) nails per shingle.
  - WeatherGuard® HP shingles require minimum six (6) nails per shingle.
  - Devonshire™ shingles require minimum six (6) nails per shingle.
  - Starter Strip Plus requires minimum five (5) nails per strip.
- Refer to Owens Corning published information on wind resistance and installation limitations.
- 6.2.2 Fasteners shall be in accordance with the manufacturer's published requirements, but not less than FBC 1507.2.6 or R905.2.5. Staples are not permitted.
- 6.2.4 Where the roof slope exceeds 21 units vertical in 12 units horizontal, special methods of fastening are required. Contact the shingle manufacturer for details.



6.2.5 Minimum Nailing – Classic® & Supreme:

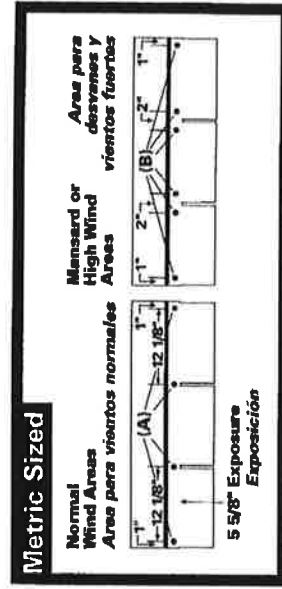
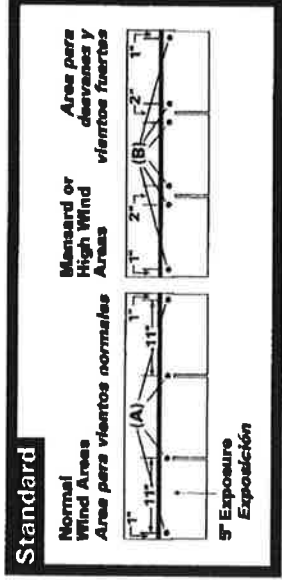

6.2.6 Minimum Nailing – Berkshire®:

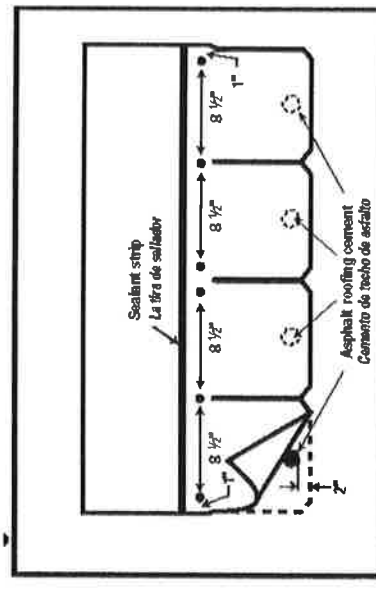
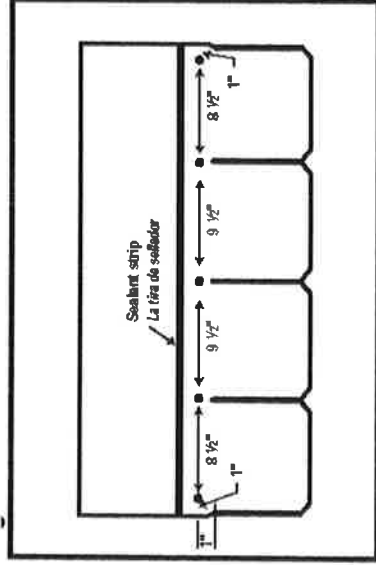

6.2.7 Minimum Nailing – Devonshire™:

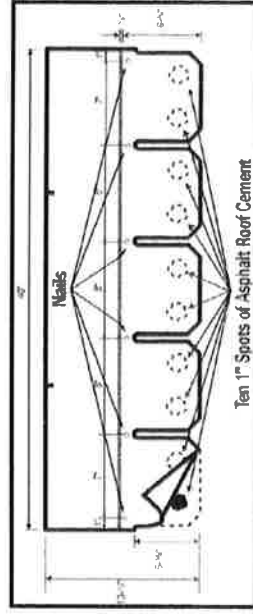
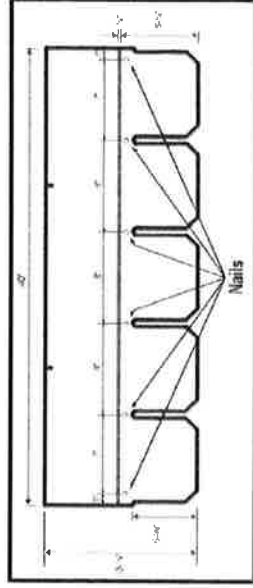

6.2.8 Minimum Nailing – Duration®, TruDefinition® Duration, Duration® Premium Cool & TruDefinition® Duration® Designer Color Collection:

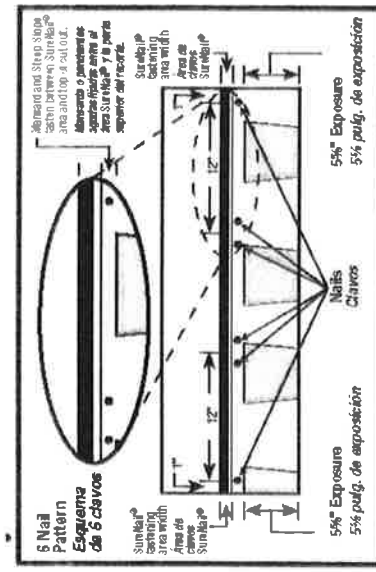
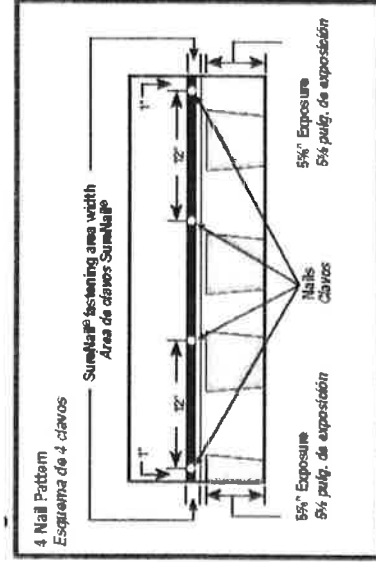

6.2.9 Minimum Nailing – TruDefinition® Oakridge®, Oakridge®:

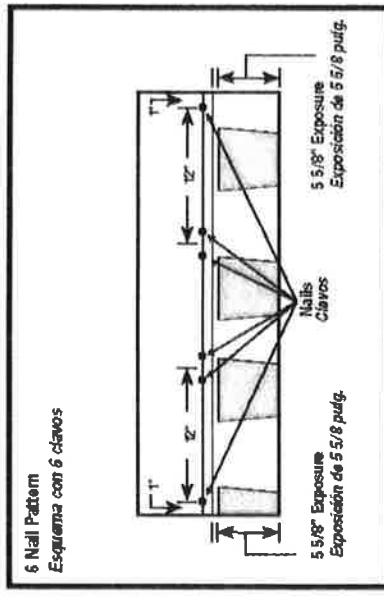
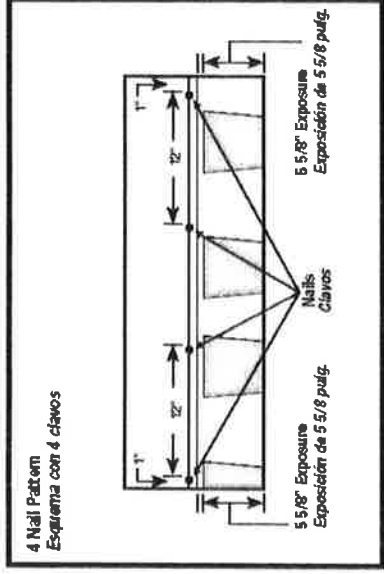

6.2.10 Minimum Nailing – WeatherGuard® HP:

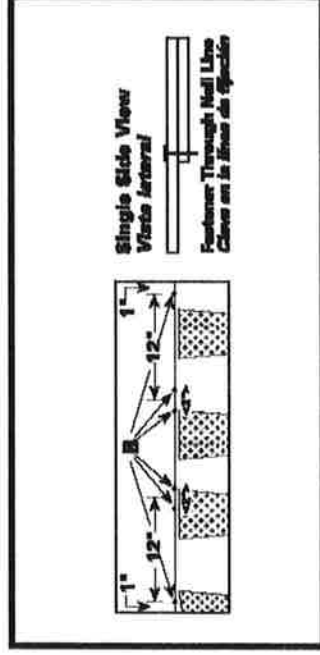

6.3 Hip & Ridge Shingles:

6.3.1

Installation of Berkshire® Hip and Ridge Shingles, High Ridge, Hip & Ridge with Sealant, WeatherGuard® HP Hip and Ridge Shingles and ProEdge Hip & Ridge Shingles shall comply with the manufacturer’s current published instructions, using four (4) nails per shingle. Installation of DuraRidge™ Hip & Ridge Shingles shall comply with the manufacturer’s current published instructions, using two (2) nails per shingle. Refer to Owens Corning published information on wind resistance and installation limitations, including the use of hand-sealing for wind warranties.

6.3.2

Fasteners shall be in accordance with the manufacturer’s published requirements, but not less than FBC 1507.2.6 or R905.2.5. Staples are not permitted.

6.3.3 Minimum Nailing – Berkshire® Hip & Ridge and High Ridge:

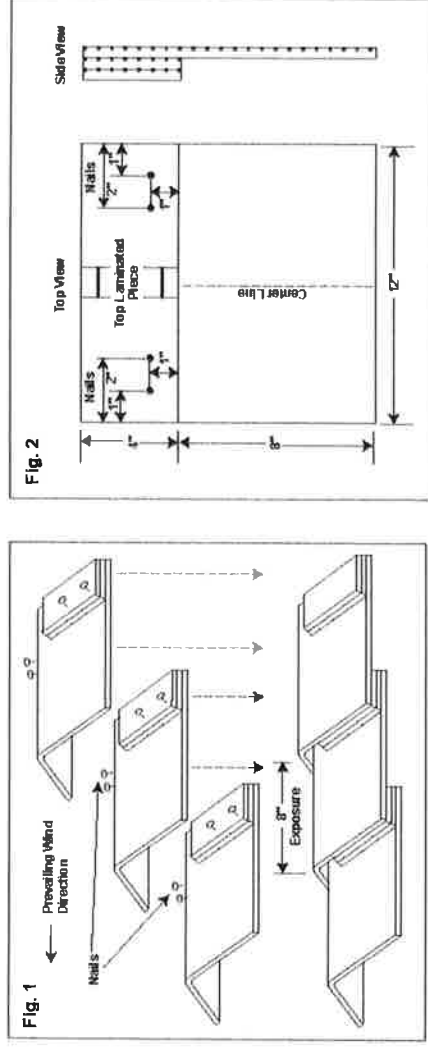

6.3.4 Minimum Nailing – Hip & Ridge with Sealant:

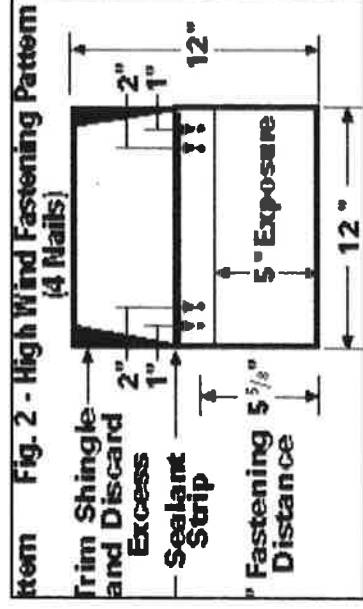

6.3.5 Minimum Nailing – WeatherGuard® HP Hip and Ridge:

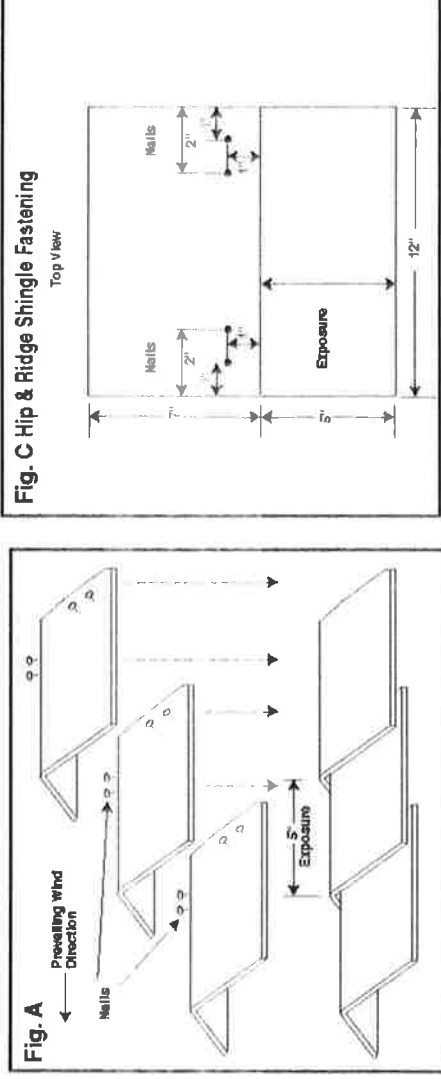

6.3.6 Minimum Nailing – ProEdge Hip & Ridge Shingles:

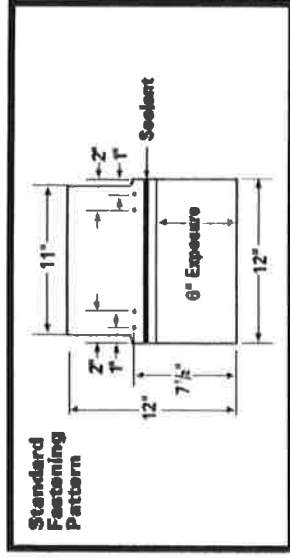
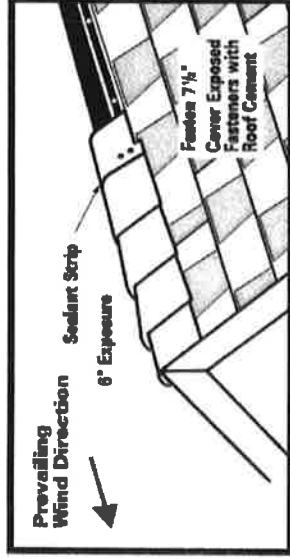

6.3.7 Minimum Nailing – DuraRidge™ Hip & Ridge Shingles:

Note: The drawings below pertain to minimum, as-tested attachment requirements. Refer to Owens Corning published installation instructions for their minimum requirements.

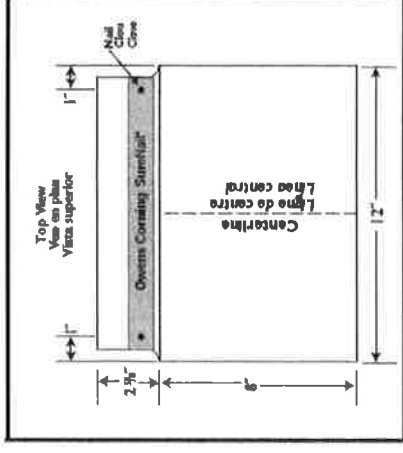
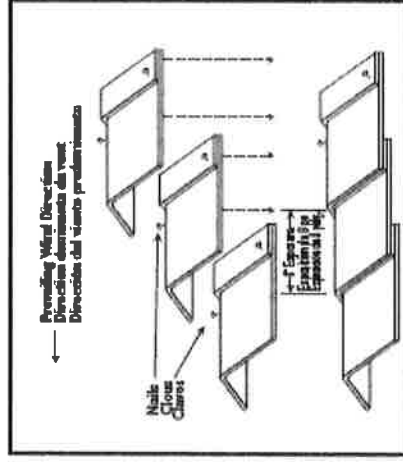

**7. LABELING:**

- 7.1 Each unit shall bear a permanent label with the manufacturer's name, logo, city, state and logo of the Accredited Quality Assurance Agency noted herein.
- 7.2 Asphalt shingle wrappers shall indicate compliance with one of the required classifications detailed in FBC Table 1507.2.7.1 / R905.2.6.1.

**8. BUILDING PERMIT REQUIREMENTS:**

As required by the Building Official or Authority Having Jurisdiction in order to properly evaluate the installation of this product.

**9. MANUFACTURING PLANTS:**

Contact the named QA entity for information on which plants produce products covered by Florida Rule 9N-3 QA requirements.

**10. QUALITY ASSURANCE ENTITY:**

UL LLC- QUA9625 ; (414) 248-6409; [karen.buchmann@ul.com](mailto:karen.buchmann@ul.com)

- END OF EVALUATION REPORT -



# Duration® Series Shingles Installation Instructions

Instrucciones Para La Instalación De Tejas Duration® Series



TruDefinition™ Duration®  
Designer Colors  
Collection Shingles

TruDefinition™ Duration®  
Shingles

Duration™ Premium  
Cool Shingles

SureNail® Fastening area  
Superficie para la colocación de clavos de SureNail®

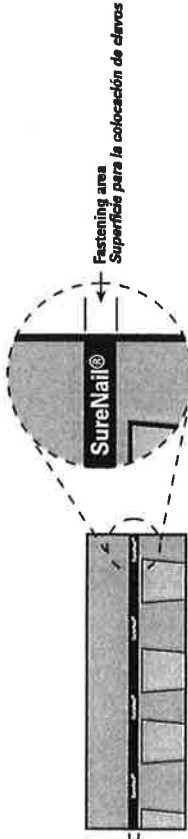

## Application Instructions

Before installing this product, check local building codes for their roofing requirements.

These shingles are designed for new or reroofing work over any properly built and supported wood roof deck having adequate nail holding capacity and a smooth surface. Check local building codes.

### Precautionary Note:

The manufacturer will not be responsible for problems resulting from any deviation from the recommended application instructions and the following precautions:

**Roof Top Loading:** Lay shingle bundles flat. Do not bend over the ridge.

**Roof Deck:** • 6" Maximum roof deck boards • Minimum 5/8" plywood  
• Minimum 7/16" OSB

Regardless of deck type used, the roofing installer must:

1. Install the deck material in strict compliance with the deck manufacturer's instructions.

2. Prevent the deck from getting wet before, during and after installation.

**Ventilation:** Must meet or exceed FHA Minimum Property Standards.

**Handling:** Use extra care in handling shingles when the temperature is below 40°F.

**Shingle Cuttings:** For best results ensure that all cutting devices are sharp and that when cutting shingles it is best to cut with a quick motion as you pull the roofing knife through the shingle.

**Storage:** Store in a covered ventilated area at a maximum temperature of 110°F. Bundles should be stacked flat. Protect shingles from weather when stored at the job site. Do not store near steam pipes, radiators, etc.

**Fastener requirements:** Use galvanized steel, stainless steel, or aluminum nails minimum 12-gauge shank with 3/8" diameter head. Owens Corning® Roofing recommends that fasteners comply with ASTM F 1667. Check local building codes.

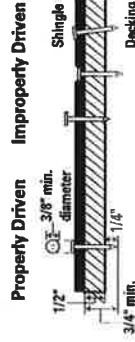

All Fasteners must penetrate at least 3/4" into the wood deck or completely through sheathing.

**Notice: Owens Corning® Roofing recommends the use of nails as the preferred method of attaching shingles to wood decking or other nailable surface.**

## Instrucciones de aplicación

Antes de colocar este producto, verifique los códigos locales de construcción para conocer los requisitos de su techo.

Estas tejas han sido diseñadas para la construcción de techos nuevos o el arreglo de techos existentes sobre plataformas de madera correctamente construidas y que poseen una capacidad de sujeción de clavos y una superficie lisa. Consulte los códigos de construcción locales.

### Aviso importante:

El fabricante no se hará responsable por los problemas que surjan como consecuencia de no seguir exactamente las instrucciones de instalación recomendadas y de los siguientes avisos importantes:

**Carga sobre los techos:** Coloque los paquetes de tejas de manera plana sobre el techo. No los doble sobre la cumbrera.

**Plataforma del techo:** • Tablas de la plataforma del techo de 6 pulg. de máximo • 5/8 pulg. como mínimo de madera triplay • 7/16 pulg. como mínimo para paneles de fibra orientada

Cualquiera que sea el tipo de superficie utilizada, el instalador del techo debe:

1. Instalar el material de la plataforma siguiendo estrictamente las instrucciones del fabricante.
2. Evitar que la plataforma se moje antes, durante y después de la instalación.

**Ventilación:** Debe cumplir o exceder las normas mínimas para propiedades, establecidas por el FHA.

**Uso:** Tenga mucho cuidado al usar y colocar las tejas cuando la temperatura sea inferior a los 40°F.

**Corte de tejas:** Para obtener mejores resultados, asegúrese de que todos los dispositivos de corte estén afilados y, cuando proceda a cortar tejas, es mejor hacer un corte con un movimiento rápido al momento en que atraviesa la teja con el cúter para techados.

**Almacenamiento:** Almacene en un área cubierta y ventilada a una temperatura que no sobrepase los 110°F/43°C. Almacene en forma plana. Proteja las tejas del clima cuando las almacene en el lugar de trabajo. No las almacene cerca de tuberías de vapor, radiadores, etc.

**Requisito de sujetador:** Use clavos de acero galvanizado, acero inoxidable o de aluminio, de calibre 12 como mínimo con un diámetro de cabeza de 3/8 pulg. Owens Corning® Roofing recomienda que los sujetadores cumplan con la norma ASTM F 1667. Consulte los códigos de construcción locales.

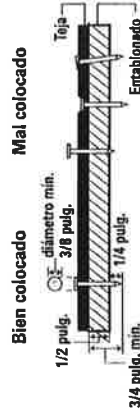

Todos los sujetadores deben penetrar al menos 3/4 pulg. en la plataforma del techo de madera o atravesar completamente los revestimientos de madera triplay.

**Aviso: Owens Corning® Roofing recomienda el uso de clavos como método preferido para fijar tejas a superficies de madera u otras superficies aptas para clavos.**

## CAUTION

**ROOF SURFACE MAY BE SLIPPERY:** Especially when wet or icy. Use a fall protection system when installing. Wear rubber soled shoes. Walk with care.

**FALLING HAZARD:** Secure area below work and materials on roof. Unsecured materials may slide on roof. Place on level plane or secure to prevent sliding. Wear a hard hat.

**WARNING:** This product contains a chemical known to the State of California to cause cancer.

## CUIDADO

**EL TECHO PUEDE ESTAR RESBALOSO:** Especialmente cuando está mojado o cubierto de hielo. Al realizar la instalación, utilice un sistema de protección contra las caídas. Utilice zapatos con suela de goma. Camine con cuidado.

**PELIGRO DE CAÍDA DE OBJETOS:** Asegure el área que se encuentra debajo de la zona de trabajo y los materiales que están sobre el techo. Los materiales que no estén sujetos pueden caerse del techo. Colóquelos en un lugar sin pendiente o sujételos para que no se caigan. Use un casco resistente.

**ADVERTENCIA:** Este producto contiene una sustancia química considerada cancerígena en el estado de California.

### Specialty Eave Flashing: Where required by code.

WeatherLock® underlayment or equivalent eave and flashing membrane applied to a point at least 24" beyond interior wall line. See manufacturer's installation instructions. See Fig. 1.

**Fig. 1** Specialty Eave Flashing  
Tapajuntas especial para aleros

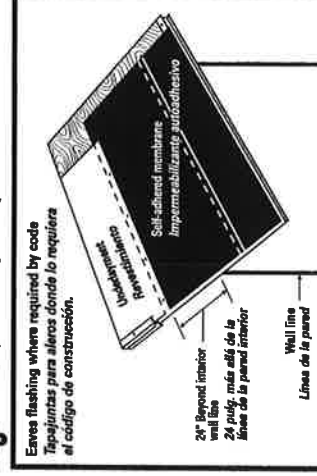

### Tapajuntas especial para aleros:

Donde lo requiera el código.

Revestimiento WeatherLock®, o impermeabilizante equivalente para aleros y tapajuntas instalada hasta un punto de al menos 24 pulg. pasando la línea de la pared interior. Consulte las instrucciones de instalación del fabricante. Ver la Fig. 1.

## 2

### Underlayment:

**Standard Slope** (4" in 12" or more)  
Application of underlayment, metal drip edges, and eaves flashing: See Fig. 2.

- (A) Apply one layer of underlayment over metal drip edge at eaves. Use only enough fasteners to hold in place.
- (B) Overlap successive courses 2". Overlap course ends 4". Side laps are to be staggered 6' apart.
- (C) Apply metal drip edge over underlayment at rake.

**Fig. 2** Underlayment Standard Slope  
Pendiente estándar del revestimiento

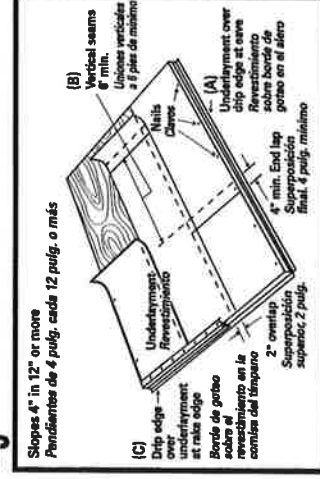

## 2

### Revestimiento:

**Pendiente estándar** (4 pulg. cada 12 pulg. o más)

Instalación del revestimiento, bordes de goteo metálicos y tapajuntas de aleros: Ver la Fig. 2.

- (A) Instale una sección del revestimiento sobre el goterón metálico del alero. Utilice la cantidad estrictamente necesaria de sujetadores para mantenerla en su lugar.
- (B) Sobreponga las hileras siguientes 2 pulg. Sobreponga los extremos de las hileras 4 pulg. Los empalmes laterales deben escalonarse a 6 pies de distancia.
- (C) Instale el borde de goteo de metal sobre el revestimiento en la cornisa.

## 3

### Underlayment:

**Low Slope** (2" in 12" to less than 4" in 12")

Application of roofing felt overlapped by 19 inches on each course. See Fig. 3.

- (A) Apply 19" starter strip of underlayment over metal drip edge at eaves. Use only enough fasteners to hold it in place.
- (B) Use 36" strip of underlayment for remaining courses, overlapping each course 19". Side laps are to be staggered 6' apart.
- (C) Apply metal drip edge over underlayment at rake.

**Fig. 3** Underlayment Low Slope  
Pendiente baja del revestimiento

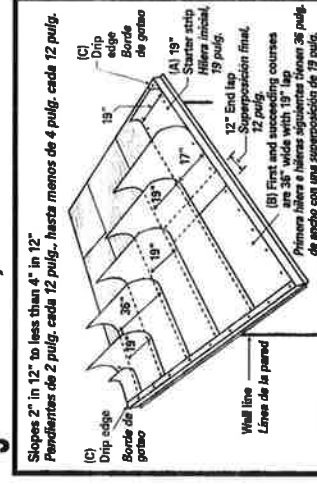

### Revestimiento:

**Pendiente baja** (2 pulg. cada 12 pulg. a menos de 4 pulg. cada 12 pulg.)

Poca pendiente (2 pulg. en 12 pulg. a menos de 4 pulg. en 12 pulg.) Aplicación de fieltro para tejado superpuesto por 19 pulg. en cada hilera. Ver la Fig. 3.

- (A) Instale una sección inicial de 19 pulg. de revestimiento sobre el goterón metálico del alero. Utilice la cantidad estrictamente necesaria de sujetadores para mantenerla en su lugar.
- (B) Use una sección de revestimiento de 36 pulg. para el resto de las hileras, sobreponiendo cada hilera 19 pulg. Los empalmes laterales deben escalonarse a 6 pies de distancia.
- (C) Instale el borde de goteo de metal sobre el revestimiento en la cornisa.

## 3

**Fig. 3A** Underlayment Low Slope  
Pendiente baja del revestimiento

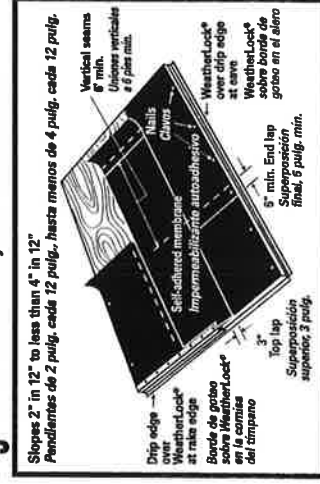

- (C) Instale el borde de goteo de metal sobre el revestimiento en la cornisa.
- O membrana autoadherente WeatherLock® o equivalente con una superposición estándar de 3 pulg. y borde de escurrimiento. Ver la Fig. 3A.

## 4

### Shingle Fastening Pattern:

Standard Fastening Pattern. Fasteners must be placed in the SureNail® fastening area. See Fig. 4.

### Six Nail Fastening Pattern.

For 6 nail fastening pattern. See Fig. 4A.

**Mansard or Steep Slope Fastening Pattern.** Place fasteners 6½" from bottom edge to secure both layers of the shingle. Fasteners need to be located 6½" above the butt edge of the shingle, regardless of whether they are in the granules or the SureNail® fastening area. See Fig. 4B.



**REQUIRED:** For slopes exceeding 60 degrees or 21" per foot, use six fasteners and four spots of asphalt cement per shingle. Apply immediately; one 1" diameter spot of asphalt cement **under** each shingle tab. Center asphalt roof cement 2" up from bottom edge of shingle tab.

**Roof Cement** where required must meet ASTM D-4586 Type I or II (Asbestos Free).

**Fig. 4** Standard Fastening Pattern  
**Esquema de instalación estándar**

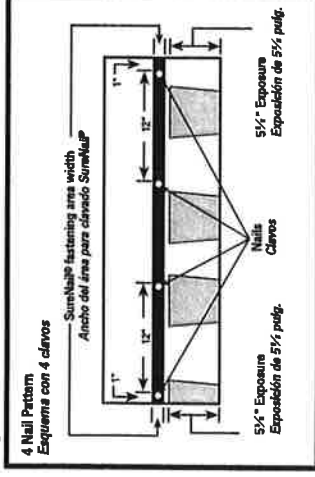

## 4

### Instalación de las tejas:

**Esquema de instalación estándar.** Los sujetadores se deben colocar en el área de instalación de clavos SureNail®. Ver la Fig. 4.

### Esquema de instalación con seis clavos.

Para un esquema de instalación con 6 clavos. Ver la Fig. 4A.

**Esquema de instalación en pendientes pronunciadas o mansardas.** Coloque los sujetadores a 6½ pulg. del borde inferior para asegurar ambas capas de tejas. Los sujetadores deben colocarse a 6½ pulg. por encima del extremo inferior de la teja, sin importar si es sobre los gránulos o el área de instalación SureNail®. Ver la Fig. 4B.



**REQUISITO:** Para pendientes de más de 60 grados o 21 pulg. por pie, utilice seis sujetadores y cuatro cantidades pequeñas de cemento asfaltado por teja. Instale inmediatamente una sección con 1 pulg. de diámetro de cemento asfaltado **debajo** de cada lengüeta de las tejas. Asegúrese de que el cemento asfaltado esté centrado 2 pulg. por encima del borde inferior de la lengüeta de la teja.

Cuando sea necesario utilizar **cemento para techos**, éste debe cumplir con la norma ASTM D-4586 Tipo I ó II (sin asbestos).

**Fig. 4A** Six Nail Fastening Pattern  
**Esquema de instalación con seis clavos**

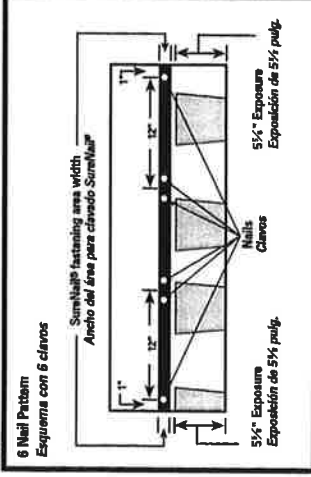

**Fig. 4B** Mansard or Steep Slope Fastening Pattern  
**Esquema de instalación en pendientes pronunciadas o mansardas**

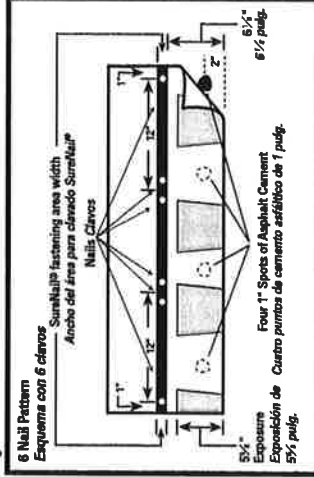

## 5

### Shingle Application:

These shingles are applied with a 6½" offset, with 5½" exposure, over prepared roof deck, starting at the bottom of the roof and working across and up. This will blend shingles from one bundle into the next and minimize any normal shade variation. Application with offsets of 4" or 5" are also acceptable.

Caution must be exercised to assure that end joints are no closer than 2" from fastener in the shingle below and that side laps are no less than 4" in succeeding courses. Refer to course application steps for specific instructions.

(continued on next page)

### 5 Instalación de las tejas:

Estas tejas se instalan con un desplazamiento de 6½ pulg. con una superficie expuesta de 5½ pulg., sobre plataformas de techos preparadas. La colocación comienza por la parte inferior del techo y se realiza en forma transversal hacia arriba. De esta manera, las tejas de un paquete se mezclan con las del siguiente y se reducen al mínimo las variaciones normales de tonalidad. También se pueden instalar tejas con un desplazamiento de 4 ó 5 pulg.

Asegúrese de que las uniones de los extremos no se encuentren a menos de 2 pulg. del sujetador de la teja que se encuentra más abajo, y que las superposiciones laterales no sean de menos de 4 pulg. en las hileras siguientes. Consulte los pasos de instalación de hileras para ver las instrucciones específicas.

(continúa en la página siguiente)



## 5

### Shingle Application (cont.):

#### Starter Course:

Use starter roll or trim  $5\frac{5}{8}$ " from the starter course shingle. Trim  $6\frac{1}{2}$ " off the rake of the starter course shingle and flush with the drip edge along the rake and eaves edge, and continue across the roof. Use 5 fasteners for each shingle, placed 2" to 3" up from eaves edge. See Fig. 5. **(If no drip edge is used, shingles must extend a minimum of  $\frac{1}{2}$ " and no more than 1" from rake and eaves edge.)**

#### First Course:

Apply first course starting with the full shingle even with the starter course. See Fig. 5A.

Fasten securely according to fastening instructions. See Fig. 4.

#### Second Course:

Remove  $6\frac{1}{2}$ " from the left end of this shingle and apply the remaining piece over and above the first course shingle and flush with edge of the first course with  $5\frac{5}{8}$ " exposure. See Fig. 5B.

Fasten securely according to fastening instructions. See Fig. 4.

#### Third Course:

Remove 13" from the left end of this shingle and apply the remaining piece over and above the second course shingle flush with edge of the second course with  $5\frac{5}{8}$ " exposure. See Fig. 5C.

Fasten securely according to fastening instructions. See Fig. 4.

(continued on next page)

**Fig. 5** Shingle Application  
*Instalación de tejas*

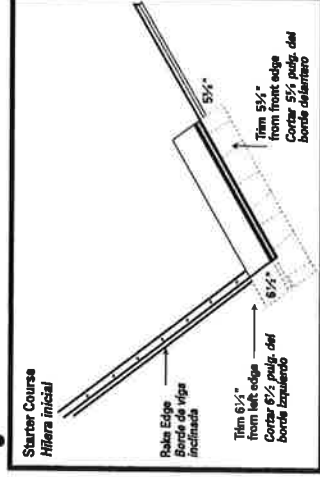

### 5 Aplicación de las tejas (cont.):

#### Hilera inicial:

Utilice un rollo de inicio o corte  $5\frac{5}{8}$  pulg. de la teja de la hilera inicial. Corte  $6\frac{1}{2}$  pulg. desde la viga inclinada en la teja de la hilera inicial y extienda más allá de la viga inclinada y el borde del alero, y continúe a lo ancho del techo. Utilice 5 sujetadores para cada teja, colocados a una distancia de entre 2 y 3 pulgadas del borde del alero. Consulte la Fig. 5. **(Si no utiliza un borde de goteo, las tejas deben extenderse un mínimo de  $\frac{1}{2}$  pulg. y un máximo de 1 pulg. de la viga inclinada y el borde del alero.)**

#### Primera hilera:

Coloque la primera hilera comenzando con la teja entera alineada con la hilera inicial. Consulte la Fig. 5A.

Sujete firmemente de acuerdo con las instrucciones de instalación. Ver la Fig. 4.

#### Segunda hilera:

Corte  $6\frac{1}{2}$  pulg. del borde izquierdo de esta teja y coloque la pieza restante sobre y hacia arriba de la teja de la primera hilera y al ras del borde de la primera hilera, con  $5\frac{5}{8}$  pulg. de exposición. Ver la Fig. 5B.

Sujete firmemente de acuerdo con las instrucciones de instalación. Ver la Fig. 4.

#### Tercera hilera:

Quite 13 pulg. del borde izquierdo de esta teja y aplique la pieza restante sobre y hacia arriba de la teja de la segunda hilera y al ras del borde de la segunda hilera, con  $5\frac{5}{8}$  pulg. de exposición. Ver la Fig. 5C.

Sujete firmemente de acuerdo con las instrucciones de instalación. Ver la Fig. 4.

(continúa en la página siguiente)

**Fig. 5A** Shingle Application  
*Instalación de tejas*

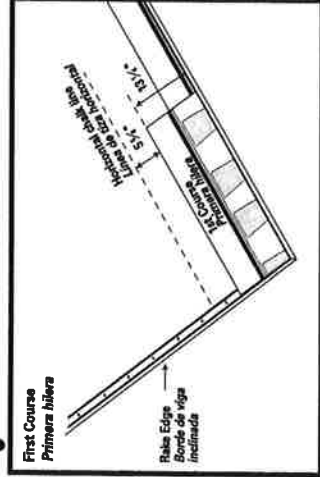

**Fig. 5B** Shingle Application  
*Instalación de tejas*

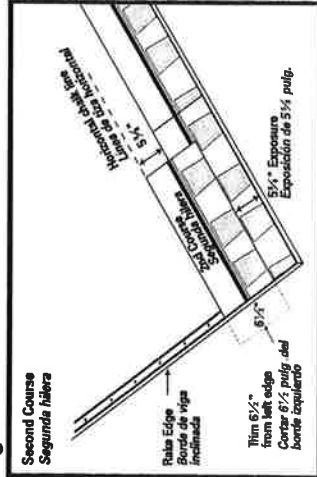

**Fig. 5C** Shingle Application  
*Instalación de tejas*

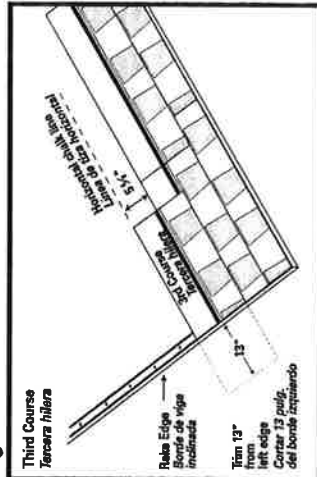

## 5 Shingle Application (cont.):

### Fourth Course:

Remove 19½" from the left end of this shingle and apply the remaining piece over and above the third course shingle and flush with edge of the third course with 5⅝" exposure. See Fig. 5D.

Fasten securely according to fastening instructions. See Fig. 4.

### Fifth Course:

Remove 26" from the left end of this shingle and apply the remaining piece over and above the fourth course shingle and flush with edge of the fourth course with 5⅝" exposure. See Fig. 5E.

Fasten securely according to fastening instructions. See Fig. 4.

### Sixth Course:

Remove 32½" from the left end of this shingle and apply the remaining piece over and above the fifth course shingle and flush with edge of the fifth course with 5⅝" exposure. See Fig. 5F.

Fasten securely according to fastening instructions. See Fig. 4.

### Succeeding Courses:

For succeeding courses, repeat first through sixth course. See Fig. 5G.

**Fig. 5D** Shingle Application  
*Instalación de tejas*

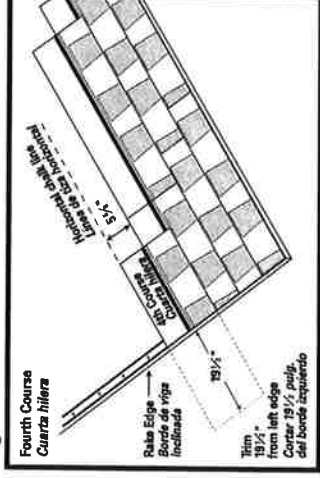

**Fig. 5E** Shingle Application  
*Instalación de tejas*

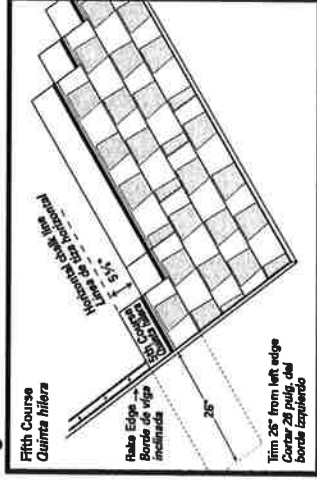

**Fig. 5F** Shingle Application  
*Instalación de tejas*

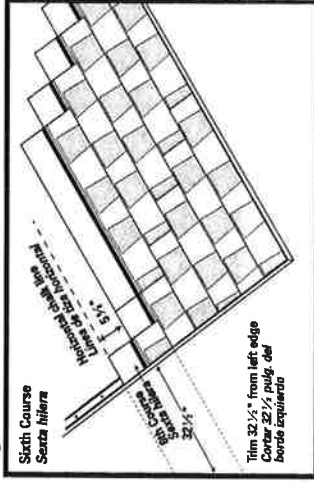

**Fig. 5G** Shingle Application  
*Instalación de tejas*

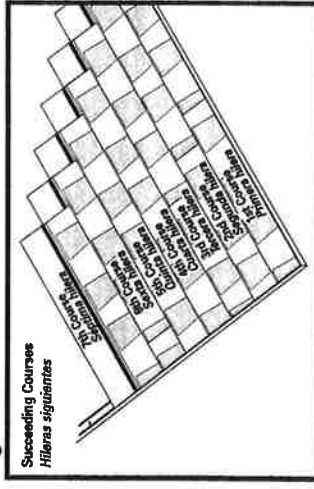

## 5 Aplicación de las tejas (cont.):

### Cuarta hilera:

Corte 19½ pulg. del borde izquierdo de esta teja y aplique la pieza restante sobre y hacia arriba de la teja de la tercera hilera y al ras del borde de la tercera hilera, con 5⅝ pulg. de exposición. Ver la Fig. 5D.

Sujete firmemente de acuerdo con las instrucciones de instalación. Ver la Fig. 4.

### Quinta hilera:

Quite 26 pulg. del borde izquierdo de esta teja y aplique la pieza restante sobre y hacia arriba de la teja de la cuarta hilera y al ras del borde de la cuarta hilera, con 5⅝ pulg. de exposición. Ver la Fig. 5E.

Sujete firmemente de acuerdo con las instrucciones de instalación. Ver la Fig. 4.

### Sexta hilera:

Corte 32½ pulg. del borde izquierdo de esta teja y coloque la pieza restante sobre y hacia arriba de la teja de la quinta hilera y al ras del borde de la quinta hilera, con 5⅝ pulg. de exposición. Ver la Fig. 5F.

Sujete firmemente de acuerdo con las instrucciones de instalación. Ver la Fig. 4.

### Hileras siguientes:

Para las hileras restantes, repita la primera a la sexta hilera. Ver la Fig. 5G.

## 6 Valley Construction:

### Closed-Cut Valley

A closed-cut valley can be used as an alternative to woven or open valley and is applied as follows:

Lay a 36" wide valley liner of self-adhered membrane underlayment or equivalent. A 36" wide minimum 50 lb. roll roofing can also be used as a valley liner.

Lay all shingles on one side of valley and across center line of valley a minimum of 12". Fasten a minimum of 6" away from center line on each side of valley.

Strike a chalk line 2" from the center line of the unshingled side. Apply shingles on the unshingled side up to the chalk line and trim, taking care not to cut the underlying shingles. Clip upper corners of these shingles, cement and fasten.

Both woven and metal valleys are acceptable alternatives.

**Fig. 6** Closed-Cut Valley Construction  
**Construcción del valle con corte cerrado**

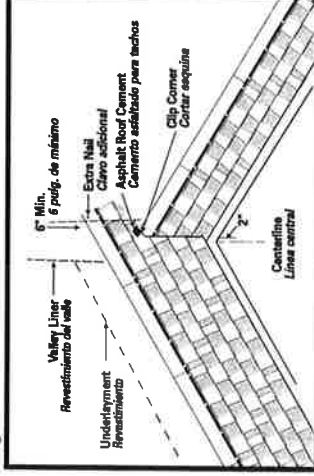

## 6 Construcción del valle:

### Valle cerrado

Un valle con corte cerrado puede ser usado como alternativa a un valle tejido o abierto y se coloca de la siguiente manera.

Coloque en el valle un impermeabilizante autoadhesivo o equivalente con 36 pulg. de ancho. Para revestir el valle, también se puede utilizar un rollo de techado de 36 pulg. de ancho y un mínimo de 50 libras.

Coloque todas las tejas sobre un lado del valle y a través de la línea central del valle al menos 12 pulg. Sujete a un mínimo de 6 pulg. de la línea central a cada lado del valle.

Marque una línea de tiza a 2 pulg. de la línea central del lado que no tiene tejas. Coloque las tejas del lado que no tiene tejas hasta la línea de tiza y recorte, con cuidado de no cortar las tejas que se encuentran debajo. Una los extremos superiores de estas tejas, coloque cemento y sujete.

Se pueden utilizar valles de tejido o metal.

## 7

### Step Flashing:

Use 10" long and 2" wider than expected exposure corrosion-resistant metal where roof planes butt against vertical sidewalls or chimneys. See Fig. 7. Check local building codes.

**Fig. 7** Step Flashing  
**Tapajuntas escalonado**

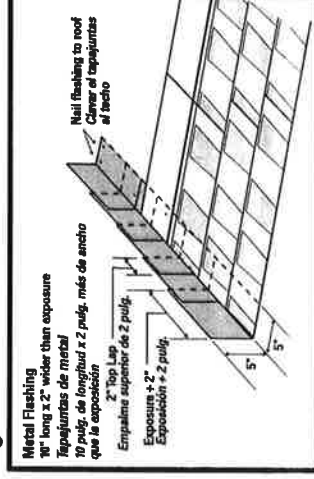

## 7 Tapajuntas escalonado:

Utilice metal resistente a la corrosión con una exposición de 10 pulg. de longitud y de 2 pulg. más de ancho que la exposición esperada en los puntos en los que los planos del techo se unan a las paredes laterales verticales o a chimeneas. Ver la Fig. 7. Consulte los códigos de construcción locales.

## 8

### Hip & Ridge Application:

Use corresponding Owens Corning™ Hip & Ridge shingles to best complement shingle color. Follow specific application instructions as printed on the Hip & Ridge shingle package. See Fig. 8.

**Fig. 8** Hip & Ridge Application  
**Instalación de caballetes y cumbreras**

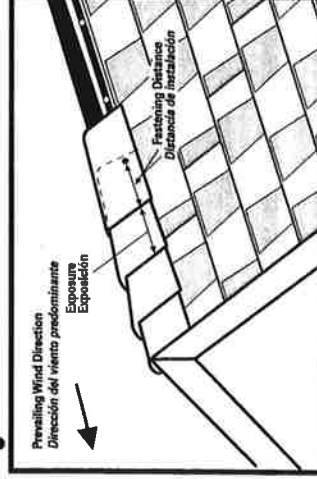

## 8 Aplicación para caballete y cumbrera:

Utilice Owens Corning™ tejas para caballetes y cumbreras. Siga las instrucciones de instalación del paquete de caballetes y cumbreras. Ver la Fig. 8.

For more information on Owens Corning™ roofing products, or any of our wide range of building products and systems, it's easy to reach us:

1-800-GET-PINK® | [www.roofing.owenscorning.com](http://www.roofing.owenscorning.com)



INNOVATION FOR LIVING®

OWENS CORNING ROOFING AND ASPHALT, LLC  
ONE OWENS CORNING PARKWAY  
TOLEDO, OHIO, USA 43859

1-800-GET-PINK®  
[www.roofing.owenscorning.com](http://www.roofing.owenscorning.com)

Pub. No. 10014283. Printed in U.S.A. - June 2011. THE PINK PANTHER™ & ©1964-2011 Metro-Goldwyn-Mayer Studios Inc. All Rights Reserved. The color PINK is a registered trademark of Owens Corning. ©2011 Owens Corning.



**Florida** *The Sunshine State*  
DRIVER LICENSE CLASS E  
**S300-337-56-202-0**  
HARRIS S  
SC TH  
4333 KANDRA CT  
ORLANDO, FL 32812-2827  
DOB: 06-02-1966 SEX: M  
ISSUED: 03-29-2014 HGT: 5-04  
EXPIRES: 06-02-2022  
REST  
ENDORSE  
*Harris S*  
SAFE DRIVER  
Operation of a motor vehicle constitutes consent to any sobriety test required by law.