



# City of Belle Isle

Universal Engineering Sciences 3532 Maggie Blvd., Orlando, FL 32811  
Tel 407-581-8161 \* Fax 407-581-0313 \* [www.universalengineering.com](http://www.universalengineering.com)

## APPLICATION FOR SIZE-FOR-SIZE WINDOW / DOOR PERMIT

WARNING TO OWNER: YOUR FAILURE TO RECORD A NOTICE OF COMMENCEMENT MAY RESULT IN YOUR PAYING TWICE FOR IMPROVEMENTS TO YOUR PROPERTY. A NOTICE OF COMMENCEMENT MUST BE RECORDED AND POSTED ON THE JOB SITE BEFORE THE FIRST INSPECTION. IF YOU INTEND TO OBTAIN FINANCING, CONSULT WITH YOUR LENDER OR AN ATTORNEY BEFORE RECORDING YOUR NOTICE OF COMMENCEMENT.

DATE OF APPLICATION: 4/9/18

PERMIT NUMBER: 208-04-030

PLEASE PRINT. The undersigned hereby applies for a permit to make installations as indicated below:

Project Address 6201 Matchett Rd., Belle Isle, FL  32809  32812  
Property Owner John Holloway Phone 407-448-0813  
Property Owner's Mailing Address 6201 Matchett Rd. City Belle Isle  
State FL Zip Code 32809 Parcel Id Number: 24-23-29-3400-00-102  
REQUIRED! To obtain this information, please visit <http://www.ocpafi.org/Searches/ParcelSearch.aspx>

Type of Building: Residential  Commercial  Other

- REQUIRED! Florida Product Approval Screen Printout from [www.floridabuilding.org](http://www.floridabuilding.org) showing the Code Version
- REQUIRED! Florida Product Approval Installation Instructions from [www.floridabuilding.org](http://www.floridabuilding.org) (not the manufacturer instructions)
- REQUIRED! Copies of your General Liability & Worker's Comp Insurance Certificate & State and Local Licenses

Please indicate the nature of work by completing the information below:

Number of Size-for-Size Windows: \_\_\_\_\_ Number of Size-for-Size Doors: 2 Job Valuation: 18,194

I hereby certify that the above is true and correct to the best of my knowledge and make Application for Permit as outlined above, and if same is granted I agree to conform to all Florida Building Code Regulations and City Ordinances regulating same and in accordance with plans submitted. The issuance of this permit does not grant permission to violate any applicable Town and/or State of Florida codes and/or ordinances. By signing below, I recognize Republic Services is by legal contract the sole authorized provider of garbage, recycling, yard waste, and commercial garbage and construction debris collection and disposal services with the city limits of the City. Contractors, homeowners and commercial businesses may contact Republic Services at 407-293-8000 to setup accounts for Commercial, Construction Roll Off, or other services needed. Rates are fixed by contract and are available at City Hall or from Republic Services. The City enforces the contract through its code enforcement office. Failure to comply will result in a stop work order.

BY SIGNING THIS APPLICATION, YOU ARE CERTIFYING THAT YOU ARE ACTING AS THE OWNER'S AGENT FOR THIS PERMIT:

LICENSE HOLDER SIGNATURE [Signature] LICENSE # CGC1518212  
LICENSE HOLDER NAME SCOTTA VARGA COMPANY NAME FASMD, LLC  
Street Address 3020 MERRY DR  
City Orlando State FL Zip Code 32808 Phone Number 407-484-8683  
Email Address jeana.mail@gmail.com

Building Official: [Signature] Date 4-11-2018  
Verified Contractor's Licenses & Insurance are on file [Signature] Date 4-11-2018

<b>PAID</b>	\$ <u>0</u>
Permit Fee	\$ <u>97.00</u>
Review Fee	\$ <u>48.50</u>
3% Florida Surcharge	\$ <u>4.18</u>
<b>Total Permit Fee</b>	\$ <u>149.68</u>

15% UC + x18 = 25  
25 + 97 = 122  
122 + 48.50 = 170.50  
170.50 = 2.00 min  
1.5% = 2.18  
170.50 + 2.18 = 172.68



**City of Belle Isle Job Site Card Window/Door PERMIT 2018- 04 - 030**

**PERMIT MUST BE POSTED ON SITE** - A permit expires in 6 months if approved inspections are not recorded /scheduled within that time frame. **You are responsible for scheduling and keeping track of all your inspections -**

Permit Number: 2018- 04-030  
Site Address: 6201 Matchett Rd. 32809  
Class:  Residential  
Description of Work: Replace (2) two doors size for size

Issue Date: 04/11/2018  
Parcel # 24-23-29-3400-00-162  
Subdivision:

Issued To: FASWD LLC  
Name: VARGA, SCOTT ALEXANDER

Business Phone: 407 489-8683  
Contractor License # CGC1518212

Payment Date & Method: 4 / 11 / 2018

Visa  Master Card  Amex  Discover  Check / Money Order # 5296

Schedule Inspections via Email at: [BIDScheduling@universalengineering.com](mailto:BIDScheduling@universalengineering.com)

**SCHEDULE INSPECTIONS BY 4PM CUT OFF TIME**

**Inspection Results Will Be Sent Out the Following Business Day**

**"WARNING TO OWNER: YOUR FAILURE TO RECORD A NOTICE OF COMMENCEMENT MAY RESULT IN YOUR PAYING TWICE FOR IMPROVEMENTS TO YOUR PROPERTY. IF YOU INTEND TO OBTAIN FINANCING, CONSULT WITH YOUR LENDER OR AN ATTORNEY BEFORE RECORDING YOUR NOTICE OF COMMENCEMENT."**

Window/Door	INSPECTOR	DATE	COMMENTS
900 In-Progress			
910 Final			

Inspection requests are to be emailed to [BIDScheduling@UniversalEngineering.com](mailto:BIDScheduling@UniversalEngineering.com); a confirmation email will be sent back to you upon scheduling. **Next-Day Inspection requests must be made by 4pm.** Please include the following in your request: Permit #, project address, type of inspection, date of the requested inspection, a contact name & a contact phone number. AM or PM may be requested but cannot be guaranteed.

Prepared By J. Gooch  
Return to FASWD, LLC  
3020 Mercy Dr Orlando FL 32808

**NOTICE OF COMMENCEMENT**

State of Florida  
County of Orange  
Parcel ID: 24-23-29-3400-00-1102 Permit #: 2018-04-030

The undersigned hereby gives notice that improvement will be made to certain real property. In accordance with Chapter 713, Florida Statutes, the following information is provided in the Notice of Commencement:

- 1. Legal description of Property (and street address if available): 6201 Matchett Rd. SUB OF HARNEY HOMESTEAD C/S3 THE N 100 FT OF S 325 FT OF LOT 10 E OF MATCHETT RD & RECLAIMED LAKE. Bottom to Lake
- 2. General description of improvement: door replacement
- 3. a. Owner name/address: John Holloway 6201 Matchett Rd. Belle Isle, FL 32809  
b. Interest in property: owner  
c. Name and address of fee simple title holder (if other than owner): same
- 4. Contractor Name and Address: FASWD, LLC  
3020 MERCY DRIVE, ORLANDO, FL 32808  
Phone: 407-770-0184 Fax: 407-770-0187
- 5. Surety - Name and Address: n/a  
Amount of bond: \$ n/a
- 6. Lender - Name and Address: n/a
- 7. Persons within the State of Florida designated by Owner upon whom notices or other documents may be served as provided by Section 713.13(1)(a) 7, Florida Statutes: n/a
- 8. In addition to him/herself, Owner designates the following person(s) to receive a copy of the Lienor's Notice as provided in Section 713.13(1)(b) Florida Statutes [Provide Name/Mailing Address]: n/a
- 9. NOC expiration date (one full year from the date of recording unless different date is specified):

199437

**WARNING TO OWNER: ANY PAYMENTS MADE BY THE OWNER AFTER THE EXPIRATION OF THE NOTICE OF COMMENCEMENT ARE CONSIDERED IMPROPER PAYMENTS UNDER CHAPTER 713, PART I, SECTION 713.13, FLORIDA STATUTES, AND CAN RESULT IN YOUR PAYING TWICE FOR IMPROVEMENTS TO YOUR PROPERTY. A NOTICE OF COMMENCEMENT MUST BE RECORDED AND POSTED ON THE JOB SITE BEFORE THE FIRST INSPECTION. IF YOU INTEND TO OBTAIN FINANCING, CONSULT WITH YOUR LENDER OR AN ATTORNEY BEFORE COMMENCING WORK OR RECORDING YOUR NOTICE OF COMMENCEMENT.**

Verification pursuant to Section 92.525, Florida Statutes: Under penalties of perjury, I declare that I have read the foregoing and that the facts stated in it are true to the best of my knowledge and belief.

[Signature]  
Signature of Owner (A Natural Person) (or Owner's Authorized Officer, Director, Partner, Manager)

The foregoing instrument was acknowledged before me this 27 day of March, 2018  
by John Holloway (print name of person) as owner (type of authority) for SELF (name of party on behalf of whom instrument was executed)

[Signature]  
Notary Public Personally Known  OR Produced Identification



Prepared By J. Gooch  
Return to FASWD, LLC  
3020 Mercy Dr Orlando FL 32808

DOC # 20180212124  
04/10/2018 08:56 AM Page 1 of 1  
Rec Fee: \$10.00  
Deed Doc Tax: \$0.00  
Mortgage Doc Tax: \$0.00  
Intangible Tax: \$0.00  
Phil Diamond, Comptroller  
Orange County, FL  
Ret To: SIMPLIFILE LC

### NOTICE OF COMMENCEMENT

State of Florida  
County of Orange  
Parcel ID: 24-23-29-3400-00-162 Permt #:

The undersigned hereby gives notice that improvement will be made to certain real property. In accordance with Chapter 713, Florida Statutes, the following information is provided in the Notice of Commencement:

1. Legal description of Property (and street address if available): 6201 Matchett Rd. SUB OF HARNEY HOMESTEAD C/53 THE N 100 FT. OF S 325 FT. OF LOT 10 E OF MATCHETT RD & RECLAIMED LAKE. BOTTOM TO LAKE
2. General description of improvement: door replacement
- 3 a. Owner name/address: John Holloway 6201 Matchett Rd. Belle Isle, FL 32809  
b. Interest in property: owner  
c. Name and address of fee simple title holder (if other than owner): same

199437

4. Contractor Name and Address: FASWD, LLC  
3020 MERCY DRIVE ORLANDO, FL 32808  
Phone: 407-770-0184 Fax: 407-770-0187

5. Surety - Name and Address: n/a  
Amount of bond: \$

6. Lender - Name and Address: n/a

7. Persons within the State of Florida designated by Owner upon whom notices or other documents may be served as provided by Section 713.13(1)(a) 7, Florida Statutes: n/a

8. In addition to him/herself, Owner designates the following person(s) to receive a copy of the Lienor's Notice as provided in Section 713.13(1)(b) Florida Statutes [Provide Name/Mailing Address]:  
n/a

9. NOC expiration date (one full year from the date of recording unless different date is specified):

**WARNING TO OWNER: ANY PAYMENTS MADE BY THE OWNER AFTER THE EXPIRATION OF THE NOTICE OF COMMENCEMENT ARE CONSIDERED IMPROPER PAYMENTS UNDER CHAPTER 713, PART I, SECTION 713.13, FLORIDA STATUTES, AND CAN RESULT IN YOUR PAYING TWICE FOR IMPROVEMENTS TO YOUR PROPERTY. A NOTICE OF COMMENCEMENT MUST BE RECORDED AND POSTED ON THE JOB SITE BEFORE THE FIRST INSPECTION. IF YOU INTEND TO OBTAIN FINANCING, CONSULT WITH YOUR LENDER OR AN ATTORNEY BEFORE COMMENCING WORK OR RECORDING YOUR NOTICE OF COMMENCEMENT.**

Verification pursuant to Section 92.525, Florida Statutes: Under penalties of perjury, I declare that I have read the foregoing and that the facts stated in it are true to the best of my knowledge and belief.

[Signature]  
Signature of Owner/A Natural Person (or Owner's Authorized Officer/Director/Partner/Manager)

The foregoing instrument was acknowledged before me this 27 day of March 2018  
by John Holloway (print name of person) as owner (type of authority) for SELF (name of party on behalf of whom instrument was executed)

[Signature]  
Notary Public Personally Known  -OR- Produced Identification



LIMITED POWER OF ATTORNEY

Date: 4/9/18

I hereby name and appoint Jeanne Young & Jennifer Gooch to be my lawful attorney-in-fact to act for me and apply for a building permit for work to be performed at the location described as:

6201 Matchwood.

(Address of Job)

John Holloway

(Owner of Property)

And to sign my name and do all things necessary to this appointment.

[Signature]  
Signature of Certified Contractor

Scott A. Varga (CGC1518212)  
Printed Name of Contractor and License Number

STATE OF FLORIDA  
COUNTY OF Orange

The foregoing instrument was acknowledged before me this 9 day of April, 2018, by Scott A. Varga who is  personally known to me or  has produced \_\_\_\_\_ (type of identification) has identification.

[Signature]  
Signature of Notary Public, State of Florida

Suzanne Baltzley  
Print/Type/Stamp Name of Notary Public

(SEAL)



Job ID: 195 Customer: Holloway, John Address: 6201 Matchett Rd. Belle Isle Fl. 32809 Sales Rep: S. Urbina  
 199437 DONT FORGET \*Mean Roof Height \*Corner \*Room IDs

No.	Type	DP	Size	SHGC	U-Factor
1	XXO' SG-D.	115/100	116" x 80"	.21	.63
2	XO' SG-D.	115/100	71" x 80"	.21	.63
3			X		
4			X		
5			X		
6			X		
7			X		
8			X		
9			X		
10			X		
11			X		
12			X		
13			X		
14			X		
15			X		
16			X		
17			X		
18			X		
19			X		
20			X		
21			X		
22			X		
23			X		
24			X		
25			X		

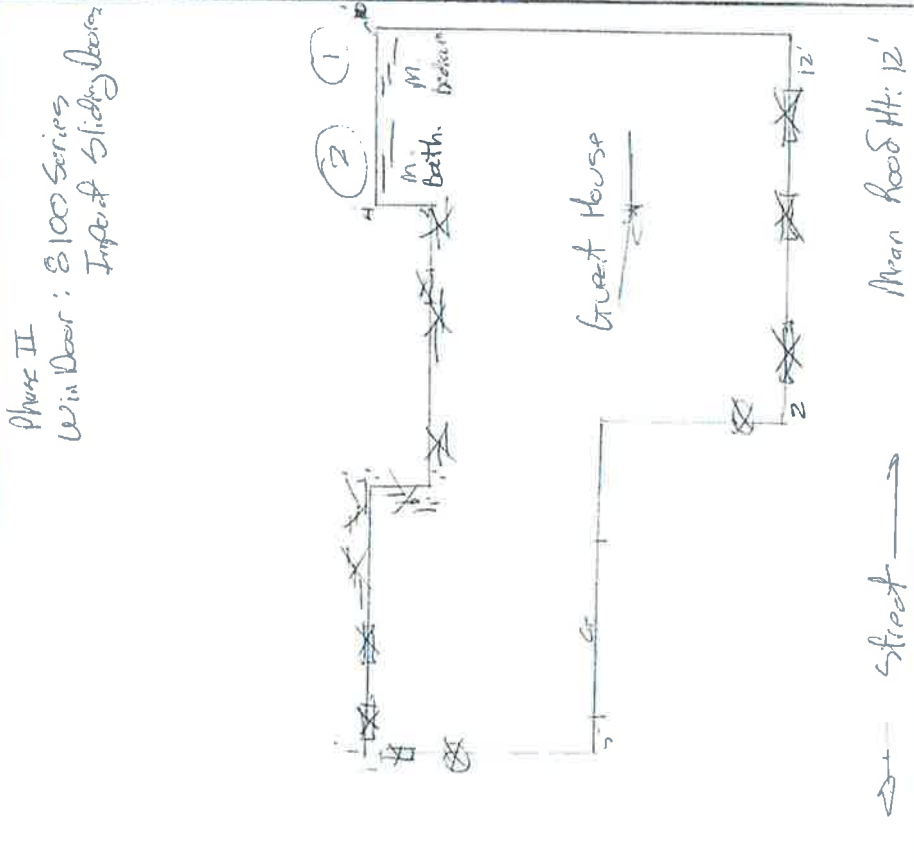



**STATE OF FLORIDA  
DEPARTMENT OF BUSINESS AND PROFESSIONAL REGULATION**

**CONSTRUCTION INDUSTRY LICENSING BOARD  
1940 NORTH MONROE STREET  
TALLAHASSEE FL 32399-0783**

**(850) 487-1395**

**MILLER, DALLAS LEE  
D & D GARAGE DOORS INC  
1177 CATTLEMAN ROAD  
SARASOTA FL 34232**

Congratulations! With this license you become one of the nearly one million Floridians licensed by the Department of Business and Professional Regulation. Our professionals and businesses range from architects to yacht brokers, from boxers to barbeque restaurants, and they keep Florida's economy strong.

Every day we work to improve the way we do business in order to serve you better. For information about our services, please log onto [www.myfloridalicense.com](http://www.myfloridalicense.com). There you can find more information about our divisions and the regulations that impact you, subscribe to department newsletters and learn more about the Department's initiatives.

Our mission at the Department is: License Efficiently, Regulate Fairly. We constantly strive to serve you better so that you can serve your customers. Thank you for doing business in Florida, and congratulations on your new license!



DETACH HERE

RICK SCOTT, GOVERNOR

KEN LAWSON, SECRETARY

**STATE OF FLORIDA  
DEPARTMENT OF BUSINESS AND PROFESSIONAL REGULATION  
CONSTRUCTION INDUSTRY LICENSING BOARD**

<b>LICENSE NUMBER</b>	
CBC1258205	

The **BUILDING CONTRACTOR**  
Named below IS CERTIFIED  
Under the provisions of Chapter 489 FS.  
Expiration date: AUG 31, 2018



**MILLER, DALLAS LEE  
D & D GARAGE DOORS INC  
1177 CATTLEMAN ROAD  
SARASOTA FL 34232**











*Bloch*  
Sign up for e-Notify.

- [Searches](#)
- [Sales Search](#)
- [Results](#)
- [Property Record Card](#)
- [My Favorites](#)

**6201 Matchett Rd** < 24-23-29-3400-00-162 >

Name: Holloway John W Life Estate  
 Rem: John W Holloway Homestead Trust  
 Mailing Address On File: 6201 Matchett Rd  
 Belle Isle, FL 32809-5147  
 Incorrect Mailing Address?

Parcel ID: 24-23-29-3400-00-162  
 6201 Matchett Rd  
 Postal City and Zip Code: Orlando, FL 32809  
 Property Class: 0130 - Sfr - Lake Front  
 Municipality: Belle Isle



**View 2017 Property Record Card**

- [Property Features](#)
- [Values, Exemptions and Taxes](#)
- [Sales Analysis](#)
- [Location Info](#)
- [Market Stats](#)
- [Update Information](#)

**2018 values will be available in August of 2018.**

**Property Description**

[View Plat](#)

SUB OF HARNEY HOMESTEAD C/53 THE N 160 FT OF S 325 FT OF LOT 16 E OF MATCHETT RD & RECLAIMED LAKE BOTTOM TO LAKE

**Total Land Area** 124,286 sqft (+/-) | 2.85 acres (+/-) GIS Calculated Notice

**Land**

Land Use Code	Zoning	Land Units	Unit Price	Land Value	Class Unit Price	Class Value
0130 - Sfr - Lake Front	R-1-AA	1 LOT(S)	working...	working...	working...	working...

Page 1 of 1 (1 total records)

**Buildings**

Important Information		Structure			
	<b>Model Code:</b> 01 - Single Fam Residence	<b>Actual Year Built:</b> 1956	<b>Gross Area:</b> 6260 sqft		
	<b>Type Code:</b> 0103 - Single Fam Class III	<b>Beds:</b> 4	<b>Living Area:</b> 5387 sqft		
	<b>Building Value:</b> working...	<b>Baths:</b> 3.5	<b>Exterior Wall:</b> Concrete Block Stucco		
	<b>Estimated New Cost:</b> working...	<b>Floors:</b> 1	<b>Interior Wall:</b> Drywall		

Page 1 of 1 (1 total records)

**Extra Features**

Description	Date Built	Units	XFOB Value
FPL3 - Good Fireplace	01/01/1956	1 Unit(s)	working...
BH2 - Boat House 2	01/01/1956	1 Unit(s)	working...
PL1 - Typical 0100 Pool	01/01/1980	1 Unit(s)	working...
PT3 - Patio 3	01/01/1996	1 Unit(s)	working...
BC2 - Boat Cover 2	01/01/1996	1 Unit(s)	working...
SPA2 - Spa 2	01/01/2002	1 Unit(s)	working...
BD2 - Boat Dock 2	01/01/2002	1 Unit(s)	working...

Page 1 of 1 (7 total records)

This Data Printed on 04/04/2018 and System Data Last Refreshed on 04/03/2018

ACORD™

Client#: 1409420 131FASWIN
CERTIFICATE OF LIABILITY INSURANCE

DATE (MM/DD/YYYY)
4/12/2017

THIS CERTIFICATE IS ISSUED AS A MATTER OF INFORMATION ONLY AND CONFERS NO RIGHTS UPON THE CERTIFICATE HOLDER. THIS CERTIFICATE DOES NOT AFFIRMATIVELY OR NEGATIVELY AMEND, EXTEND OR ALTER THE COVERAGE AFFORDED BY THE POLICIES BELOW.

IMPORTANT: If the certificate holder is an ADDITIONAL INSURED, the policy(ies) must be endorsed. If SUBROGATION IS WAIVED, subject to the terms and conditions of the policy, certain policies may require an endorsement.

PRODUCER
BB&T Insurance Services, Inc.
PO Box 4927
Orlando, FL 32802-4927
407 691-9600

CONTACT NAME:
PHONE (A/C, No., Ext): 407 691-9600
FAX (A/C, No.): 888-635-4183
E-MAIL ADDRESS:

Table with columns: INSURER(S) AFFORDING COVERAGE, NAIC #. Rows include Gemini Insurance Company (10833), Evanston Insurance Company (35378), and Amerisure Insurance Company (19488).

INSURED
FASWD LLC dba FAS Windows & Doors
and dba FAS Exteriors
3020 Mercy Drive
Orlando, FL 32808

COVERAGES CERTIFICATE NUMBER: 17/18 Master BAI REVISION NUMBER:

THIS IS TO CERTIFY THAT THE POLICIES OF INSURANCE LISTED BELOW HAVE BEEN ISSUED TO THE INSURED NAMED ABOVE FOR THE POLICY PERIOD INDICATED. NOTWITHSTANDING ANY REQUIREMENT, TERM OR CONDITION OF ANY CONTRACT OR OTHER DOCUMENT WITH RESPECT TO WHICH THIS CERTIFICATION MAY BE ISSUED OR MAY PERTAIN, THE INSURANCE AFFORDED BY THE POLICIES DESCRIBED HEREIN IS SUBJECT TO ALL THE TERMS, EXCLUSIONS AND CONDITIONS OF SUCH POLICIES. LIMITS SHOWN MAY HAVE BEEN REDUCED BY PAID CLAIMS.

Main table with columns: INSR LTR, TYPE OF INSURANCE, ADDL SUBR INSR, WVO, POLICY NUMBER, POLICY EFF, POLICY EXP, LIMITS. Includes sections for Commercial General Liability, Automobile Liability, Umbrella Liability, and Workers Compensation.

DESCRIPTION OF OPERATIONS / LOCATIONS / VEHICLES (ACORD 101, Additional Remarks Schedule, may be attached if more space is required)
\*Additional insured status is granted with respects to General Liability if required by written contract per endorsement "Additional Insured-Owners, Lessees or Contractors-Scheduled Person or Organization" form #CG2010 04 13 and "Additional Insured-Owners, Lessees or Contractors-Completed Operations", form #CG2037 04 13.
(See Attached Descriptions)

CERTIFICATE HOLDER
City of Belle Isle
1600 Nela Avenue
Belle Isle, FL 32809

CANCELLATION
SHOULD ANY OF THE ABOVE DESCRIBED POLICIES BE CANCELLED BEFORE THE EXPIRATION DATE THEREOF, NOTICE WILL BE DELIVERED IN ACCORDANCE WITH THE POLICY PROVISIONS.
AUTHORIZED REPRESENTATIVE

3020 Merex Drive  
Orlando, FL 32808  
(407)70-0184

Call  
407-257-9345



199437  
Jesse  
7711 Anderson Rd.  
Lampa, FL 33634  
(813)514-9490

Name: John + Diana Holloway (407) 257-4912 (407) 440-0013  
I, We, the owners of the premises described below, having referred to as "Buyer" offer to contract with FAS Windows & Doors, hereinafter referred to as "FASWD", to furnish all materials listed below for use at the premises located at:

60201 Matchett Rd. Belle Isle Fl. 32809.

Congratulations on your purchase of the finest home improvement products in the industry today! Below are the names and contact information of key people involved with your purchase. We believe that communication is the pathway to success! Please contact the people below at any time regarding your purchase and/or installation.

**Installation**

You will be contacted by a member of your Installation Team to discuss the following:

1. Confirm receipt of your contract and review specifications
2. Schedule a time for the tight measure.
3. Identify an approximate installation start or delivery date
4. Answer any concerns you may have related to the project

**Customer Care**

In the event that you have any questions or concerns regarding the window or door installation, please do not hesitate to contact Scott, your Production Coordinator, or Tony or Suzie, your Production Manager, at Terry. If you feel that we did not deliver on any of our promises to you, please contact us at \_\_\_\_\_

Install  Pick Up  Delivery  Level  Mixal  Supply  Mixed

Quantity	Manufacturer	Series	Style	Color	Grids	Screen	Observe Tempco	Life Note
1	Lea Window	8100	56.0" x 80"	Bronze glum	—	—	(P)	1" Impact Glass / 5070 x 6. 2605 Fin. Sh.
2	Lea Window	8100	56.0" x 80"	Bronze glum	—	—	(P)	1" Impact Glass / 5070 x 6. 2605 Fin. Sh.
3								
4								

\*Please note all grid specifications, finish, hardware, screen and hinge details in line notes

**Special Instructions:**

Call Discounts Applied.  
contemporary/modern hardware

Please read the following bold type and initial corresponding line.

BHI doors are non-finished. Failure to paint or stain doors in a timely manner may affect your rights under the manufacturer's warranty.

Not Applicable

Buyer initials: NA

Verbal understandings and agreements with representative shall not be binding. All understandings and agreements must be set forth in writing in this Contract. I understand and recognize all terms and conditions on the front and reverse of this contract and am initialing to indicate my complete understanding.

Buyer initials: [Signature]

**HURRICANE PROTECTION** I acknowledge that I am the owner of the residence and have contracted with FASWD to replace windows/doors. The home is located in an Impact zone and I have existing hurricane protection equipment that complies with local jurisdiction. FASWD will not be liable if my existing protection equipment is deemed inadequate by the local government inspector after my windows are installed. In the event that my hurricane protection equipment fails inspection, I understand that FASWD will supply appropriate materials at a cost to me of \$375.00 per opening. I am initialing to indicate my complete understanding.

Not Applicable

Buyer initials: NA

NOTE: The warranty provisions as stated on the reverse have been explained and I/we understand them fully. Additional provisions and warranties are stated on the reverse side and are part of this contract.

Buyer initials: [Signature]

The TOTAL PRICE for  labor or  materials (including any applicable taxes) is \_\_\_\_\_  
Terms:  Credit Subject to the approval of the Credit Department  
 Credit Card (Please fill out credit card information sheet)

Cash/ final Payment payable to Installer upon completion

SUBTOTAL: \$18,194.

TAX (DELIVERY OR PICK UP ONLY): 00

GRAND TOTAL: \$18,194.

DEPOSIT REQUIRED: \$9,000

BALANCE DUE: \$9,194.

If this is a credit transaction, the agreement for credit is contained in a separate document which is incorporated herein by reference and made a part hereof. IN WITNESS WHEREOF Buyer(s) have hereunto signed their names) this 27 day of March, 2018 and acknowledge receipt of a true copy of this Contract and unless otherwise specified, it is understood that the Buyer is ready for work to begin.

You, the Buyer(s), may cancel this transaction at any time prior to midnight of the third day after the date of this transaction. Signature affixed below acts as a receipt that buyer(s) received appropriate cancellation notice. See reverse side for details.

FASWD  
Signature: [Signature] Date: 3/27/18

BUYER  
Signature: [Signature] Date: 3/27/18

Buyer(s) understands that this document does not constitute a valid and binding contract for any purpose unless and until it is signed and accepted by an authorized representative of FASWD. All amounts due under this agreement shall be paid upon the date specified herein, if so set out, or upon the day the last of the work or products are furnished to the Buyer. Past due amounts are subject to a service charge of 18% per annum from the due date. Buyer agrees to pay FASWD all costs of enforcement or collection, including reasonable attorney fees, whether or not a lawsuit is commenced as a part of the collection process. This Contract and the agreement for credit, if any, shall constitute the entire agreement between the parties. All terms, conditions and specifications shall not be altered or modified except by written agreement between the parties hereto.

IN THE EVENT THIS CONTRACT IS NOT ACCEPTED BY FASWD, ANY PAYMENT MADE HEREUNDER SHALL BE REFUNDED TO THE BUYER(S) AND THE CONTRACT SHALL BE NULL AND VOID AND OF NO EFFECT. FASWD IS NOT RESPONSIBLE FOR EXISTING STRUCTURAL DEFECTS, DRY ROT OR CODE VIOLATIONS, REPAIRING, PLASTERING, CARPENTRY AND OR DECORATING, ARE NOT INCLUDED UNLESS SPECIFICALLY CHARGED FOR AND SPECIFIED IN WRITING HEREIN.



# City of Belle Isle

Universal Engineering Sciences 3532 Maggie Blvd., Orlando, FL 32811  
 Tel 407-581-8161 \* Fax 407-581-0313 \* [www.universalengineering.com](http://www.universalengineering.com)

## Product Approval Form

DATE: 4/9/18

PERMIT # 2018-04-030

PROJECT ADDRESS 6201 Matchett Rd

Belle Isle, FL  32809  32812

As required by Florida Statute 553.842 and Florida Administrative Code 9B-72m, please provide the information and approval numbers of the building components listed below if they will be utilized on the building or structure. FL Approved products are listed online at [www.floridabuilding.org](http://www.floridabuilding.org) or can be obtained from the local product supplier. The following information must be turned in with permit application and available onsite for inspections:

1. This Product Approval Cover Sheet
2. Internet screen from FloridaBuilding.org showing PA#, approval and code edition stamped
3. Manufacturer's installation details from FloridaBuilding.org and requirements for each product stamped

Product Type	Manufacturer	Model/Series	FL Product Approval #	Product Type	Manufacturer	Model/Series	FL Product Approval #
<b>EXTERIOR DOORS</b>				<b>WALL PANELS</b>			
Swinging				Sliding			
Sliding	WINDOOR	8100	12979.4	Soffits			
Sectional/Rollup				Storefront			
Other				Glass Block			
				Other			
<b>WINDOWS</b>				<b>ROOFING PRODUCTS</b>			
Single/Dbf Hung				Asphalt Shingles			
Horizontal Slider				Non Struct Metal			
Casement				Roofing Tiles			
Fixed				Single Ply Roof			
Mullion				Underlayment			
Skylights				Other			
Other							
<b>STRUCTURAL COMPONENTS</b>				<b>OTHER</b>			
Wood Connectors							
Wood Anchors							
Truss Plates							
Insulation Forms							
Lintels							
Other							

It is the applicant's responsibility to verify that specific products have been installed in accordance with their limitations and with the minimum required design pressures for the structure. Specific compliance will be verified during field inspections.

Applicant Signature

Date 4/9/18

Sections from the Code

Product Approval Method Method 1 Option D

Date Submitted 02/05/2018

Date Validated 02/05/2018

Date Pending FBC Approval 02/15/2018

**Summary of Products**

FL #	Model, Number or Name	Description
12979.1	8100 SERIES	8100 SERIES ALUMINUM 90D CORNER SGD W AND W/OUT REINFORCEMENT NON-IMPACT
<b>Limits of Use</b> <b>Approved for use in HVHZ:</b> No <b>Approved for use outside HVHZ:</b> Yes <b>Impact Resistant:</b> No <b>Design Pressure:</b> N/A <b>Other:</b> REFER TO APPROVAL DOCUMENT FOR DESIGN PRESSURE RATINGS		<b>Installation Instructions</b> <a href="#">FL12979 R6 II 08-00825B.pdf</a> Verified By: Luis Roberto Lomas 62514 Created by Independent Third Party: Yes <b>Evaluation Reports</b> <a href="#">FL12979 R6 AE 511367B.pdf</a> Created by Independent Third Party: Yes
12979.2	8100 SERIES	8100 SERIES ALUMINUM 135D CORNER SGD W AND W/OUT REINFORCEMENT NON-IMPACT
<b>Limits of Use</b> <b>Approved for use in HVHZ:</b> No <b>Approved for use outside HVHZ:</b> Yes <b>Impact Resistant:</b> No <b>Design Pressure:</b> N/A <b>Other:</b> REFER TO APPROVAL DOCUMENT FOR DESIGN PRESSURE RATINGS		<b>Installation Instructions</b> <a href="#">FL12979 R6 II 08-00826B.pdf</a> Verified By: Luis Roberto Lomas 62514 Created by Independent Third Party: Yes <b>Evaluation Reports</b> <a href="#">FL12979 R6 AE 511368B.pdf</a> Created by Independent Third Party: Yes
12979.3	8100 SERIES	8100 SERIES REINFORCED ALUMINUM SGD 90DEGREE, 135 DEGREE AND BYPASS LMI
<b>Limits of Use</b> <b>Approved for use in HVHZ:</b> Yes <b>Approved for use outside HVHZ:</b> Yes <b>Impact Resistant:</b> Yes <b>Design Pressure:</b> N/A <b>Other:</b> REFER TO APPROVAL DOCUMENT FOR DESIGN PRESSURE RATINGS. GLAZING INTERLAYER MEET THE REQUIREMENTS OF THE FLORIDA BUILDING CODE ACCORDING TO MIAMI-DADE NOA FOR KURARAY AND EASTMAN INTERLAYERS.		<b>Installation Instructions</b> <a href="#">FL12979 R6 II 08-01167C.pdf</a> Verified By: Luis Roberto Lomas 62514 Created by Independent Third Party: Yes <b>Evaluation Reports</b> <a href="#">FL12979 R6 AE 511738C.pdf</a> Created by Independent Third Party: Yes
12979.4	8100 SERIES	8100 SERIES NON REINFORCED ALUMINUM SGD 90DEGREE, 135 DEGREE AND BYPASS LMI
<b>Limits of Use</b> <b>Approved for use in HVHZ:</b> Yes <b>Approved for use outside HVHZ:</b> Yes <b>Impact Resistant:</b> Yes <b>Design Pressure:</b> N/A <b>Other:</b> REFER TO APPROVAL DOCUMENT FOR DESIGN PRESSURE RATINGS. GLAZING INTERLAYER MEET THE REQUIREMENTS OF THE FLORIDA BUILDING CODE ACCORDING TO MIAMI-DADE NOA FOR KURARAY AND EASTMAN INTERLAYERS.		<b>Installation Instructions</b> <a href="#">FL12979 R6 II 08-01168C.pdf</a> Verified By: Luis Roberto Lomas 62514 Created by Independent Third Party: Yes <b>Evaluation Reports</b> <a href="#">FL12979 R6 AE 511739C.pdf</a> Created by Independent Third Party: Yes
12979.5	8100 SERIES	8100 SERIES REINFORCED ALUMINUM SGD 90DEGREE, 135DEGREE CORNER AND BYPASS NON-IMPACT, 12' PANEL.
<b>Limits of Use</b> <b>Approved for use in HVHZ:</b> No <b>Approved for use outside HVHZ:</b> Yes <b>Impact Resistant:</b> No <b>Design Pressure:</b> N/A <b>Other:</b> REFER TO APPROVAL DOCUMENT FOR DESIGN PRESSURE RATINGS		<b>Installation Instructions</b> <a href="#">FL12979 R6 II 08-01259A .pdf</a> Verified By: Luis Roberto Lomas 62514 Created by Independent Third Party: Yes <b>Evaluation Reports</b> <a href="#">FL12979 R6 AE 511861A.pdf</a> Created by Independent Third Party: Yes

[Back](#) [Next](#)

Contact Us :: 2601 Blair Stone Road, Tallahassee FL 32399 Phone: 850-487-1824



BCIS Home Log In User Registration Hot Topics Submit Surcharge Stats & Facts Publications FBC Staff BCIS Site Map Links Search



**Product Approval**  
USER: Public User

[Product Approval Menu](#) > [Product or Application Search](#) > [Application List](#) > [Application Detail](#)



FL #	FL12979-R6														
Application Type	Revision														
Code Version	2017														
Application Status	Pending FBC Approval														
Comments	conditional approval.. April cycle 2018..														
Archived	<input type="checkbox"/>														
Product Manufacturer	Windoor Incorporated														
Address/Phone/Email	7500 Amsterdam Dr. Orlando, FL 32832 (407) 481-8400 vvalentin@windoorinc.com														
Authorized Signature	Volker Valentin vvalentin@windoorinc.com														
Technical Representative	Volker Valentin														
Address/Phone/Email	7500 Amsterdam Drive Orlando, FL 32832 (407) 481-8400 vvalentin@windoorinc.com														
Quality Assurance Representative															
Address/Phone/Email															
Category	Exterior Doors														
Subcategory	Sliding Exterior Door Assemblies														
Compliance Method	Evaluation Report from a Florida Registered Architect or a Licensed Florida Professional Engineer <input type="checkbox"/> Evaluation Report - Hardcopy Received														
Florida Engineer or Architect Name who developed the Evaluation Report	Luis Roberto Lomas														
Florida License	PE-62514														
Quality Assurance Entity	Keystone Certifications, Inc.														
Quality Assurance Contract Expiration Date	08/01/2023														
Validated By	Steven M. Urlich, PE <input checked="" type="checkbox"/> Validation Checklist - Hardcopy Received														
Certificate of Independence	<a href="#">FL12979_R6_COI_FLCOI.pdf</a>														
Referenced Standard and Year (of Standard)	<table border="0"> <thead> <tr> <th><b>Standard</b></th> <th><b>Year</b></th> </tr> </thead> <tbody> <tr> <td>AAMA/WDMA/CSA 101/IS2/A440</td> <td>2005</td> </tr> <tr> <td>ASTM E1886</td> <td>2005</td> </tr> <tr> <td>ASTM E1996</td> <td>2005</td> </tr> <tr> <td>TAS 201</td> <td>1994</td> </tr> <tr> <td>TAS 202</td> <td>1994</td> </tr> <tr> <td>TAS 203</td> <td>1994</td> </tr> </tbody> </table>	<b>Standard</b>	<b>Year</b>	AAMA/WDMA/CSA 101/IS2/A440	2005	ASTM E1886	2005	ASTM E1996	2005	TAS 201	1994	TAS 202	1994	TAS 203	1994
<b>Standard</b>	<b>Year</b>														
AAMA/WDMA/CSA 101/IS2/A440	2005														
ASTM E1886	2005														
ASTM E1996	2005														
TAS 201	1994														
TAS 202	1994														
TAS 203	1994														
Equivalence of Product Standards Certified By															

REVISIONS			
REV	DESCRIPTION	DATE	APPROVED
A	REVISED NOTES	10/31/11	R.L.
B	ADDED 5T	02/14/17	R.L.
C	REVISED PER NEW REQUIREMENTS	02/01/18	R.L.

NOTES:

- 1) THE PRODUCT SHOWN HEREIN IS DESIGNED AND MANUFACTURED TO COMPLY WITH REQUIREMENTS OF THE FLORIDA BUILDING CODE INCLUDING THE HVHZ.
- 2) WOOD FRAMING AND MASONRY OPENING TO BE DESIGNED AND ANCHORED TO PROPERLY TRANSFER ALL LOADS TO STRUCTURE. FRAMING AND MASONRY OPENING IS THE RESPONSIBILITY OF THE ARCHITECT OR ENGINEER OF RECORD.
- 3) 1X BUCK OVER MASONRY/CONCRETE IS OPTIONAL. WHERE 1X BUCK IS NOT USED DISSIMILAR MATERIALS MUST BE SEPARATED WITH APPROVED COATING OR MEMBRANE. SELECTION OF COATING OR MEMBRANE IS THE RESPONSIBILITY OF THE ARCHITECT OR ENGINEER OF RECORD.
- 4) ALLOWABLE STRESS INCREASE OF 1/3 WAS NOT USED IN THE DESIGN OF THE PRODUCT SHOWN HEREIN. WIND LOAD DURATION FACTOR Cd=1.6 WAS USED FOR WOOD ANCHOR CALCULATIONS.
- 5) FRAME AND PANEL MATERIAL: EXTRUDED ALUMINUM 6063-T6.
- 6) UNITS MUST BE GLAZED PER ASTM E1300-04. SEE SHEET 14 FOR GLAZING DETAILS.
- 7) APPROVED IMPACT PROTECTIVE SYSTEM IS NOT REQUIRED FOR THIS PRODUCT IN WIND BORNE DEBRIS REGIONS.
- 8) MAXIMUM D.L.O. SIZE: 52 1/4" x 109 3/16" (STD. BOTTOM RAIL) OR 105 3/32" (TALL BOTTOM RAIL).

PANEL CONSTRUCTION:

ALL PANELS ARE CONSTRUCTED FROM EXTRUDED 6063-T6 ALUMINUM. VERTICAL STILES ARE NOTCHED TO RECEIVE HORIZONTAL RAILS. EACH RAIL IS SECURED TO STILES WITH (3) #10 x 1 1/4" SQ. DRIVE SCREW AT EACH END. ALL PANELS HAVE AN INTERIOR AND EXTERIOR APPLIED GLAZING STOP.

FRAME CONSTRUCTION:

EACH FRAME CORNER IS NOTCHED AND BUTTED. HEAD AND SILL ARE SECURED TO JAMBS WITH #7 TYPE A SS SCREW, (2) AT EACH CORNER ON 2 TRACK, (2) AT 3 TRACK FRAME, (3) AT EACH CORNER ON 4 TRACK FRAME AND (3) AT EACH CORNER ON 5 TRACK FRAME.

ANCHORING NOTES:

- 1) SHIM AS REQUIRED AT EACH INSTALLATION ANCHOR WITH LOAD BEARING SHIM. SHIM WHERE SPACE OF 1/16" OR GREATER OCCURS. MAXIMUM ALLOWABLE SHIM STACK TO BE 1/4".
- 2) FOR ANCHORING INTO MASONRY USE 1/4" ELCO CRETE-FLEX WITH SUFFICIENT LENGTH TO ACHIEVE A 1 1/4" MINIMUM EMBEDMENT INTO SUBSTRATE WITH 1 1/2" MINIMUM EDGE DISTANCE. LOCATE ANCHORS AS SHOWN IN ELEVATIONS AND INSTALLATION DETAILS.
- 3) FOR ANCHORING INTO WOOD FRAMING, USE #14 WOOD SCREW WITH SUFFICIENT LENGTH TO ACHIEVE A 1 3/8" MINIMUM EMBEDMENT INTO SUBSTRATE WITH 5/8" MINIMUM EDGE DISTANCE. LOCATE ANCHORS AS SHOWN IN ELEVATIONS AND INSTALLATION DETAILS.
- 4) FOR ANCHORING INTO METAL STRUCTURE USE #14 SMS OR SELF DRILLING SCREWS WITH SUFFICIENT LENGTH TO ACHIEVE 3 THREADS MINIMUM BEYOND STRUCTURE INTERIOR WALL. LOCATE ANCHORS AS SHOWN IN ELEVATIONS AND INSTALLATION DETAILS.
- 5) ALL FASTENERS TO BE CORROSION RESISTANT.
- 6) INSTALLATION ANCHORS SHALL BE INSTALLED IN ACCORDANCE WITH ANCHOR MANUFACTURER'S INSTALLATION INSTRUCTIONS, AND ANCHORS SHALL NOT BE USED IN SUBSTRATES WITH STRENGTHS LESS THAN THE MINIMUM STRENGTH SPECIFIED BELOW:
  - A. WOOD - MINIMUM SPECIFIC GRAVITY OF G=0.42
  - B. CONCRETE: MINIMUM COMPRESSIVE STRENGTH OF 2,000 PSI.
  - C. MASONRY: HOLLOW/FILLED BLOCK PER ASTM C90 WITH Fm=2,000PSI MINIMUM.
  - D. METAL STRUCTURE: STEEL 18GA (.048") FY=33KSI/FU=52KSI OR ALUMINUM 6063-T5 FU=30KSI .048" THICK MINIMUM

TABLE OF CONTENTS	
SHEET NO.	DESCRIPTION
1	NOTES
2	ELEVATION
3 - 5	PLAN VIEW
6	DESIGN PRESSURE CHARTS
7	ANCHORING LAYOUT
8	CLUSTER AND ANCHOR LOCATION DETAILS
9 - 12	INSTALLATION DETAILS
13	LOCKING HARDWARE LAYOUT
14	COMPONENTS & GLAZING DETAILS

**WinDoor**  
INCORPORATED

7500 AMSTERDAM DRIVE  
ORLANDO, FL 32832  
Phone: 407.481.8400  
Fax: 407.481.0505  
www.windoorinc.com

8100 SERIES NON-REINFORCED ALUMINUM SGD  
CORNER AND BYPASS (5'0x10'0 PANELS) - LMI  
NOTES

DRAWN: TJH	DWG. NO. 08-01168	REV C
SCALE NTS	DATE 02/15/11	SHEET 1 OF 14

L. ROBERTO LOMAS P.E.  
1432 WOODFORD RD LEWISVILLE, NC 27023  
434-688-0609 rilomas@rlomaspe.com

SIGNED: 02/01/2018

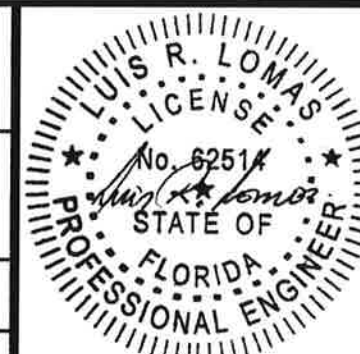

Luis R. Lomas P.E.  
FL No.: 62514



REVISIONS			
REV	DESCRIPTION	DATE	APPROVED
A	REVISED NOTES	10/31/11	R.L.
B	ADDED 5T	02/14/17	R.L.
C	REVISED PER NEW REQUIREMENTS	02/01/18	R.L.

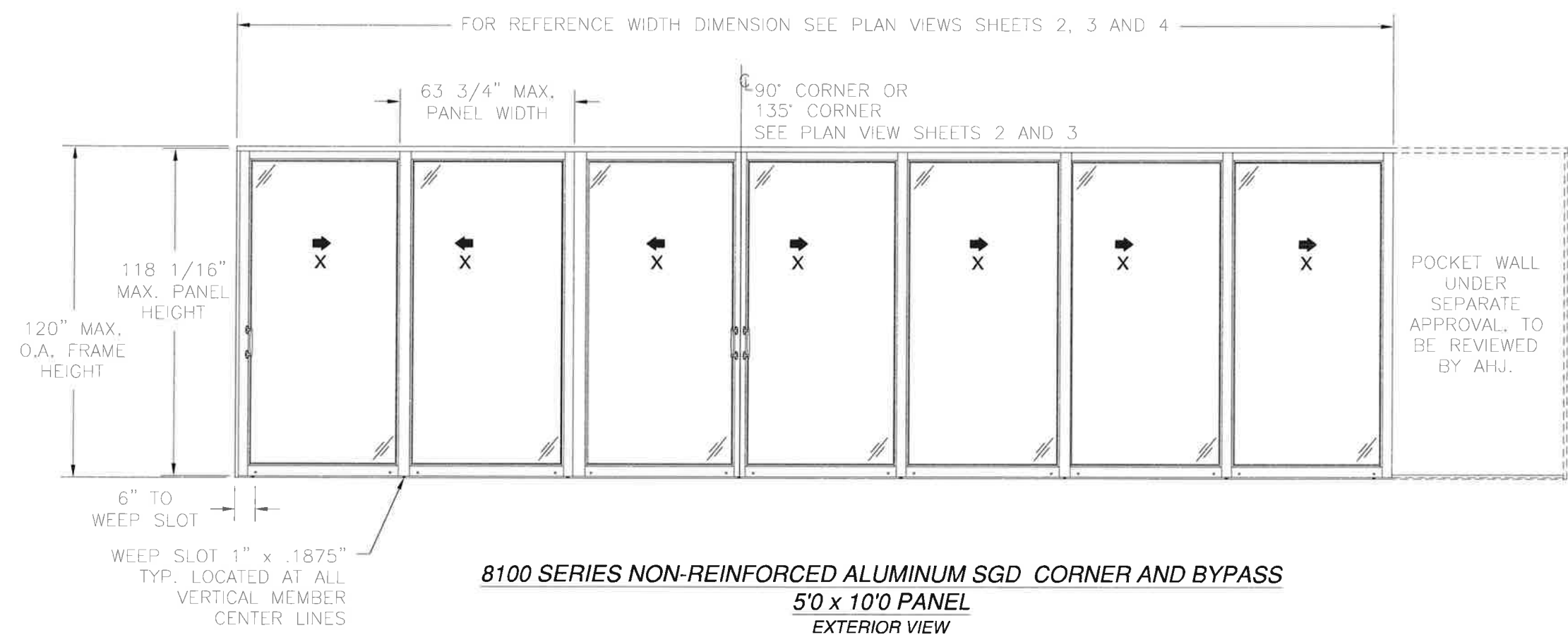

**8100 SERIES NON-REINFORCED ALUMINUM SGD CORNER AND BYPASS**  
**5'0 x 10'0 PANEL**  
**EXTERIOR VIEW**

SEVEN PANELS SHOWN. UNLIMITED NUMBER OF PANELS IN UNLIMITED CONFIGURATIONS, 90° AND 135° CORNER OR BYPASS, ON 2, 3, 4 OR 5 TRACK FRAME, WITH OR WITHOUT POCKETS, ARE APPROVED AS LONG AS INDIVIDUAL PANEL SIZE DOES NOT EXCEED MAXIMUM PANEL SIZE AND USES VERTICAL CONDITIONS AS SHOWN.

DESIGN PRESSURE RATING	IMPACT RATING
±50PSF	LARGE MISSILE IMPACT

FOR ADDITIONAL SIZES SEE SHEET 6

<b>WinDoor</b> INCORPORATED		7500 AMSTERDAM DRIVE ORLANDO, FL 32832 Phone: 407.481.8400 Fax: 407.481.0505 www.windoorinc.com	
8100 SERIES NON-REINFORCED ALUMINUM SGD CORNER AND BYPASS (5'0x10'0 PANELS) -- LMI ELEVATION			
DRAWN: TJH	DWG. NO. 08-01168	REV C	
SCALE NTS	DATE 02/15/11	SHEET 2 OF 14	
L. ROBERTO LOMAS P.E. 1432 WOODFORD RD LEWISVILLE, NC 27023 434-688-0609 rllomas@lrlomaspe.com			

SIGNED: 02/01/2018

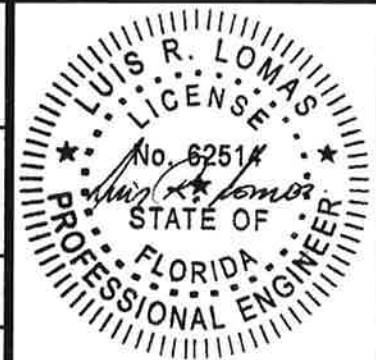

Luis R. Lomas P.E.  
FL No.: 62514

REVISIONS			
REV	DESCRIPTION	DATE	APPROVED
A	REVISED NOTES	10/31/11	R.L.
B	ADDED 5T	02/14/17	R.L.
C	REVISED PER NEW REQUIREMENTS	02/01/18	R.L.

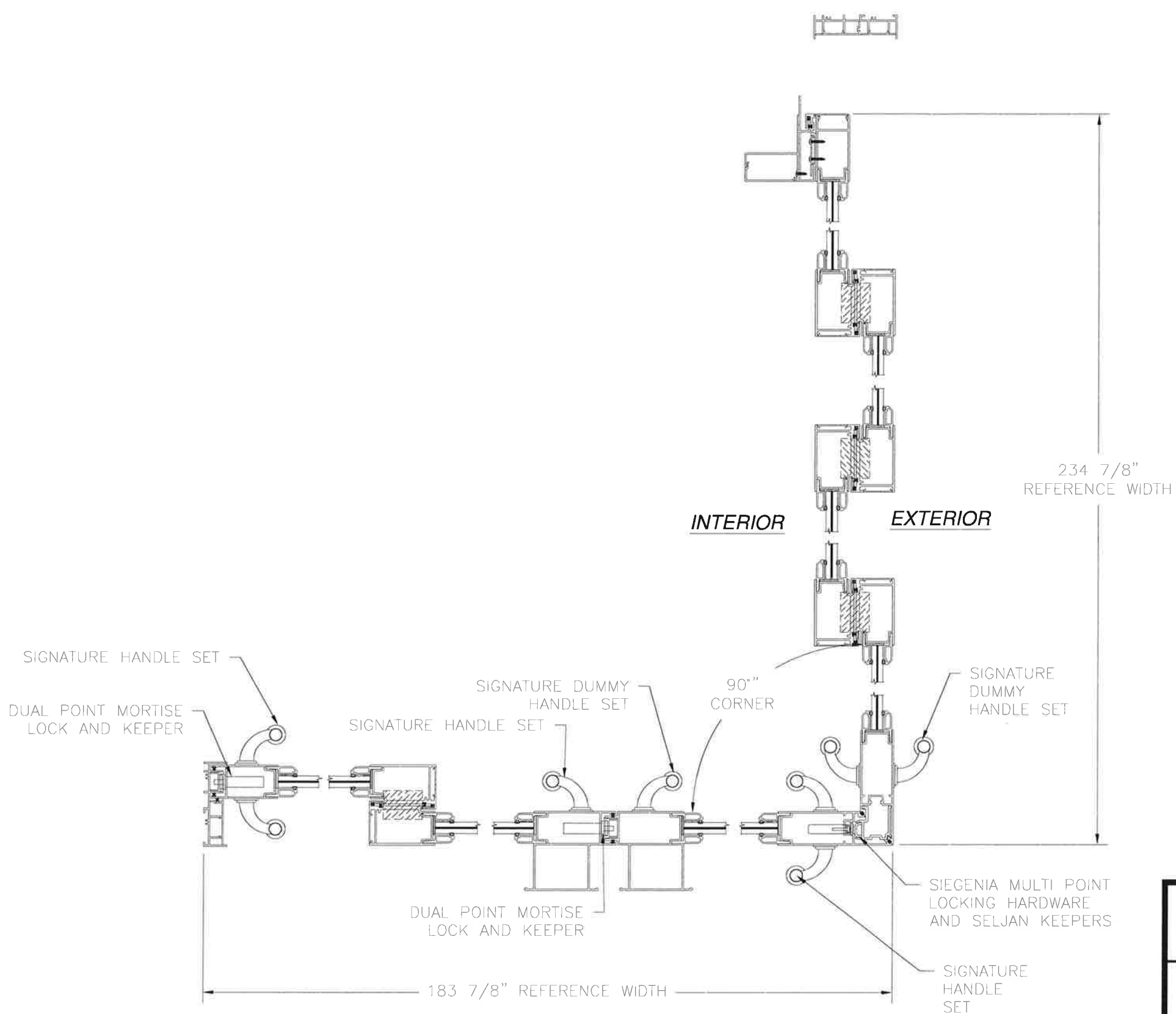

**8100 SERIES NON-REINFORCED ALUMINUM SGD 90° CORNER**  
 2TRACK LAYOUT SHOWN, 3TRACK, 4TRACK AND 5TRACK FRAME ALSO APPROVED

<b>WinDoor</b> INCORPORATED		7500 AMSTERDAM DRIVE ORLANDO, FL 32832 Phone: 407.481.8400 Fax: 407.481.0505 www.windoorinc.com	
8100 SERIES NON-REINFORCED ALUMINUM SGD CORNER AND BYPASS (5'0x10'0 PANELS) - LMI 90° CORNER PLAN VIEW			
DRAWN: TJH	DWG. NO. 08-01168	REV C	
SCALE NTS	DATE 02/15/11	SHEET 3 OF 14	
L. ROBERTO LOMAS P.E. 1432 WOODFORD RD LEWISVILLE, NC 27023 434-688-0609 rllomas@lrlomaspe.com			

SIGNED: 02/01/2018



Luis R. Lomas P.E.  
FL No.: 62514

REVISIONS			
REV	DESCRIPTION	DATE	APPROVED
A	REVISED NOTES	10/31/11	R.L.
B	ADDED 5T	02/14/17	R.L.
C	REVISED PER NEW REQUIREMENTS	02/01/18	R.L.

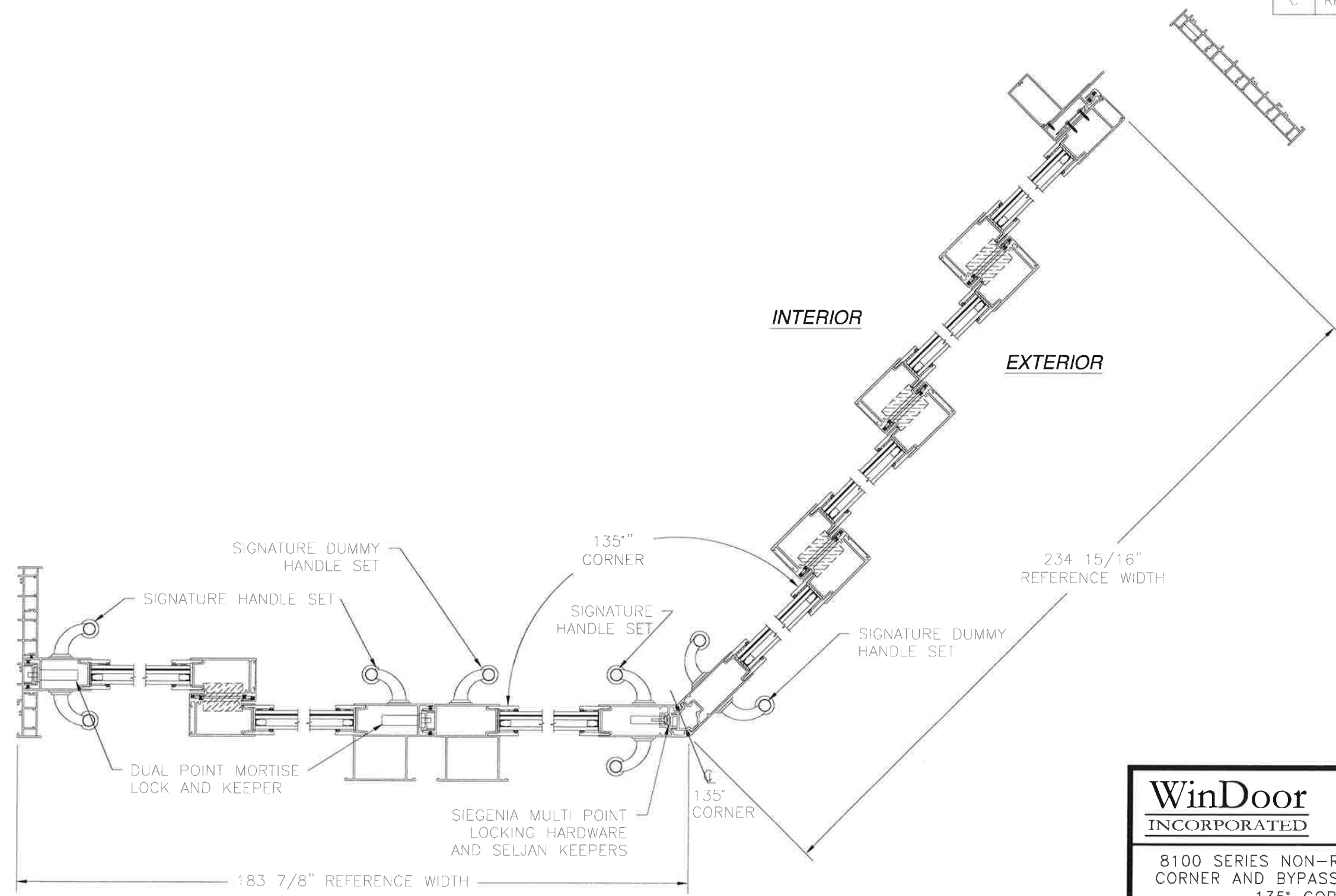

**8100 SERIES NON-REINFORCED ALUMINUM SGD 135° CORNER**  
 4TRACK LAYOUT SHOWN, 2TRACK, 3TRACK AND 5TRACK FRAME ALSO APPROVED

<b>WinDoor</b> INCORPORATED		7500 AMSTERDAM DRIVE ORLANDO, FL 32832 Phone: 407.481.8400 Fax: 407.481.0505 www.windoorinc.com
8100 SERIES NON-REINFORCED ALUMINUM SGD CORNER AND BYPASS (5'0x10'0 PANELS) - LMI 135° CORNER PLAN VIEW		
DRAWN: TJH	DWG. NO. 08-01168	REV C
SCALE NTS	DATE 02/15/11	SHEET 4 OF 14
L. ROBERTO LOMAS P.E. 1432 WOODFORD RD LEWISVILLE, NC 27023 434-688-0609 rlomas@lrloomaspe.com		

SIGNED: 02/01/2018

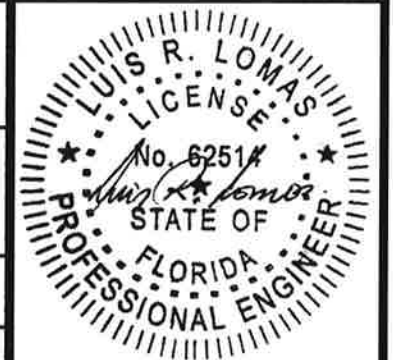

Luis R. Lomas P.E.  
FL No.: 62514

REVISIONS			
REV	DESCRIPTION	DATE	APPROVED
A	REVISED NOTES	10/31/11	R.L.
B	ADDED 5T	02/14/17	R.L.
C	REVISED PER NEW REQUIREMENTS	02/01/18	R.L.

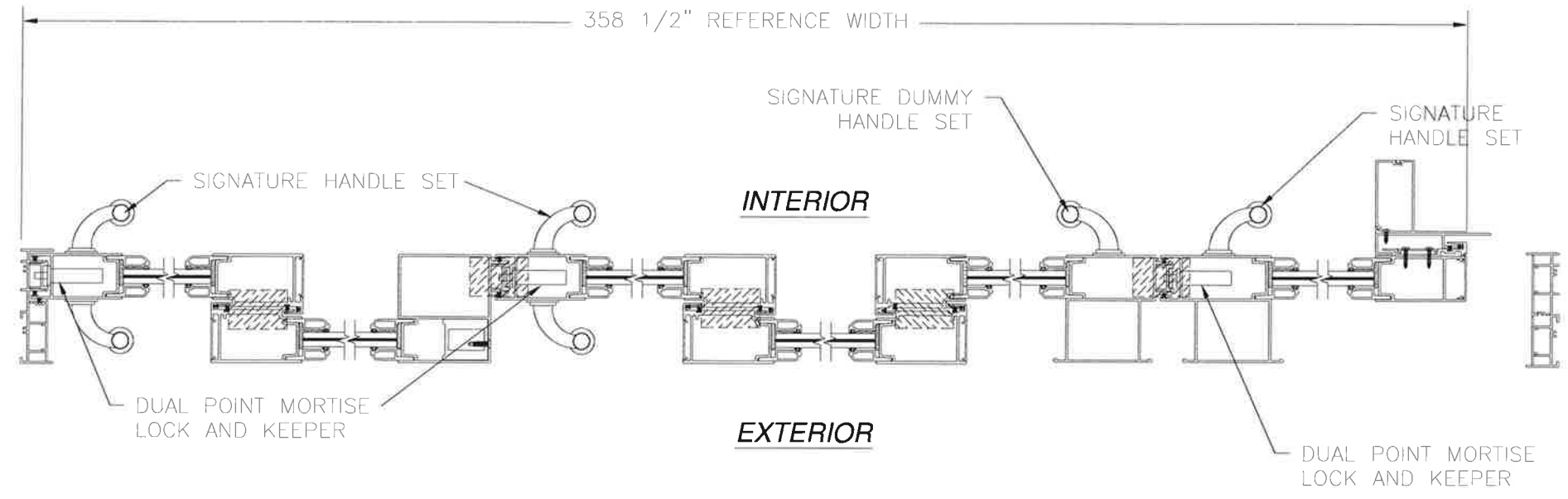

**8100 SERIES NON-REINFORCED ALUMINUM SGD BYPASS**  
 2TRACK LAYOUT SHOWN, 3TRACK, 4TRACK AND 5TRACK FRAME ALSO APPROVED

SIGNED: 02/01/2018

<b>WinDoor</b> INCORPORATED		7500 AMSTERDAM DRIVE ORLANDO, FL 32832 Phone: 407.481.8400 Fax: 407.481.0505 www.windoorinc.com	
8100 SERIES NON-REINFORCED ALUMINUM SGD CORNER AND BYPASS (5'0x10'0 PANELS) - LMI BYPASS PLAN VIEW			
DRAWN: TJH	DWG NO. 08-01168	REV C	
SCALE NTS	DATE 02/15/11	SHEET 5 OF 14	
L. ROBERTO LOMAS P.E. 1432 WOODFORD RD LEWISVILLE, NC 27023 434-688-0609 rllomas@lrlomaspe.com			



Luis R. Lomas P.E.  
FL No.: 62514

**Maximum design pressure capacity chart**

**8100 Series Non-Reinforced Aluminum SGD Corner and Bypass with 1 3/4" Riser**

Height (in)	Nominal Single Panel Width (in)													
	24.0		30.0		36.0		42.0		48.0		54.0		60.0	
	Pos	Neg	Pos	Neg	Pos	Neg	Pos	Neg	Pos	Neg	Pos	Neg	Pos	Neg
80.0	45.0	75.0	45.0	75.0	45.0	75.0	45.0	75.0	45.0	75.0	45.0	75.0	45.0	75.0
84.0	45.0	75.0	45.0	75.0	45.0	75.0	45.0	75.0	45.0	75.0	45.0	75.0	45.0	75.0
96.0	45.0	75.0	45.0	75.0	45.0	75.0	45.0	75.0	45.0	75.0	45.0	72.5	45.0	68.2
102.0	45.0	75.0	45.0	75.0	45.0	75.0	45.0	75.0	45.0	72.1	45.0	66.7	45.0	62.5
108.0	45.0	75.0	45.0	75.0	45.0	75.0	45.0	73.9	45.0	67.0	45.0	61.7	45.0	57.7
114.0	45.0	75.0	45.0	75.0	45.0	75.0	45.0	69.1	45.0	62.5	45.0	57.5	45.0	53.6
120.0	45.0	75.0	45.0	75.0	45.0	73.5	45.0	64.9	45.0	58.6	45.0	53.8	45.0	50.0

**Maximum design pressure capacity chart**

**8100 Series Non-Reinforced Aluminum SGD Corner and Bypass with 2 1/4" Riser**

Height (in)	Nominal Single Panel Width (in)													
	24.0		30.0		36.0		42.0		48.0		54.0		60.0	
	Pos	Neg	Pos	Neg	Pos	Neg	Pos	Neg	Pos	Neg	Pos	Neg	Pos	Neg
80.0	60.0	75.0	60.0	75.0	60.0	75.0	60.0	75.0	60.0	75.0	60.0	75.0	60.0	75.0
84.0	60.0	75.0	60.0	75.0	60.0	75.0	60.0	75.0	60.0	75.0	60.0	75.0	60.0	75.0
96.0	60.0	75.0	60.0	75.0	60.0	75.0	60.0	75.0	60.0	75.0	60.0	72.5	60.0	68.2
102.0	60.0	75.0	60.0	75.0	60.0	75.0	60.0	75.0	60.0	72.1	60.0	66.7	60.0	62.5
108.0	60.0	75.0	60.0	75.0	60.0	75.0	60.0	73.9	60.0	67.0	60.0	61.7	57.7	57.7
114.0	60.0	75.0	60.0	75.0	60.0	75.0	60.0	69.1	60.0	62.5	57.5	57.5	53.6	53.6
120.0	60.0	75.0	60.0	75.0	60.0	73.5	60.0	64.9	58.6	58.6	53.8	53.8	50.0	50.0

**Maximum design pressure capacity chart**

**8100 Series Non-Reinforced Aluminum SGD Corner and Bypass with 3" Riser**

Height (in)	Nominal Single Panel Width (in)													
	24.0		30.0		36.0		42.0		48.0		54.0		60.0	
	Pos	Neg	Pos	Neg	Pos	Neg	Pos	Neg	Pos	Neg	Pos	Neg	Pos	Neg
80.0	75.0	75.0	75.0	75.0	75.0	75.0	75.0	75.0	75.0	75.0	75.0	75.0	75.0	75.0
84.0	75.0	75.0	75.0	75.0	75.0	75.0	75.0	75.0	75.0	75.0	75.0	75.0	75.0	75.0
96.0	75.0	75.0	75.0	75.0	75.0	75.0	75.0	75.0	75.0	75.0	72.5	72.5	68.2	68.2
102.0	75.0	75.0	75.0	75.0	75.0	75.0	75.0	72.1	72.1	66.7	66.7	62.5	62.5	62.5
108.0	75.0	75.0	75.0	75.0	75.0	75.0	73.9	73.9	67.0	67.0	61.7	61.7	57.7	57.7
114.0	75.0	75.0	75.0	75.0	75.0	75.0	69.1	69.1	62.5	62.5	57.5	57.5	53.6	53.6
120.0	75.0	75.0	75.0	75.0	73.5	73.5	64.9	64.9	58.6	58.6	53.8	53.8	50.0	50.0

REVISIONS

REV	DESCRIPTION	DATE	APPROVED
A	REVISED NOTES	10/31/11	R.L.
B	ADDED 5T	02/14/17	R.L.
C	REVISED PER NEW REQUIREMENTS	02/01/18	R.L.

SIGNED: 02/01/2018

**WinDoor**  
INCORPORATED

7500 AMSTERDAM DRIVE  
ORLANDO, FL 32832  
Phone: 407.481.8400  
Fax: 407.481.0505 www.windoorinc.com

8100 SERIES NON-REINFORCED ALUMINUM SGD  
CORNER AND BYPASS (5'0x10'0 PANELS) - LMI  
DESIGN PRESSURE CHARTS

DRAWN: TJH	DWG. NO. 08-01168	REV C
SCALE NTS	DATE 02/15/11	SHEET 6 OF 14

L. ROBERTO LOMAS P.E.  
1432 WOODFORD RD LEWISVILLE, NC 27023  
434-688-0609 rllomas@rlomaspe.com



Luis R. Lomas P.E.  
FL No.: 62514

REVISIONS			
REV	DESCRIPTION	DATE	APPROVED
A	REVISED NOTES	10/31/11	R.L.
B	ADDED 5T	02/14/17	R.L.
C	REVISED PER NEW REQUIREMENTS	02/01/18	R.L.

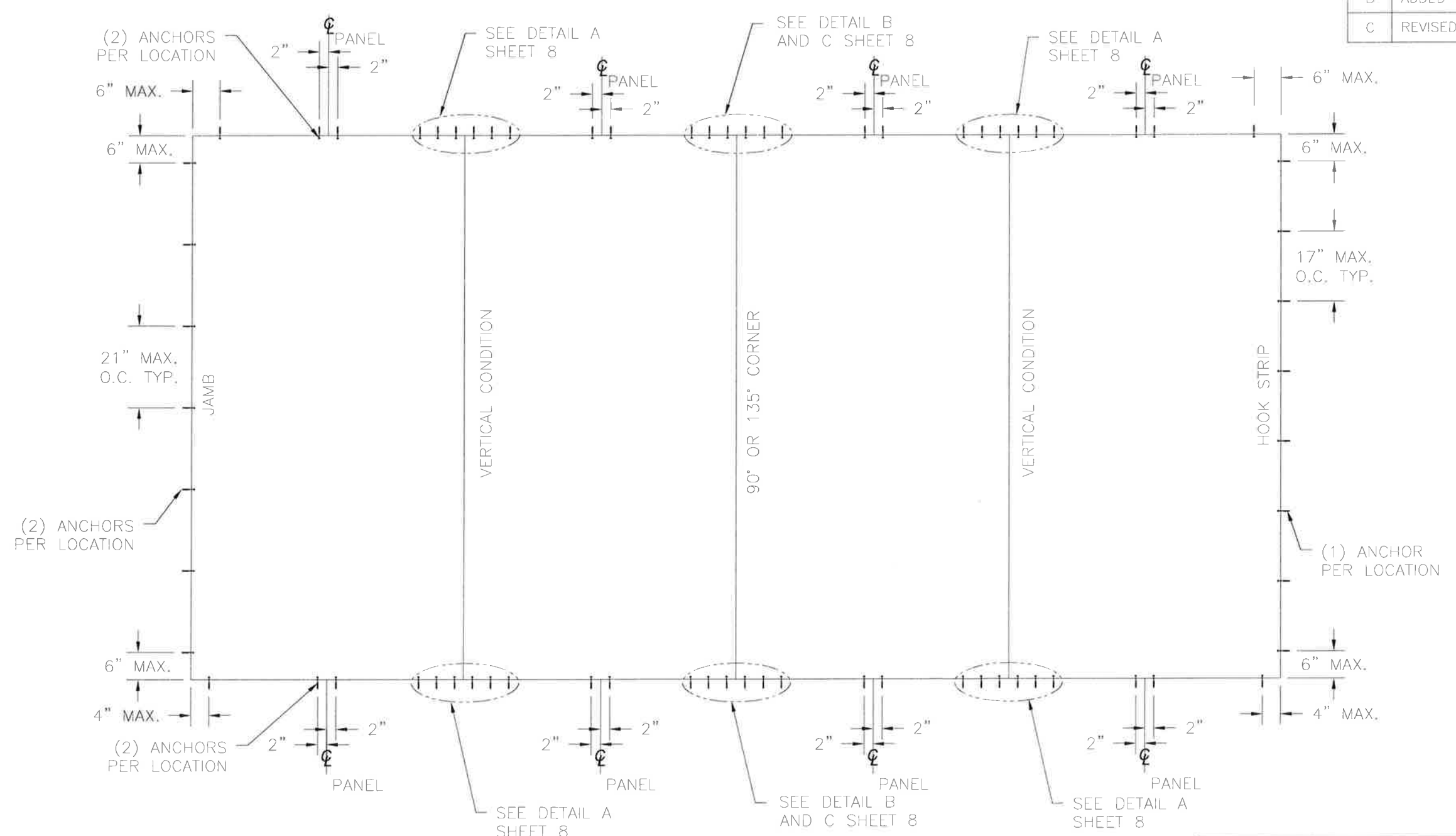

**5'0x10'0 PANELS ANCHOR LAYOUT**  
 4PANEL UNIT SHOWN, APPLICABLE TO ALL CONFIGURATIONS. SEE SHEET 8 FOR DETAILS

SIGNED: 02/01/2018

<b>WinDoor</b> INCORPORATED		7500 AMSTERDAM DRIVE ORLANDO, FL 32832 Phone: 407.481.8400 Fax: 407.481.0505 www.windoorinc.com
8100 SERIES NON-REINFORCED ALUMINUM SGD CORNER AND BYPASS (5'0x10'0 PANELS) - LMI ANCHORING LAYOUT		
DRAWN: TJH	DWG NO. 08-01168	REV C
SCALE NTS	DATE 02/15/11	SHEET 7 OF 14
L. ROBERTO LOMAS P.E. 1432 WOODFORD RD LEWISVILLE, NC 27023 434-688-0609 rllomas@rlomaspe.com		

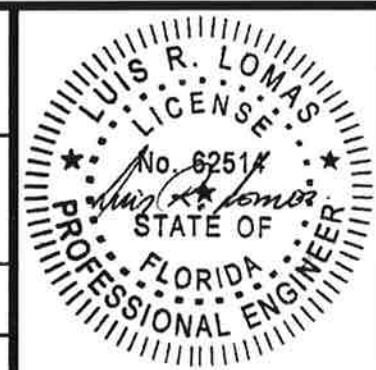

Luis R. Lomas P.E.  
FL No.: 62514

POCKET



**HOOKSTRIP ANCHOR LOCATION**

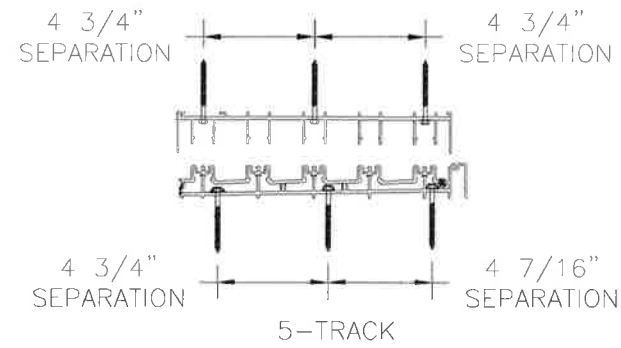
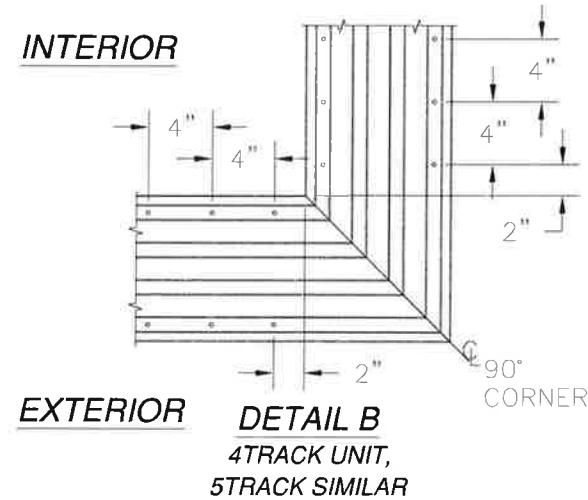
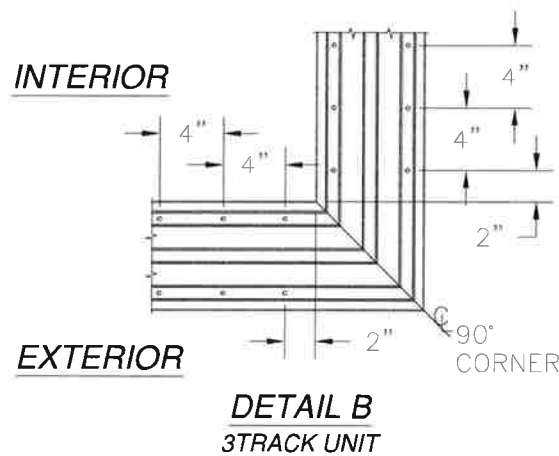
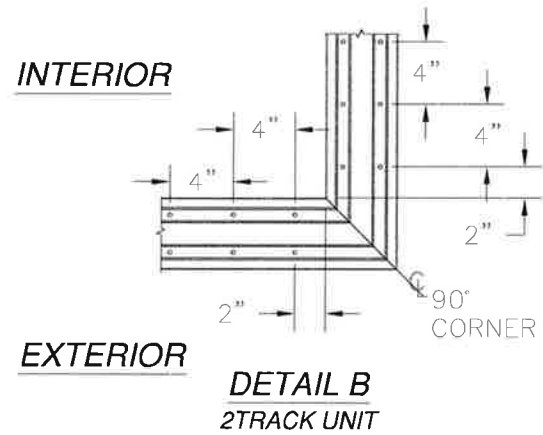
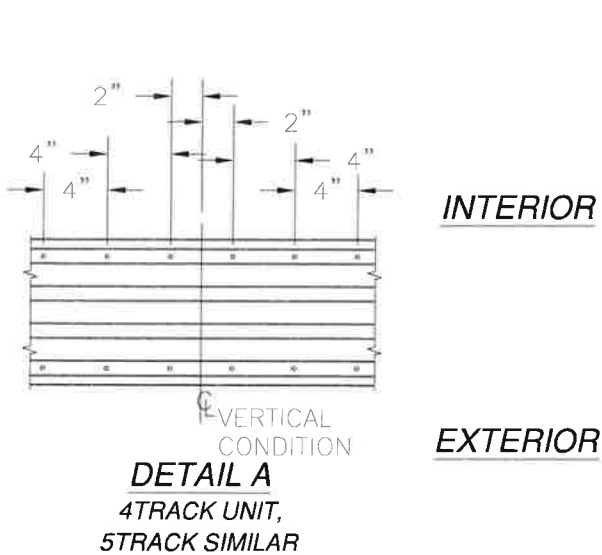
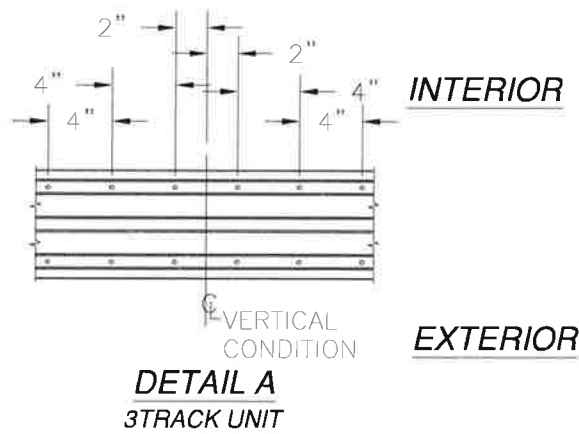
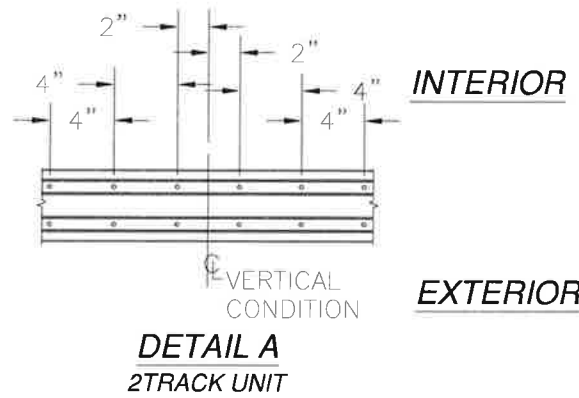

**HEAD & SILL ANCHOR LOCATIONS**

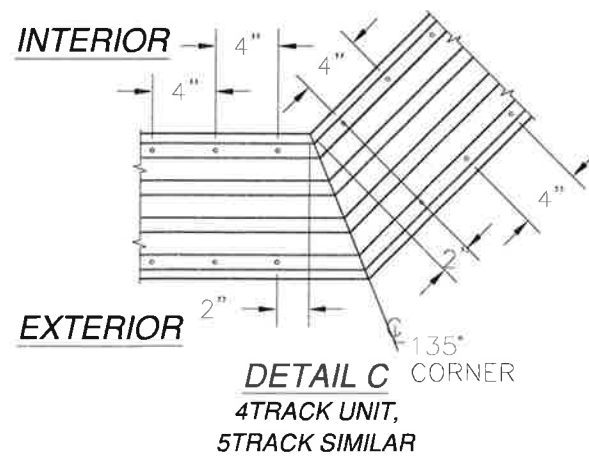
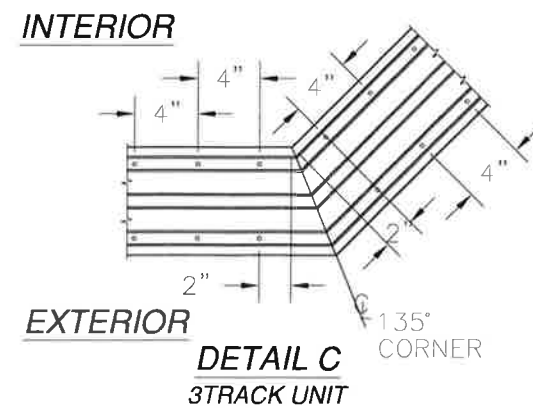
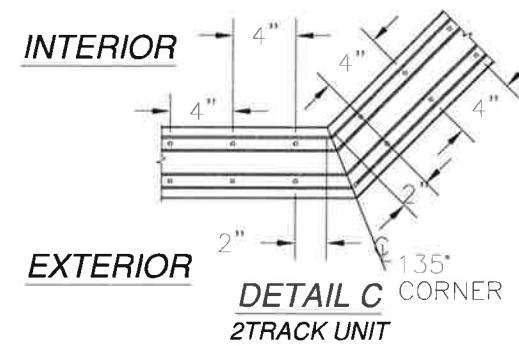

REVISIONS			
REV	DESCRIPTION	DATE	APPROVED
A	REVISED NOTES	10/31/11	R.L.
B	ADDED 5T	02/14/17	R.L.
C	REVISED PER NEW REQUIREMENTS	02/01/18	R.L.

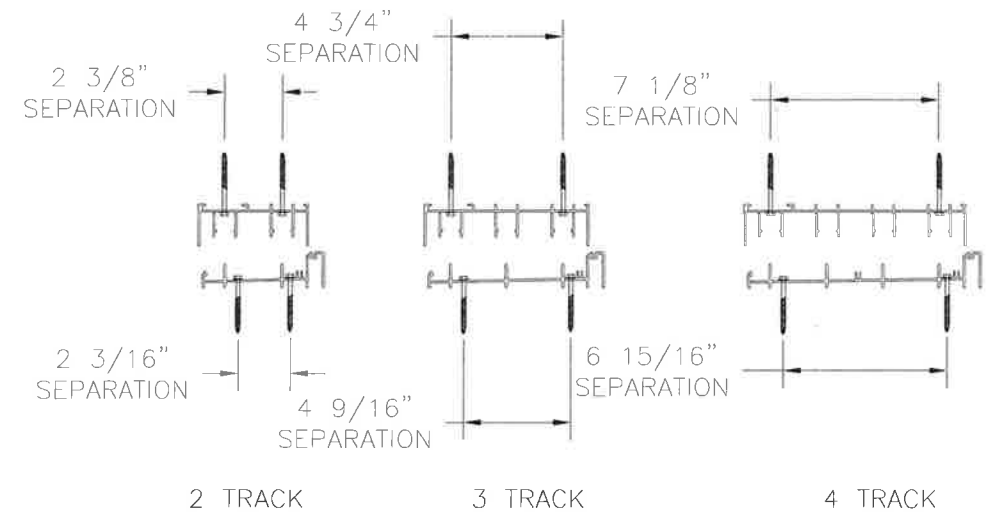

**HEAD & SILL ANCHOR LOCATIONS**

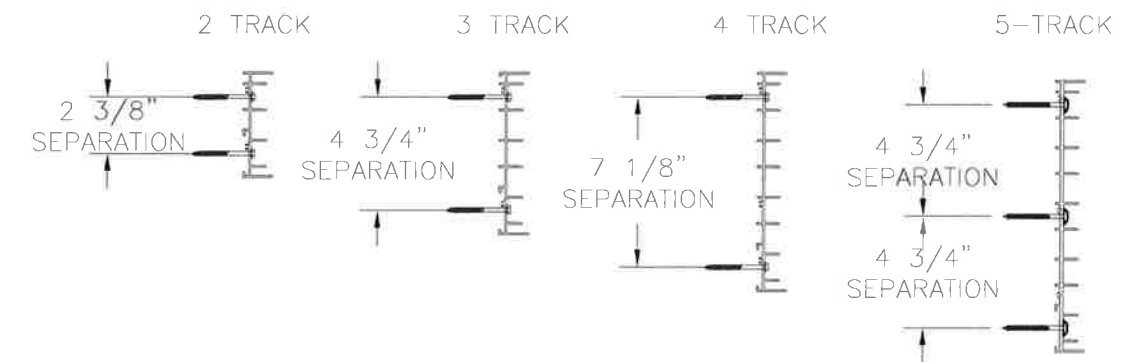

**JAMB ANCHOR LOCATIONS**

SIGNED: 02/01/2018

**WinDoor**  
INCORPORATED

7500 AMSTERDAM DRIVE  
ORLANDO, FL 32832  
Phone: 407.481.8400  
Fax: 407.481.0505      www.windoorinc.com

8100 SERIES NON-REINFORCED ALUMINUM SGD  
CORNER AND BYPASS (5'0x10'0 PANELS) - LMI  
CLUSTER AND ANCHOR LOCATION DETAILS

DRAWN: TJH	DWG NO. 08-01168	REV C
SCALE NTS	DATE 02/15/11	SHEET 8 OF 14

L. ROBERTO LOMAS P.E.  
1432 WOODFORD RD LEWISVILLE, NC 27023  
434-688-0609      rllomas@lrlomaspe.com

LUIS R. LOMAS  
LICENSE  
No. 62514  
STATE OF  
FLORIDA  
PROFESSIONAL ENGINEER

Luis R. Lomas P.E.  
FL No.: 62514

REVISIONS			
REV	DESCRIPTION	DATE	APPROVED
A	REVISED NOTES	10/31/11	R.L.
B	ADDED 5T	02/14/17	R.L.
C	REVISED PER NEW REQUIREMENTS	02/01/18	R.L.

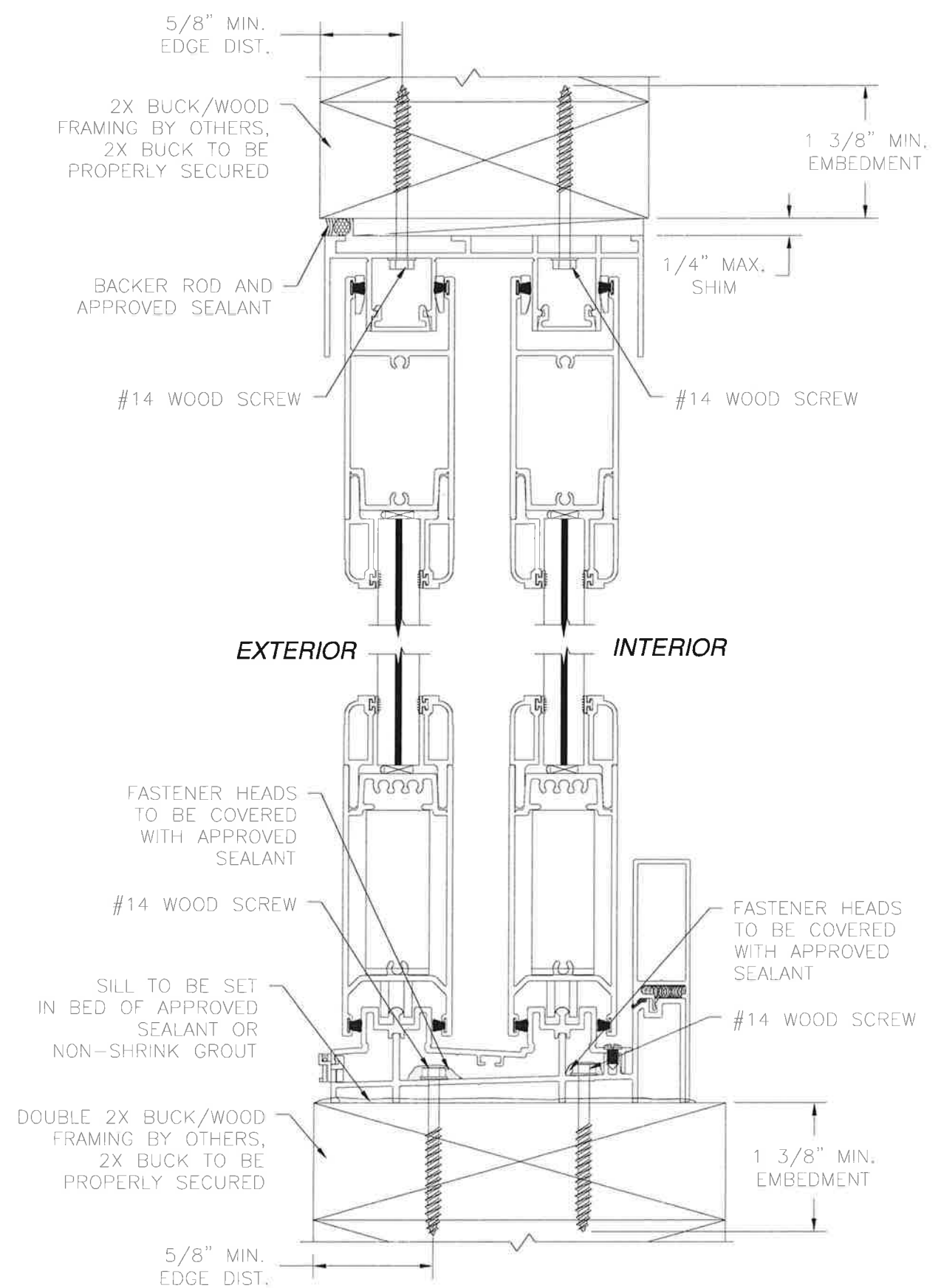

**VERTICAL CROSS SECTION**  
 2X BUCK/WOOD FRAMING INSTALLATION  
 2 TRACK FRAME SHOWN, 3 TRACK,  
 4 TRACK AND 5 TRACK SIMILAR

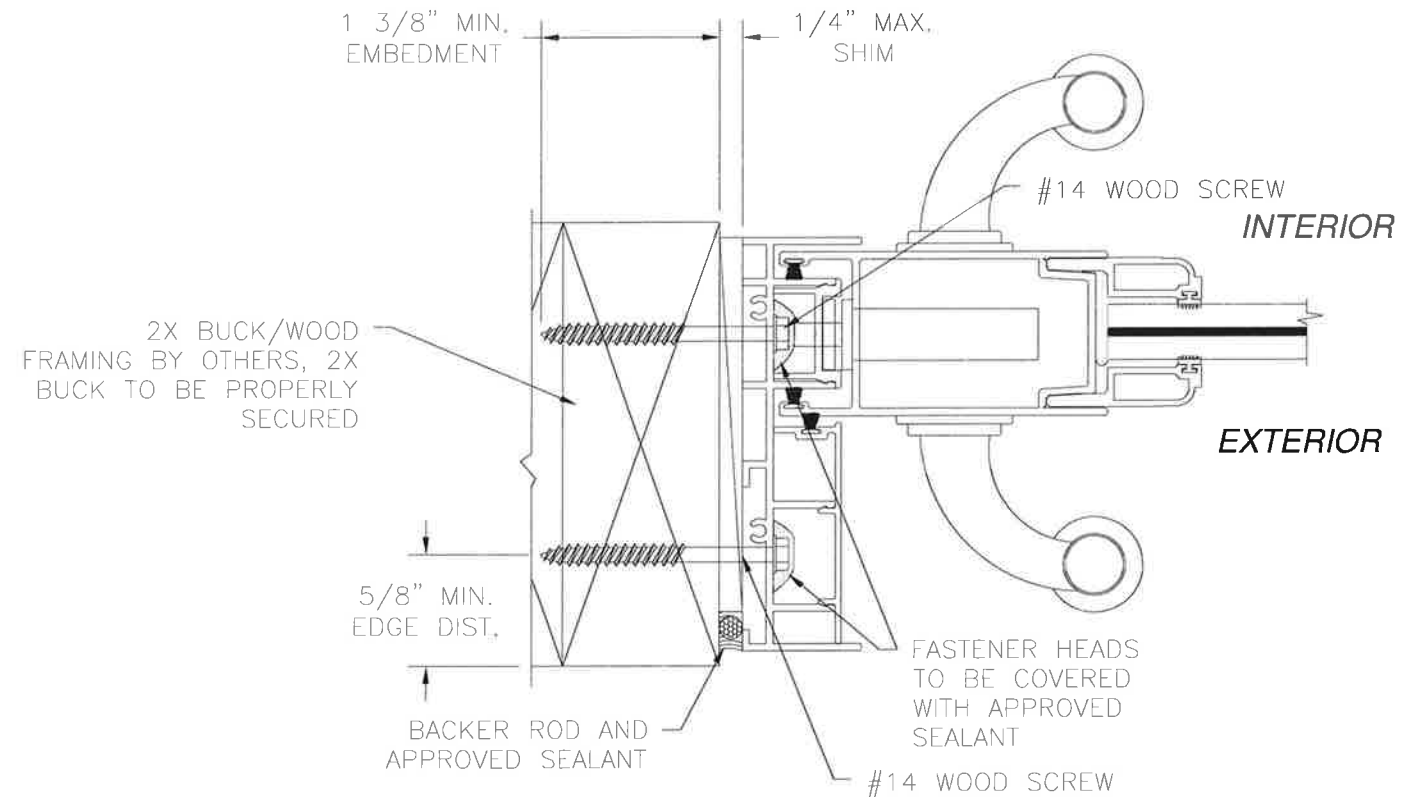

**HORIZONTAL CROSS SECTION**  
 2X BUCK/WOOD FRAMING INSTALLATION  
 2 TRACK FRAME SHOWN, 3 TRACK,  
 4 TRACK AND 5 TRACK SIMILAR

- NOTES:**
1. INTERIOR AND EXTERIOR FINISHES, BY OTHERS, NOT SHOWN FOR CLARITY.
  2. PERIMETER AND JOINT SEALANT BY OTHERS TO BE DESIGNED IN ACCORDANCE WITH ASTM E2112

**WinDoor**  
 INCORPORATED

7500 AMSTERDAM DRIVE  
 ORLANDO, FL 32832  
 Phone: 407.481.8400  
 Fax: 407.481.0505  
 www.windoorinc.com

8100 SERIES NON-REINFORCED ALUMINUM SGD  
 CORNER AND BYPASS (5'0x10'0 PANELS) - LMI  
 INSTALLATION DETAILS

DRAWN: TJH	DWG. NO. 08-01168	REV C
SCALE NTS	DATE 02/15/11	SHEET 9 OF 14

L. ROBERTO LOMAS P.E.  
 1432 WOODFORD RD LEWISVILLE, NC 27023  
 434-688-0609 rllomas@rlomaspe.com

SIGNED: 02/01/2018



Luis R. Lomas P.E.  
 FL No.: 62514



REVISIONS			
REV	DESCRIPTION	DATE	APPROVED
A	REVISED NOTES	10/31/11	R.L.
B	ADDED 5T	02/14/17	R.L.
C	REVISED PER NEW REQUIREMENTS	02/01/18	R.L.

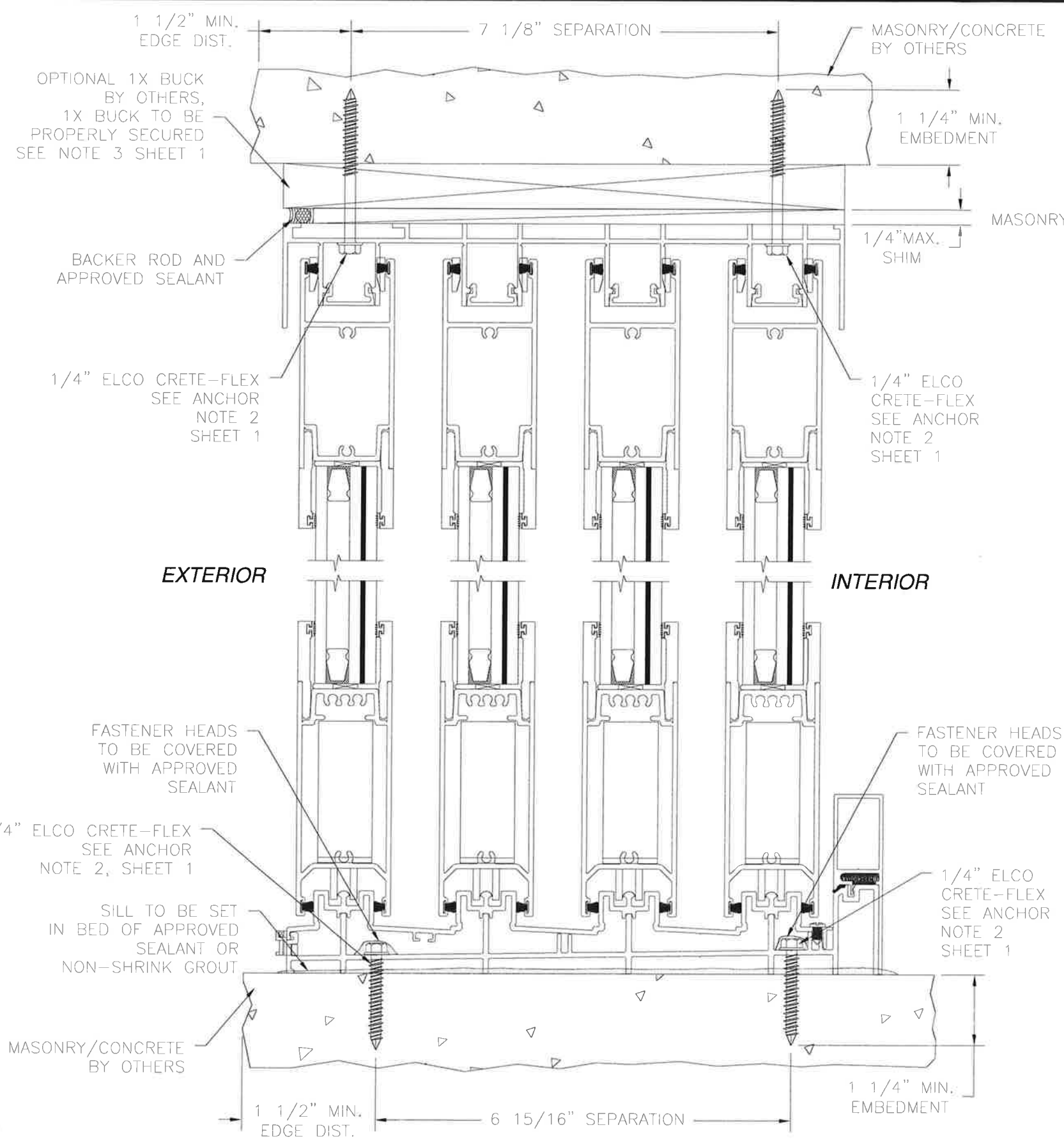

**VERTICAL CROSS SECTION**  
**MASONRY/CONCRETE INSTALLATION**  
**4 TRACK FRAME SHOWN, 2 TRACK,**  
**3 TRACK AND 5 TRACK SIMILAR**

- NOTES:**
1. INTERIOR AND EXTERIOR FINISHES, BY OTHERS, NOT SHOWN FOR CLARITY.
  2. PERIMETER AND JOINT SEALANT BY OTHERS TO BE DESIGNED IN ACCORDANCE WITH ASTM E2112

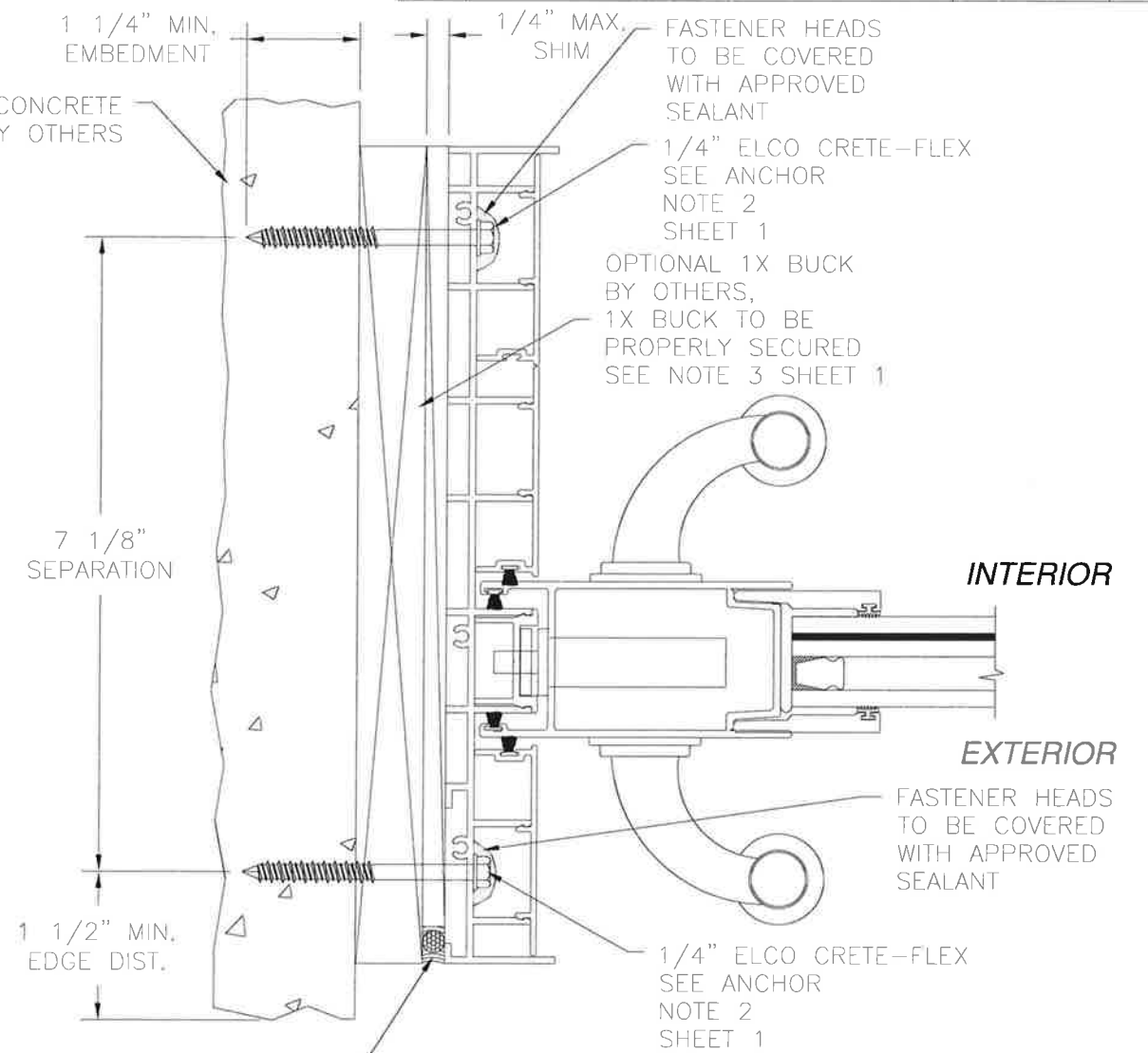

**HORIZONTAL CROSS SECTION**  
**MASONRY/CONCRETE INSTALLATION**  
**4 TRACK FRAME SHOWN, 2 TRACK,**  
**3 TRACK AND 5 TRACK SIMILAR**

SIGNED: 02/01/2018

<b>WinDoor</b> INCORPORATED		7500 AMSTERDAM DRIVE ORLANDO, FL 32832 Phone: 407.481.8400 Fax: 407.481.0505 www.windoorinc.com	
8100 SERIES NON-REINFORCED ALUMINUM SGD CORNER AND BYPASS (5'0x10'0 PANELS) - LMI INSTALLATION DETAILS			
DRAWN: TJH	DWG. NO. 08-01168	REV C	
SCALE NTS	DATE 02/15/11	SHEET 10 OF 14	
L. ROBERTO LOMAS P.E. 1432 WOODFORD RD LEWISVILLE, NC 27023 434-688-0609 rllomas@lrlomaspe.com			

Professional Engineer Seal for Luis R. Lomas, State of Florida, License No. 62514.

Luis R. Lomas P.E.  
FL No.: 62514

REVISIONS			
REV	DESCRIPTION	DATE	APPROVED
A	REVISED NOTES	10/31/11	R.L.
B	ADDED 5T	02/14/17	R.L.
C	REVISED PER NEW REQUIREMENTS	02/01/18	R.L.

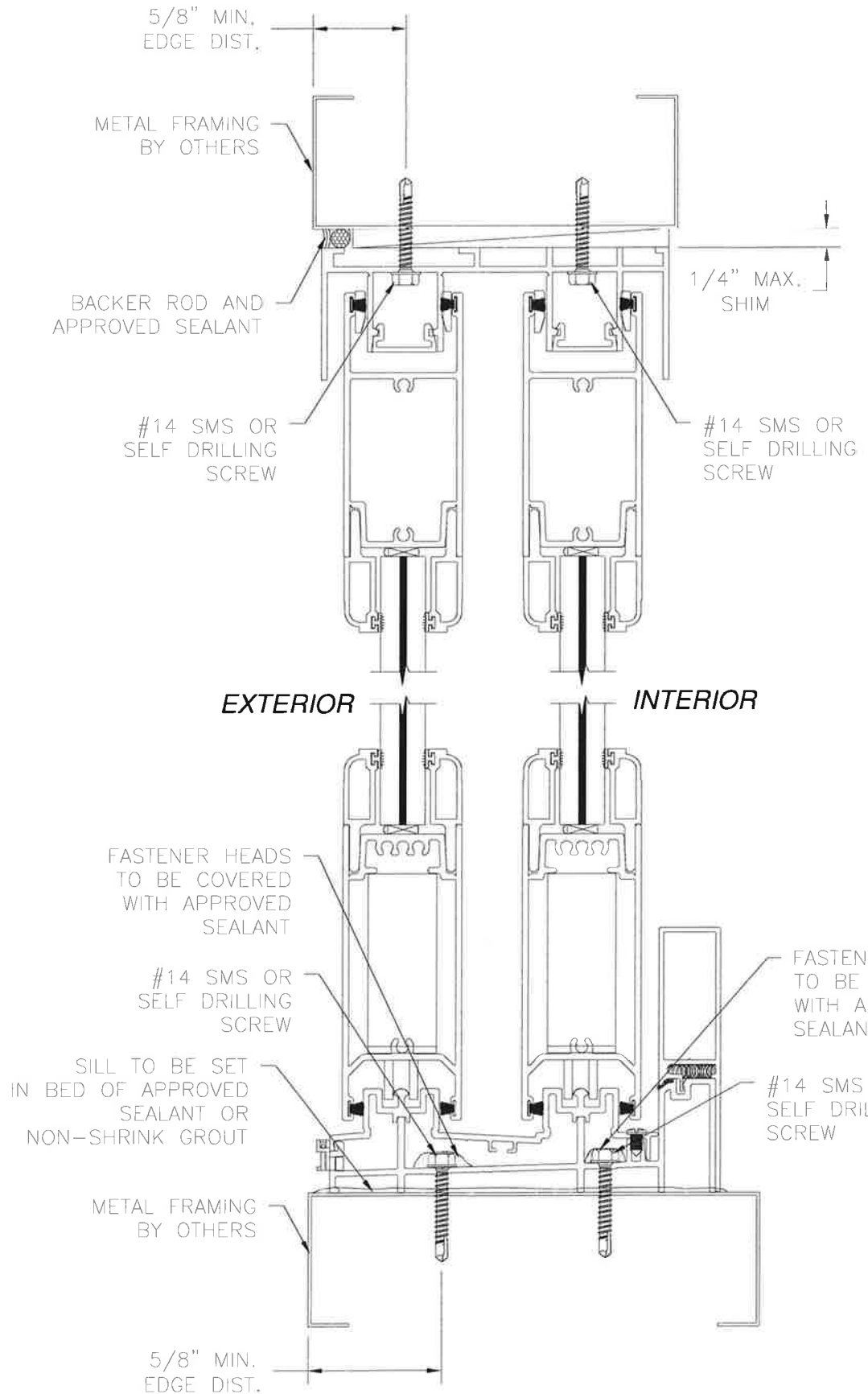

**VERTICAL CROSS SECTION**  
 METAL FRAMING INSTALLATION  
 2 TRACK FRAME SHOWN, 3 TRACK,  
 4 TRACK AND 5 TRACK SIMILAR

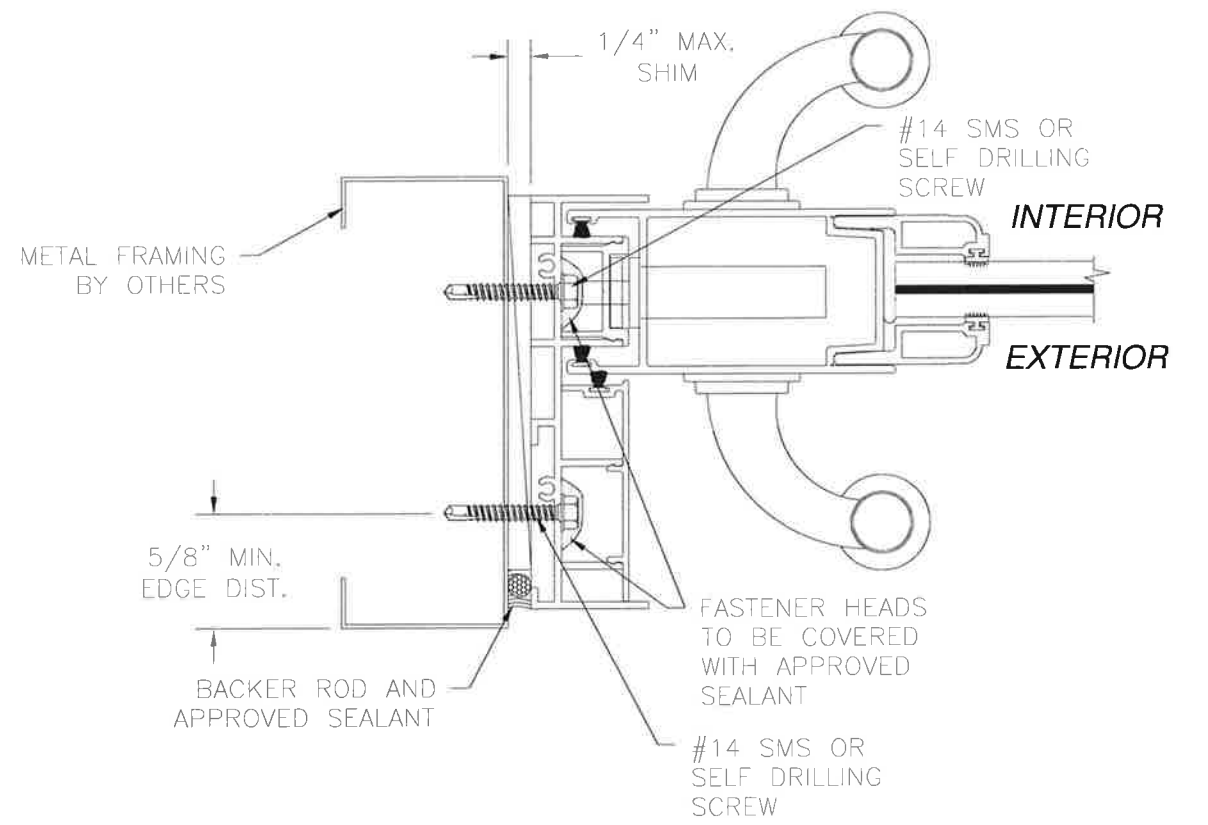

**HORIZONTAL CROSS SECTION**  
 METAL FRAMING INSTALLATION  
 2 TRACK FRAME SHOWN, 3 TRACK,  
 4 TRACK AND 5 TRACK SIMILAR

- NOTES:**
1. INTERIOR AND EXTERIOR FINISHES, BY OTHERS, NOT SHOWN FOR CLARITY.
  2. PERIMETER AND JOINT SEALANT BY OTHERS TO BE DESIGNED IN ACCORDANCE WITH ASTM E2112

SIGNED: 02/01/2018

**WinDoor** 7500 AMSTERDAM DRIVE  
 INCORPORATED ORLANDO, FL 32832  
 Phone: 407.481.8400  
 Fax: 407.481.0505 www.windoorinc.com

8100 SERIES NON-REINFORCED ALUMINUM SGD  
 CORNER AND BYPASS (5'0x10'0 PANELS) - LMI  
 INSTALLATION DETAILS

DRAWN: TJH	DWG NO. 08-01168	REV C
SCALE NTS	DATE 02/15/11	SHEET 11 OF 14

L. ROBERTO LOMAS P.E.  
 1432 WOODFORD RD LEWISVILLE, NC 27023  
 434-688-0609 rllomas@lrlomaspe.com



Luis R. Lomas P.E.  
 FL No.: 62514

REVISIONS			
REV	DESCRIPTION	DATE	APPROVED
A	REVISED NOTES	10/31/11	R.L.
B	ADDED 5T	02/14/17	R.L.
C	REVISED PER NEW REQUIREMENTS	02/01/18	R.L.

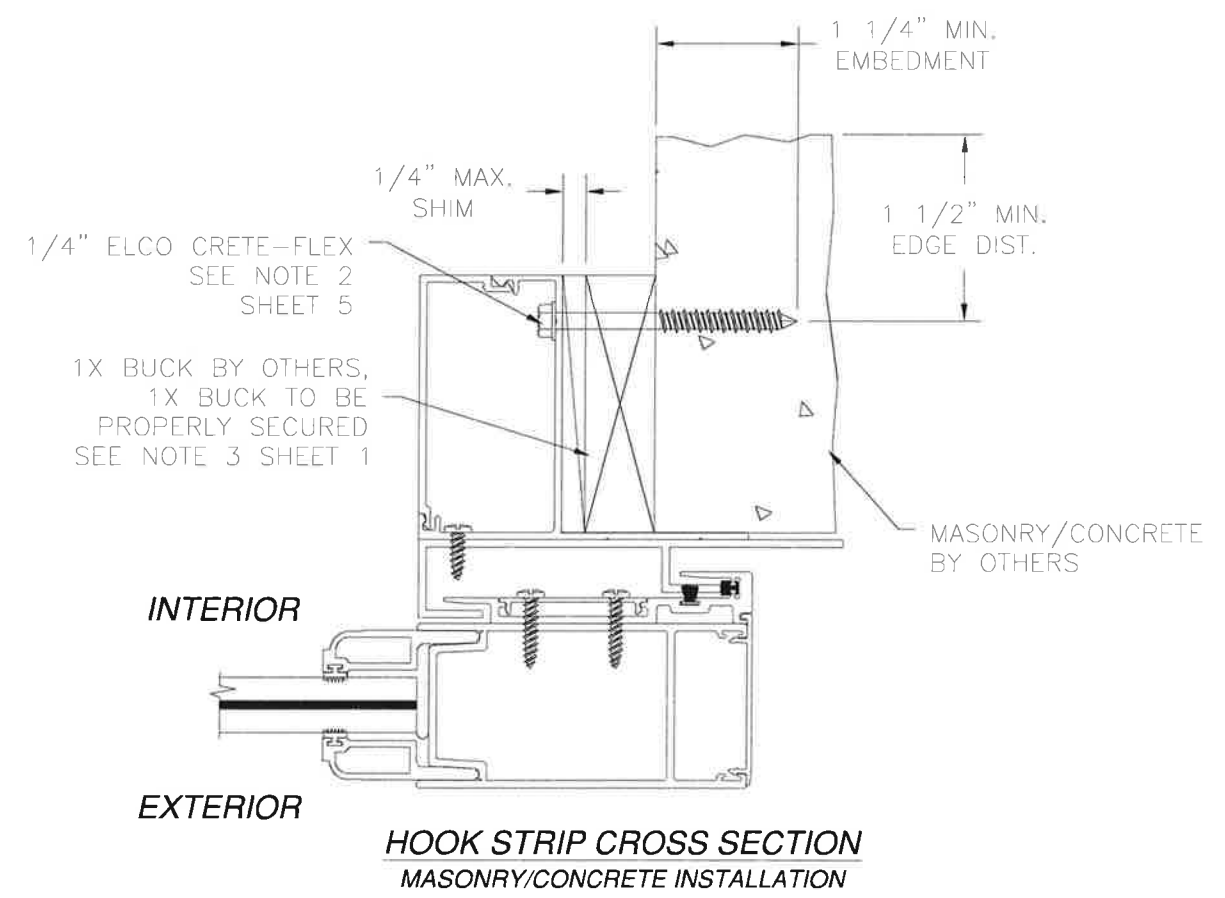
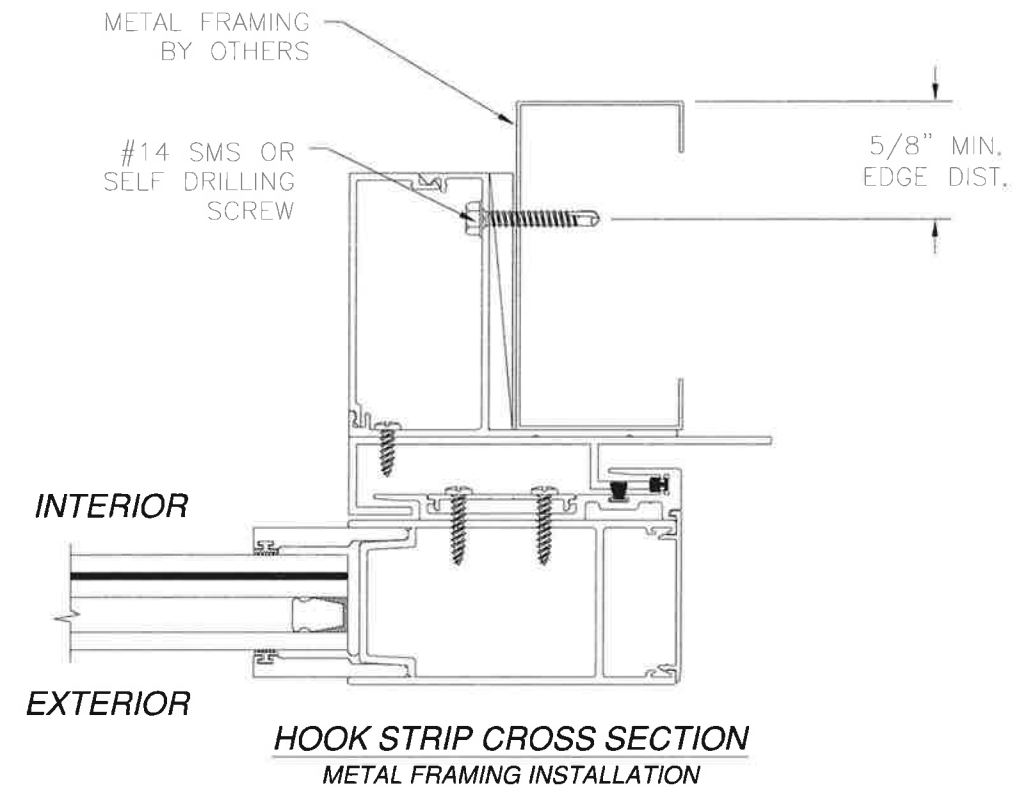
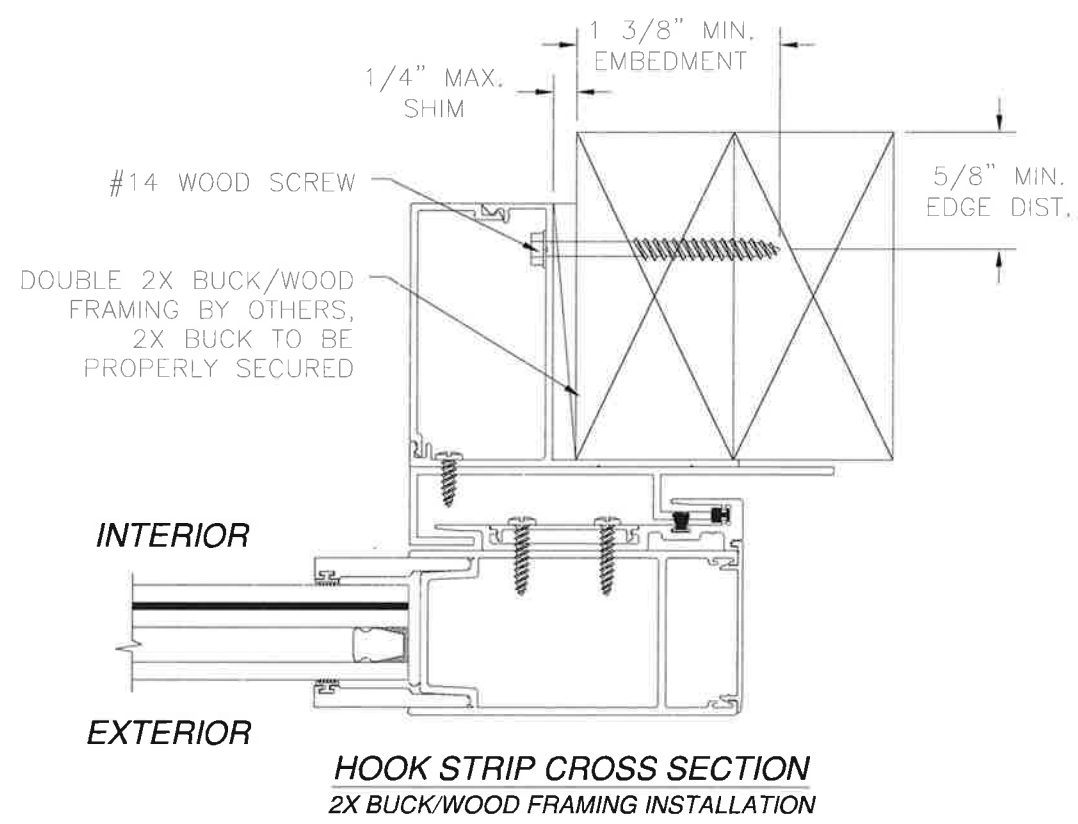

SIGNED: 02/01/2018

**WinDoor**  
INCORPORATED

7500 AMSTERDAM DRIVE  
ORLANDO, FL 32832  
Phone: 407.481.8400  
Fax: 407.481.0505  
www.windoorinc.com

8100 SERIES NON-REINFORCED ALUMINUM SGD CORNER AND BYPASS (5'0x10'0 PANELS) - LMI INSTALLATION DETAILS

DRAWN: TJH	DWG NO. 08-01168	REV C
SCALE NTS	DATE 02/15/11	SHEET 12 OF 14

L. ROBERTO LOMAS P.E.  
1432 WOODFORD RD LEWISVILLE, NC 27023  
434-688-0609 rllomas@rlomaspe.com

Luis R. Lomas P.E.  
FL No.: 62514

REVISIONS			
REV	DESCRIPTION	DATE	APPROVED
A	REVISED NOTES	10/31/11	R.L.
B	ADDED 5T	02/14/17	R.L.
C	REVISED PER NEW REQUIREMENTS	02/01/18	R.L.

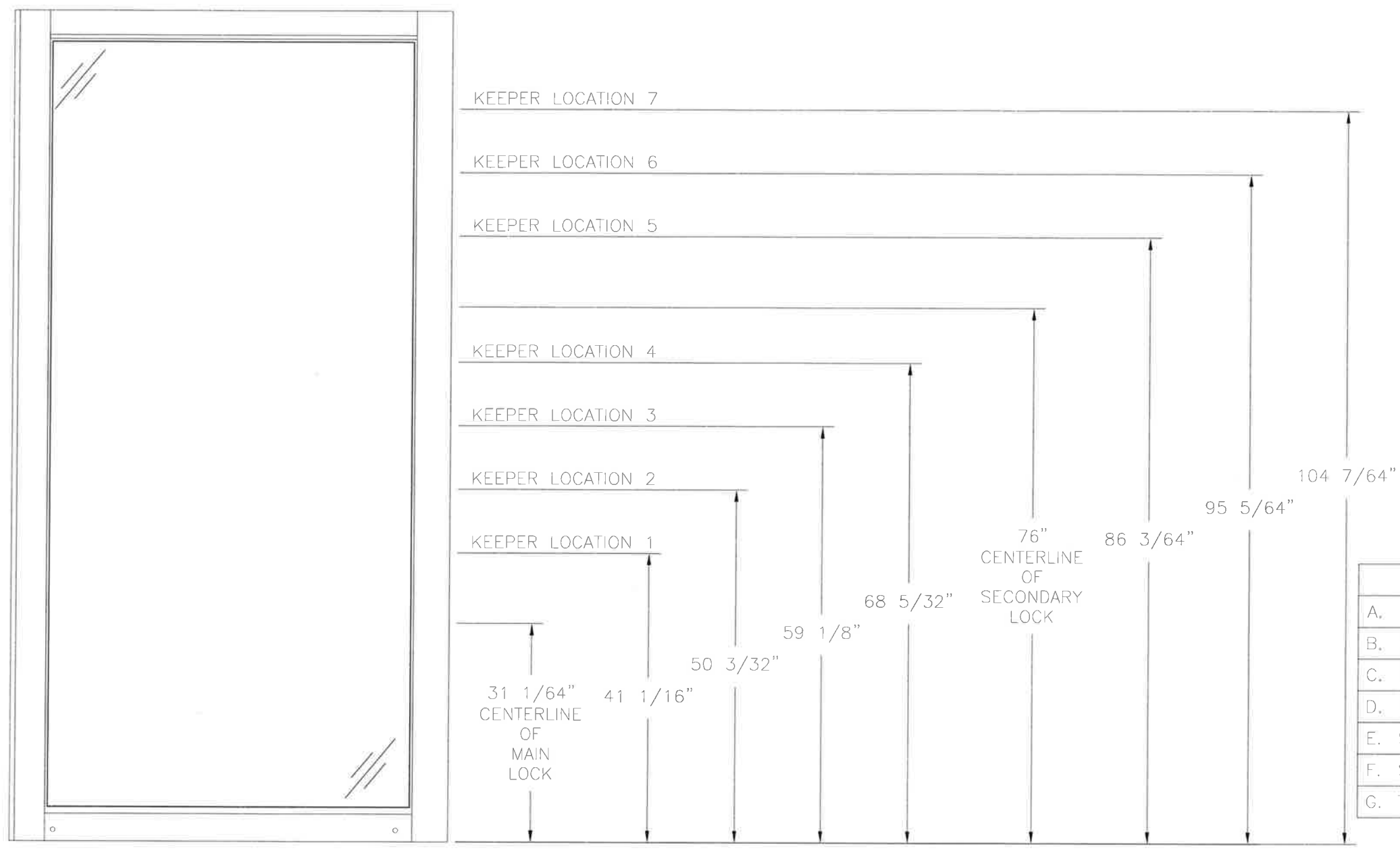

<b>HARDWARE SCHEDULE</b>	
A.	LOCKING LINKAGE (CORNER) #896624 BY SIEGENIA
B.	LOCK OPERATING GEAR (CORNER) # 715449 BY SIEGENIA
C.	KEEPERS (CORNER) 81H-01 BY SELJAN
D.	DUAL POINT MORTISE LOCK & KEEPER #2468
E.	SIGNATURE DUMMY HANDLE SET
F.	SIGNATURE HANDLE SET #7500 A04
G.	TANDEM ROLLER #1988-9000

**CORNER LOCKING HARDWARE LOCATIONS**

SIGNED: 02/01/2018

**WinDoor** INCORPORATED  
 7500 AMSTERDAM DRIVE  
 ORLANDO, FL 32832  
 Phone: 407.481.8400  
 Fax: 407.481.0505  
 www.windoorinc.com

8100 SERIES NON-REINFORCED ALUMINUM SGD  
 CORNER AND BYPASS (5'0x10'0 PANELS) - LMI  
 LOCKING HARDWARE LAYOUT

DRAWN: TJH	DWG. NO. 08-01168	REV C
SCALE NTS	DATE 02/15/11	SHEET 13 OF 14

L. ROBERTO LOMAS P.E.  
 1432 WOODFORD RD LEWISVILLE, NC 27023  
 434-688-0609 rllomas@lrlomaspe.com

Luis R. Lomas P.E.  
 FL No.: 62514

REVISIONS

REV	DESCRIPTION	DATE	APPROVED
A	REVISED NOTES	10/31/11	R.L.
B	ADDED 5T	02/14/17	R.L.
C	REVISED PER NEW REQUIREMENTS	02/01/18	R.L.

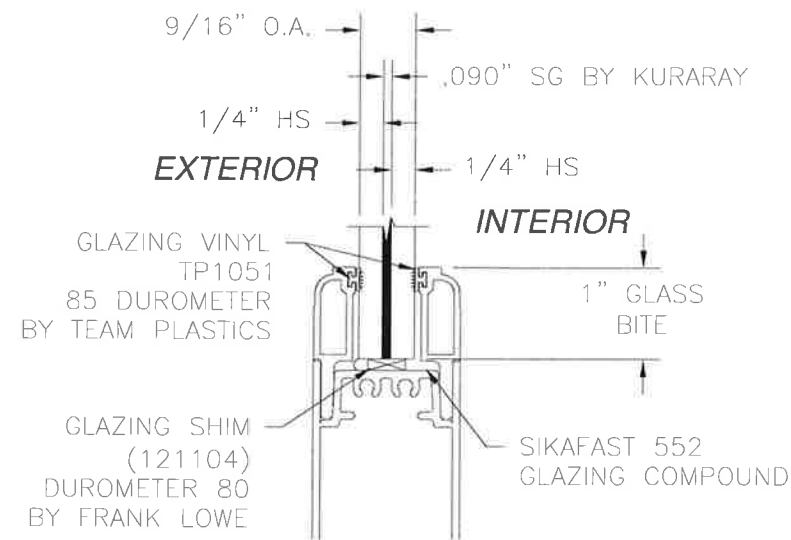

**GLAZING OPTION A**

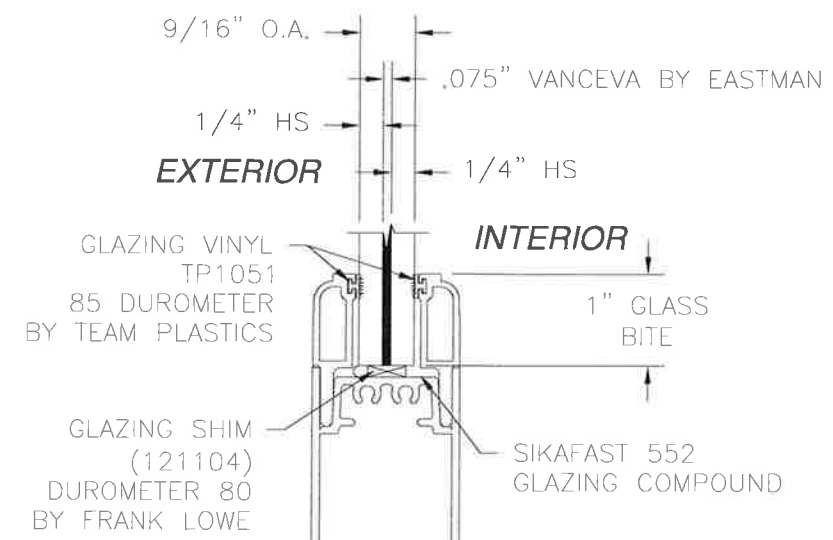

**GLAZING OPTION B**

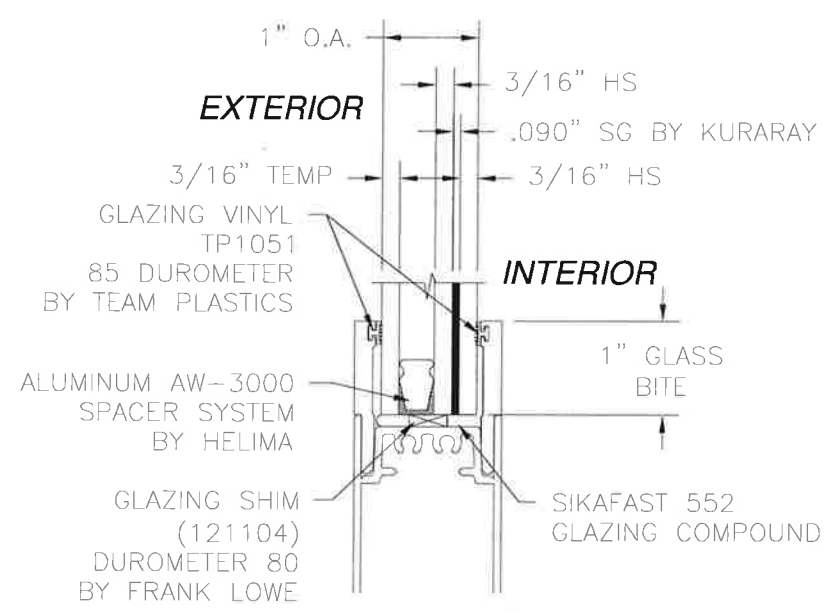

**GLAZING OPTION C**

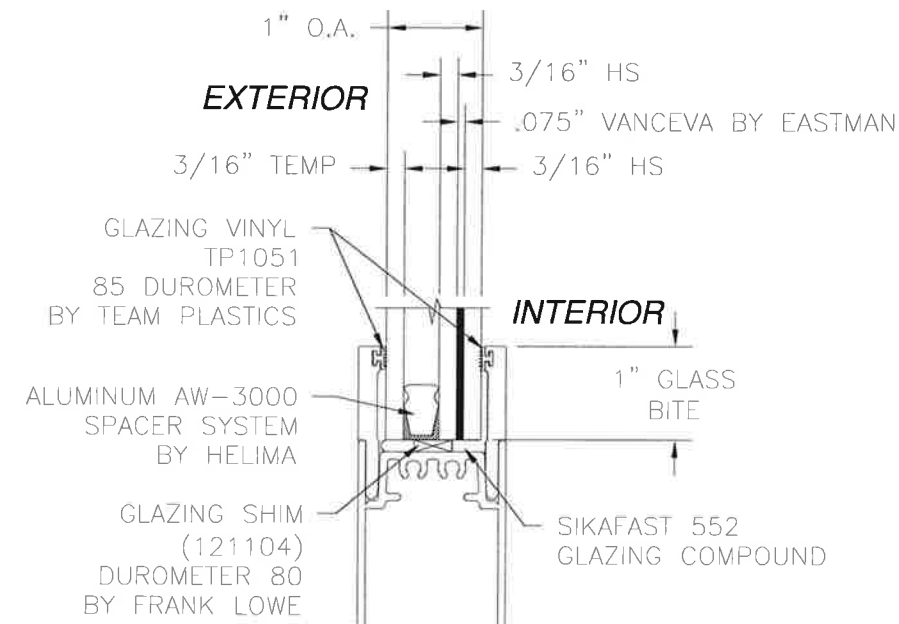

**GLAZING OPTION D**

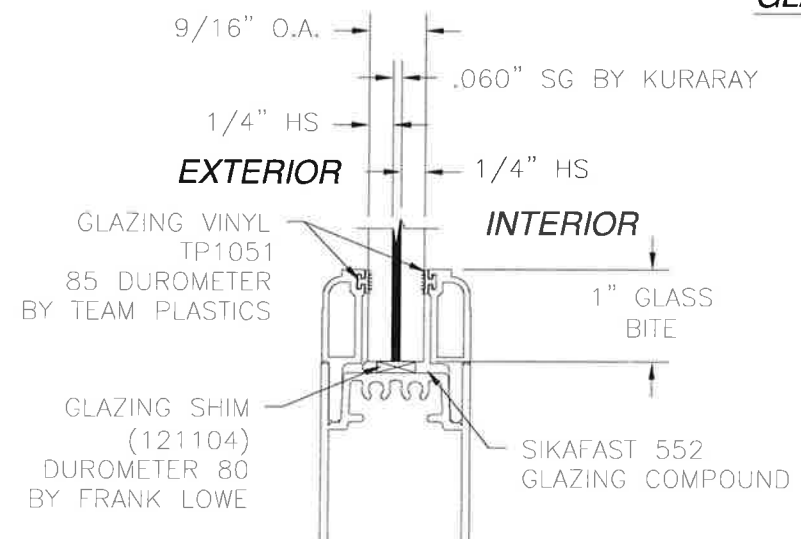

**GLAZING OPTION E**

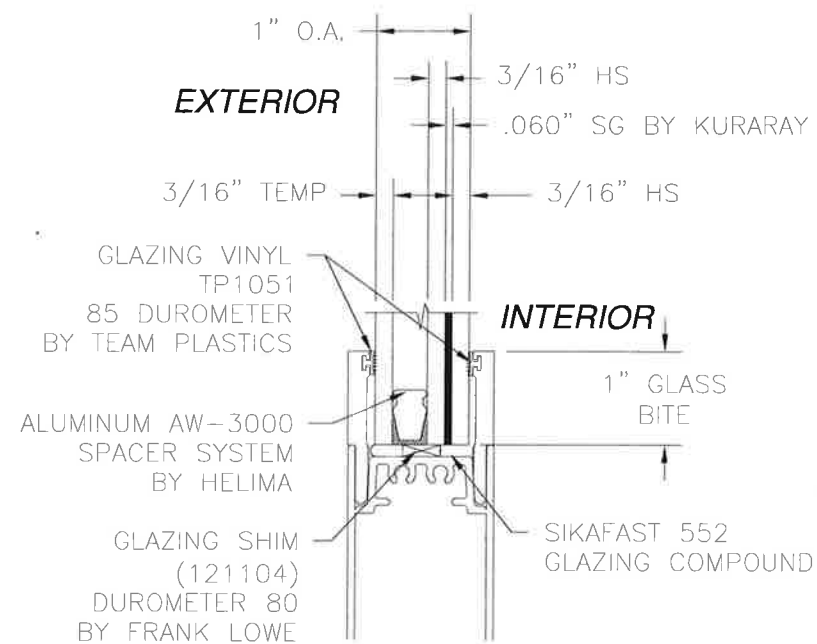

**GLAZING OPTION F**

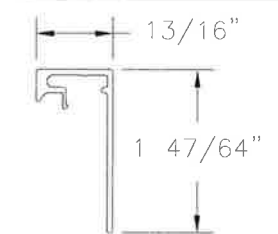

**1 3/4" SILL RISER**  
ALUMINUM 6063-T6 .060" THICK

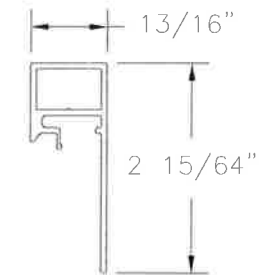

**2 1/4" SILL RISER**  
ALUMINUM 6063-T6 .060" THICK

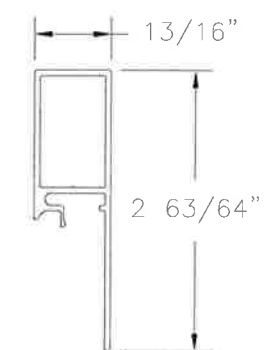

**3" SILL RISER**  
ALUMINUM 6063-T6 .060" THICK

SIGNED: 02/01/2018

**WinDoor INCORPORATED**  
7500 AMSTERDAM DRIVE  
ORLANDO, FL 32832  
Phone: 407.481.8400  
Fax: 407.481.0505  
www.windoorinc.com

8100 SERIES NON-REINFORCED ALUMINUM SGD CORNER AND BYPASS (5'0x10'0 PANELS) - LMI COMPONENTS & GLAZING DETAILS

DRAWN: TJH	DWG NO. 08-01168	REV C
SCALE NTS	DATE 02/15/11	SHEET 14 OF 14

L. ROBERTO LOMAS P.E.  
1432 WOODFORD RD LEWISVILLE, NC 27023  
434-688-0609 rllomas@lrlomaspe.com

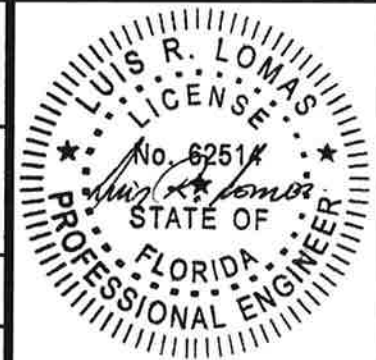

Luis R. Lomas P.E.  
FL No.: 62514