



City of Belle Isle Job Site Card Window/Door PERMIT 2018- 04 - 040

PERMIT MUST BE POSTED ON SITE - A permit expires in 6 months if approved inspections are not recorded /scheduled within that time frame. **You are responsible for scheduling and keeping track of all your inspections -**

Permit Number: 2018- 04-040
Site Address: 5332 Hawford Cir. 32812
Class: Residential
Description of Work: Replace (1) door size for size

Issue Date: 4/16/2018
Parcel# 20-23-30-9375-00-560
Subdivision:

Issued To: D & D GARAGE DOORS INC
Name: MILLER, DALLAS LEE

Business Phone: 941 371-7242
Contractor License # CBC1258205

Payment Date & Method: 4 / 20 / 2018

Visa Master Card Amex Discover Check / Money Order # 9434

**Schedule Inspections via Email at: BDscheduling@universalengineering.com
SCHEDULE INSPECTIONS BY 4PM CUT OFF TIME
Inspection Results Will Be Sent Out the Following Business Day**

"WARNING TO OWNER: YOUR FAILURE TO RECORD A NOTICE OF COMMENCEMENT MAY RESULT IN YOUR PAYING TWICE FOR IMPROVEMENTS TO YOUR PROPERTY. IF YOU INTEND TO OBTAIN FINANCING, CONSULT WITH YOUR LENDER OR AN ATTORNEY BEFORE RECORDING YOUR NOTICE OF COMMENCEMENT."

Window/Door	INSPECTOR	DATE	COMMENTS
900 In-Progress			
910 Final			

Inspection requests are to be emailed to BDscheduling@UniversalEngineering.com; a confirmation email will be sent back to you upon scheduling. Next-Day Inspection requests must be made by 4pm. Please include the following in your request: Permit #, project address, type of inspection, date of the requested inspection, a contact name & a contact phone number. AM or PM may be requested but cannot be guaranteed.



City of Belle Isle
 Universal Engineering Sciences 3532 Maggie Blvd., Orlando, FL 32811
 Tel 407-581-8161 * Fax 407-581-0313 * www.universeengineering.com

RECEIVED
 APR 16 2018

**APPLICATION FOR SIZE-FOR-SIZE
 WINDOW / DOOR PERMIT**

WARNING TO OWNER: YOUR FAILURE TO RECORD A NOTICE OF COMMENCEMENT MAY RESULT IN YOUR PAYING TWICE FOR IMPROVEMENTS TO YOUR PROPERTY. A NOTICE OF COMMENCEMENT MUST BE RECORDED AND POSTED ON THE JOB SITE BEFORE THE FIRST INSPECTION. IF YOU INTEND TO OBTAIN FINANCING, CONSULT WITH YOUR LENDER OR AN ATTORNEY BEFORE RECORDING YOUR NOTICE OF COMMENCEMENT.

DATE OF APPLICATION: 4-11-18

PERMIT NUMBER 2018-04-040

PLEASE PRINT. The undersigned hereby applies for a permit to make installations as indicated below:

Project Address 5332 Hawford Circle, Belle Isle, FL 32809 X 32812

Property Owner William R Carter Phone 813-699-4250

Property Owner's Mailing Address 762 Saint Marks Ave, Apt 2D City Brooklyn

State NY Zip Code 11216-3721 Parcel Id Number: 20-23-30-9375-00-560

REQUIRED! To obtain this information, please visit <http://www.ocpaf.org/Searches/ParcelSearch.aspx>

Type of Building: Residential Commercial Other

- **REQUIRED!** Florida Product Approval Screen Printout from www.floridabuilding.org showing the Code Version
- **REQUIRED!** Florida Product Approval Installation Instructions from www.floridabuilding.org (not the manufacturer instructions)
- **REQUIRED!** Copies of your General Liability & Worker's Comp Insurance Certificate & State and Local Licenses

Please indicate the nature of work by completing the information below:

Number of Size-for-Size Windows: Number of Size-for-Size Doors: 1 Job Valuation: 1,406.00

I hereby certify that the above is true and correct to the best of my knowledge and make Application for Permit as outlined above, and if same is granted I agree to conform to all Florida Building Code Regulations and City Ordinances regulating same and in accordance with plans submitted. The issuance of this permit does not grant permission to violate any applicable Town and/or State of Florida codes and/or ordinances. By signing below, I recognize Republic Services is by legal contract the sole authorized provider of garbage, recycling, yard waste, and commercial garbage and construction debris collection and disposal services with the city limits of the City. Contractors, homeowners and commercial businesses may contact Republic Services at 407-293-8000 to setup accounts for Commercial, Construction Roll Off, or other services needed. Rates are fixed by contract and are available at City Hall or from Republic Services. The City enforces the contract through its code enforcement office. Failure to comply will result in a stop work order.

BY SIGNING THIS APPLICATION, YOU ARE CERTIFYING THAT YOU ARE ACTING AS THE OWNER'S AGENT FOR THIS PERMIT:

LICENSE HOLDER SIGNATURE D Miller LICENSE # CBC 1258205
 LICENSE HOLDER NAME Dallas Miller COMPANY NAME D & D Garage Doors
 Street Address 1177 Cattleman Road
 City Sarasota State FL Zip Code 34232 Phone Number 941-371-7212
 Email Address dallas@danddgaragedoors.com

Building Official: SM Date 4-16-18
 Verified Contractor's Licenses & Insurance are on file (SD) Date 4-16-18

Zoning Fee \$ 0
 Permit Fee \$ 29.-
 2.5 Review Fee \$ 14.50
 Florida Surcharge \$ 4. min
 Total Permit Fee \$ 47.50

1ST IK 25
 4
 29 + 2
 14.50
 43.50

PAID
 4-20-2018
 UISA 9434



City of Belle Isle
 Universal Engineering Sciences 3532 Maggie Blvd., Orlando, FL 32811
 Tel 407-581-8161 * Fax 407-581-0313 * www.universalengineering.com

Product Approval Form

DATE: 4-11-18

PERMIT # _____

PROJECT ADDRESS 5332 Hawford Circle, Belle Isle, FL _____ 32809 X 32812

As required by Florida Statue 553.842 and Florida Administrative Code 9B-72m, please provide the information and approval numbers of the building components listed below if they will be utilized on the building or structure. FL Approved products are listed online at www.floridabuilding.org or can be obtained from the local product supplier. The following information must be turned in with permit application and available onsite for inspections:

1. This Product Approval Cover Sheet
2. Internet screen from FloridaBuilding.org showing PA#, approval and code edition stamped
3. Manufacturer's *installation* details from FloridaBuilding.org and requirements for each product stamped

Product Type	Manufacturer	Model/Series	FL Product Approval #	Product Type	Manufacturer	Model/Series	FL Product Approval #
EXTERIOR DOORS				WALL PANELS			
Swinging				Sliding			
Sliding				Soffits			
Sectional/Rollup	<i>Cloray</i>	<i>73-Value</i>	<i>15279.20</i>	Storefront			
Other				Glass Block			
				Other			
WINDOWS				ROOFING PRODUCTS			
Single/Dbi Hung				Asphalt Shingles			
Horizontal Slider				Non Struct Metal			
Casement				Roofing Tiles			
Fixed				Single Ply Roof			
Mullion				Underlayment			
Skylights				Other			
Other							
STRUCTURAL COMPONENTS				OTHER			
Wood Connectors							
Wood Anchors							
Truss Plates							
Insulation Forms							
Lintels							
Other							

It is the applicant's responsibility to verify that specific products have been installed in accordance with their limitations and with the minimum required design pressures for the structure. Specific compliance will be verified during field inspections.

Applicant Signature *Geiny Davis*

Date 4-11-18



[BCIS Home](#) |
 [Log In](#) |
 [User Registration](#) |
 [Hot Topics](#) |
 [Submit Surcharge](#) |
 [Stats & Facts](#) |
 [Publications](#) |
 [FBC Staff](#) |
 [BCIS Site Map](#) |
 [Links](#) |
 [Search](#)



Product Approval
USER: Public User

[Product Approval Menu](#) >
 [Product or Application Search](#) >
 [Application List](#) >
 Application Detail



FL #	FL15279-R5												
Application Type	Revision												
Code Version	2017												
Application Status	Approved												
Comments	reapply 11/28/17												
Archived	<input type="checkbox"/>												
Product Manufacturer	Clopay Building Products Company												
Address/Phone/Email	8585 Duke Blvd. Mason, OH 45040 (513) 770-6062 mwesterfield@clopay.com												
Authorized Signature	Scott Hamilton shamilton@clopay.com												
Technical Representative													
Address/Phone/Email													
Quality Assurance Representative													
Address/Phone/Email													
Category	Exterior Doors												
Subcategory	Sectional Exterior Door Assemblies												
Compliance Method	Certification Mark or Listing												
Certification Agency	Intertek Testing Services NA, Inc.												
Validated By	Gary Pfoehler <input checked="" type="checkbox"/> Validation Checklist - Hardcopy Received												
Referenced Standard and Year (of Standard)	<table border="0"> <thead> <tr> <th>Standard</th> <th>Year</th> </tr> </thead> <tbody> <tr> <td>ANSI/DASMA 108</td> <td>2005</td> </tr> <tr> <td>ANSI/DASMA 115</td> <td>2005</td> </tr> <tr> <td>ASTM E1886</td> <td>2002</td> </tr> <tr> <td>ASTM E1996</td> <td>2002</td> </tr> <tr> <td>ASTM E330</td> <td>2002</td> </tr> </tbody> </table>	Standard	Year	ANSI/DASMA 108	2005	ANSI/DASMA 115	2005	ASTM E1886	2002	ASTM E1996	2002	ASTM E330	2002
Standard	Year												
ANSI/DASMA 108	2005												
ANSI/DASMA 115	2005												
ASTM E1886	2002												
ASTM E1996	2002												
ASTM E330	2002												
Equivalence of Product Standards Certified By	Florida Licensed Professional Engineer or Architect FL15279 R5 Equiv 20170809 - FBC - DASMA 108 equiv.pdf FL15279 R5 Equiv 20170809 - FBC - DASMA 115 equiv.pdf												
Product Approval Method	Method 1 Option A												
Date Submitted	08/10/2017												
Date Validated	11/29/2017												

Date Pending FBC Approval

Date Approved

12/05/2017

Summary of Products

Go to Page of 8

FL #	Model, Number or Name	Description
15279.1	001 W3-09 DSIE-1A171: 2050, 2051, 2053, 4050, 4051, 4053, 62, 64, 65, 62G, 62LG, 64G, SDP38, SFL38, SRP38, 134, 135, 136, 6130, 6131, 6133	1-3/8" Double-skin Insulated EPS (exterior skin 27 ga. min.; interior skin 29 ga. min.) Single-Car (up to 9'0" wide) WINDCODE® W3 Garage Door
Limits of Use Approved for use in HVHZ: No Approved for use outside HVHZ: Yes Impact Resistant: N/A Design Pressure: +20 PSF/-20 PSF Other: The OPTIONAL glazing available for this product meets the wind load requirements of the building code but DOES NOT meet the Impact resistant requirement for windborne debris regions. The product without glazing DOES comply with the impact resistant requirement for windborne debris regions (ref 1609.1.4 FBC).		Certification Agency Certificate FL15279_R5_C_CAC Letter with proof of contract and proof of inspection.pdf FL15279_R5_C_CAC W3 Listing Intertek.pdf Quality Assurance Contract Expiration Date 05/21/2028 Installation Instructions FL15279_R5_II_101655-Rev12.pdf Verified By: Intertek Testing Services NA, Inc. Created by Independent Third Party: Evaluation Reports Created by Independent Third Party:
15279.2	002 W3-09 DSIE-1A471: GD1SP, GR1SP, GD1LP, GR1LP, AR1SP, AR1LP, ED1SP, ED1LP, 4132, 2132, 6132, SFC38, MFC38	Gallery/Artistry/Expressions: 1-3/8" Double-skin Insulated EPS (exterior skin 27 ga. min.; interior skin 27 ga. min.) Single-Car (up to 9'0" wide) WINDCODE® W3 Garage Door
Limits of Use Approved for use in HVHZ: No Approved for use outside HVHZ: Yes Impact Resistant: N/A Design Pressure: +20 PSF/-21 PSF Other: The OPTIONAL glazing available for this product meets the wind load requirements of the building code but DOES NOT meet the Impact resistant requirement for windborne debris regions. The product without glazing DOES comply with the impact resistant requirement for windborne debris regions (ref 1609.1.4 FBC).		Certification Agency Certificate FL15279_R5_C_CAC Letter with proof of contract and proof of inspection.pdf FL15279_R5_C_CAC W3 Listing Intertek.pdf Quality Assurance Contract Expiration Date 05/21/2028 Installation Instructions FL15279_R5_II_103952-Rev01.pdf Verified By: Intertek Testing Services NA, Inc. Created by Independent Third Party: Evaluation Reports Created by Independent Third Party:
15279.3	003 W3-09 DSIU-1A171: 9130, 9131, 9133, HDPL13, HDPF13, HDPL13, 7130, 7131, 7133, 8130, 8131, 8133	Double-skin Insulated PUR (exterior skin 27 ga. min.; interior skin 27 ga. min.) Single-Car (up to 9'0" wide) WINDCODE® W3 Garage Door
Limits of Use Approved for use in HVHZ: No Approved for use outside HVHZ: Yes Impact Resistant: N/A Design Pressure: +20 PSF/-20 PSF Other: The OPTIONAL glazing available for this product meets the wind load requirements of the building code but DOES NOT meet the Impact resistant requirement for windborne debris regions. The product without glazing DOES comply with the impact resistant requirement for windborne debris regions (ref 1609.1.4 FBC).		Certification Agency Certificate FL15279_R5_C_CAC Letter with proof of contract and proof of inspection.pdf FL15279_R5_C_CAC W3 Listing Intertek.pdf Quality Assurance Contract Expiration Date 05/21/2028 Installation Instructions FL15279_R5_II_104175-Rev01.pdf Verified By: Intertek Testing Services NA, Inc. Created by Independent Third Party: Evaluation Reports Created by Independent Third Party:
15279.4	004 W3-16 DSIE-1A171: 2050, 2051, 2053, 4050, 4051, 4053, 62, 64, 65, 62G, 62LG, 64G, SDP38, SFL38, SRP38, 134, 135, 136, 6130, 6131, 6133	1-3/8" Double-skin Insulated EPS (exterior skin 27 ga. min.; interior skin 29 ga. min.) Double-Car (9'2" to 16'0" wide) WINDCODE® W3 Garage Door
Limits of Use Approved for use in HVHZ: No Approved for use outside HVHZ: Yes Impact Resistant: N/A Design Pressure: +20 PSF/-21 PSF Other: The OPTIONAL glazing available for this product meets the wind load requirements of the building code but DOES NOT meet the impact resistant requirement for windborne debris regions. The product without glazing DOES comply with the impact resistant requirement for windborne debris regions (ref 1609.1.4 FBC).		Certification Agency Certificate FL15279_R5_C_CAC Letter with proof of contract and proof of inspection.pdf FL15279_R5_C_CAC W3 Listing Intertek.pdf Quality Assurance Contract Expiration Date 05/21/2028 Installation Instructions FL15279_R5_II_101820-Rev13.pdf Verified By: Intertek Testing Services NA, Inc. Created by Independent Third Party: Evaluation Reports Created by Independent Third Party:
15279.5		

15279.19	019 W4-16 DSIUO-1K479: Canyon Ridge/Brookstone	Double Skin Insulated PUR (exterior skin 27 ga. mln.; interior skin 27ga. mln.) with Overlay Double-Car (9'2" to 16'0" wide) WINDCODE® W4 Garage Door
<p>Limits of Use Approved for use in HVHZ: No Approved for use outside HVHZ: Yes Impact Resistant: N/A Design Pressure: +25.5 PSF/-25.5 PSF Other: The OPTIONAL glazing available for this product meets the wind load requirements of the building code but DOES NOT meet the impact resistant requirement for windborne debris regions. The product without glazing DOES comply with the impact resistant requirement for windborne debris regions (ref 1609.1.4 FBC).</p>		<p>Certification Agency Certificate FL15279_R5_C_CAC Letter with proof of contract and proof of inspection.pdf FL15279_R5_C_CAC W4 Listing Intertek.pdf Quality Assurance Contract Expiration Date 05/21/2028 Installation Instructions FL15279_R5_II_104457-Rev02.pdf Verified By: Intertek Testing Services NA, Inc. Created by Independent Third Party: Evaluation Reports Created by Independent Third Party:</p>
15279.20	020 W4-16 PAN-2F153: 73, 1500, 75, 190, 84A, 94, 42, 48, 55, 4RST, 6RST, 4RSF, 6RSF, GD5S, GD5SV, GR5S, GR5SV, AR5S, AR5SV, ED5S, ED5SV	Steel Pan (min. 25 ga.) Double-Car (9'2" to 16'0" wide) WINDCODE® W4 Garage Door
<p>Limits of Use Approved for use in HVHZ: No Approved for use outside HVHZ: Yes Impact Resistant: No Design Pressure: +24 PSF/-24.5 PSF Other: The standard glazing available for this product meets the wind load requirements of the building code but DOES NOT meet the impact resistant requirement for windborne debris regions.</p>		<p>Certification Agency Certificate FL15279_R5_C_CAC Letter with proof of contract and proof of inspection.pdf FL15279_R5_C_CAC W4 Listing Intertek.pdf Quality Assurance Contract Expiration Date 05/21/2028 Installation Instructions FL15279_R5_II_101711-B-Rev15.pdf Verified By: Intertek Testing Services NA, Inc. Created by Independent Third Party: Evaluation Reports Created by Independent Third Party:</p>

Go to Page

Page 1 / 8

[Back](#) [Next](#)

Contact Us :: 2601 Blair Stone Road, Tallahassee FL 32399 Phone: 850-487-1824

The State of Florida is an AA/EEO employer. [Copyright 2007-2013 State of Florida.](#) :: [Privacy Statement](#) :: [Accessibility Statement](#) :: [Refund Statement](#)

Under Florida law, email addresses are public records. If you do not want your e-mail address released in response to a public-records request, do not send electronic mail to this entity. Instead, contact the office by phone or by traditional mail. If you have any questions, please contact 850.487.1395. *Pursuant to Section 455.275(1), Florida Statutes, effective October 1, 2012, licensees licensed under Chapter 455, F.S. must provide the Department with an email address if they have one. The emails provided may be used for official communication with the licensee. However email addresses are public record. If you do not wish to supply a personal address, please provide the Department with an email address which can be made available to the public. To determine if you are a licensee under Chapter 455, F.S., please click [here](#).



Credit Card
Safe





www.DandDGarageDoors.com

CBC1258205

NORTHEAST REGION

LAKE CITY / GAINESVILLE
(386) 754-3667
JACKSONVILLE
(904) 281-9199

CENTRAL REGION

OCALA-CLERMONT
(352) 243-9111
ORLANDO
(407) 331-0804
DAYTONA
(386) 673-1313
LAKELAND / WINTER HAVEN
(863) 965-2719

SEBRING / OKEECHOBEE
TITUSVILLE TO PALM BAY
(888) 435-0552

SOUTHWEST REGION

TAMPA / BROOKSVILLE
(813) 224-0123
SUN CITY / APOLLO BEACH
(813) 634-2742
SARASOTA / MANATEE
(941) 371-7242
VENICE
(941) 484-3733
NORTH PORT / ENGLEWOOD
(941) 423-8888

PT. CHARLOTTE / PUNTA GORDA
(941) 629-2400

CAPE CORAL / FT. MYERS
(239) 540-6888
BONITA SPRINGS / NAPLES
(239) 496-4478

SOUTHEAST REGION

VERO BEACH / WEST PALM
PORT ST. LUCIE
(888) 435-0552
TREASURE COAST
(800) 371-3667

Limited Power of Attorney

Date: 4-11-18

To: City of Belle Isle

I hereby name and appoint: Genny Davis, an agent of D&D Garage Doors to be my lawful attorney-in-fact to act for me to apply for, receipt for, sign for and do all things necessary to this appointment for:

The specific permit and application for work located at:

5332 Hawford Circle
(Street address)

(Legal description)
William R Carter
(Owner of property)

License Holder and Qualifier for D&D Garage Doors: Dallas L. Miller
State License Number: CBC1258205

Dallas Miller
Signature of License Holder

State of FLORIDA
County of Orange

The foregoing instrument was acknowledged before me this 11TH day of April, 20 18, by Dallas Miller, who is personally known to me or has produced _____ as Identification.

(Notary Seal)



VICTORIA CASTREJON
MY COMMISSION # FF 117213
EXPIRES: April 28, 2018
Bonded Thru Budget Notary Services

Victoria Castrejon
Signature of Notary

Victoria Castrejon
Printed Name of Notary

Property Record - 20-23-30-9375-00-560

Orange County Property Appraiser • <http://www.ocpafl.org>

Property Summary

Property Name
5332 Hawford Cir
Names
Carter William R
Municipality
BI - Belle Isle
Property Use
0103 - Single Fam Class III

Mailing Address
C/O Sharon Black Carter
762 Saint Marks Ave Apt 2D
Brooklyn, NY 11216-3721
Physical Address
5332 Hawford Cir
Orlando, FL 32812



QR Code For Mobile Phone



302320937500560 08/24/2006

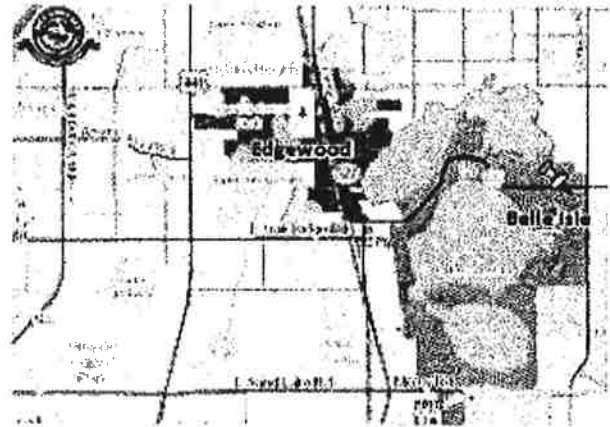

Value and Taxes

Historical Value and Tax Benefits

Tax Year Values	Land	Building(s)	Feature(s)	Market Value	Assessed Value
2017 <input checked="" type="checkbox"/> MKT	\$65,000	+ \$183,105	+ \$20,000 =	\$268,105 (1.9%)	\$268,105 (1.9%)
2016 <input checked="" type="checkbox"/> MKT	\$65,000	+ \$177,668	+ \$20,500 =	\$263,168 (4.7%)	\$263,168 (7.5%)
2015 <input checked="" type="checkbox"/> MKT	\$65,000	+ \$165,335	+ \$21,000 =	\$251,335 (13%)	\$244,730 (10%)
2014 <input checked="" type="checkbox"/> MKT	\$80,000	+ \$127,682	+ \$14,800 =	\$222,482	\$222,482

Tax Year Benefits

Tax Savings



**STATE OF FLORIDA
DEPARTMENT OF BUSINESS AND PROFESSIONAL REGULATION**

**CONSTRUCTION INDUSTRY LICENSING BOARD
1940 NORTH MONROE STREET
TALLAHASSEE FL 32399-0783**

(850) 487-1395

**MILLER, DALLAS LEE
D & D GARAGE DOORS INC
1177 CATTLEMAN ROAD
SARASOTA FL 34232**

Congratulations! With this license you become one of the nearly one million Floridians licensed by the Department of Business and Professional Regulation. Our professionals and businesses range from architects to yacht brokers, from boxers to barbeque restaurants, and they keep Florida's economy strong.

Every day we work to improve the way we do business in order to serve you better. For information about our services, please log onto www.myfloridalicense.com. There you can find more information about our divisions and the regulations that impact you, subscribe to department newsletters and learn more about the Department's initiatives.

Our mission at the Department is: License Efficiently, Regulate Fairly. We constantly strive to serve you better so that you can serve your customers. Thank you for doing business in Florida, and congratulations on your new license!



DETACH HERE

RICK SCOTT, GOVERNOR

KEN LAWSON, SECRETARY

**STATE OF FLORIDA
DEPARTMENT OF BUSINESS AND PROFESSIONAL REGULATION
CONSTRUCTION INDUSTRY LICENSING BOARD**

LICENSE NUMBER	
CBC1258205	

The BUILDING CONTRACTOR
Named below IS CERTIFIED
Under the provisions of Chapter 489 FS.
Expiration date: AUG 31, 2018

**MILLER, DALLAS LEE
D & D GARAGE DOORS INC
1177 CATTLEMAN ROAD
SARASOTA FL 34232**



ISSUED: 05/23/2016

DISPLAY AS REQUIRED BY LAW

SEQ # L1605230000861

This local business tax receipt is in addition to and not in lieu of any other tax required by law or municipal ordinance. Businesses are subject to regulation of zoning, health and other local authorities. This receipt is valid from October 1 through September 30 of receipt year. Delinquent penalty is added October 1.

2017 EXPIRES 9/30/2018 1801-1086714
1801 CERT GENERAL CONTR \$30.00 10 EMPLOYEE 5000 BUSINESS OFFICE \$30.00 10 EMPLOYEE

TOTAL TAX \$60.00
PREVIOUSLY PAID \$60.00
TOTAL DUE \$0.00

MILLER DALLAS

D & D GARAGE DOORS INC
1177 CATTLEMAN RD
SARASOTA FL 34232

1723 PREMIER ROW
U - ORLANDO, 32809

PAID: \$60.00 0098-00785773 7/24/2017

Scott Randolph, Tax Collector Local Business Tax Receipt Orange County, Florida.

This local business tax receipt is in addition to and not in lieu of any other tax required by law or municipal ordinance. Businesses are subject to regulation of zoning, health and other local authorities. This receipt is valid from October 1 through September 30 of receipt year. Delinquent penalty is added October 1.

2017 EXPIRES 9/30/2018 1801-1086714
1801 CERT GENERAL CONTR \$30.00 10 EMPLOYEE 5000 BUSINESS OFFICE \$30.00 10 EMPLOYEE

TOTAL TAX \$60.00
PREVIOUSLY PAID \$60.00
TOTAL DUE \$0.00

MILLER DALLAS

D & D GARAGE DOORS INC
1177 CATTLEMAN RD
SARASOTA FL 34232

1723 PREMIER ROW
U - ORLANDO, 32809

PAID: \$60.00 0098-00785773 7/24/2017



This receipt is official when validated by the Tax Collector.



CERTIFICATE OF LIABILITY INSURANCE

DATE (MM/DD/YYYY)

12/6/2017

THIS CERTIFICATE IS ISSUED AS A MATTER OF INFORMATION ONLY AND CONFERS NO RIGHTS UPON THE CERTIFICATE HOLDER. THIS CERTIFICATE DOES NOT AFFIRMATIVELY OR NEGATIVELY AMEND, EXTEND OR ALTER THE COVERAGE AFFORDED BY THE POLICIES BELOW. THIS CERTIFICATE OF INSURANCE DOES NOT CONSTITUTE A CONTRACT BETWEEN THE ISSUING INSURER(S), AUTHORIZED REPRESENTATIVE OR PRODUCER, AND THE CERTIFICATE HOLDER.

IMPORTANT: If the certificate holder is an ADDITIONAL INSURED, the policy(ies) must be endorsed. If SUBROGATION IS WAIVED, subject to the terms and conditions of the policy, certain policies may require an endorsement. A statement on this certificate does not confer rights to the certificate holder in lieu of such endorsement(s).

PRODUCER Ben Brown Insurance Agency 3731 S Tuttle Ave Sarasota FL 34239-6410		CONTACT NAME: Kristi Adams PHONE (A/C, No, Ext): (941) 366-9373 FAX (A/C, No): (941) 365-3143 E-MAIL ADDRESS: certificates@benbrownins.com - Jessica	
INSURED D & D Garage Doors, Inc. 1177 Cattlemen Rd Sarasota FL 34232		INSURER(S) AFFORDING COVERAGE	
		INSURER A: National Trust Ins Co	NAIC # 20141
		INSURER B: Monroe Guaranty Ins Co	32506
		INSURER C:	
		INSURER D:	
		INSURER E:	
		INSURER F:	

COVERAGES **CERTIFICATE NUMBER:** 18/1 All **REVISION NUMBER:**

THIS IS TO CERTIFY THAT THE POLICIES OF INSURANCE LISTED BELOW HAVE BEEN ISSUED TO THE INSURED NAMED ABOVE FOR THE POLICY PERIOD INDICATED. NOTWITHSTANDING ANY REQUIREMENT, TERM OR CONDITION OF ANY CONTRACT OR OTHER DOCUMENT WITH RESPECT TO WHICH THIS CERTIFICATE MAY BE ISSUED OR MAY PERTAIN, THE INSURANCE AFFORDED BY THE POLICIES DESCRIBED HEREIN IS SUBJECT TO ALL THE TERMS, EXCLUSIONS AND CONDITIONS OF SUCH POLICIES. LIMITS SHOWN MAY HAVE BEEN REDUCED BY PAID CLAIMS.

INSR LTR	TYPE OF INSURANCE	ADDL SUBR INSD WVD	POLICY NUMBER	POLICY EFF (MM/DD/YYYY)	POLICY EXP (MM/DD/YYYY)	LIMITS
A	<input checked="" type="checkbox"/> COMMERCIAL GENERAL LIABILITY <input type="checkbox"/> CLAIMS-MADE <input checked="" type="checkbox"/> OCCUR <input checked="" type="checkbox"/> Contractual Liability <input checked="" type="checkbox"/> XCO GEN'L AGGREGATE LIMIT APPLIES PER: <input type="checkbox"/> POLICY <input checked="" type="checkbox"/> PRO. JECT <input type="checkbox"/> LOC OTHER:		GL0011328-8	1/1/2018	1/1/2019	EACH OCCURRENCE \$ 1,000,000 DAMAGE TO RENTED PREMISES (Ea occurrence) \$ 100,000 MED EXP (Any one person) \$ 5,000 PERSONAL & ADV INJURY \$ 1,000,000 GENERAL AGGREGATE \$ 2,000,000 PRODUCTS - COMP/OP AGG \$ 2,000,000 Employee Benefits \$ 1,000,000
B	AUTOMOBILE LIABILITY <input checked="" type="checkbox"/> ANY AUTO <input type="checkbox"/> ALL OWNED AUTOS <input type="checkbox"/> SCHEDULED AUTOS <input checked="" type="checkbox"/> HIRED AUTOS <input checked="" type="checkbox"/> NON-OWNED AUTOS		CA10000843-02	1/1/2018	1/1/2019	COMBINED SINGLE LIMIT (Ea accident) \$ 1,000,000 BODILY INJURY (Per person) \$ BODILY INJURY (Per accident) \$ PROPERTY DAMAGE (Per accident) \$ Uninsured Motorist Liab / BI \$
A	<input checked="" type="checkbox"/> UMBRELLA LIAB <input checked="" type="checkbox"/> OCCUR <input type="checkbox"/> EXCESS LIAB <input type="checkbox"/> CLAIMS-MADE <input type="checkbox"/> DED <input checked="" type="checkbox"/> RETENTION \$ 0		UMB10002008101	1/1/2018	1/1/2019	EACH OCCURRENCE \$ 2,000,000 AGGREGATE \$ 2,000,000
	WORKERS COMPENSATION AND EMPLOYERS' LIABILITY ANY PROPRIETOR/PARTNER/EXECUTIVE OFFICER/MEMBER EXCLUDED? (Mandatory in NH) <input type="checkbox"/> Y/N <input checked="" type="checkbox"/> N/A If yes, describe under DESCRIPTION OF OPERATIONS below					PER STATUTE OTH-ER E.L. EACH ACCIDENT \$ E.L. DISEASE - EA EMPLOYEE \$ E.L. DISEASE - POLICY LIMIT \$

DESCRIPTION OF OPERATIONS / LOCATIONS / VEHICLES (ACORD 101, Additional Remarks Schedule, may be attached if more space is required)
 Garage door installation & maintenance. - Qualifier: Dallas Miller, State license #CBC1258205

CERTIFICATE HOLDER (407) 240-2222 City of Belle Isle 1600 Nela Ave Bell Isle, FL 32809	CANCELLATION SHOULD ANY OF THE ABOVE DESCRIBED POLICIES BE CANCELLED BEFORE THE EXPIRATION DATE THEREOF, NOTICE WILL BE DELIVERED IN ACCORDANCE WITH THE POLICY PROVISIONS. AUTHORIZED REPRESENTATIVE Ryan Brown/KIM 
---	--

© 1988-2014 ACORD CORPORATION. All rights reserved.

MODELS	1 3/8" THICK STYRENE		
CLOPAY/GALLERY	GD1SP, GR1SP	GD1LP, GR1LP	4132, 2132
HOLMES/ARTISTRY	AR1SP	AR1LP	6132
IDEAL/EXPRESSIONS	ED1SP	ED1LP	SFC38, MFC38
	SHORT PANEL	LONG PANEL	FLUSH

THIS DOOR MEETS OR EXCEEDS THE DESIGN LOADS FOR THE ULTIMATE WIND SPEEDS LISTED BELOW ACCORDING TO THE FLORIDA BUILDING CODE OR THE INTERNATIONAL BUILDING CODE (BASED ON ASCE7-10) FOR THE FOLLOWING CONDITIONS: 1) ENCLOSED BUILDING, 2) DOOR HAS 2' OF WIDTH IN BUILDING'S END ZONE, 3) ANY ROOF SLOPE, AND 4) TESTING IN ACCORDANCE WITH ANSI/DASMA 108. SITE-SPECIFIC CALCULATIONS BY A QUALIFIED DESIGN PROFESSIONAL MAY DIFFER.

ULTIMATE WIND SPEED (MPH)	120	125	140
EXPOSURE CATEGORY	B, C	B, C	B
MEAN ROOF HEIGHT	25'	15'	30'

REV	DATE	ECD NUMBER	APPROVED	DESCRIPTION
00	10/15/07		SH	INITIAL RELEASE
01	01/31/12		SH	REVISED WIND SPEED TABLE FOR ASCE7-10.

OPTIONAL WINDOW LITES DSB GLASS OR 1/8" ACRYLIC AVAILABLE. OPTIONAL ACRYLIC GLAZING IS PLASKOLITE OPTIX OR LUCITE CP APPROVED CC2 PLASTIC IN ACCORDANCE WITH IBC/FBC 2606. (SEE SECTION B-B)

SHORT LITES SHOWN, LONG LITES ALSO AVAIL. (LONG LITES FRAME NOT TO EXCEED 42" WIDE x 16" TALL)

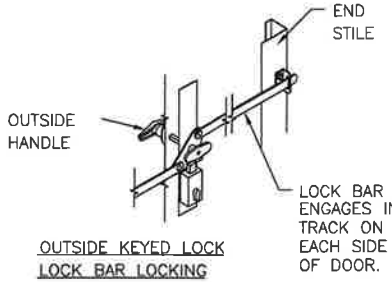
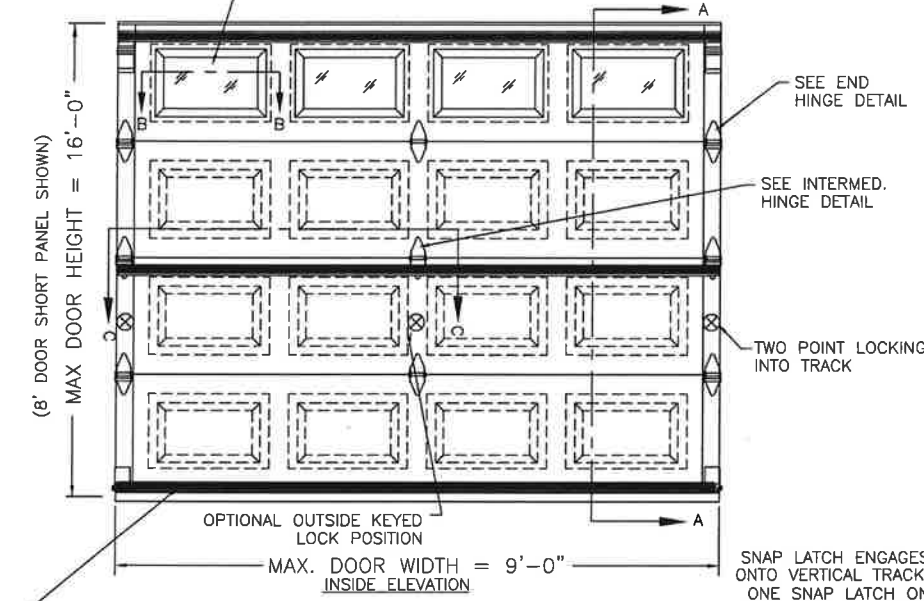

VERTICAL JAMB ATTACHMENT (C-90 BLOCK OR 2000 PSI MIN. CONCRETE COLUMN):
3/8"x4" SLEEVE ANCHORS ON 24" CENTERS (BOTH C-90 BLOCK OR 2000 PSI MIN. CONCRETE) OR 1/4"x4" TAPCON SCREWS ON 24" CENTERS (2000 PSI MIN. CONCRETE). WASHERS INCLUDED WITH SLEEVE ANCHORS. 1" O.D. WASHERS REQUIRED WITH TAPCONS. ANCHORS MAY BE COUNTERSUNK (BUT NOT REQUIRED) TO PROVIDE A FLUSH MOUNTING SURFACE. HORIZONTAL JAMBS DO NOT TRANSFER LOAD.

VERTICAL JAMB ATTACHMENT (WOOD FRAME BUILDINGS):
1/2"x3" LAG SCREWS ON 24" CENTERS. 1" O.D. WASHER REQUIRED. LAG SCREWS MAY BE COUNTERSUNK (BUT NOT REQUIRED) TO PROVIDE A FLUSH MOUNTING SURFACE. HORIZONTAL JAMBS DO NOT TRANSFER LOAD.

NOTE: TRACK CONFIGURATION ABOVE THE DOOR OPENING DOES NOT AFFECT THE WIND LOAD RATING OF THIS DOOR. HORIZONTAL TRACK SUPPORT BY DOOR INSTALLER (TO SUIT)

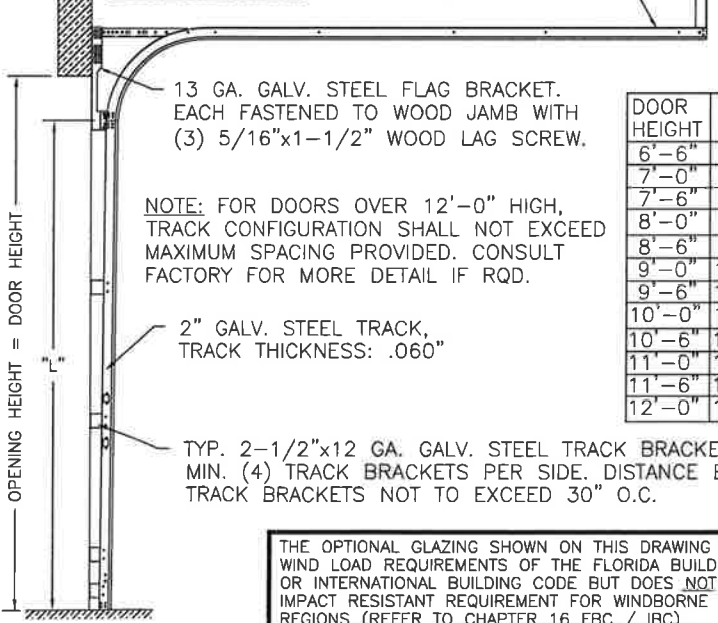

DOOR HEIGHT "H"	"L"
6'-6"	70"
7'-0"	76"
7'-6"	82"
8'-0"	88"
8'-6"	94"
9'-0"	100"
9'-6"	106"
10'-0"	112"
10'-6"	118"
11'-0"	124"
11'-6"	130"
12'-0"	136"

THE OPTIONAL GLAZING SHOWN ON THIS DRAWING MEETS THE WIND LOAD REQUIREMENTS OF THE FLORIDA BUILDING CODE OR INTERNATIONAL BUILDING CODE BUT DOES NOT MEET THE IMPACT RESISTANT REQUIREMENT FOR WINDBORNE DEBRIS REGIONS (REFER TO CHAPTER 16 FBC / IBC).

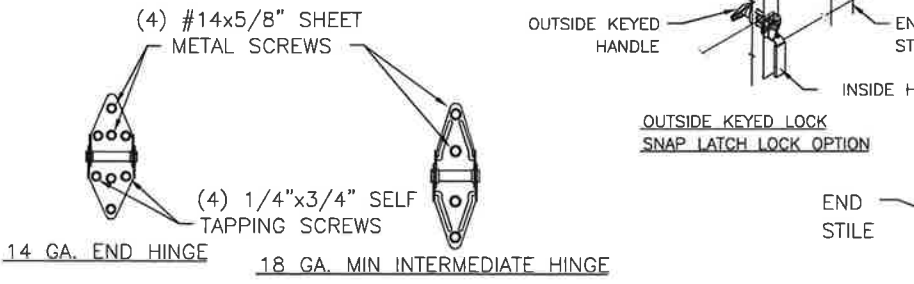

SECT C-C

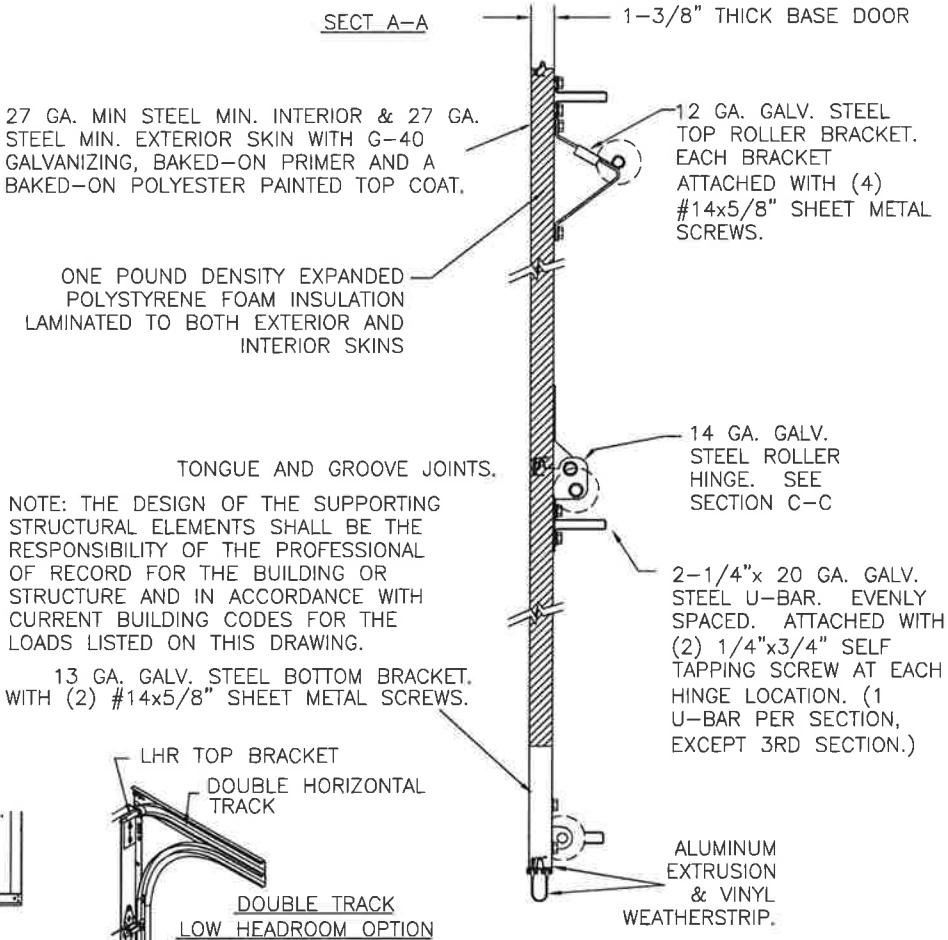
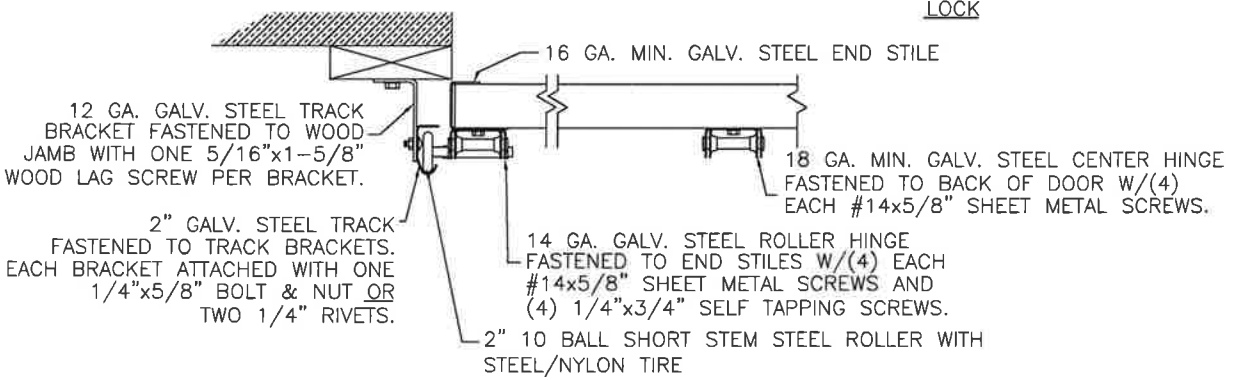

NOTE: THE DESIGN OF THE SUPPORTING STRUCTURAL ELEMENTS SHALL BE THE RESPONSIBILITY OF THE PROFESSIONAL OF RECORD FOR THE BUILDING OR STRUCTURE AND IN ACCORDANCE WITH CURRENT BUILDING CODES FOR THE LOADS LISTED ON THIS DRAWING.

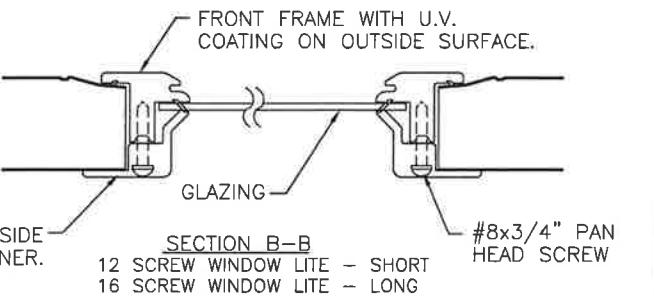

DESIGN ENGINEER: MARK WESTERFIELD, P.E.
FLORIDA P.E. #48495, NC P.E. #23832, TEXAS P.E. #91513
DESIGN LOADS: +20.0 P.S.F. & -21.0 P.S.F.
TEST LOADS: +30.0 P.S.F. & -31.5 P.S.F.



CLOPAY BUILDING PRODUCTS COMPANY
8585 DUKE BOULEVARD
CINCINNATI, OH 45040
(513) 770-4800
Clopay Corporation All Rights Reserved.

MANUFACTURING PRODUCT CODE DSIE-1A471	WINDLOAD RATING W3	MAX. SIZE: 9'0" x 16'0"
DATE: 6/19/07	DESCRIPTION: GALLERY 1-3/8" EPS SC +20/-21 PSF	
DRAWN BY: BFA	DRAWING NUMBER: B 103952	VER: IBC
CHECKED BY:		