



BUILDING JOB SITE CARD

City of Belle Isle

WINDOW/DOOR PERMIT 2018-04-014

PERMIT MUST BE POSTED ON SITE

Permit Number: 2018-04-014

Issue Date: 04/05/2018

Site Address: 5256 Jade Circle - 32812

Parcel Number: 20-23-30-4395-00-320

Subdivision: na

Class: Residential

Description of Work: 2 Doors - size for size

Issued To: THE HOME DEPOT

Business Phone: 407 469-5599

Name: RAMDIAL, BOYSIE GANGA

Contractor License #: CRC046858

Payment Date & Method:

4-5-18 VISA 5842

\$ 65.50

Schedule Inspections via Email at: BDscheduling@universalengineering.com

SCHEDULE INSPECTIONS BY 4PM CUT OFF TIME

Inspection Results Will Be Sent Out the Following Business Day

"WARNING TO OWNER: YOUR FAILURE TO RECORD A NOTICE OF COMMENCEMENT MAY RESULT IN YOUR PAYING TWICE FOR IMPROVEMENTS TO YOUR PROPERTY. IF YOU INTEND TO OBTAIN FINANCING, CONSULT WITH YOUR LENDER OR AN ATTORNEY BEFORE RECORDING YOUR NOTICE OF COMMENCEMENT."

WINDOW/DOOR	INSPECTOR	DATE	COMMENTS
900 In-progress			
910 Final			

Inspection requests are to be emailed to BDscheduling@UniversalEngineering.com; a confirmation email will be sent back to you upon scheduling. Next-Day Inspection requests must be made by 4pm. Please include the following in your request: Permit #, project address, type of inspection, date of the requested inspection, a contact name & a contact phone number. AM or PM may be requested but cannot be guaranteed.



City of Belle Isle
 Universal Engineering Sciences 3532 Maggie Blvd., Orlando, FL 32811
 Tel 407-581-8161 * Fax 407-581-0313 * www.universalengineering.com

RECEIVED
 APR 04 2018

APPLICATION FOR SIZE-FOR-SIZE WINDOW / DOOR PERMIT

WARNING TO OWNER: YOUR FAILURE TO RECORD A NOTICE OF COMMENCEMENT MAY RESULT IN YOUR PAYING TWICE FOR IMPROVEMENTS TO YOUR PROPERTY. A NOTICE OF COMMENCEMENT MUST BE RECORDED AND POSTED ON THE JOB SITE BEFORE THE FIRST INSPECTION. IF YOU INTEND TO OBTAIN FINANCING, CONSULT WITH YOUR LENDER OR AN ATTORNEY BEFORE RECORDING YOUR NOTICE OF COMMENCEMENT.

DATE OF APPLICATION: _____ PERMIT NUMBER 2018-04-014

PLEASE PRINT. The undersigned hereby applies for a permit to make installations as indicated below:

Project Address 5256 Jade Cir., Belle Isle, FL 32809 X 32812
 Property Owner David Romano Phone 321-278-1257
 Property Owner's Mailing Address 5256 Jade Cir. City Belle Isle
 State FL Zip Code 32812 Parcel Id Number: 20-23-30-4395-00-320

REQUIRED! To obtain this information, please visit <http://www.ocpafl.org/Searches/ParcelSearch.aspx>

Type of Building: Residential Commercial Other

• REQUIRED! Florida Product Approval Form – NOTE: installation instructions must be posted on-site before your first inspection!!

Please indicate the nature of work by completing the information below:

Number of Size-for-Size Windows: _____ Number of Size-for-Size Doors: 2 Job Valuation: \$4,197

I hereby certify that the above is true and correct to the best of my knowledge and make Application for Permit as outlined above, and if same is granted I agree to conform to all Florida Building Code Regulations and City Ordinances regulating same and in accordance with plans submitted. The issuance of this permit does not grant permission to violate any applicable Town and/or State of Florida codes and/or ordinances. By signing below, I recognize Republic Services is by legal contract the sole authorized provider of garbage, recycling, yard waste, and commercial garbage and construction debris collection and disposal services with the city limits of the City. Contractors, homeowners and commercial businesses may contact Republic Services at 407-293-8000 to setup accounts for Commercial, Construction Roll Off, or other services needed. Rates are fixed by contract and are available at City Hall or from Republic Services. The City enforces the contract through its code enforcement office. Failure to comply will result in a stop work order.

BY SIGNING THIS APPLICATION, YOU ARE CERTIFYING THAT YOU ARE ACTING AS THE OWNER'S AGENT FOR THIS PERMIT:

LICENSE HOLDER SIGNATURE [Signature] LICENSE # CR20046858
 LICENSE HOLDER NAME Boysie Pambial COMPANY NAME THE Home Depot
 Street Address 9208 Florida Palm Drive
 City Tampa State FL Zip Code 33619 Phone Number 407-469-5599
 Email Address Rickie.Roberts@ExpeditePermit.com

Building Official: SM Date 4-4-18
 Verified Contractor's Licenses & Insurance are on file [Signature] Date 4-4-18

Zoning Fee	\$	<u>0</u>
Permit Fee	\$	<u>41.-</u>
Review Fee	\$	<u>20.50</u>
1% BCAIB Fee	\$	<u>2 min</u>
1.5% DCA Fee	\$	<u>2 min</u>
Total Permit Fee	\$	<u>65.50</u>

15K 16
 4x4
 25
 16
 41.50
 20.50
 61.50

NOCC
 PAID 4-5-18 VISA 5842

ATTORNEYS FEE - SECTION 173

2018-04-04

PERMITS NUMBER:

NOTICE OF COMMENCEMENT

The undersigned hereby gives notice that improvement will be made to certain real property, and to accordance with Chapter 713, Florida Statutes, the following information is provided in this Notice of Commencement: 20252922000000200

- DESCRIPTION OF PROPERTY (Legal description of the property & street address, if available) TRACT/PLOT/BLK/IND: 20252922000000200
 SUBDIVISION TEED CONDOS BLOCK _____ TRACT _____ LOT _____ BLDG D UNIT 20
1042 PLANTATION DRIVE, KISSIMMEE, FL 34741
- GENERAL DESCRIPTION OF IMPROVEMENT: REPLACE WINDOWS
- OWNER INFORMATION OR LESSEE INFORMATION IF THE LESSEE CONTRACTED FOR THE IMPROVEMENT:
 - Name and address: CARMEN GARCIA, 1042 PLANTATION DR, KISSIMMEE, FL 34741
 - Interest in property: OWNER
 - Address and address of the vendor (contractor or different from Owner listed above): _____
 - CONTRACTOR'S NAME: THE HOME DEPOT
 Contractor's address: 9288 Florida Palms Drive, Tampa, FL 33616 Phone number: 813-626-7648
 - SECURITY (If applicable, a copy of the payment bond is attached): N/A
 - Name and address: _____
 - Phone number: _____
 - LENDER'S NAME: N/A
 Lender's address: _____ Phone number: _____
- Persons within the State of Florida designated by Owner upon whom notices or other documents may be served as provided by Sections 713.13 (1) (a) 7, Florida Statutes:
 - Name and address: _____
 - Phone numbers of designated persons: _____
 - a. In addition to himself or herself, Owner designates _____ of _____ to receive a copy of the Lender's Notice as provided in Section 713.13 (1) (b), Florida Statute.
 - Phone number of person so designated by Owner: _____
- Expiration date of notice of commencement (the expiration date may not be before the completion of construction and final payment to the contractor, but will be 1 year from the date of recording unless a different date is specified): _____, 20_____

WARNING TO OWNER: ANY PAYMENTS MADE BY THE OWNER AFTER THE EXPIRATION OF THE NOTICE OF COMMENCEMENT ARE CONSIDERED IMPROPER PAYMENTS UNDER CHAPTER 713, PART I, SECTION 713.13, FLORIDA STATUTES, AND CAN RESULT IN YOUR PAYING TWICE FOR IMPROVEMENTS TO YOUR PROPERTY. A NOTICE OF COMMENCEMENT MUST BE RECORDED AND POSTED ON THE JOB SITE BEFORE THE FIRST INSPECTION. IF YOU INTEND TO OBTAIN FINANCING, CONSULT WITH YOUR LENDER OR AN ATTORNEY BEFORE COMMENCING WORK OR RECORDED YOUR NOTICE OF COMMENCEMENT.

Under penalty of perjury, I declare that I have read the foregoing notice of commencement and that the facts stated therein are true to the best of my knowledge and belief.

Carmen Garcia CARMEN GARCIA
 (Signature of Owner or Lessee, or Owner's or Lessee's Authorized Officer/Director/Partner/Manager) (Print Name and Provide Signatory's Title/Office)

State of FLORIDA
 County of ORANGE

The foregoing instrument was acknowledged before me this 3 day of APRIL, 2018
 by CARMEN GARCIA as OWNER
 for SELF (name of party or, behalf of whom instrument was executed)
 (Type of authority, e.g. officer, trustee, attorney in fact)

Personally Known OR PROBABLY KNOWN Type of Identification Produced _____
 NOTARY PUBLIC
STATE OF FLORIDA
Comm# FF428885
Expires 10/19/2019
 (Print, Type, or Stamp Commissioned Name of Notary Public)



LIMITED POWER OF ATTORNEY

I, Boysie Ramdial (Name of Home Depot Qualifier), license # CRC046858, hereinafter referred to as the "License Holder," the qualifying agent of The Home Depot, hereby appoint the following persons as Attorney-in-Fact of the License Holder/The Home Depot, who shall act as my agent with respect to only the following matters (a) signing and submitting building permit applications, (b) obtaining building permits, and (c) obtaining the certificate of occupancy from Belle Isle (pertinent city/county/state) on behalf of the License Holder/The Home Depot:

Brian Kirby

Tim O'Malley

Erick DeDios

Aaron Hallich

David Weed

Christine O'Malley

LICENSE HOLDER:

Sign: Boysie Ramdial

Print Name: Boysie Ramdial

Date: _____

Title: Regional Compliance Manager

Company Name: Home Depot USA

Mailing Address: 1216 Isben Ave

Orlando, FL 32809

Telephone No.: 404-593-4879

Fax No.: _____

State of: Florida

County of: Orange

DAVID ROMANO
5256 TADE CIRCLE
BELLE ISLE, FL 32812

WITNESSES (Two signatures required):

Sign: [Signature]

Print Name: Robbie Roberts

Date: 4/3/18

Sign: [Signature]

Print Name: Amber Holman

Date: 4/3/18

This Limited Power of Attorney is non-durable, meaning it ceases effectiveness if the principal becomes incapacitated.

If I have designated more than one agent, the agents are permitted to act separately.

() This power of attorney and authorization shall expire on _____

(X) This power of attorney and authorization shall continue in full force and effect until I deliver to you a letter revoking the power or a new Limited Power of Attorney form replacing any previous authorization.

The foregoing instrument was acknowledged before me this 3 day of APRIL, 2018, by Boysie Ramdial, the Qualifier of The Home Depot, a _____ corporation, on behalf of the corporation.

[Signature]
Notary Public

Jonathon Thomas
NOTARY PUBLIC
STATE OF FLORIDA
Comm# GG141189
Expires 9/18/2021

Commission Expires: _____



Product Approval
USER: Public User

[Product Approval Menu](#) >
 [Product or Application Search](#) >
 [Application List](#) >
 Application Detail



FL #	FL7612-R17						
Application Type	Revision						
Code Version	2017						
Application Status	Approved						
	*Approved by DBPR. Approvals by DBPR shall be reviewed and ratified by the POC and/or the Commission if necessary.						
Comments							
Archived	<input type="checkbox"/>						
Product Manufacturer	Simonton/Ply Gem Windows						
Address/Phone/Email	3948 Townsfair Way, Suite 200 Suite 200 Columbus, OH 43219 (614) 532-3596 luanne.harris@plygem.com						
Authorized Signature	Luanne Harris luanne.harris@plygem.com						
Technical Representative	Luanne Harris						
Address/Phone/Email	3948 Townsfair Way Suite 200 Columbus, OH 43219 (614) 532-3596 luanne.harris@simonton.com						
Quality Assurance Representative	AAMA						
Address/Phone/Email	1827 Walden Office Square Suite 550 Schaumburg, IL 60173 (847) 303-5664 webmaster@aamanet.org						
Category	Exterior Doors						
Subcategory	Sliding Exterior Door Assemblies						
Compliance Method	Certification Mark or Listing						
Certification Agency	American Architectural Manufacturers Association						
Validated By	American Architectural Manufacturers Association						
Referenced Standard and Year (of Standard)	<table border="0"> <thead> <tr> <th><u>Standard</u></th> <th><u>Year</u></th> </tr> </thead> <tbody> <tr> <td>AAMA 450</td> <td>2010</td> </tr> <tr> <td>AAMA/WDMA/CSA 101/I.S.2/A440</td> <td>2008</td> </tr> </tbody> </table>	<u>Standard</u>	<u>Year</u>	AAMA 450	2010	AAMA/WDMA/CSA 101/I.S.2/A440	2008
<u>Standard</u>	<u>Year</u>						
AAMA 450	2010						
AAMA/WDMA/CSA 101/I.S.2/A440	2008						
Equivalence of Product Standards Certified By	Florida Licensed Professional Engineer or Architect FL7612_R17_Equiv_EvalReport-IN0444-R7.pdf						

Date Submitted 11/15/2017
 Date Validated 12/05/2017
 Date Pending FBC Approval
 Date Approved 12/07/2017

Summary of Products

FL #	Model, Number or Name	Description
7612.1	06-05	ProFinish Contractor, ProFinish Master, PerfeXion Contractor 2-Lite Sliding Patio Door
		<p>Limits of Use Approved for use in HVHZ: No Approved for use outside HVHZ: Yes Impact Resistant: No Design Pressure: N/A Other: 77x84 (+/-30 PSF), 71x80 (+/-35 PSF), 71x96 (+/-35 PSF), 95x80 (+/-35 PSF), 71x80 (+/-50 PSF)</p> <p>Certification Agency Certificate FL7612 R17 C CAC 06-05 2P SGD (Fin) 71x80 R PG50.pdf FL7612 R17 C CAC 06-05 2P SGD (Fin) 71x80 R-PG35.pdf FL7612 R17 C CAC 06-05 2P SGD (Fin) 71x96 R PG35.pdf FL7612 R17 C CAC 06-05 2P SGD (Fin) 95x80 R35.pdf FL7612 R17 C CAC 06-05 2P SGD (Finless) 71x80 R PG35.pdf FL7612 R17 C CAC 06-05 2P SGD (Finless) 71x80 R PG50.pdf FL7612 R17 C CAC 06-05 2P SGD (Finless) 71x96 R PG35.pdf FL7612 R17 C CAC 06-05 2P SGD (Finless) 95x80 R35.pdf FL7612 R17 C CAC 06-05 2PSGD (Fin) 77x84 R-PG30.pdf</p> <p>Quality Assurance Contract Expiration Date 10/31/2021</p> <p>Installation Instructions FL7612 R17 II IN0340 06-05 2P PD 2X.pdf FL7612 R17 II IN0444-R7 06-05 2P 1X.pdf Verified By: American Architectural Manufacturers Association Created by Independent Third Party:</p> <p>Evaluation Reports FL7612 R17 AE EvalReport-IN0444-R7.pdf Created by Independent Third Party: Yes</p>
7612.2	06-05	ProFinish Contractor, ProFinish Master, PerfeXion Contractor Vinyl 3-Lite Sliding Patio Door
		<p>Limits of Use Approved for use in HVHZ: No Approved for use outside HVHZ: Yes Impact Resistant: No Design Pressure: N/A Other: 107x80 (+/-30 PSF), 107x80 (+/-45 PSF)</p> <p>Certification Agency Certificate FL7612 R17 C CAC 06-05 3P SGD (Fin) 107x80 R PG30.pdf FL7612 R17 C CAC 06-05 3P SGD (Fin) 107x80 R PG45.pdf</p> <p>Quality Assurance Contract Expiration Date 11/20/2022</p> <p>Installation Instructions FL7612 R17 II IN0341 06-05 3P PD 2X.pdf FL7612 R17 II IN0445-R4 06-05 3P PD 1X.pdf Verified By: American Architectural Manufacturers Association Created by Independent Third Party:</p> <p>Evaluation Reports FL7612 R17 AE EvalReport-IN0445-R4.pdf Created by Independent Third Party: Yes</p>
7612.3	06-05	Reflections 5300, 6100 VantagePointe Vinyl 2-Lite Sliding Patio Door with Transom (Retrofit Installation)
		<p>Limits of Use Approved for use in HVHZ: No Approved for use outside HVHZ: Yes Impact Resistant: No Design Pressure: +45/-45 Other: 71x116 Retrofit Installation</p> <p>Certification Agency Certificate FL7612 R17 C CAC 06-05 2P SGD w Transom (Finless) 71x116 R45.pdf</p> <p>Quality Assurance Contract Expiration Date 01/29/2022</p> <p>Installation Instructions FL7612 R17 II IN0413 06-05 2PD w Transom 2X.pdf Verified By: American Architectural Manufacturers Association Created by Independent Third Party:</p> <p>Evaluation Reports Created by Independent Third Party:</p>
7612.4	06-05	Reflections 5300, 6100 VantagePointe Vinyl 2-Lite Sliding Patio Door (Retrofit Installation)
		<p>Limits of Use Approved for use in HVHZ: No Approved for use outside HVHZ: Yes</p> <p>Certification Agency Certificate FL7612 R17 C CAC 06-05 2P SGD (Finless) 71x80 R PG35.pdf</p>

<p>Impact Resistant: No Design Pressure: N/A Other: 95x80 (+/-35 PSF), 71x96 (+/-35 PSF), 71x80 (+/-35 PSF), 71x80 (+/-50 PSF) Retrofit Installation</p>		<p>FL7612_R17_C_CAC_06-05_2P_SGD_(Finless)_71x80_R_PG50.pdf FL7612_R17_C_CAC_06-05_2P_SGD_(Finless)_71x96_R_PG35.pdf FL7612_R17_C_CAC_06-05_2P_SGD_(Finless)_95x80_R35.pdf Quality Assurance Contract Expiration Date 01/29/2022 Installation Instructions FL7612_R17_II_IN0412_06-05_2P_PD_2X.pdf Verified By: American Architectural Manufacturers Association Created by Independent Third Party: Evaluation Reports Created by Independent Third Party:</p>
7612.5	15-15	Inovo, 6500 VantagePointe 2-Lite Sliding Patio Door (Retrofit Installation)
<p>Limits of Use Approved for use in HVHZ: No Approved for use outside HVHZ: Yes Impact Resistant: No Design Pressure: N/A Other: 71x81 (+/-35), 71x81 (+/-50 PSF), 95x95 (+/-35) Retrofit Installation</p>		<p>Certification Agency Certificate FL7612_R17_C_CAC_15-15_2P_SGD_71x81_R-PG35_(Finless).pdf FL7612_R17_C_CAC_15-15_2P_SGD_71x81_R-PG50_(Finless).pdf FL7612_R17_C_CAC_15-15_2P_SGD_95x95_R_PG35_(finless).pdf Quality Assurance Contract Expiration Date 09/14/2020 Installation Instructions FL7612_R17_II_IN0573-R2_15-15_2P_PD.pdf Verified By: American Architectural Manufacturers Association Created by Independent Third Party: Evaluation Reports FL7612_R17_AE_EvalReport-IN0573-R2.pdf Created by Independent Third Party: Yes</p>
7612.6	15-15	Inovo, VantagePointe 6500 3-Lite Sliding Patio Door (Retrofit Installation)
<p>Limits of Use Approved for use in HVHZ: No Approved for use outside HVHZ: Yes Impact Resistant: No Design Pressure: +35/-35 Other: 107x79</p>		<p>Certification Agency Certificate FL7612_R17_C_CAC_15-15_3P_SGD_107x79_R-PG35_(Finless).pdf Quality Assurance Contract Expiration Date 09/14/2020 Installation Instructions FL7612_R17_II_IN0581-R1_15-15_3P_PD.pdf Verified By: American Architectural Manufacturers Association Created by Independent Third Party: Evaluation Reports FL7612_R17_AE_EvalReport-IN0581-R1.pdf Created by Independent Third Party: Yes</p>
7612.7	15-15	Inovo, VantagePointe 6500 4-Lite Sliding Patio Door (Retrofit Installation)
<p>Limits of Use Approved for use in HVHZ: No Approved for use outside HVHZ: Yes Impact Resistant: No Design Pressure: +25/-25 Other: 143x79</p>		<p>Certification Agency Certificate FL7612_R17_C_CAC_15-15_4P_SGD_143x79_R_PG25_(finless).pdf Quality Assurance Contract Expiration Date 07/16/2020 Installation Instructions FL7612_R17_II_IN0583-R1_15-15_4P_PD.pdf Verified By: American Architectural Manufacturers Association Created by Independent Third Party: Evaluation Reports FL7612_R17_AE_EvalReport-IN0583-R1.pdf Created by Independent Third Party: Yes</p>
7612.8	15-16	Inovo, 6500 VantagePointe 2-Lite Sliding Patio Door
<p>Limits of Use Approved for use in HVHZ: No Approved for use outside HVHZ: Yes Impact Resistant: No Design Pressure: N/A Other: 71x81 (+/-20 PSF), 71x81 (+/-35 PSF), 71x81 (+/-50 PSF), 95x79 (+/-35), 95x95 (+/-35)</p>		<p>Certification Agency Certificate FL7612_R17_C_CAC_15-16_2P_SGD_71x81_R_PG20_(NO_WEEN_HOLES).pdf FL7612_R17_C_CAC_15-16_2P_SGD_71x81_R_PG35.pdf FL7612_R17_C_CAC_15-16_2P_SGD_71x81_R-PG50.pdf FL7612_R17_C_CAC_15-16_2P_SGD_95x79_R_PG35.pdf FL7612_R17_C_CAC_15-16_2P_SGD_95x95_R_PG35.pdf Quality Assurance Contract Expiration Date 06/04/2020 Installation Instructions FL7612_R17_II_IN0571_15-16_2P_PD_2X.pdf Verified By: American Architectural Manufacturers</p>

		Association Created by Independent Third Party: Evaluation Reports Created by Independent Third Party:
7612.9	15-16	Inovo, 6500 VantagePointe 3-Lite Sliding Patio Door
Limits of Use Approved for use in HVHZ: No Approved for use outside HVHZ: Yes Impact Resistant: No Design Pressure: +35/-35 Other: 107x79		Certification Agency Certificate FL7612_R17_C_CAC_15-16_3P_SGD_107x79_R_PG35.pdf Quality Assurance Contract Expiration Date 06/03/2020 Installation Instructions FL7612_R17_II_IN0576_15-16_3P_PD_2X.pdf Verified By: American Architectural Manufacturers Association Created by Independent Third Party: Evaluation Reports Created by Independent Third Party:

[Back](#) [Next](#)

Contact Us :: [2601 Blair Stone Road, Tallahassee FL 32399](#) Phone: 850-487-1824

The State of Florida is an AA/EEO employer. [Copyright 2007-2013 State of Florida.](#) :: [Privacy Statement](#) :: [Accessibility Statement](#) :: [Refund Statement](#)

Under Florida law, email addresses are public records. If you do not want your e-mail address released in response to a public-records request, do not send electronic mail to this entity. Instead, contact the office by phone or by traditional mail. If you have any questions, please contact 850.487.1395. *Pursuant to Section 455.275(1), Florida Statutes, effective October 1, 2012, licensees licensed under Chapter 455, F.S. must provide the Department with an email address if they have one. The email provided may be used for official communication with the licensee. However email addresses are public record. If you do not wish to supply a personal address, please provide the Department with an email address which can be made available to the public. To determine if you are a licensee under Chapter 455, F.S., please click [here](#).

Product Approval Accepts:



Credit Card
Safe



MODEL DESIGNATION: Simonton Series 06-05 2-Panel Vinyl Patio Door
MAXIMUM OVERALL NOMINAL SIZE: See Size Chart
DESIGN PRESSURE RATING: See Size Chart
USABLE CONFIGURATIONS: XO, OX
GENERAL DESCRIPTION: The head, sill, and side jambs are extruded PVC. The wall thickness through which the anchor screw penetrates is a minimum of 0.070".

NO P.E. SEAL REQUIRED
 INSTALLATION SUPPORTED
 BY AAMA TEST REPORTS

REV. #:	REVISIONS:	REVISED BY:	DATE:
2	UPDATED NOTES, GENERAL DESCRIPTION, AND ANCHOR LOCATIONS PER NEW TESTING.	T.D.D.	04/06/11
3	ADDED SIZES PER NEW TESTING.	T.D.D.	05/04/11
4	ADDED GLAZING DETAILS.	T.D.D.	06/20/11
5	ADDED GLAZING NOTE AND UPDATED SIZE CHART PER NEW TESTING.	T.D.D.	03/11/13
6	ADDED MIN. EDGE DIST. NOTE	B.J.S.	06/17/15
7	UPDATED SIZE CHART & ANCHOR SPACING	LMH	11/23/15

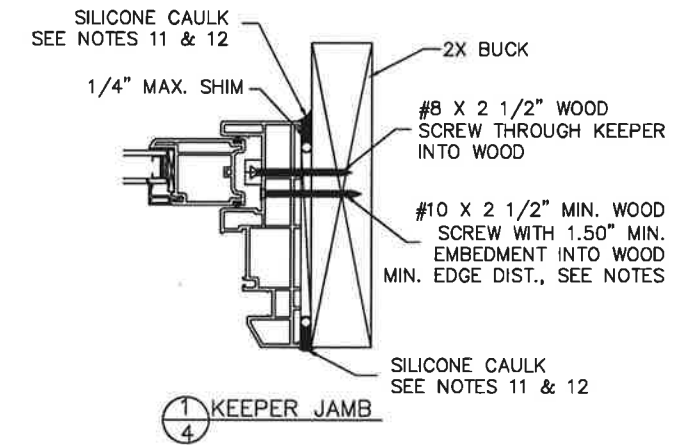
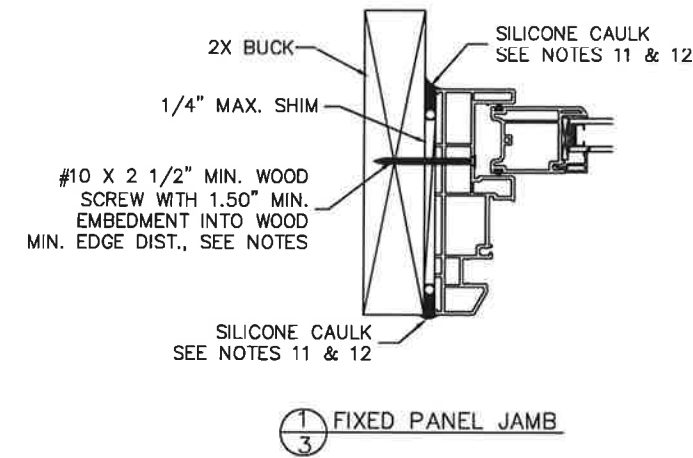
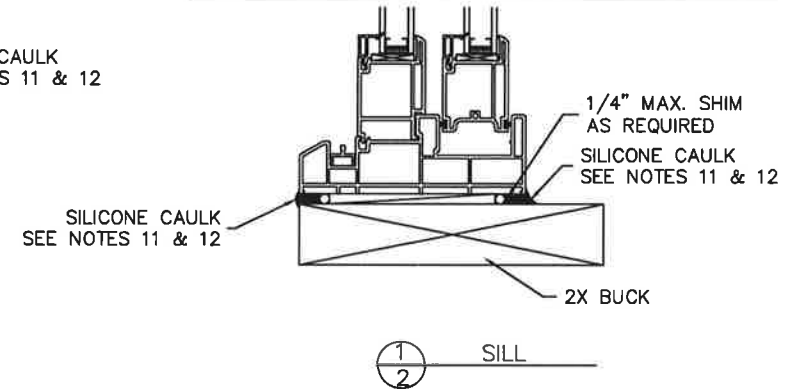
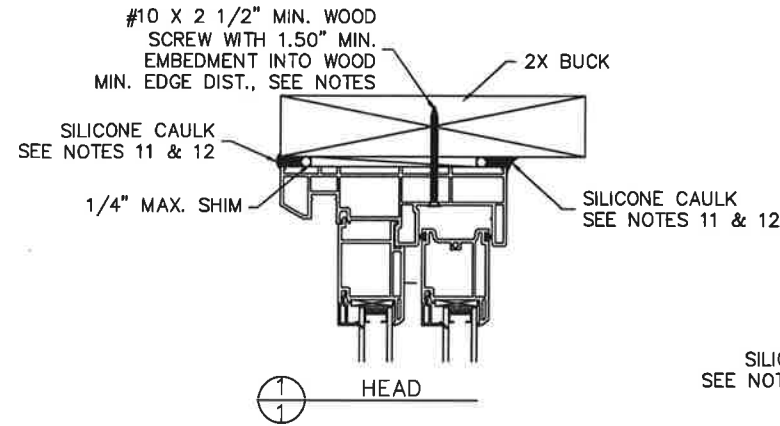
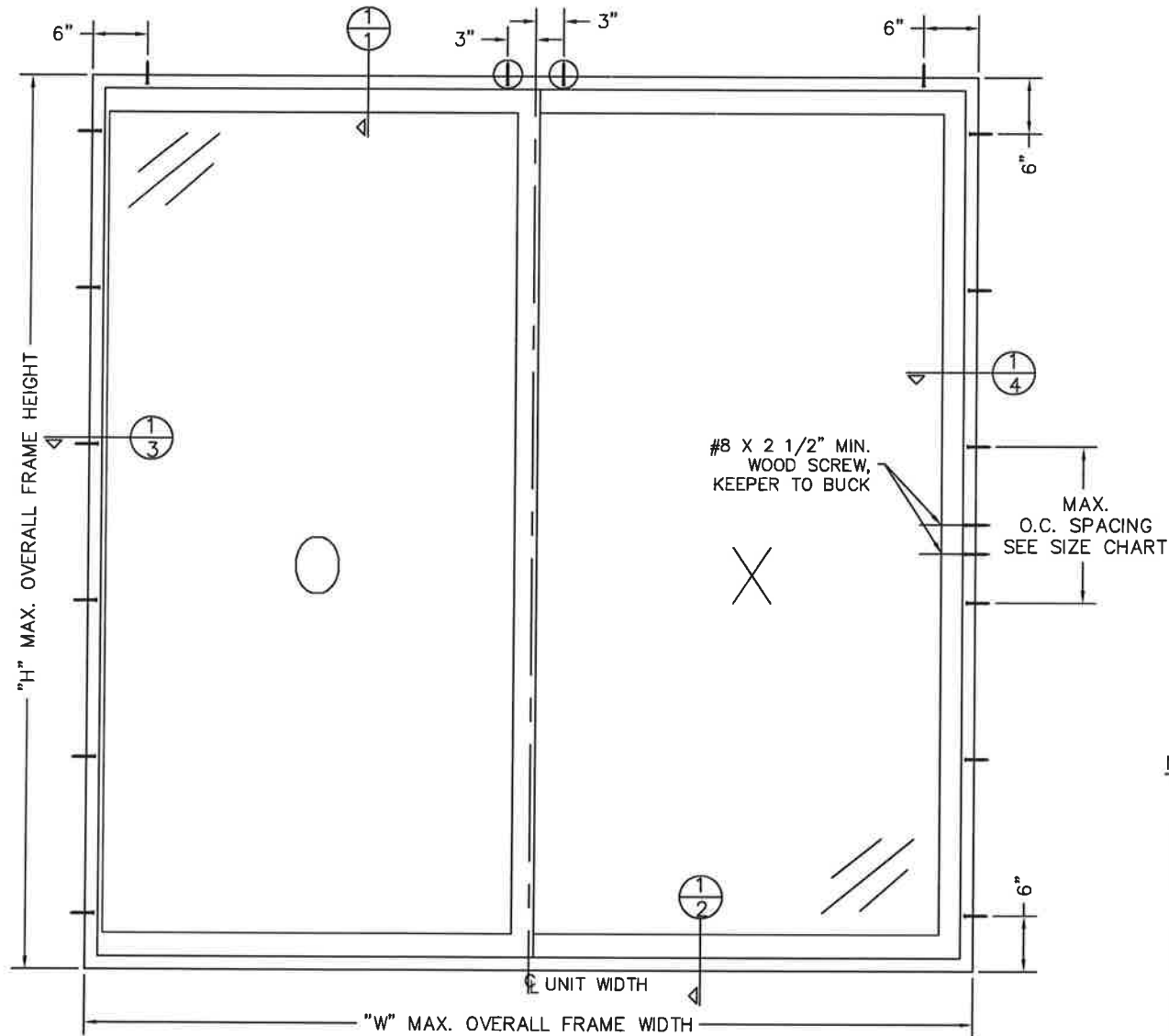

NOTES:

1. This installation has been evaluated for use in locations adhering to the Texas & Florida Building Codes and where pressure requirements as determined by ASCE 7 Minimum Design Loads for Buildings and Other Structures do not exceed the design pressure ratings herein, for use outside the H.V.H.Z.
2. All exterior perimeter surfaces of the door must be caulked. Interior caulking is optional unless noted otherwise.
3. Anchors shall be specified and spaced as shown. Anchor embedment to base material shall be beyond wall dressing or stucco and into wood.
4. The responsibility for selection of Simonton products to meet any applicable local laws, building codes, ordinances, or other safety requirements rests solely with the architect, building owner, or contractor.
5. Shims are optional. Maximum shim stack is 1/4".
6. Wood bucks (by others) must be engineered and anchored properly to transfer loads to the structure.
7. When used in areas requiring impact protection, this product **REQUIRES** the use of approved impact resistant shutters or other external protection.
8. Flashing should be applied using the ASTM E 2112 method appropriate for the opening into which the door is being installed.
9. Installation anchors should be at least 3/4" from the edge of the wood.
10. Glazing shall comply with ASTM E 1300 and safety glazing requirements per Florida Building Code section 2406.
11. Use 100% pure silicon caulk. Make sure surfaces are completely free from all old caulk, damaged wood, wood fibers, grease, oil dirt, rust, mold or similar contaminants. Vacuum opening surfaces completely. A fully primed surface is recommended, but not required. Cleaning of all surfaces should be done the same day of which the silicone caulk is to be applied. For more details see "New Construction Installation Instructions" on Simonton.com.
12. Caulk application: recommended air and surface temperatures at the time of application are to be between 40 and 90 degrees F. Insure all contact surfaces are clean and dry including the new window(s). Use a backer rod on all joints >3/4" deep and/or wider than 1/4". Finished caulk joint should be a minimum of 3/8" deep and make full contact with both the new window and structural opening surfaces. Silicone caulk should be forced into joint or compressed to assure full contact on both surfaces and to expel any air pockets.

SIZE CHART			
OVERALL SIZE		O.C. SPACING	DP RATING
WIDTH "W"	HEIGHT "H"		
71"	96"	17"	±35 PSF
95"	80"	23"	
71"	80"	23"	±50 PSF
71"	80"	23"	

① CIRCLED ANCHORS REQUIRED ONLY FOR 95x80 AND 71x80-DP35.

DISCLOSURE STATEMENT		MATERIAL:		Dimensional Tolerances Unless Otherwise Specified		SIMONTON® WINDOWS	
This document is the property of Simonton Windows, which retains all proprietary and other rights to its subject matter. This document is provided to the recipient on the expressed condition that it is not to be disclosed, reproduced in whole or part, nor used in conjunction with the design, manufacture or repair of goods for anyone other than Simonton Windows without its consent. This restriction does not limit the recipient's rights to utilize information contained in this document which is properly obtained from another source.		RMS FINISH:		Decimals		SIZE: DRAWING NO.: REV.:	
		EXCEPT AS NOTED		Angles		B INO412 7	
		ALLOY & TEMPER:		.X ± .03		DRAWN BY: DATE:	
		WEIGHT:		.XX ± .01		T.D.D. 04/10/09	
		SURFACE AREA:		.XXX ± .005		CHECKED BY: DATE:	
FINISH TREATMENT:				SCALE: FIT SHEET: 1 of 1		APPR'VD BY: DATE:	
FILE: INO412				SERIES: 06-05 2-PANEL PATIO DOOR		TITLE: 2X BUCK RETROFIT INSTALLATION (AS TESTED)	



Home Depot Contractor License Numbers:

FL: EC0001440, CGC1514813, CRC046858, CAC1813/67, CFC1426021, CFC1427642, 22640, CAC 1818831, CCC1331113, CCC1331130

Salesperson Name and Registration Number:

Daniel Maloney :

Home Improvement Agreement

Home Depot U.S.A., Inc. ("Home Depot") or Service Provider named below will furnish, install and/or service the equipment listed below at the price, terms and conditions as outlined on this form.

Customer Information:

DAVID ROMANO		Tampa	1-5SP2HPF 10725693	
First Name	Last Name	Branch Name	Lead #	
5256 Jada Circle Belle Isle FL 32812		ORLANDO	FL	32812
Customer Address		City	State	Zip
Home Phone#	(321) 278-1257	Work Phone#	Cell Phone#	
romandj5256@gmail.com				
Customer E-mail Address				

NOTICE OF RIGHT TO CANCEL: YOU MAY CANCEL THIS AGREEMENT WITHOUT PENALTY OR OBLIGATION BY DELIVERING WRITTEN NOTICE TO HOME DEPOT AT:

9208 Florida Palm Drive Tampa FL 33619

Address City State Zip
or Email customercancellationsouth@homedepot.com

BY MIDNIGHT ON THE THIRD BUSINESS DAY AFTER SIGNING, UNLESS THE STATE SUPPLEMENT PROVIDES A different CANCELLATION PERIOD. THE STATE SUPPLEMENT CONTAINS A FORM TO USE IF ONE IS SPECIFICALLY PRESCRIBED BY LAW IN YOUR STATE. YOUR PAYMENT(S) WILL BE RETURNED WITHIN TEN (10) BUSINESS DAYS AFTER HOME DEPOT'S RECEIPT OF YOUR NOTICE. YOU MUST MAKE AVAILABLE FOR PICKUP BY HOME DEPOT OR PROFESSIONAL, AT YOUR SERVICE ADDRESS, AND IN SUBSTANTIALLY THE SAME CONDITION AS WHEN DELIVERED, ANY MERCHANDISE OR MATERIALS DELIVERED TO YOU. OR YOU MAY CONTACT HOME DEPOT FOR INSTRUCTIONS REGARDING RETURN SHIPMENT AT HOME DEPOT'S EXPENSE.

THE LAW REQUIRES THAT THE CONTRACTOR GIVE YOU A NOTICE EXPLAINING YOUR RIGHT TO CANCEL. PLEASE SIGN BELOW TO ACKNOWLEDGE THAT YOU HAVE BEEN GIVEN ORAL AND WRITTEN NOTICE OF YOUR RIGHT TO CANCEL.

Acknowledged by:

X 
Customer's Signature

03/20/2018

Date

Contract Price and Payment Schedule: Payment of the Contract Price is due upon completion unless a different payment schedule is specified in the State Supplement.

Contract Price	\$ 4197.60	Includes all applicable discounts, rebates, and , taxes. Excludes finance charges.*
Minimum ²⁵ % deposit	\$ 1049.00	Due Immediately
Remaining balance	\$ 3148.60	Due upon completion

Finance Charges

*Any interest payments or other finance charges will be determined by Customer's separate cardholder or loan agreement, to which The Home Depot is NOT a party, and will be in addition to Customer's payment under this Agreement. Customer is subject to the terms and conditions of the cardholder or loan agreement, as applicable. No funds should be made payable to Service Provider; however, Service Provider may collect Customer's payment(s) made payable to The Home Depot.

Insurance proceeds will will not be used to pay some or all of the total amount of sale.

Description of Work to be Performed:

Installation of Windows

A more detailed description of the work to be performed is included in the section entitled Scope of Work which appears on page 3 of this Agreement.

Anticipated Delivery Date / Installation Schedule

Approximate Start Date: 05/15/2018

Approximate Finish Date: 06/12/2018



All dates are approximate and subject to change based on unforeseen events including inclement weather, permitting delays, and delays in confirming insurance coverage of Your claim for any repair, if applicable.

Electronic Records Authorization: You are entitled to a paper copy of this Agreement if you choose. If you consent to an e-mailed copy, your consent applies to this Agreement and all subsequent documents and written communications related to this agreement. By contacting your Service Provider, you may update your email address, withdraw your consent, or obtain a paper copy of the Agreement or related documents at no charge. By providing your consent and verifying your email address above, you confirm that you have access to a computer that can receive and open emails and PDF documents.

By initialing this paragraph, I consent to receive only electronic records related to this transaction.

m Initial

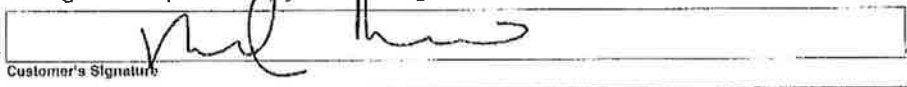
Acceptance and Authorization: By signing below, you authorize Home Depot to (a) arrange for Service Provider to perform Installation and/or (b) order and arrange for the delivery of special order merchandise, including special order merchandise that may be custom made, as specified in this Agreement. Do not sign if blank or incomplete. (Service Provider's/permitting information may need to be provided to You later.) By signing, you acknowledge that you have read, understand, and accept this Agreement in its entirety, including the General Terms and Conditions and State Supplement, if any. You further acknowledge receiving a complete copy of this Agreement. Keep it to protect your legal rights.

X		03/20/2018
	Customer's Signature	Date
X		
	Co-Signer (if applicable)	Date
X		03/20/2018
	Sales Consultant's Signature	Date

License number(s) held by or on behalf of the Home Depot:

License numbers are subject to change in accordance with local or state government processes. For the most current listing of license numbers held by or on behalf of the Home Depot, please visit www.homedepot.com/licensesnumbers.

Scope of Work

Job #: (Internal Reference)	Products:	Spec Sheet(s) #:	Project Amount	
1-5SP21HPF	Roofing Siding ✓ Windows Gutters / Covers Entry Doors	Insulation	1-5SP2HPF	\$4197.60
	Roofing Siding Gutters / Covers	Windows Entry Doors		\$
	Roofing Siding Gutters / Covers	Windows Entry Doors		\$
	Roofing Siding Gutters / Covers	Windows Entry Doors		\$
			SubTotal	\$4197.60
			Sales Tax	\$0.00
			Total Contract Amount	\$4197.60

Warranty:

The warranty on the work identified above is listed in the General Terms and Conditions, or if applicable, specified in the following documents:

Warranty Name(s):	VantagePointe 6500-6100-6060 Warranty
-------------------	---------------------------------------



ADDITIONAL REMARKS SCHEDULE

AGENCY MARSH USA, INC.		NAMED INSURED THE HOME DEPOT, INC. HOME DEPOT U.S.A., INC. 2455 PACES FERRY ROAD BUILDING C-20 ATLANTA, GA 30339	
POLICY NUMBER		EFFECTIVE DATE:	
CARRIER	NAIC CODE		

ADDITIONAL REMARKS

THIS ADDITIONAL REMARKS FORM IS A SCHEDULE TO ACORD FORM.
FORM NUMBER: 25 **FORM TITLE:** Certificate of Liability Insurance

RAQUEL G. SWANNER - CGC1514813 and CCC1331113
 JEFF MASTERSON - EC9001440
 RICHARD W. MOORE JR. - CAC1813797 and CFC1429021
 BOYSIE RAMDIAL - CRC048858
 BROOK MYERS - CAC1818831

WORKERS COMPENSATION IS COVERED IN THE STATE OF FLORIDA

**** HOME DEPOT INSURED ****

- The Home Depot, Inc.
- The Home Depot U.S.A., Inc.
- Home Depot USA, Inc. dba The Home Depot
- Home Depot USA, Inc. dba Your Other Warehouse, LLC
- Home Depot of Puerto Rico, Inc
- Home Depot Product Authority, LLC
- Home Depot Store Support, Inc.
- Rec Beacon, LLC
- Interline Brands, Inc.
- Interline Brands, Inc. dba:
- Barnett
- Copperfield
- Eagle Maintenance Supply
- Hardware Express
- Leran
- Maintenance USA
- Renovations Plus
- Supplyworks
- US Lock
- Wimmar
- CleanSource
- JanPak
- AmSan
- Sexaor
- Trayco
- Zip Technologies

1-SSP2-HPF - Romano

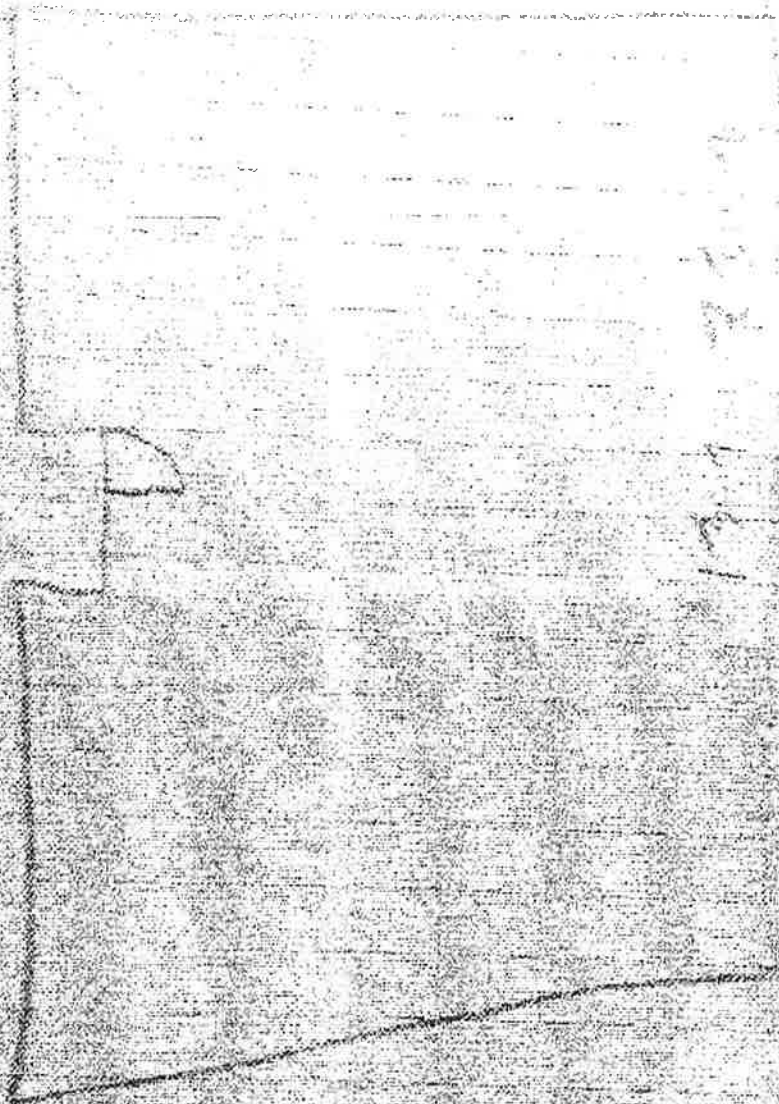

OF
RV

1-SSP2-HPF - Romano

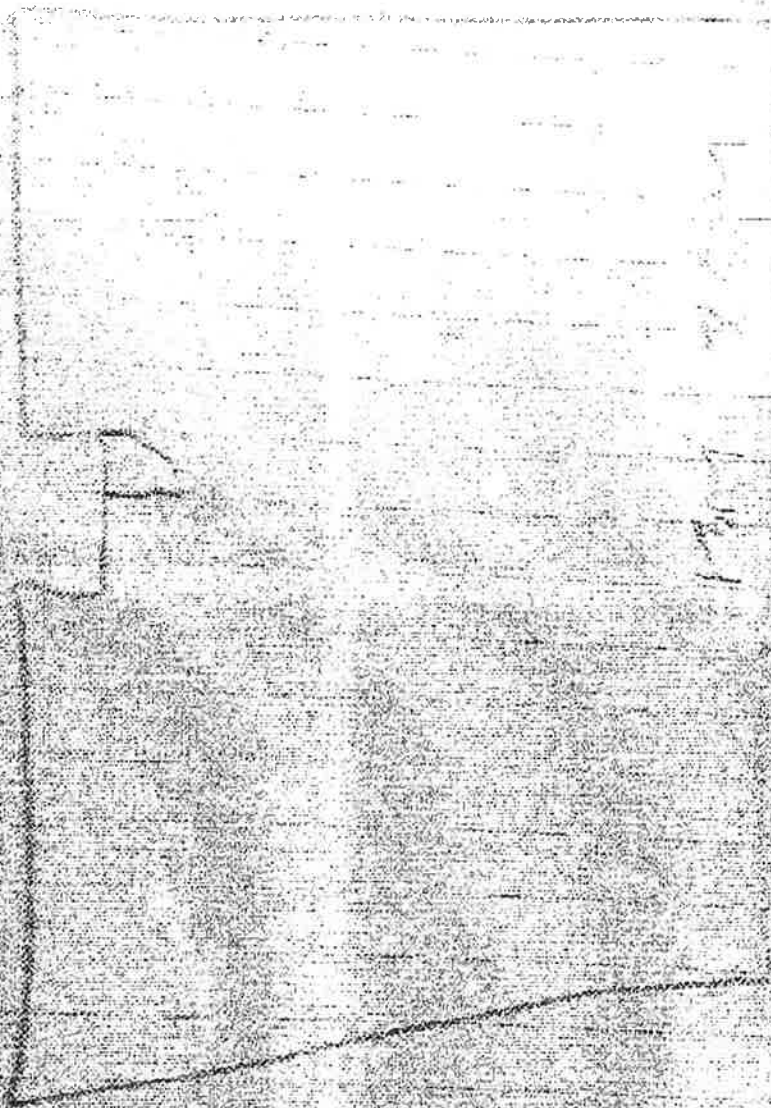

RV
RV



**STATE OF FLORIDA
DEPARTMENT OF BUSINESS AND PROFESSIONAL REGULATION**

**CONSTRUCTION INDUSTRY LICENSING BOARD
2601 BLAIR STONE ROAD
TALLAHASSEE FL 32399-0783**

(850) 487-1395

**RAMDIAL, BOYSIE GANGA
THE HOME DEPOT
2455 PACES FERRY RD, HSC C-11
ATLANTA GA 30339**

Congratulations! With this license you become one of the nearly one million Floridians licensed by the Department of Business and Professional Regulation. Our professionals and businesses range from architects to yacht brokers, from boxers to barbecue restaurants, and they keep Florida's economy strong.

Every day we work to improve the way we do business in order to serve you better. For information about our services, please go onto www.myfloridalicense.com. There you can find more information about our divisions and the regulations that impact you, subscribe to department newsletters and learn more about the Department's initiatives.

Our mission at the Department is: License Efficiently, Regulate Fairly. We constantly strive to serve you better so that you can serve your customers. Thank you for doing business in Florida, and congratulations on your new license!



**STATE OF FLORIDA
DEPARTMENT OF BUSINESS AND
PROFESSIONAL REGULATION**

CRC046858

ISSUED: 03/13/2017

**CERTIFIED RESIDENTIAL CONTRACTOR
RAMDIAL, BOYSIE GANGA
THE HOME DEPOT**

**IS CERTIFIED under the provisions of Ch. 489 FS.
Expiration date : AUG 31, 2018 L1703130001202**

DETACH HERE

RICK SCOTT, GOVERNOR

MATILDE MILLER, INTERIM SECRETARY

**STATE OF FLORIDA
DEPARTMENT OF BUSINESS AND PROFESSIONAL REGULATION
CONSTRUCTION INDUSTRY LICENSING BOARD**

LICENSE NUMBER

CRC046858

**The RESIDENTIAL CONTRACTOR
Named below IS CERTIFIED
Under the provisions of Chapter 489 FS.
Expiration date: AUG 31, 2018**

**RAMDIAL, BOYSIE GANGA
THE HOME DEPOT
2455 PACES FERRY RD, HSC C-11
ATLANTA GA 30339**



RECEIVED
FEB 24 2018

2017 - 2018 HILLSBOROUGH COUNTY BUSINESS TAX RECEIPT
OCC. CODE 090.022000 RESIDENTIAL CONTRACTOR

EXPIRES SEPTEMBER 30, 2018

ACCOUNT NO.
35611
RENEWAL

1 Employees	Receipt Fee	16.00
	Hazardous Waste Surcharge	40.00
	Law Library Fee	0.00

ORC048858

BUSINESS RAMDIAL BOYSIE GANGA
THE HOME DEPOT
8208 FLORIDA PALM DR
TAMPA, FL 33619

2017 - 2018

NAME BOYSIE RAMDIAL
MAILING C/O: THE HOME DEPOT USA INC
ADDRESS THE HOME DEPOT
2455 PACES FERRY RD

Paid 16-830-016173
07/24/2017 58.00

BUSINESS TAX RECEIPT

ISSUE HEREBY IMPOSES A PAYABLE TAX TO ENSURE
IT IS RECEIVED, PHOTOGRAPHIC OR OCCUPATIONAL SPECIFIED HEREON

DOUG BELDEN, TAX COLLECTOR
813-636-8200
THIS BECOMES A TAX RECEIPT WHEN VALIDATED.



- [Searches](#)
- [Sales Search](#)
- [Results](#)
- [Property Record Card](#)
- [My Favorites](#)

[Sign up for e-Notify...](#)

5256 Jade Cir < 20-23-30-4395-00-320 >

Name(s)
 Romano David J
Physical Street Address
 5256 Jade Cir
Mailing Address On File
 5256 Jade Cir
 Belle Isle, FL 32812-2101
Incorrect Mailing Address?
Physical Street Address
 5256 Jade Cir
Postal City and Zipcode
 Orlando, FL 32812
Property Use
 0103 - Single Fam Class III
Municipality
 Belle Isle

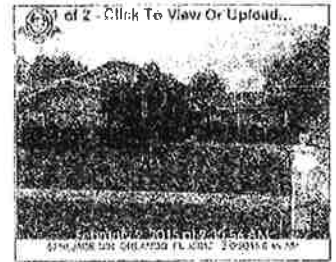

View 2017 Property Record Card

- [Property Features](#)
- [Values, Exemptions and Taxes](#)
- [Sales Analysis](#)
- [Location Info](#)
- [Market Stats](#)
- [Update Information](#)

2018 values will be available in August of 2018.

Property Description

LAKE CONWAY SHORES 7/50 LOT 32

[View Plat](#)

Total Land Area 13,237 sqft (+/-) | 0.30 acres (+/-) GIS Calculated Notice

Show parcel on old map.

Land

Land Use Code	Zoning	Land Units	Unit Price	Land Value	Class Unit Price	Class Value
0100 - Single Family	R-1-AA	1 LOT(S)	working...	working...	working...	working...

Page 1 of 1 (1 total records)

Buildings

Important Information		Structure			
	Model Code: 01 - Single Fam Residence	Actual Year Built: 1978	Gross Area: 3873 sqft		
	Type Code: 0103 - Single Fam Class III	Beds: 3	Living Area: 2553 sqft		
	Building Value: working...	Baths: 3.0	Exterior Wall: Board & Batten Above Average		
	Estimated New Cost: working...	Floors: 2	Interior Wall: Drywall		

Page 1 of 1 (1 total records)

Extra Features

Description	Date Built	Units	XFOB Value
FPL2 - Average Fireplace	01/01/1978	1 Unit(s)	working...
PL2 - Above Average Pool	01/01/1983	1 Unit(s)	working...
SCR2 - Sem Enc 2	01/01/1983	1 Unit(s)	working...
P1NV - Patio No Value	01/01/2010	2 Unit(s)	working...

Page 1 of 1 (4 total records)

This Data Printed on 03/26/2018 and System Data Last Refreshed on 03/25/2018