



**City of Belle Isle Job Site Card Window/Door PERMIT 2018-04-061**

**PERMIT MUST BE POSTED ON SITE** - A permit expires in 6 months if approved inspections are not recorded /schedule within that time frame. **You are responsible for scheduling and keeping track of all inspections.**

Permit Number: 2018-04-061

Site Address: 5008 Darden Ave. 32812

Subdivision:

Description of Work: Size for Size 7 Windows and 2 Doors

Issue Date: 4/24/2018

Parcel Number: 17-23-30-4385-03-290

Class: Residential

Issued To: THE HOME DEPOT

Name: RAMDIAL, BOYSIE GANGA

Business Phone: 407 469-5599

Contractor License #: CRC046858

Payment Date & Method: 4 / 24 / 2018

Visa    Master Card    Amex    Discover    Check / Money Order # 6176

**Schedule Inspections via Email at: [BDscheduling@universalengineering.com](mailto:BDscheduling@universalengineering.com)**

**SCHEDULE INSPECTIONS BY 4PM CUT OFF TIME**

**Inspection Results Will Be Sent Out the Following Business Day**

**"WARNING TO OWNER: YOUR FAILURE TO RECORD A NOTICE OF COMMENCEMENT MAY RESULT IN YOUR PAYING TWICE FOR IMPROVEMENTS TO YOUR PROPERTY. IF YOU INTEND TO OBTAIN FINANCING, CONSULT WITH YOUR LENDER OR AN ATTORNEY BEFORE RECORDING YOUR NOTICE OF COMMENCEMENT."**

BUILDING	INSPECTOR	DATE	COMMENTS
900 In Progress			
910 Final			

Inspection requests are to be emailed to [BDscheduling@UniversalEngineering.com](mailto:BDscheduling@UniversalEngineering.com); a confirmation email will be sent back to you upon scheduling. **Next-Day Inspection requests must be made by 4pm.** Please include the following in your request: Permit #, project address, type of inspection, date of the requested inspection, a contact name & a contact phone number. AM or PM may be requested but cannot be guaranteed. Inspection results will be sent out the following business day. A permit expires in 6 months if approved inspections are not recorded /scheduled within that time frame. **You are responsible for scheduling and keeping track of all your inspections** –



# City of Belle Isle

Universal Engineering Sciences 3532 Maggie Blvd., Orlando, FL 32814  
Tel 407-581-8161 \* Fax 407-581-0313 \* [www.universalengineering.com](http://www.universalengineering.com)



## APPLICATION FOR SIZE-FOR-SIZE WINDOW / DOOR PERMIT

**WARNING TO OWNER:** YOUR FAILURE TO RECORD A NOTICE OF COMMENCEMENT MAY RESULT IN YOUR PAYING TWICE FOR IMPROVEMENTS TO YOUR PROPERTY. A NOTICE OF COMMENCEMENT MUST BE RECORDED AND POSTED ON THE JOB SITE BEFORE THE FIRST INSPECTION. IF YOU INTEND TO OBTAIN FINANCING, CONSULT WITH YOUR LENDER OR AN ATTORNEY BEFORE RECORDING YOUR NOTICE OF COMMENCEMENT.

DATE OF APPLICATION: 4/23/18 PERMIT NUMBER 2018-04-061

PLEASE PRINT. The undersigned hereby applies for a permit to make installations as indicated below:

Project Address 5008 Darden Ave., Belle Isle, FL 32809 <sup>X</sup> 32812  
Property Owner Michele Garey Phone 330-907-6370  
Property Owner's Mailing Address 5008 Darden Ave. City Belle Isle  
State FL Zip Code 32812 Parcel Id Number: 17-23-30-4385-03-280  
REQUIRED! To obtain this information, please visit <http://www.ocpafl.org/Searches/ParcelSearch.aspx>

Type of Building: Residential  Commercial  Other

**REQUIRED! Florida Product Approval Form - NOTE: Installation instructions must be posted on-site before your first inspection!!**

Please indicate the nature of work by completing the information below:

Number of Size-for-Size Windows: 7 Number of Size-for-Size Doors: 2 Job Valuation: \$10,462

I hereby certify that the above is true and correct to the best of my knowledge and make Application for Permit as outlined above, and if same is granted I agree to conform to all Florida Building Code Regulations and City Ordinances regulating same and in accordance with plans submitted. The issuance of this permit does not grant permission to violate any applicable Town and/or State of Florida codes and/or ordinances. By signing below, I recognize Republic Services is by legal contract the sole authorized provider of garbage, recycling, yard waste, and commercial garbage and construction debris collection and disposal services with the city limits of the City. Contractors, homeowners and commercial businesses may contact Republic Services at 407-293-8000 to setup accounts for Commercial, Construction Roll Off, or other services needed. Rates are fixed by contract and are available at City Hall or from Republic Services. The City enforces the contract through its code enforcement office. Failure to comply will result in a stop work order.

BY SIGNING THIS APPLICATION, YOU ARE CERTIFYING THAT YOU ARE ACTING AS THE OWNER'S AGENT FOR THIS PERMIT:

LICENSE HOLDER SIGNATURE [Signature] LICENSE # 0220046858  
LICENSE HOLDER NAME Boysie RAMDIAL COMPANY NAME THE Home Depot  
Street Address 9208 FLORIDA PALM DRIVE  
City TAMPA State FL Zip Code 33619 Phone Number 407-469-5599  
Email Address \_\_\_\_\_

Building Official: SM Date 4-24-17  
Verified Contractor's Licenses & Insurance are on file [Signature] Date 4-24-17

Zoning Fee	\$	<u>0</u>
Permit Fee	\$	<u>65</u>
Review Fee	\$	<u>32.50</u>
1% BCAIB Fee	\$	<u>2. min</u>
1.5% DCA Fee	\$	<u>2. min</u>
Total Permit Fee	\$	<u>101.50</u>

need LTR  Rec'd NOC  BT IK 4x10 25 42 65-2 32.50 = 97.50

**PAID**  
4-24-2018  
015A 6176

DOC # 20180239141  
04/23/2018 09:52 AM Page 1 of 1  
Rec Fee: \$10.00  
Deed Doc Tax: \$0.00  
Mortgage Doc Tax: \$0.00  
Intangible Tax: \$0.00  
Phil Diamond, Comptroller  
Orange County, FL  
Ret To: SIMPLIFILE LC

THIS INSTRUMENT PREPARED BY:  
Name: The Home Depot  
Address: 9208 Florida Palm Dr  
Tampa, FL 33619

## NOTICE OF COMMENCEMENT

Permit Number: \_\_\_\_\_  
Parcel ID Number: 17-25-30-4385-03-280

The undersigned hereby gives notice that improvement will be made to certain real property, and in accordance with Chapter 713, Florida Statutes, the following information is provided in this Notice of Commencement.

- DESCRIPTION OF PROPERTY: (Legal description of the property and street address if available)  
Lake Conway Estates Section Six Lot 308  
3008 Darden Ave. Orlando, FL 32812
- GENERAL DESCRIPTION OF IMPROVEMENT:  
Replace windows and doors
- OWNER INFORMATION OR LESSEE INFORMATION IF THE LESSEE CONTRACTED FOR THE IMPROVEMENT:  
Name and address: Michele Garey 3008 Darden Ave. Orlando, FL 32812  
Interest in property: owner  
Fee Simple Title Holder (If other than owner listed above) Name: \_\_\_\_\_  
Address: \_\_\_\_\_
- CONTRACTOR: Name: The Home Depot Phone Number: 813-626-7648  
Address: 9208 Florida Palm Dr Tampa FL 33619
- SURETY (If applicable, a copy of the payment bond is attached): Name: \_\_\_\_\_  
Address: \_\_\_\_\_ Amount of Bond: \_\_\_\_\_
- LENDER: Name: \_\_\_\_\_ Phone Number: \_\_\_\_\_  
Address: \_\_\_\_\_
- Persons within the State of Florida Designated by Owner upon whom notices or other documents may be served as provided by Section 713.13(1)(a)?, Florida Statutes.  
Name: \_\_\_\_\_ Phone Number: \_\_\_\_\_  
Address: \_\_\_\_\_
- In addition, Owner designates \_\_\_\_\_ of \_\_\_\_\_  
to receive a copy of the Lessor's Notice as provided in Section 713.13(1)(b), Florida Statutes. Phone number: \_\_\_\_\_
- Expiration Date of Notice of Commencement (The expiration is 1 year from date of recording unless a different date is specified) \_\_\_\_\_

**WARNING TO OWNER:** ANY PAYMENTS MADE BY THE OWNER AFTER THE EXPIRATION OF THE NOTICE OF COMMENCEMENT ARE CONSIDERED IMPROPER PAYMENTS UNDER CHAPTER 713, PART I, SECTION 713.13, FLORIDA STATUTES, AND CAN RESULT IN YOUR PAYING TWICE FOR IMPROVEMENTS TO YOUR PROPERTY. A NOTICE OF COMMENCEMENT MUST BE RECORDED AND POSTED ON THE JOB SITE BEFORE THE FIRST INSPECTION. IF YOU INTEND TO OBTAIN FINANCING, CONSULT WITH YOUR LENDER OR AN ATTORNEY BEFORE COMMENCING WORK OR RECORDING YOUR NOTICE OF COMMENCEMENT.

[Signature] Michele L. Garey  
(Signature of Owner or Lessee or Lender) (Print Name and Printed Signature's Title/Office)

State of Florida County of Orange  
The foregoing instrument was acknowledged before me this 18<sup>th</sup> day of April, 2018  
by Michele Garey Who is personally known to me  OR  
who has produced identification  type of identification produced: R. DL G600 552 86 640 0



JEREMY PEPIN  
NOTARY PUBLIC  
STATE OF FLORIDA  
Comm# GG175773  
Expires 1/16/2022

[Signature]  
Notary Signature



**LIMITED POWER OF ATTORNEY**

I, Boysie Ramdial (Name of Home Depot Qualifier), license # CRC046858, hereinafter referred to as the "License Holder," the qualifying agent of The Home Depot, hereby appoint the following persons as Attorney-in-Fact of the License Holder/The Home Depot, who shall act as my agent with respect to only the following matters (a) signing and submitting building permit applications, (b) obtaining building permits, and (c) obtaining the certificate of occupancy from Belle Isle (pertinent city/county/state) on behalf of the License Holder/The Home Depot:

Brian Kirby

Tim O'Malley

Erick DeDios

Aaron Hallich

David Weed

Christine O'Malley

**LICENSE HOLDER:**

Sign: Boysie le Ramdial

Print Name: Boysie Ramdial

Date: 4/19/18

Title: Regional Compliance Manager

Company Name: Home Depot USA

Mailing Address: 1216 Isben Ave

Orlando, FL 32809

Telephone No.: 404-593-4879

Fax No.: \_\_\_\_\_

State of: Florida

County of: Orange

Michele Garey  
5008 Darden Ave.  
Orlando, FL 32812

**WITNESSES (Two signatures required):**

Sign: [Signature]

Print Name: Jon Thomas

Date: 4/19/18

Sign: [Signature]

Print Name: Amber Holman

Date: 4/19/18

This Limited Power of Attorney is non-durable, meaning it ceases effectiveness if the principal becomes incapacitated.

If I have designated more than one agent, the agents are permitted to act separately.

( ) This power of attorney and authorization shall expire on \_\_\_\_\_

(X) This power of attorney and authorization shall continue in full force and effect until I deliver to you a letter revoking the power or a new Limited Power of Attorney form replacing any previous authorization.

The foregoing instrument was acknowledged before me this 19 day of April, 2018, by Boysie Ramdial, the Qualifier of The Home Depot, a \_\_\_\_\_ corporation, on behalf of the corporation.

[Signature]  
Notary Public



Richie Roberts  
NOTARY PUBLIC  
STATE OF FLORIDA  
Comm# FF958353  
Expires 6/4/2020

Commission Expires: \_\_\_\_\_

American Land Title Association

ALTA Settlement Statement - Combined  
Adopted 05-01-2015

File No./Escrow No.: 18-3360  
 Print Date & Time: 3/29/2018 @ 10:53 AM  
 Officer/Escrow Officer: Rebecca Jenkins  
 Settlement Location:  
 215 E. Colonial Drive  
 Orlando, Florida 32801

Public Title Services, LLC  
 1054803  
 215 E. Colonial Drive  
 Orlando, Florida 32801

Property Address: 5008 Darden Avenue, Orlando, Florida 32812  
 Buyer: Bryan M. Garey and Michele L. Garey, husband and wife  
 Seller: Yalena Shamova as Trustee of 5008 Darden Ave Land Trust dated October 30, 2013  
 Lender: Movement Mortgage, LLC., ISAOA/ATIMA  
 Loan Type: VA Settlement  
 Settlement Date: 3/29/2018  
 Disbursement Date: 3/29/2018  
 Additional dates per state requirements:

Seller		Description	Borrower/Buyer	
Debit	Credit		Debit	Credit
		Financial		
	\$287,500.00	Sales Price of Property	\$287,500.00	
		Deposit including earnest money		\$2,000.00
		Loan Amount		\$296,987.00
		Title - Insurance Seller Credit		\$1,285.00
\$1,285.00		Title - Insurance Seller Credit		
		Prorations/Adjustments		
\$1,068.41		County Taxes from 1/1/2018 to 3/28/2018		\$1,068.41
		Loan Charges to Movement Mortgage, LLC., ISAOA/ATIMA		
		Prepaid Interest ( \$39.67 per day from 3/29/2018 to 4/1/2018 ) to Movement Mortgage, LLC., ISAOA/ATIMA	\$119.01	
		Other Loan Charges		
		Appraisal Fee (POC by Borrower: \$450.00)		
		Credit Report Fee	\$55.75	
		Flood Certification Fee	\$7.00	
		VA Funding Fee	\$9,487.50	
		Impounds		
		Homeowner's Insurance	\$275.88	
		Property Taxes	\$2,578.94	





**Home Depot Contractor License Numbers:**

FL: EC0001440, CGC1514813, CRC046856, CAC1813787, CFC1426021, CFC1427642, 22640, CAC 1818891, CCC1331113, CCC1331130

**Salesperson Name and Registration Number:**

Jeremy Papin :

**Home Improvement Agreement**

Home Depot U.S.A., Inc. ("Home Depot") or Service Provider named below will furnish, install and/or service the equipment listed below at the price, terms and conditions as outlined on this form.

**Customer Information:**

Michele Garey		Tampa	1-5U08CSZ	
First Name	Last Name	Branch Name	Lead #	
5008 Darden Ave, Belle Isle,		Orlando	FL	32812
Customer Address		City	State	Zip
Home Phone#		Work Phone# 3301 907-8370	Cell Phone#	
Customer E-mail Address: ushg309@gmail.com				

**NOTICE OF RIGHT TO CANCEL: YOU MAY CANCEL THIS AGREEMENT WITHOUT PENALTY OR OBLIGATION BY DELIVERING WRITTEN NOTICE TO HOME DEPOT AT:**

3208 Florida Palm Drive	Tampa	FL	33619
Address	City	State	Zip
or Email customercancelatlionsouth@homedepot.com			

**BY MIDNIGHT ON THE THIRD BUSINESS DAY AFTER SIGNING, UNLESS THE STATE SUPPLEMENT PROVIDES A different CANCELLATION PERIOD. THE STATE SUPPLEMENT CONTAINS A FORM TO USE IF ONE IS SPECIFICALLY PRESCRIBED BY LAW IN YOUR STATE. YOUR PAYMENT(S) WILL BE RETURNED WITHIN TEN (10) BUSINESS DAYS AFTER HOME DEPOT'S RECEIPT OF YOUR NOTICE. YOU MUST MAKE AVAILABLE FOR PICKUP BY HOME DEPOT OR PROFESSIONAL, AT YOUR SERVICE ADDRESS, AND IN SUBSTANTIALLY THE SAME CONDITION AS WHEN DELIVERED, ANY MERCHANDISE OR MATERIALS DELIVERED TO YOU. OR YOU MAY CONTACT HOME DEPOT FOR INSTRUCTIONS REGARDING RETURN SHIPMENT AT HOME DEPOT'S EXPENSE.**

**THE LAW REQUIRES THAT THE CONTRACTOR GIVE YOU A NOTICE EXPLAINING YOUR RIGHT TO CANCEL. PLEASE SIGN BELOW TO ACKNOWLEDGE THAT YOU HAVE BEEN GIVEN ORAL AND WRITTEN NOTICE OF YOUR RIGHT TO CANCEL.**

Acknowledged by: *Michele Garey*  
X Customer's Signature

04/18/2018  
Date

**Contract Price and Payment Schedule:** Payment of the Contract Price is due upon completion unless a different payment schedule is specified in the State Supplement.

Contract Price	\$ 10482.65	Includes all applicable discounts, rebates, and , taxes. Excludes finance charges.*
Minimum <sup>25</sup> % deposit	\$ 2615.65	Due Immediately
Remaining balance	\$ 7847.00	Due upon completion

**Finance Charges**

\*Any interest payments or other finance charges will be determined by Customer's separate cardholder or loan agreement, to which The Home Depot is NOT a party, and will be in addition to Customer's payment under this Agreement. Customer is subject to the terms and conditions of the cardholder or loan agreement, as applicable. No funds should be made payable to Service Provider; however, Service Provider may collect Customer's payment(s) made payable to The Home Depot.

Insurance proceeds will  will not  be used to pay some or all of the total amount of sale.

**Description of Work to be Performed:**

Installation of Windows

A more detailed description of the work to be performed is included in the section entitled Scope of Work which appears on page 3 of this Agreement.

**Anticipated Delivery Date / Installation Schedule**

Approximate Start Date: 06/13/2018

Approximate Finish Date: 07/11/2018

All dates are approximate and subject to change based on unforeseen events including inclement weather, permitting delays, and delays in confirming insurance coverage of Your claim for any repair, if applicable.

**Electronic Records Authorization:** You are entitled to a paper copy of this Agreement if you choose. If you consent to an e-mailed copy, your consent applies to this Agreement and all subsequent documents and written communications related to this agreement. By contacting your Service Provider, you may update your email address, withdraw your consent, or obtain a paper copy of the Agreement or related documents at no charge. By providing your consent and verifying your email address above, you confirm that you have access to a computer that can receive and open emails and PDF documents.

By initialing this paragraph, I consent to receive only electronic records related to this transaction.

*[Handwritten Initials]*  
Initial

**Acceptance and Authorization:** By signing below, you authorize Home Depot to (a) arrange for Service Provider to perform Installation and/or (b) order and arrange for the delivery of special order merchandise, including special order merchandise that may be custom made, as specified in this Agreement. Do not sign if blank or incomplete. (Service Provider's/permitting information may need to be provided to You later.) By signing, you acknowledge that you have read, understand, and accept this Agreement in its entirety, including the General Terms and Conditions and State Supplement, if any. You further acknowledge receiving a complete copy of this Agreement. Keep it to protect your legal rights.

X *[Handwritten Signature]*  
Customer's Signature

04/18/2018  
Date

X \_\_\_\_\_  
Co-Signer (if applicable)

\_\_\_\_\_  
Date

X *[Handwritten Signature]*  
Sales Consultant's Signature

04/18/2018  
Date

License number(s) held by or on behalf of the Home Depot:

Date: 04/18/2012

Job #: 1-51108CSZ

Consultant: Jeremy Poplin

Existing Window		Measurements				Ends				Product Options	Lease Options	Hinge Locations						
Room	Floor	Style Code	Wraps (Y/N)	Series Code	Rough Opening		Color	Interior	Exterior	Type (F, S, G, B)	Cohr	Pattern	# of bars			Glass Hardware Screens Mull	Misc Items Code	For doors use "S" = stationary or "X" = operating
					Width	Height							U	Vertical	Horizontal			
1	FAM 1st	PD 2PNL	N	6100	95.25	79.50	WH	WH	WH	174			STD, GlassPack : Standard	LSR	X			Beys Blows Casings, 1 Pnl. Use L, R or S
2	FAM 1st	CF	N	6100	24.00	80.00	WH	WH	WH	104			TMP : Full, GlassPack : Standard	LSR				
3	FAM 1st	CF	N	6100	24.00	80.00	WH	WH	WH	104			MULL, TMP : Full, GlassPack : Standard	LSR				
4	FAM 1st	PD 2PNL	N	6100	95.25	79.50	WH	WH	WH	174			STD, GlassPack : Standard	LSR	X			
5	MIBED 1st	DH	N	6100	52.00	38.00	WH	WH	WH	90			FULL SCR, STD, GlassPack : Standard	LSR				
6	MIBED 1st	DH	N	6100	52.00	38.00	WH	WH	WH	90			FULL SCR, STD, GlassPack : Standard	LSR				
7	MIBED 1st	DH	N	6100	52.00	38.00	WH	WH	WH	90			FULL SCR, STD, GlassPack : Standard	LSR				
8	FAM 1st	TDH	N	6100	74.00	50.00	WH	WH	WH	124			FULL SCR, STD, GlassPack : Standard	LSR				

SPECIAL CONSIDERATIONS:

I have reviewed and agree with all the job specifications above and the Special Terms and Conditions on the following page

Wrap Color	
Interior Casing Type	
Bay or Box window:	
Seatboard material (Vinyl only-3/8" or Oak)	
Bay Project Angle (30 or 45)	
Bay Finer Type (DH, SH, or Cammi)	
Top of window to soffit (inches)	
If tied to soffit, color of soffit material	
Conceal Roof (Yes or No)	
Garden Window:	
Seatboard Material (Vinyl only-White Pluxite, Birch or Oak)	









**ADDITIONAL REMARKS SCHEDULE**

AGENCY MARSH USA, INC		NAMED INSURED THE HOME DEPOT, INC. HOME DEPOT U.S.A., INC. 2455 PACES FERRY ROAD BUILDING C-20 ATLANTA, GA 30389	
POLICY NUMBER		EFFECTIVE DATE:	
CARRIER	NAIC CODE		

**ADDITIONAL REMARKS**

THIS ADDITIONAL REMARKS FORM IS A SCHEDULE TO ACORD FORM,  
FORM NUMBER: 25 FORM TITLE: Certificate of Liability Insurance

RAQUEL G. SWANNER - C6C1514813 and C6C1231113  
JEFF MASTERSON - EC0001440  
RICHARD W. MOORE, JR. - CAC1813167 and CFC1426021  
BOYSIE RANDAL - CRC181858  
BROOK MYERS - CAC1818851

WORKERS COMPENSATION IS COVERED IN THE STATE OF FLORIDA

**\*\*\* HOME DEPOT INSURED \*\*\***

- The Home Depot, Inc.
- The Home Depot U.S.A., Inc.
- Home Depot USA, Inc. dba The Home Depot
- Home Depot USA, Inc. dba Your Other Warehouse, LLC
- Home Depot of Puerto Rico, Inc.
- Home Depot Product Authority, LLC
- Home Depot Store Support, Inc.
- Red Bencil, LLC
- Interline Brands, Inc.
- interline Brands Inc. dba
- Barnet.
- Copperfield
- Eagle Maintenance Supply
- Hardware Express
- Loren
- Maintenance USA
- Renovations Plus
- Supplyworks
- US Lock
- Wimer
- CleanSmile
- JanPak
- AmStar
- Serauer
- Treyco
- Zip Technologies



[BCIS Home](#) | [Log In](#) | [User Registration](#) | [Hot Topics](#) | [Submit Surcharge](#) | [Stats & Facts](#) | [Publications](#) | [FBC Staff](#) | [BCIS Site Map](#) | [Links](#) | [Search](#)



**Product Approval**  
USER: Public User

[Product Approval Menu](#) > [Product or Application Search](#) > [Application List](#) > **Application Detail**



FL #	FLS177-R23
Application Type	Revision
Code Version	2017
Application Status	Approved

\*Approved by DBPR. Approvals by DBPR shall be reviewed and ratified by the POC and/or the Commission if necessary.

Comments  
Archived

Product Manufacturer	Simonton/Ply Gem Windows
Address/Phone/Email	3948 Townsfair Way, Suite 200 Suite 200 Columbus, OH 43219 (614) 532-3596 luanne.harris@plygem.com

Authorized Signature	Luanne Harris luanne.harris@plygem.com
----------------------	---

Technical Representative	Luanne Harris
Address/Phone/Email	1 Cochrane Ave Pennsboro, WV 26415 (614) 532-3596 luanne.harris@simonton.com

Quality Assurance Representative	AAMA
Address/Phone/Email	1827 Walden Office Square Suite 550 Schaumburg, IL 60173 (847) 303-5664 webmaster@aamanet.org

Category	Windows
Subcategory	Fixed

Compliance Method	Certification Mark or Listing
-------------------	-------------------------------

Certification Agency	American Architectural Manufacturers Association
Validated By	American Architectural Manufacturers Association

Referenced Standard and Year (of Standard)	<b>Standard</b>	<b>Year</b>
	AAMA 450	2010
	AAMA/WDMA/CSA 101/I.S 2/A440	2008

Equivalence of Product Standards  
Certified By

Product Approval Method	Method 1 Option A
-------------------------	-------------------

Date Submitted 11/30/2017  
 Date Validated 12/05/2017  
 Date Pending FBC Approval  
 Date Approved 12/09/2017  
 Date Revised 04/13/2018

**Summary of Products**

FL #	Model, Number or Name	Description
5177.1	07-09, 07-10, 07-20 (Retrofit Installation)	Reflections 5500, Impressions 9800, Generations, PerfeXion Platinum Vinyl Fixed Window
<b>Limits of Use</b> Approved for use in HVHZ: No Approved for use outside HVHZ: Yes Impact Resistant: No Design Pressure: N/A Other: 74x63 (+/-55 PSF), 37x84 (+/-50 PSF)		<b>Certification Agency Certificate</b> <a href="#">FL5177 R23 C CAC 07-09 PW 37x84 R PG50 (ext.) pdf</a> <a href="#">FL5177 R23 C CAC 07-09 PW 74x63 LC55.pdf</a> <a href="#">FL5177 R23 C CAC 07-09-10-20 and 08-09-10-20 Waiver.pdf</a> <b>Quality Assurance Contract Expiration Date</b> 06/23/2019 <b>Installation Instructions</b> <a href="#">FL5177 R23 II IN0108 07-09 07-10 07-20 PW 2X.pdf</a> <a href="#">FL5177 R23 II IN0111-R7 07-09 07-10 07-20 PW 1X.pdf</a> Verified By: American Architectural Manufacturers Association Created by Independent Third Party: <b>Evaluation Reports</b> <a href="#">FL5177 R23 AE EvalReport-IN0111-R7-2017.pdf</a> Created by Independent Third Party: Yes
5177.2	07-20 (Nailing Fin Installation)	Reflections 5500, Impressions 9800, Generations, PerfeXion Platinum Vinyl Fixed Window
<b>Limits of Use</b> Approved for use in HVHZ: No Approved for use outside HVHZ: Yes Impact Resistant: No Design Pressure: N/A Other: 96x72 (+/-45 PSF), 37x84 (+/-50 PSF), 74x63 (+/-60 PSF)		<b>Certification Agency Certificate</b> <a href="#">FL5177 R23 C CAC 07-20 PW 96x72 R PG45 (ext.) pdf</a> <a href="#">FL5177 R23 C CAC 07-20 PW 37x84 R50.pdf</a> <a href="#">FL5177 R23 C CAC 07-20 PW 74x63 R PG60 (ext.) pdf</a> <b>Quality Assurance Contract Expiration Date</b> 11/01/2019 <b>Installation Instructions</b> <a href="#">FL5177 R23 II IN0514 07-20 PW 2X.pdf</a> Verified By: American Architectural Manufacturers Association Created by Independent Third Party: <b>Evaluation Reports</b> Created by Independent Third Party:
5177.3	07-75, 07-09, 07-10, 07-20	Reflections 5500, Impressions 9800, Generations, PerfeXion Platinum, 6500 VantagePointe Vinyl Fixed Window
<b>Limits of Use</b> Approved for use in HVHZ: No Approved for use outside HVHZ: Yes Impact Resistant: No Design Pressure: N/A Other: 96x72 (+/-45 PSF), 63x63 (+/-50 PSF), 72x63 (+/-60 PSF)		<b>Certification Agency Certificate</b> <a href="#">FL5177 R23 C CAC 07-09-10-20 and 08-08-10-20 Waiver.pdf</a> <a href="#">FL5177 R23 C CAC 07-75 PW 63x63 LC PG50 (ext. 2).pdf</a> <a href="#">FL5177 R23 C CAC 07-75 PW 72x63 LC PG60 (ext. 2).pdf</a> <a href="#">FL5177 R23 C CAC 07-75 PW 96x72 LC PG45 (ext. 2).pdf</a> <b>Quality Assurance Contract Expiration Date</b> 11/18/2018 <b>Installation Instructions</b> <a href="#">FL5177 R23 II IN0222 07-75 07-09 07-10 07-20 PW 2X.pdf</a> Verified By: American Architectural Manufacturers Association Created by Independent Third Party: <b>Evaluation Reports</b> Created by Independent Third Party:
5177.4	08-08	ProFinish Contractor/Master, PerfeXion Contractor Vinyl Fixed (No Hinge) Casement
<b>Limits of Use</b> Approved for use in HVHZ: No Approved for use outside HVHZ: Yes Impact Resistant: No Design Pressure: N/A Other: 96x72 (+/-25 PSF), 74x63 (+/-55 PSF)		<b>Certification Agency Certificate</b> <a href="#">FL5177 R23 C CAC 08-08 PW (Fin) 74x63 LC PG55.pdf</a> <a href="#">FL5177 R23 C CAC 08-08 PW (Fin) 96x72 LC PG25.pdf</a> <b>Quality Assurance Contract Expiration Date</b> 04/26/2022 <b>Installation Instructions</b> <a href="#">FL5177 R23 II IN0328 08-08 NH 2X.pdf</a> Verified By: American Architectural Manufacturers Association Created by Independent Third Party: <b>Evaluation Reports</b> Created by Independent Third Party:

5177.5	08-09, 08-10, 08-20	Reflections 5500, Generations, Impressions 9800, 6100/6500 VantagePointe, PerfeXion Platinum Vinyl Fixed (No Hinge) Casement
<b>Limits of Use</b> <b>Approved for use in HVHZ:</b> No <b>Approved for use outside HVHZ:</b> Yes <b>Impact Resistant:</b> No <b>Design Pressure:</b> N/A <b>Other:</b> 96x72 (+/-40 PSF), 80x63 (+/-55 PSF)		<b>Certification Agency Certificate</b> <a href="#">FL5177_R23_C_CAC_07-09-10-20_and_08-09-10-20_Waiver.pdf</a> <a href="#">FL5177_R23_C_CAC_08-09_PW_80x63_R_PG55_(ext.2).pdf</a> <a href="#">FL5177_R23_C_CAC_08-09_PW_96x72_R_PG40_(ext.2).pdf</a> <b>Quality Assurance Contract Expiration Date</b> 10/15/2018 <b>Installation Instructions</b> <a href="#">FL5177_R23_II_IN0329_08-09_NH_2X.pdf</a> <a href="#">FL5177_R23_II_IN0456-R3_08-09_NH_1X.pdf</a> Verified By: American Architectural Manufacturers Association Created by Independent Third Party: <b>Evaluation Reports</b> <a href="#">FL5177_R23_AE_EvalReport-IN0456-R3-2017.pdf</a> Created by Independent Third Party: Yes
5177.6	41-18	ProFinish Brickmould 300, PerfeXion BM 300 Vinyl Fixed Window
<b>Limits of Use</b> <b>Approved for use in HVHZ:</b> No <b>Approved for use outside HVHZ:</b> Yes <b>Impact Resistant:</b> No <b>Design Pressure:</b> N/A <b>Other:</b> 96x72 (+/-30 PSF), 96x63 (+/-50 PSF), 80x48 (+/-55 PSF)		<b>Certification Agency Certificate</b> <a href="#">FL5177_R23_C_CAC_41-18_PW_80x48_LC55.pdf</a> <a href="#">FL5177_R23_C_CAC_41-18_PW_96x63_C50.pdf</a> <a href="#">FL5177_R23_C_CAC_41-18_PW_96x72_LC30.pdf</a> <b>Quality Assurance Contract Expiration Date</b> 05/21/2021 <b>Installation Instructions</b> <a href="#">FL5177_R23_II_IN0237_41-18_PW_2X.pdf</a> Verified By: American Architectural Manufacturers Association Created by Independent Third Party: <b>Evaluation Reports</b> Created by Independent Third Party:
5177.7	41-18	ProFinish Brickmould 300, PerfeXion BM 300 Vinyl Fixed Window Twin
<b>Limits of Use</b> <b>Approved for use in HVHZ:</b> No <b>Approved for use outside HVHZ:</b> Yes <b>Impact Resistant:</b> No <b>Design Pressure:</b> N/A <b>Other:</b> 89x63 (+/-30 PSF), 97x80 (+/-40 PSF), 73x74 (+/-50 PSF), 97x80 (+/-25)		<b>Certification Agency Certificate</b> <a href="#">FL5177_R23_C_CAC_41-18_PW_Twin_73x74_R50.pdf</a> <a href="#">FL5177_R23_C_CAC_41-18_PW_Twin_89x63_R30.pdf</a> <a href="#">FL5177_R23_C_CAC_41-18_PW_Twin_97x80_R25.pdf</a> <a href="#">FL5177_R23_C_CAC_41-18_PW_Twin_97x80_R40.pdf</a> <b>Quality Assurance Contract Expiration Date</b> 04/05/2021 <b>Installation Instructions</b> <a href="#">FL5177_R23_II_IN0240_41-18_PW_Triple_2X.pdf</a> Verified By: American Architectural Manufacturers Association Created by Independent Third Party: <b>Evaluation Reports</b> Created by Independent Third Party:
5177.8	41-18	ProFinish Brickmould 300, PerfeXion BM 300 Vinyl Fixed Window Triple
<b>Limits of Use</b> <b>Approved for use in HVHZ:</b> No <b>Approved for use outside HVHZ:</b> Yes <b>Impact Resistant:</b> No <b>Design Pressure:</b> +35/-35 <b>Other:</b> 109x63		<b>Certification Agency Certificate</b> <a href="#">FL5177_R23_C_CAC_41-18_PW_Triple_109x63_R_PG35_(ext.).pdf</a> <b>Quality Assurance Contract Expiration Date</b> 04/26/2022 <b>Installation Instructions</b> <a href="#">FL5177_R23_II_IN0310_41-18_PW_Triple_2X.pdf</a> Verified By: American Architectural Manufacturers Association Created by Independent Third Party: <b>Evaluation Reports</b> Created by Independent Third Party:
5177.9	42-19	ProFinish Brickmould 600, PerfeXion BM 600 Vinyl Fixed Window
<b>Limits of Use</b> <b>Approved for use in HVHZ:</b> No <b>Approved for use outside HVHZ:</b> Yes <b>Impact Resistant:</b> No <b>Design Pressure:</b> N/A <b>Other:</b> 96x72 (+/-35 PSF), 74x63 (+/-50 PSF), 80x48 (+/-50 PSF)		<b>Certification Agency Certificate</b> <a href="#">FL5177_R23_C_CAC_42-19_PW_74x63_R_PG50_(ext.).pdf</a> <a href="#">FL5177_R23_C_CAC_42-19_PW_80x48_R_PG50_(ext.).pdf</a> <a href="#">FL5177_R23_C_CAC_42-19_PW_96x72_R_PG35_(ext.).pdf</a> <b>Quality Assurance Contract Expiration Date</b> 09/08/2019 <b>Installation Instructions</b> <a href="#">FL5177_R23_II_IN0154_42-19_PW_2X.pdf</a> Verified By: American Architectural Manufacturers Association



		Created by Independent Third Party: <b>Evaluation Reports</b> Created by Independent Third Party:
5177.10	42-19	ProFinish Brickmould 600, PerfeXion BM 600 Vinyl Fixed Window Twin
<b>Limits of Use</b> Approved for use in HVHZ: No Approved for use outside HVHZ: Yes Impact Resistant: No Design Pressure: +35/-35 Other: 97x80		<b>Certification Agency Certificate</b> <a href="#">FL5177_R23_C_CAC_42-19_PW_Twin_97x80_R_PG35(ext.).pdf</a> <b>Quality Assurance Contract Expiration Date</b> 11/01/2019 <b>Installation Instructions</b> <a href="#">FL5177_R23_II_IN0155_42-19_PW_Twin_2X.pdf</a> Verified By: American Architectural Manufacturers Association Created by Independent Third Party: <b>Evaluation Reports</b> Created by Independent Third Party:
5177.11	42-19	ProFinish Brickmould 600, PerfeXion BM 600 Vinyl Fixed Window Triple
<b>Limits of Use</b> Approved for use in HVHZ: No Approved for use outside HVHZ: Yes Impact Resistant: No Design Pressure: +35/-35 Other: 109x74		<b>Certification Agency Certificate</b> <a href="#">FL5177_R23_C_CAC_42-19_PW_Triple_109x74_R_PG35(ext.).pdf</a> <b>Quality Assurance Contract Expiration Date</b> 11/01/2019 <b>Installation Instructions</b> <a href="#">FL5177_R23_II_IN0156_42-19_Triple_2X.pdf</a> Verified By: American Architectural Manufacturers Association Created by Independent Third Party: <b>Evaluation Reports</b> Created by Independent Third Party:
5177.12	43-06	ProFinish Builder, PerfeXion Builder, 6060 VantagePointe Vinyl Fixed Window
<b>Limits of Use</b> Approved for use in HVHZ: No Approved for use outside HVHZ: Yes Impact Resistant: No Design Pressure: N/A Other: 96x72 (+/-30 PSF), 96x63 (+/-45 PSF), 72x63 (+/-50 PSF), 48x63 (+/-50)		<b>Certification Agency Certificate</b> <a href="#">FL5177_R23_C_CAC_43-06_PW_(Fin)_72x63_R_PG50(ext.).pdf</a> <a href="#">FL5177_R23_C_CAC_43-06_PW_(Fin)_96x72_LC30.pdf</a> <a href="#">FL5177_R23_C_CAC_43-06_PW_48x63_R50(ext.).pdf</a> <a href="#">FL5177_R23_C_CAC_43-06_PW_96x63_R45(ext.).pdf</a> <b>Quality Assurance Contract Expiration Date</b> 04/02/2019 <b>Installation Instructions</b> <a href="#">FL5177_R23_II_IN0294_43-06_PW_2X.pdf</a> Verified By: American Architectural Manufacturers Association Created by Independent Third Party: <b>Evaluation Reports</b> Created by Independent Third Party:
5177.13	43-17	ProFinish Contractor/Master, PerfeXion Contractor Vinyl Fixed Window
<b>Limits of Use</b> Approved for use in HVHZ: No Approved for use outside HVHZ: Yes Impact Resistant: No Design Pressure: N/A Other: 96x72 (+/-30 PSF), 96x63 (+/-35 PSF), 74x63 (+/-50 PSF), 80x48 (+/-55 PSF)		<b>Certification Agency Certificate</b> <a href="#">FL5177_R23_C_CAC_43-17_PW_(Fin)_74x63_R50.pdf</a> <a href="#">FL5177_R23_C_CAC_43-17_PW_(Fin)_96x63_R35.pdf</a> <a href="#">FL5177_R23_C_CAC_43-17_PW_(Fin)_96x72_CW_PG30(ext.).pdf</a> <a href="#">FL5177_R23_C_CAC_43-17_PW_(Fin-Finless)_80x48_R55.pdf</a> <b>Quality Assurance Contract Expiration Date</b> 12/07/2019 <b>Installation Instructions</b> <a href="#">FL5177_R23_II_IN0088-R3_43-17_PW_1X.pdf</a> <a href="#">FL5177_R23_II_IN0278_43-17_PW_2X.pdf</a> Verified By: American Architectural Manufacturers Association Created by Independent Third Party: <b>Evaluation Reports</b> <a href="#">FL5177_R23_AF_EvalReport-IN0088-R3-2017.pdf</a> Created by Independent Third Party: Yes
5177.14	43-35	6100 VantagePointe, Asure, PerfeXion Silver Vinyl Fixed Window
<b>Limits of Use</b> Approved for use in HVHZ: No Approved for use outside HVHZ: Yes Impact Resistant: No Design Pressure: N/A		<b>Certification Agency Certificate</b> <a href="#">FL5177_R23_C_CAC_43-35_PW_74x63_LC50.pdf</a> <a href="#">FL5177_R23_C_CAC_43-35_PW_80x48_LC50.pdf</a> <a href="#">FL5177_R23_C_CAC_43-35_PW_96x72_LC40.pdf</a> <b>Quality Assurance Contract Expiration Date</b> 09/10/2021

	<p><b>Other:</b> 96x72 (+/-40 PSF), 74x63 (+/-50 PSF), 80x48 (+/-50 PSF)</p>	<p><b>Installation Instructions</b>  <a href="#">FL5177_R23_II_IN0094_43-35_PW_2X.pdf</a>                  Verified By: American Architectural Manufacturers Association                  Created by Independent Third Party:  <b>Evaluation Reports</b>                  Created by Independent Third Party:</p>
<p>5177.15</p>	<p>43-35</p>	<p>6100 VantagePointe, Asure, PerfeXion Silver Vinyl Fixed Window Triple</p>
<p><b>Limits of Use</b>  <b>Approved for use in HVHZ:</b> No  <b>Approved for use outside HVHZ:</b> Yes  <b>Impact Resistant:</b> No  <b>Design Pressure:</b> +50/-50  <b>Other:</b> 109x72</p>		<p><b>Certification Agency Certificate</b>  <a href="#">FL5177_R23_C_CAC_43-35_PW_Triple_109x72_R50(ext.).pdf</a>  <b>Quality Assurance Contract Expiration Date</b>                  01/25/2021  <b>Installation Instructions</b>  <a href="#">FL5177_R23_II_IN0356_43-35_PW_Triple_2X.pdf</a>                  Verified By: American Architectural Manufacturers Association                  Created by Independent Third Party:  <b>Evaluation Reports</b>                  Created by Independent Third Party:</p>
<p>5177.16</p>	<p>43-35</p>	<p>6100 VantagePointe, Asure, PerfeXion Silver Vinyl Fixed Window Twin with Transom</p>
<p><b>Limits of Use</b>  <b>Approved for use in HVHZ:</b> No  <b>Approved for use outside HVHZ:</b> Yes  <b>Impact Resistant:</b> No  <b>Design Pressure:</b> +35/-35  <b>Other:</b> 73x111</p>		<p><b>Certification Agency Certificate</b>  <a href="#">FL5177_R23_C_CAC_43-35_PW_Twin_w_Transom_73x111_R35(ext.).pdf</a>  <b>Quality Assurance Contract Expiration Date</b>                  01/25/2021  <b>Installation Instructions</b>  <a href="#">FL5177_R23_II_IN0355_43-35_PW_Twin_w-Transom_2X.pdf</a>                  Verified By: American Architectural Manufacturers Association                  Created by Independent Third Party:  <b>Evaluation Reports</b>                  Created by Independent Third Party:</p>
<p>5177.17</p>	<p>43-40</p>	<p>Reflections 5050/5300, 6100 Vantage Pointe, PerfeXion Gold Vinyl Fixed Window</p>
<p><b>Limits of Use</b>  <b>Approved for use in HVHZ:</b> No  <b>Approved for use outside HVHZ:</b> Yes  <b>Impact Resistant:</b> No  <b>Design Pressure:</b> N/A  <b>Other:</b> 96x72 (+/-40 PSF), 74x63 (+/-50 PSF), 80x48 (+/-50 PSF)</p>		<p><b>Certification Agency Certificate</b>  <a href="#">FL5177_R23_C_CAC_43-40_PW_74x63_LC50.pdf</a>  <a href="#">FL5177_R23_C_CAC_43-40_PW_80x48_LC50.pdf</a>  <a href="#">FL5177_R23_C_CAC_43-40_PW_96x72_LC40.pdf</a>  <b>Quality Assurance Contract Expiration Date</b>                  10/05/2021  <b>Installation Instructions</b>  <a href="#">FL5177_R23_II_IN0094_43-40_PW_2X.pdf</a>                  Verified By: American Architectural Manufacturers Association                  Created by Independent Third Party:  <b>Evaluation Reports</b>                  Created by Independent Third Party:</p>

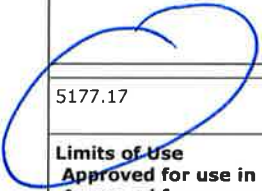

[Back](#) [Next](#)

Contact Us :: 2601 Blair Stone Road, Tallahassee FL 32399 Phone: 850-487-1824

The State of Florida is an AA/EEO employer. [Copyright 2007-2013 State of Florida.](#) :: [Privacy Statement](#) :: [Accessibility Statement](#) :: [Refund Statement](#)

Under Florida law, email addresses are public records. If you do not want your e-mail address released in response to a public-records request, do not send electronic mail to this entity. Instead, contact the office by phone or by traditional mail. If you have any questions, please contact 850.487.1395. \*Pursuant to Section 455.275(1), Florida Statutes, effective October 1, 2012, licensees licensed under Chapter 455, F.S. must provide the Department with an email address if they have one. The emails provided may be used for official communication with the licensee. However email addresses are public record. If you do not wish to supply a personal address, please provide the Department with an email address which can be made available to the public. To determine if you are a licensee under Chapter 455, F.S., please click [here](#).



**MODEL DESIGNATION:** Simonton Series 43-35 Vinyl Fixed Window

**MAXIMUM OVERALL NOMINAL SIZE:** See Size Chart

**DESIGN PRESSURE RATING:** See Size Chart

**USABLE CONFIGURATIONS:** 0

**GENERAL DESCRIPTION:** The head, sill, and side jambs are extruded PVC. The wall thickness through which the anchor screw penetrates is a minimum of 0.070".

NO P.E. SEAL REQUIRED  
INSTALLATION SUPPORTED  
BY AAMA TEST REPORTS

REV. #	REVISIONS:	REVISED BY:	DATE:
2	ADDED "NO PE SEAL REQUIRED" & "43-40 ONLY" NOTES	T.D.D.	10/17/08
3	UPDATED SIZE CHART PER TEST REPORT #86427.01.	T.D.D.	11/23/09
4	UPDATED NOTES AND GENERAL DESCRIPTION.	T.D.D.	03/31/11
5	ADDED GLAZING DETAILS.	T.D.D.	06/08/11
6	CHANGED SASH-FRAME CODE AND FRAME PROFILES PER NEW TESTING.	T.D.D.	02/23/12
7	ADDED MIN. EDGE DIST. NOTES	GJM	06/17/15

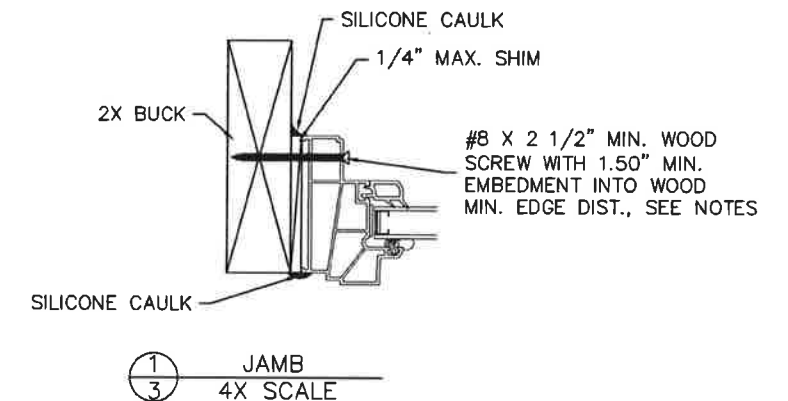
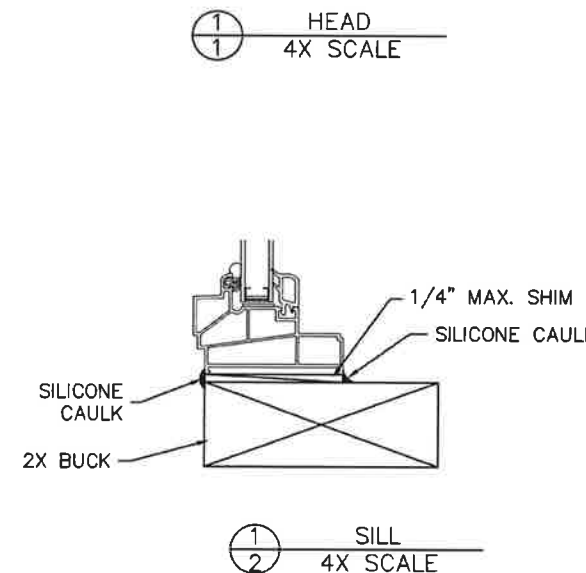
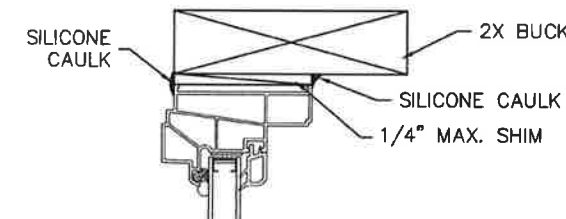
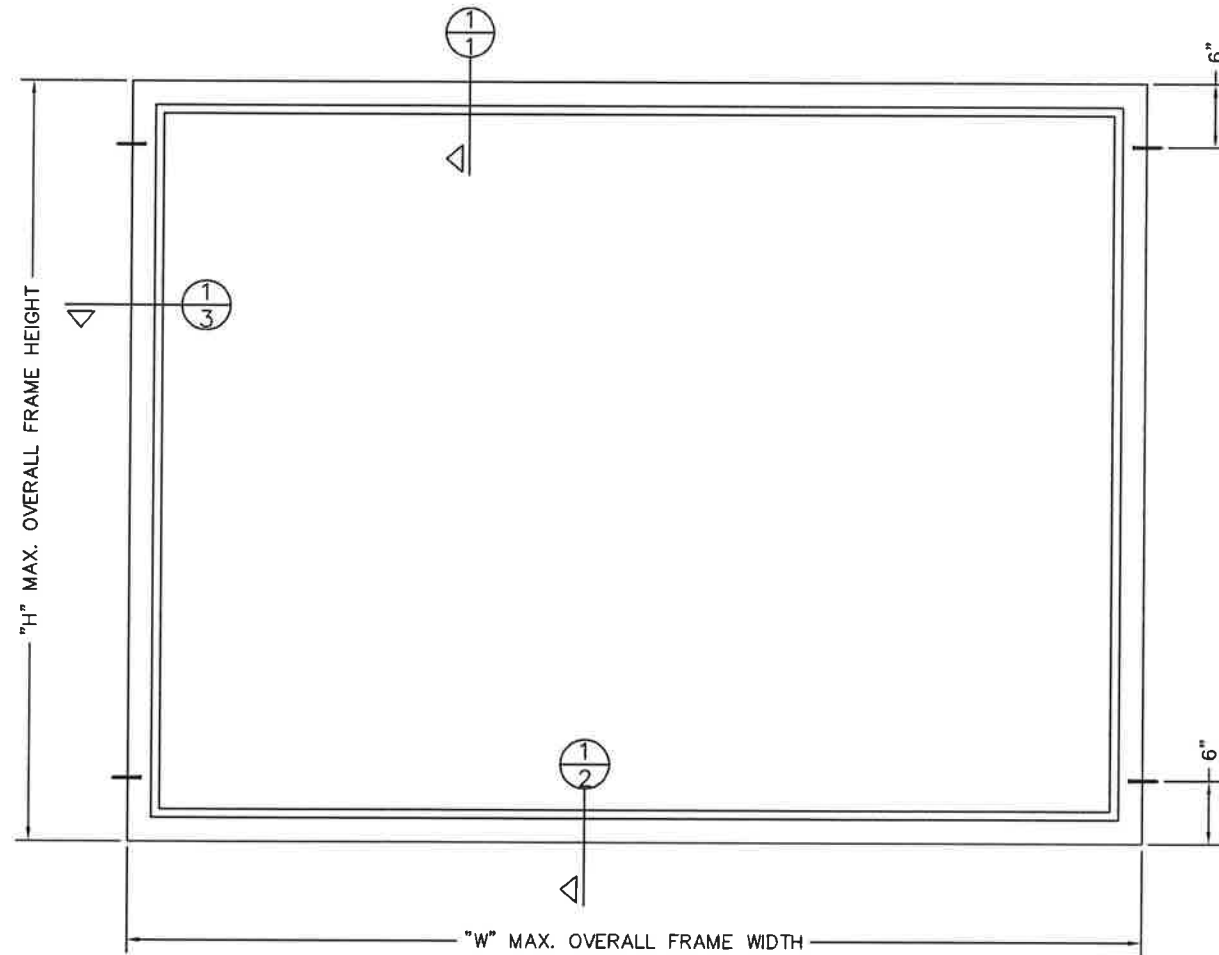

OVERALL SIZE		DP RATING
WIDTH "W"	HEIGHT "H"	
96"	72"	±40 PSF
74"	63"	±50 PSF
80"	48"	

**NOTES:**

- This installation has been evaluated for use in locations adhering to the Florida Building Codes and where pressure requirements as determined by ASCE 7 Minimum Design Loads for Buildings and Other Structures do not exceed the design pressure ratings herein, for use outside the H.V.H.Z.
- All exterior perimeter surfaces of the window must be caulked. Interior caulking is optional unless noted otherwise.
- Anchors shall be as specified and spaced as shown. Anchor embedment to base material shall be beyond wall dressing or stucco and into wood.
- The responsibility for selection of Simonton products to meet any applicable local laws, building codes, ordinances, or other safety requirements rests solely with the architect, building owner, or contractor.
- Shims are optional. Max. shim stack is 1/4".
- Wood bucks (by others) must be engineered and anchored properly to transfer loads to the structure.
- When used in areas requiring impact protection this product **REQUIRES** the use of approved impact resistant shutters or other external protection.
- Flashing should be applied using the ASTM E 2112 methodology appropriate for the opening into which the window is being installed.
- Installation screws must be at least 3/4" from the edge of the wood.
- Glazing shall comply with ASTM E 1300-04.

<p><b>DISCLOSURE STATEMENT</b></p> <p>This document is the property of Simonton Windows, which retains all proprietary and other rights to its subject matter. This document is provided to the recipient on the expressed condition that it is not to be disclosed, reproduced in whole or part, nor used in conjunction with the design, manufacture or repair of goods for anyone other than Simonton Windows without its consent. This restriction does not limit the recipient's rights to utilize information contained in this document which is properly obtained from another source.</p> <p>FILE: IN0094</p>	<p><b>MATERIAL:</b></p> <p>RMS FINISH: _____</p> <p>ALLOY &amp; TEMPER: _____</p> <p>WEIGHT: _____ VOLUME: _____</p> <p>SURFACE AREA: _____ PERIMETER: _____</p> <p>FINISH TREATMENT: _____</p>	<p>Dimensional Tolerances Unless Otherwise Specified</p> <p>Decimals      Angles</p> <p>.X ± .03 .XX ± .01 .XXX ± .005</p> <p>0' 30 min.</p>	<p><b>SIMONTON</b> WINDOWS</p> <p>1 Cochrane Avenue Pennsboro, WV 26415</p> <p>SCALE: FIT      SHEET: 1 of 1</p> <p>SERIES: 43-35 PICTURE (FIXED) WINDOW</p> <p>TITLE: 2X BUCK INSTALLATION</p>	<p>SIZE: DRAWING NO.: B IN0094      REV.: 7</p> <p>DRAWN BY: G.L.S.      DATE: 11/9/06</p> <p>CHECKED BY: _____      DATE: _____</p> <p>APPR'VD BY: _____      DATE: _____</p>
--	---	--	---	--

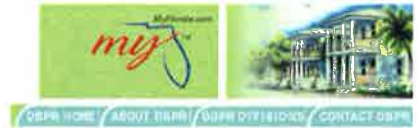

[BCIS Home](#) | 
 [Log In](#) | 
 [User Registration](#) | 
 [Hot Topics](#) | 
 [Submit Surcharge](#) | 
 [Stats & Facts](#) | 
 [Publications](#) | 
 [FBC Staff](#) | 
 [BCIS Site Map](#) | 
 [Links](#) | 
 [Search](#)



**Product Approval**  
 USER: Public User

[Product Approval Menu](#) > 
 [Product or Application Search](#) > 
 [Application List](#) > 
 **Application Detail**



FL #	FL14787-R3
Application Type	Revision
Code Version	2017
Application Status	Approved
Comments	
Archived	<input type="checkbox"/>
Product Manufacturer	Simonton/Ply Gem Windows
Address/Phone/Email	3948 Townsfair Way, Suite 200 Suite 200 Columbus, OH 43219 (614) 532-3596 luanne.harris@plygem.com
Authorized Signature	Luanne Harris luanne.harris@plygem.com
Technical Representative	Luanne Harris
Address/Phone/Email	3948 Townsfair Way Suite 200 Columbus, OH 43219 (614) 532-3596 luanne.harris@simonton.com
Quality Assurance Representative	AAMA
Address/Phone/Email	1827 Walden Office Square Suite 550 Schaumburg, IL 60173 (847) 303-5664 webmaster@aamanet.org
Category	Windows
Subcategory	Mullions
Compliance Method	Evaluation Report from a Florida Registered Architect or a Licensed Florida Professional Engineer <input type="checkbox"/> Evaluation Report - Hardcopy Received
Florida Engineer or Architect Name who developed the Evaluation Report	Lucas A. Turner
Florida License	PE-58201
Quality Assurance Entity	Architectural Testing, Inc., an Intertek company
Quality Assurance Contract Expiration Date	12/31/2020
Validated By	Scott Wolters, PE <input checked="" type="checkbox"/> Validation Checklist - Hardcopy Received
Certificate of Independence	<a href="#">FL14787_R3_COI_EvalReport-RM0015Br7.pdf</a>
Referenced Standard and Year (of Standard)	
Equivalence of Product Standards Certified By	
Sections from the Code	

1709.8

Product Approval Method	Method 2 Option B
Date Submitted	10/12/2017
Date Validated	10/18/2017
Date Pending FBC Approval	10/20/2017
Date Approved	12/12/2017

**Summary of Products**

FL #	Model, Number or Name	Description
14787.1	Reinforced Stand Alone Mullions Non-Impact	Extruded Vinyl Mullions with Aluminum Reinforcement
<b>Limits of Use</b> <b>Approved for use in HVHZ:</b> No <b>Approved for use outside HVHZ:</b> Yes <b>Impact Resistant:</b> No <b>Design Pressure:</b> N/A <b>Other:</b> Design pressure ratings vary by unit and mullion size. See installation drawings for applicable design pressure rating.		<b>Installation Instructions</b> <a href="#">FL14787_R3_II_RM0015Br7.pdf</a> Verified By: Lucas A.Turner PE #58201 Created by Independent Third Party: Yes <b>Evaluation Reports</b> <a href="#">FL14787_R3_AE_EvalReport-RM0015Br7.pdf</a> Created by Independent Third Party: Yes

[Back](#) [Next](#)

Contact Us :: [2601 Blair Stone Road, Tallahassee FL 32399](#) Phone: 850-487-1824

The State of Florida is an AA/EEO employer. [Copyright 2007-2013 State of Florida.](#) :: [Privacy Statement](#) :: [Accessibility Statement](#) :: [Refund Statement](#)

Under Florida law, email addresses are public records. If you do not want your e-mail address released in response to a public-records request, do not send electronic mail to this entity. Instead, contact the office by phone or by traditional mail. If you have any questions, please contact 850.487.1395. \*Pursuant to Section 455.275(1), Florida Statutes, effective October 1, 2012, licensees licensed under Chapter 455, F.S. must provide the Department with an email address if they have one. The emails provided may be used for official communication with the licensee. However email addresses are public record. If you do not wish to supply a personal address, please provide the Department with an email address which can be made available to the public. To determine if you are a licensee under Chapter 455, F.S., please click [here](#).



Credit Card  
**Safe**







COCHRANE AVE, PENNSBORO, WV 26415  
PH. 800-426-2249

EXTRUDED NON-IMPACT VINYL MULLIONS  
WITH ALUMINUM REINFORCEMENT  
ALL NON-IMPACT WINDOW SERIES

REVISIONS

REV.	DESCRIPTION	DATE	BY
3	Revised per 2007 Florida Building Code, Added Sheet 8.	04/15/2011	JRM
4	Revised per 2010 Florida Building Code, updated general notes shf.1.	01/20/2012	CAP
5	Updated DP ratings chart and added new mullion covers.	06/20/2012	T.J.D.
6	Revised per 5th Ed. (2014) FBC	04/25/2015	LAT
7	Updated Note 1, Sheet 1	10/03/2017	LMH

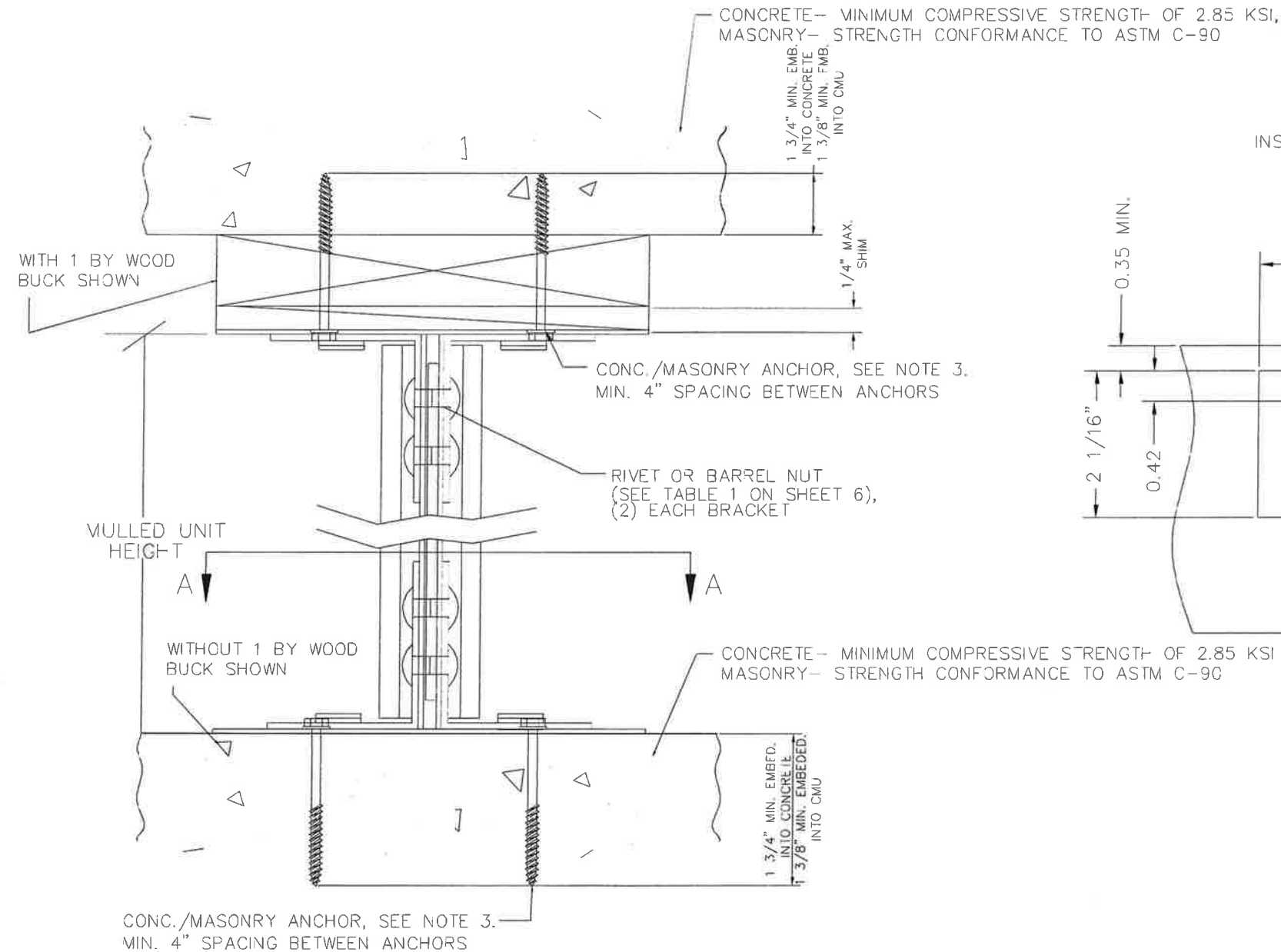

VERTICAL CROSS SECTION WITH  
MASONRY/CONCRETE SUBSTRATE

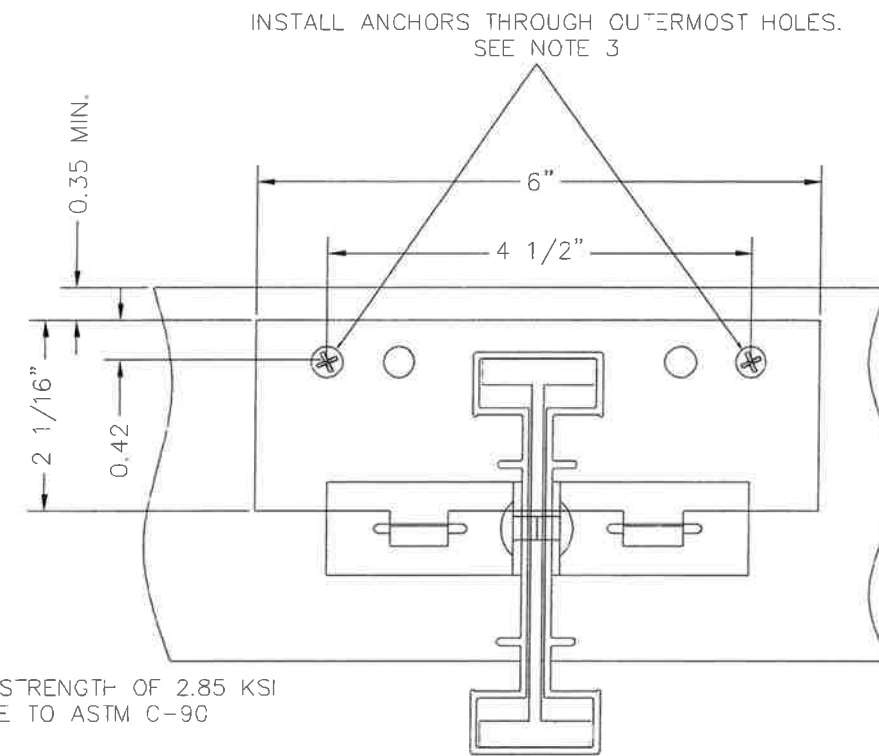

SECTION A-A

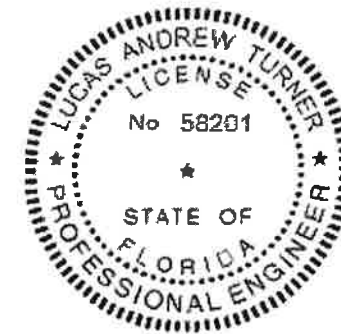

NOTES:

- THE MULLION PRODUCTS AND THEIR INSTALLATION COMPLY WITH FBC STRUCTURAL REQUIREMENTS AND ARE LIMITED TO USE OUTSIDE THE HVHZ.
- THE MULLIONS SHALL BE USED IN CONNECTION WITH FBC APPROVED PRODUCTS.
- ANCHORS IN GROUT-FILLED CMU BLOCK (ASTM C-90 COMPLIANT) SHALL BE 1/4" ELCC ULTRACONS WITH 1 3/8" MIN. EMBED. TO BLOCK, AND 1" MIN. EDGE DIST. ANCHORS IN SOLID CONCRETE (2.85 KSI MIN.) SHALL BE 3/16" ITW TAPCONS OR 1/4" ELCO ULTRACONS WITH 1 3/4" MIN. EMBED. TO CONCRETE, AND 1 1/8" MIN. EDGE DIST.
- ATTACHMENT OF ALL 2X TREATED WOOD BUCKS SHALL BE ENGINEERED SEPARATELY BY OTHERS.
- WOOD SHALL BE TREATED 2X SPRUCE, PINE, OR FIR.
- BASE PLATES AND L-BRACKETS ARE STAINLESS STEEL CONFORMING TO ANSI 302/304.
- SIMILAR INSTALLATIONS ARE USED ON HEAD AND SILL.
- WHEN INSTALLED IN LOCATIONS WHERE WINDBORNE DEBRIS PROTECTION IS REQUIRED, USE OF AN IMPACT PROTECTIVE SYSTEM IS REQUIRED.

	DATE: 10/3/2017	SCALE: 0.75"	SHEET: 8 of 8
	LUCAS A. TURNER, P.E. FL PE #58291 TURNER ENGINEERING & CONSULTING, INC. FBPE C.O.A. #29779 Ph. 941-380-1574 1239 JABARA AVE. NORTH PORT, FL 34288		TITLE: REINFORCED VINYL MULLIONS APPROVED BY: CAP DATE: 01/20/12





COCHRANE AVE. PENNSBORO, WV 26415  
PH. 800-426-2249

EXTRUDED NON-IMPACT VINYL MULLIONS  
WITH ALUMINUM REINFORCEMENT  
ALL NON-IMPACT WINDOW SERIES

REVISIONS

REV.	DESCRIPTION	DATE	BY
3	Revised per 2007 Florida Building Code, Added Sheet 8.	04/15/2011	JRM
4	Revised per 2010 Florida Building Code, updated general notes shf.1.	01/20/2012	CAP
5	Updated DP ratings chart and added new mullion covers.	06/20/2012	T.J.D.
6	Revised per 5th Ed. (2011) FBC	01/25/2015	LAT
7	Updated Note 1, Sheet 1	10/03/2017	LMH

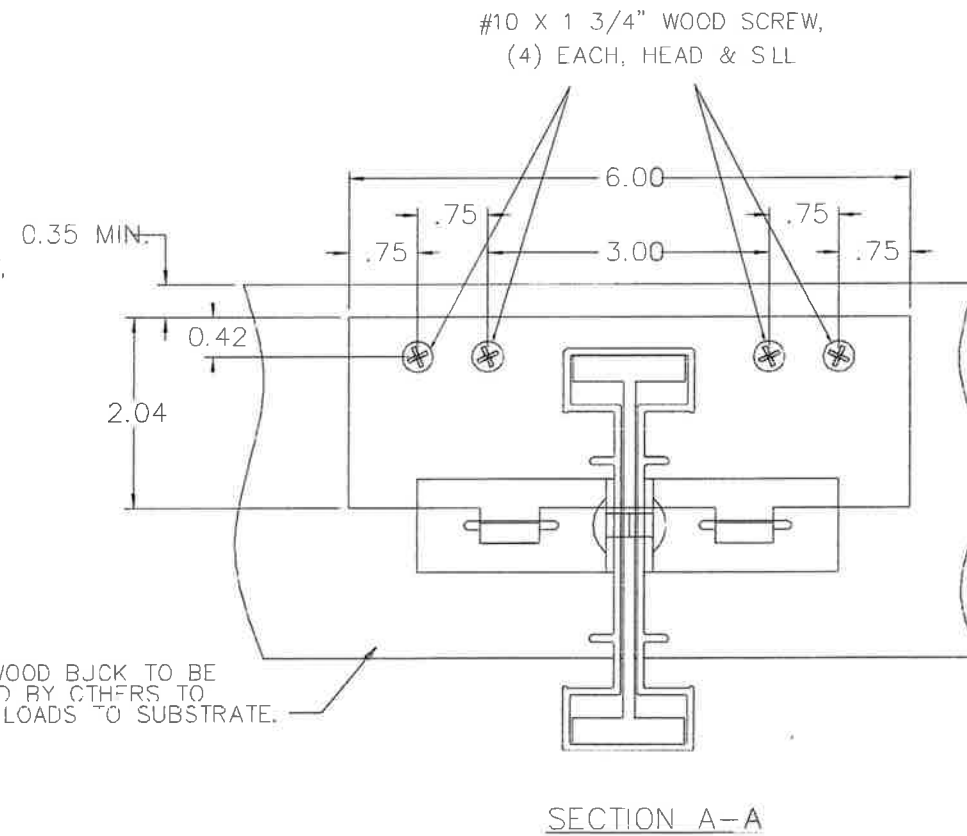
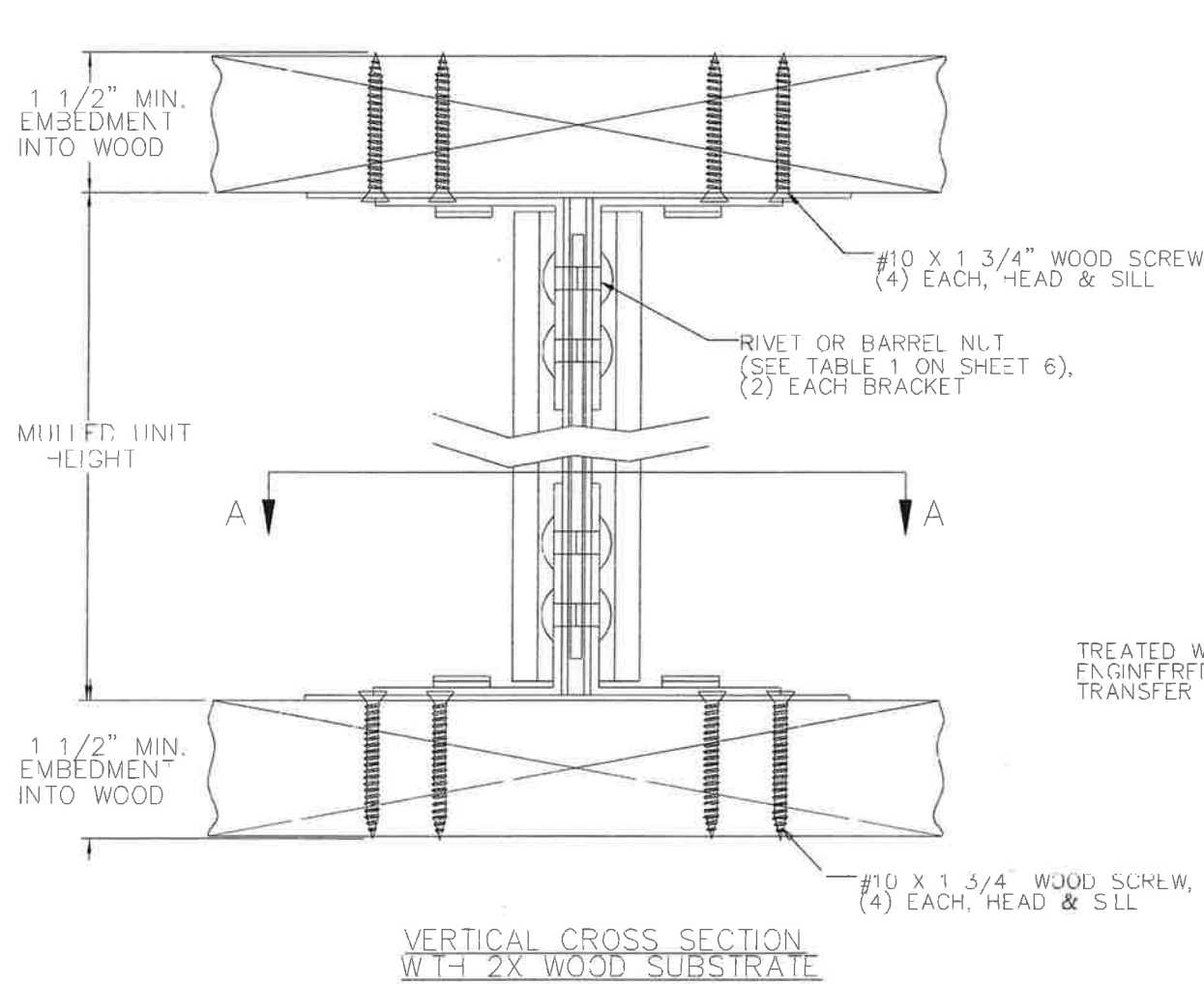

NOTES:

1. THE MULLION PRODUCTS AND THEIR INSTALLATION COMPLY WITH FBC STRUCTURAL REQUIREMENTS AND ARE LIMITED TO USE OUTSIDE THE HVHZ.
2. THE MULLIONS SHALL BE USED IN CONNECTION WITH FBC APPROVED PRODUCTS.
3. ANCHORS SHALL HAVE 1 1/2" MINIMUM EMBEDMENT INTO WOOD AND 7/8" MINIMUM WOOD EDGE DISTANCE.
4. ATTACHMENT OF ALL 2X TREATED WOOD BACKS SHALL BE ENGINEERED SEPARATELY BY OTHERS.
5. WOOD SHALL BE TREATED 2X SPRUCE, PINE, OR FIR.
6. #10 WOOD SCREWS SHALL BE STEEL CONFORMING TO ASTM A 653.
7. BASE PLATES AND L-BRACKETS ARE STAINLESS STEEL CONFORMING TO ANSI 302/304.
8. SIMILAR INSTALLATIONS ARE USED ON HEAD AND SILL.
9. WHEN INSTALLED IN LOCATIONS WHERE WINDBORNE DEBRIS PROTECTION IS REQUIRED, USE OF AN IMPACT PROTECTIVE SYSTEM IS REQUIRED.

ZZ	10/3/2017		SCALE: C.75"	DATE: 01/20/12
			TITLE: REINFORCED VINYL MULLIONS	DATE: 01/20/12
LUCAS A. TURNER, P.E. FL. REG. #58201 TURNER ENGINEERING & CONSULTING, INC. 1239 JABARA AVE., NORTH PORT, FL 34289		DRAWN BY: RTW CHECKED BY: TOD APPROVED BY: CAP		

**SIMONTON**  
 COCHRANE AVE. PENNSBORO, WV 26415  
 PH. 800-426-2249

EXTRUDED NON-IMPACT VINYL MULLIONS  
 WITH ALUMINUM REINFORCEMENT  
 ALL NON-IMPACT WINDOW SERIES

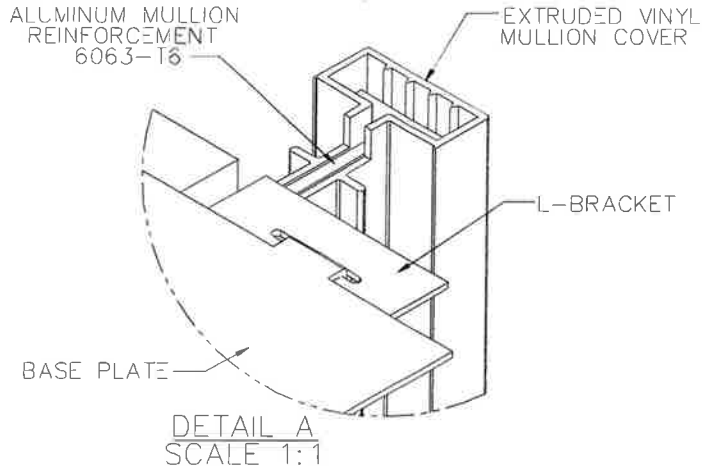

DETAIL A  
 SCALE 1:1

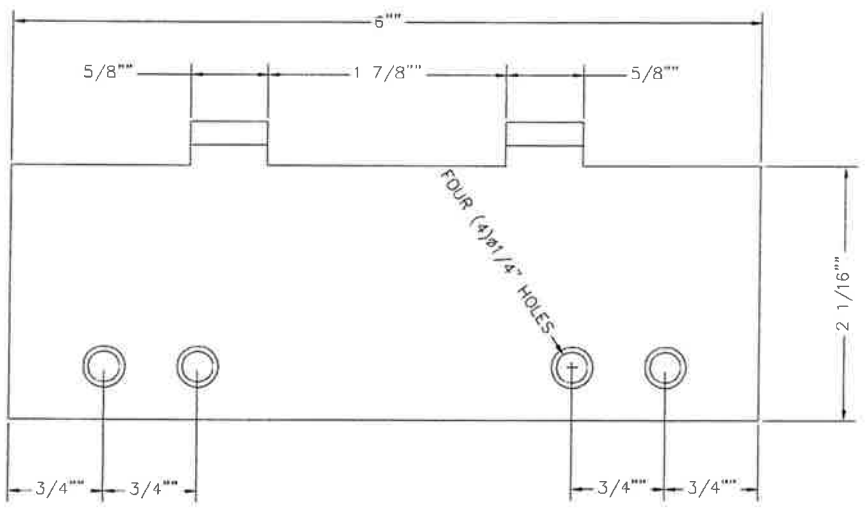

REINFORCEMENT BASE PLATE DETAIL  
 .060" MIN. STAINLESS STEEL  
 ANSI 302/304

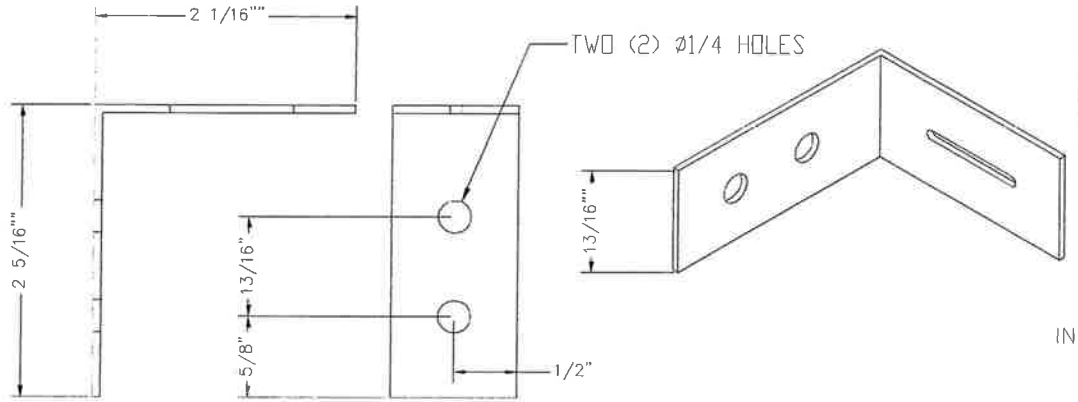

REINFORCEMENT L-BRACKET  
 0.076" MIN. STAINLESS STEEL  
 ANSI 302/304

SEE MANUFACTURER'S INSTALLATION INSTRUCTIONS FOR ATTACHING REINFORCED MULLIONS TO WINDOW UNITS. TYPICALLY, USE SELF-TAPPING SCREW OF SUFFICIENT LENGTH TO FULLY ENGAGE THREADS THROUGH THE ALUMINUM REINF., AT THE ANCHOR SIZE AND SPACING INDICATED IN THE APPLICABLE WINDOW PRODUCT APPROVAL FOR ATTACHMENT TO WOOD SUBSTRATE.



SEE MANUFACTURER'S ATTACHMENT INSTRUCTIONS FOR ATTACHING REINFORCED MULLIONS TO WINDOW UNITS

REVISIONS			
REV.	DESCRIPTION	DATE	BY
3	Revised per 2007 Florida Building Code, Added Sheet 8.	04/15/2011	JRM
4	Revised per 2010 Florida Building Code, updated general notes shf.1.	01/20/2012	CAP
5	Updated DP ratings chart and added new mullion covers.	06/20/2012	T.J.D.
6	Revised per 5th Ed. (2014) FBC	04/25/2013	LAT
7	Updated Note 1, Sheet 1	10/03/2017	LMH

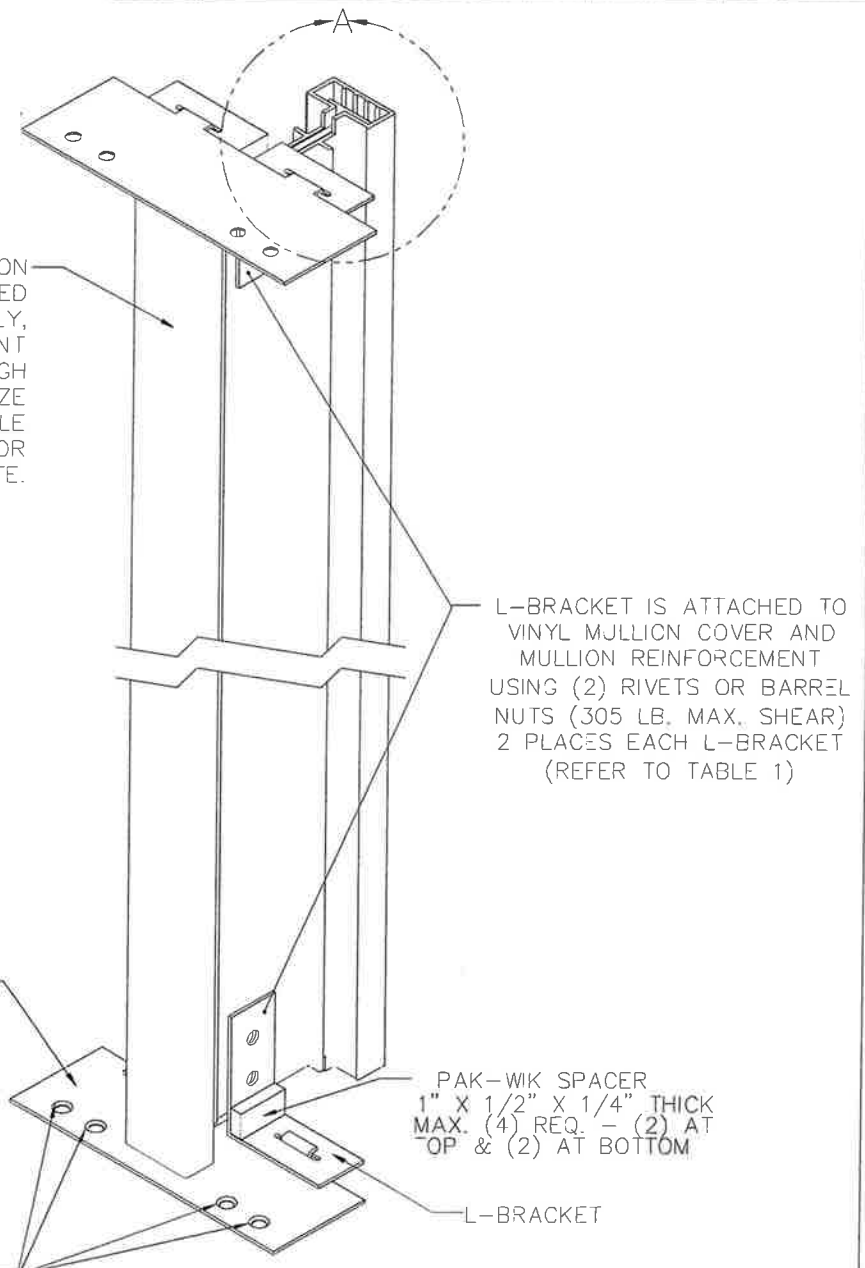

ASSEMBLED MULLION ATTACHMENT VIEW

TABLE 1 - MULLION ATTACHING HARDWARE

RIVET	.25 DIA. STEEL RIVET WITH A GRIP LENGTH OF .50 MAX.
BARREL NUT	#10-24 OR #10-32 STAINLESS STEEL BARREL NUT, .250 O.D. X .25" LG WITH .125 MIN ENGAGEMENT

- NOTES:
- WOOD FRAME: USE (4) #10 X 1 3/4" WOOD SCREWS AT THE HEAD AND SILL THROUGH BASE PLATES, WITH 1-1/2" MINIMUM EMBEDMENT INTO WOOD FOR MULLION ATTACHMENT. SEE SHEET 7 FOR DETAILS.
  - MASONRY/CONCRETE: USE (2) ITW TAPCON OR ELCO ULTRACON ANCHORS AT HEAD AND SILL THROUGH BASE PLATES. SEE SHEET 8 FOR DETAILS.
  - TWO (2) RIVETS OR BARREL NUTS ARE REQUIRED TO ATTACH L-BRACKETS TO ALUMINUM MULLION. SEE TABLE 1 (THIS SHEET).

12

10/3/2017

LUCAS A. TURNER, P.E. FL PE #58201  
 TURNER ENGINEERING & CONSULTING, INC.  
 FBPE C.O.A. #29779 Ph. 941-380-1574  
 1239 JABARA AVE. NORTH PORT, FL 34288

**SIMONTON**  
 WINDOWS

SCALE: C. 75' SHEET 6 of 8

DATE: 3-2C-08  
 DATE: 12/18/08  
 DATE: 01/20/12

DRWN BY: RTW  
 CHECKED BY: TDD  
 APPR'D BY: CAP

SHEET: RM0015B 7  
 SERIES: ALL MILLED PRODUCTS  
 FILE: REINFORCED VINYL MULLIONS



COCHRANE AVE. PENNSBORO, WV 26415  
PH. 800-426-2249

EXTRUDED NON-IMPACT VINYL MULLIONS  
WITH ALUMINUM REINFORCEMENT  
ALL NON-IMPACT WINDOW SERIES

REVISIONS			
REV.	DESCRIPTION	DATE	BY
3	Revised per 2007 Florida Building Code, Added Sheet 8	04/15/2011	JRM
4	Revised per 2010 Florida Building Code, updated general notes shf.1.	01/20/2012	CAP
5	Updated DP ratings chart and added row mullion covers.	06/20/2012	T.J.D.
6	Revised per 5th Ed. (2014) NBC	04/25/2013	LAT
7	Updated Note 1, Sheet 1	10/03/2017	LMH

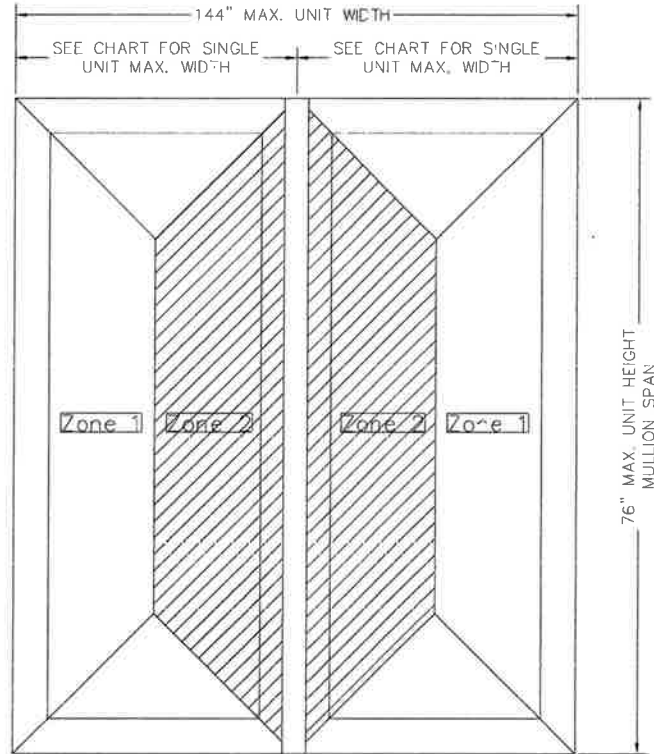

TABLE D - MAXIMUM DESIGN PRESSURES (PSF)  
MULLION # 20634

Mullion Length	Individual Unit Width													
	24	28	32	36	40	44	48	52	56	60	64	68	72	
40	75	75	75	75	75	75	75	75	75	75	75	75	75	
44	75	75	75	75	75	75	75	75	75	75	75	75	75	
48	75	75	75	75	75	75	75	75	75	75	75	75	75	
52	75	75	75	75	75	75	75	75	75	75	75	75	75	
56	75	75	75	70	65	60	60	60	60	60	60	60	60	
60	75	65	60	55	50	50	45	45	45	45	45	45	45	
64	60	55	50	45	40	40	35	35	35	35	35	35	35	
68	50	45	40	35	30	30	30	25	25	25	25	25	25	
72	40	35	30	30	25	25	25	20	20	20	20	20	20	
76	35	30	25	25	20	20	20	20	15	15	15	15	15	

MAXIMUM SINGLE WINDOW WIDTH

WINDOW TYPE	WINDOW WIDTH
DOUBLE HUNG	56"
HORIZONTAL SLIDER	72"
CASEMENT	36"
FIXED	96"

MULLION TRIBUTARY WIDTH - SUM  
OF ZONE 2 WINDOW WIDTHS

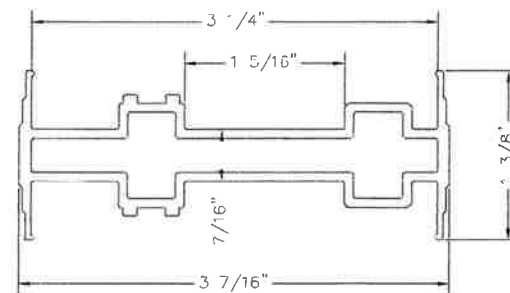

MEDIUM H-MULLION VINYL COVER #VPI-436  
FOR ANY RETROFIT HOOKED FRAME  
EXTRUDED VINYL .070" MIN.

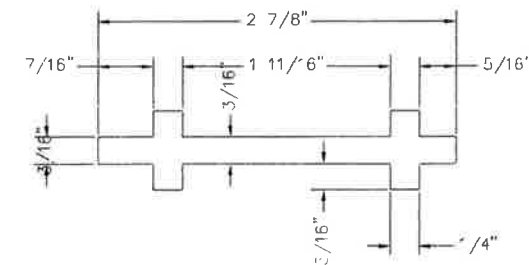

MED JM MULL REINFORCEMENT #20634  
ALUMINUM 6063-T6

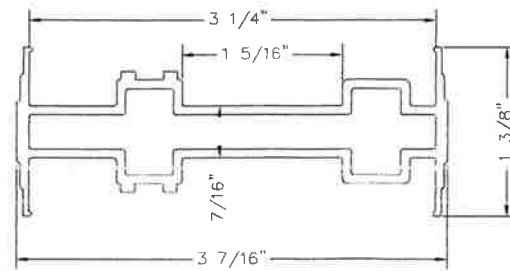

MEDIUM H-MULLION VINYL COVER #VPI-436  
FOR ANY RETROFIT HOOKED FRAME  
EXTRUDED VINYL .070" MIN.



SEE NOTES SHEETS 6, 7, AND 8 FOR REQUIRED ANCHORAGE INFORMATION.

27

16/3/2017

LUCAS A. TURNER, P.E. FL #58201  
TURNER ENGINEERING & CONSULTING, INC.  
1239 JABARA AVE. NORTH PORT, FL 34288

SCALE: C, 75% SHEET 5 of 8

SIMONTON WINDOWS

SERIES: ALL MULLED PRODUCTS  
TITLE: REINFORCED VINYL MULLIONS

DATE	01/20/12
APPROVED BY	CAP
DATE	12/18/08
ENTERED BY	TDD
DATE	3-20-08
DRAWN BY	RTW
GRAPHIC NUMBER	RM0015B 7

**SIMONTON**  
WINDOWS  
1 COCHRANE AVE. PENNSBORO, WV 26415  
PH. 800-426-2249

EXTRUDED NON-IMPACT VINYL MULLIONS  
WITH ALUMINUM REINFORCEMENT  
ALL NON-IMPACT WINDOW SERIES

REVISIONS			
REV.	DESCRIPTION	DATE	BY
3	Revised per 2007 Florida Building Code, Added Sheet 8.	04/15/2011	JRM
4	Revised per 2010 Florida Building Code, updated general notes sht.1.	01/20/2012	CAP
5	Updated DP ratings chart and added new mullion covers.	06/20/2012	T.D.D.
6	Revised per 5th Ed. (2014) FBC	04/25/2015	LAT
7	Updated Note 1, Sheet 1	10/03/2017	LMH

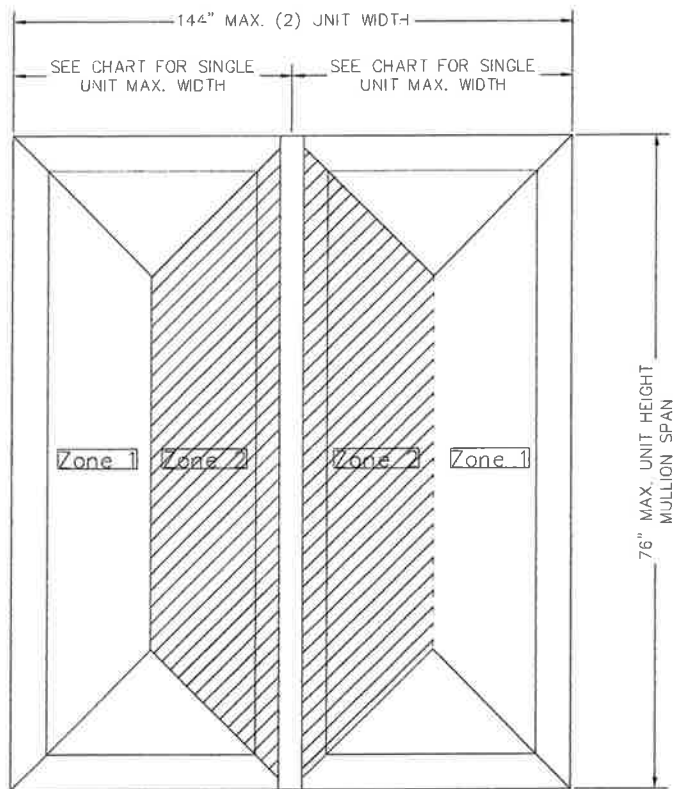

TABLE C - MAXIMUM DESIGN PRESSURES (PSF)  
MULLION #16990

		Individual Unit Width												
		24	28	32	36	40	44	48	52	56	60	64	68	72
Mullion Length	40	75	75	75	75	75	75	75	75	75	75	75	75	75
	44	75	75	75	75	75	75	75	75	75	75	75	75	75
	48	75	75	75	75	75	75	75	75	75	75	75	75	75
	52	75	75	75	75	75	75	75	70	70	70	70	70	70
	56	75	75	70	65	60	60	55	55	55	55	55	55	55
	60	70	60	55	50	50	45	45	40	40	40	40	40	40
	64	60	50	45	40	40	35	35	35	30	30	30	30	30
	68	45	40	35	35	30	30	25	25	25	25	25	25	25
	72	40	35	30	25	25	25	20	20	20	20	20	20	20
	76	35	30	25	20	20	20	20	15	15	15	15	15	15

MAXIMUM SINGLE WINDOW WIDTH

WINDOW TYPE	WINDOW WIDTH
SINGLE HUNG	52"
DOUBLE HUNG	56"
HORIZONTAL SLIDER	72"
CASEMENT	36"
FIXED	96"

MULLION TRIBUTARY WIDTH = SUM OF ZONE 2 WINDOW WIDTHS

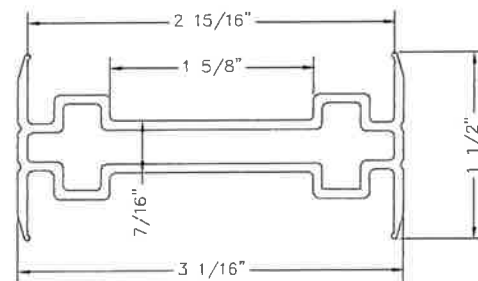

MEDIUM H-MULLION VINYL COVER #V346A  
ALL NEW CONSTRUCTION  
EXTRUDED VINYL .071" MIN.

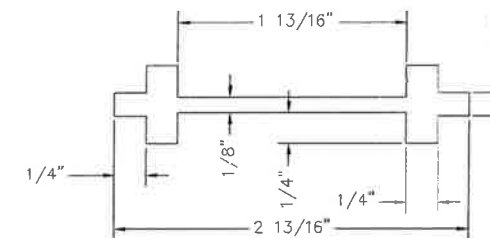

MEDIUM MULL REINFORCEMENT #16990  
ALUMINUM 6063-T6

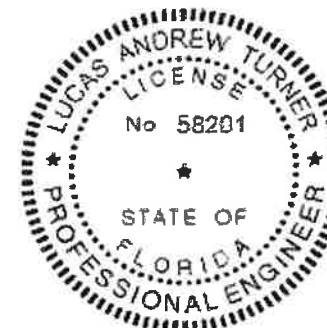

SEE NOTES SHEETS 6, 7, AND 8 FOR REQUIRED ANCHORAGE INFORMATION.

 10/3/2017 LUCAS A. TURNER, P.E. FL PE #58201 TURNER ENGINEERING & CONSULTING, INC. FBPE C.O.A. #29779 Ph. 941-380-1574 6200 JARAWA AVE., NORTH PORT, FL 34208	SCALE: 0.75:1 SHEET: 4 of 8 SERIES: ALL MULLED PRODUCTS TITLE: REINFORCED VINYL MULLIONS	SIZE: C DRAWING NUMBER: RM0015B REV: 7 DRAWN BY: RTW DATE: 3-20-06 CHECKED BY: TDD DATE: 12/18/08 APPROVED BY: CAP DATE: 01/20/12
---	---	---

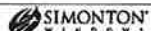

COCHRANE AVE, PENNSBORO, WV 26415  
PH, 800-426-2249

EXTRUDED NON-IMPACT VINYL MULLIONS  
WITH ALUMINUM REINFORCEMENT  
ALL NON-IMPACT WINDOW SERIES

REVISIONS			
REV.	DESCRIPTION	DATE	BY
3	Revised per 2007 Florida Building Code, Added Sheet 8.	04/15/2011	JRM
4	Revised per 2010 Florida Building Code, updated general notes sht.1.	01/20/2012	CAP
5	Updated DP ratings chart and added new mullion covers.	06/20/2012	T.J.D.
6	Revised per 5th Ed. (2014) FBC	04/25/2015	IAT
7	Updated Note 1, Sheet 1	10/03/2017	LMH

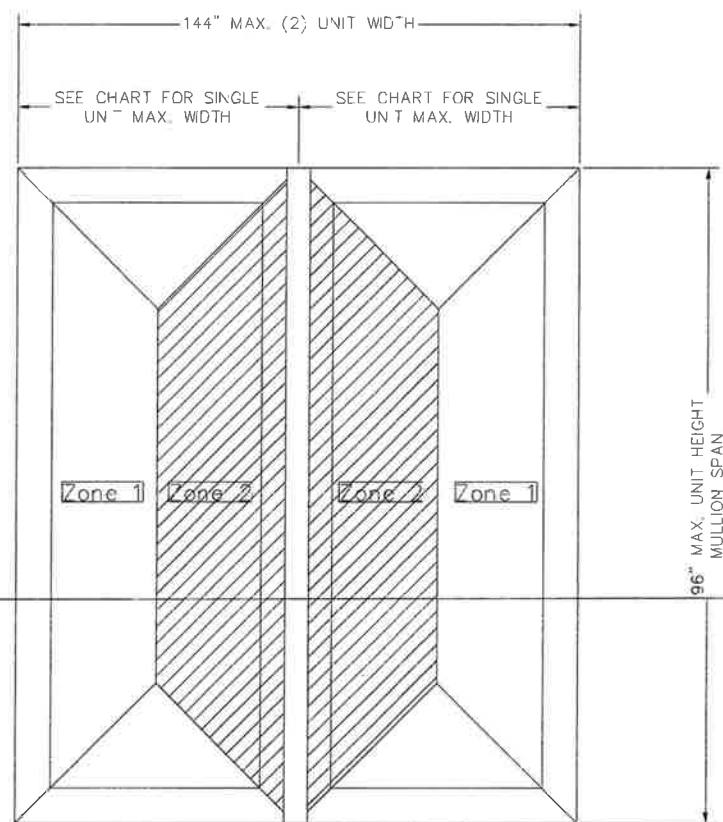
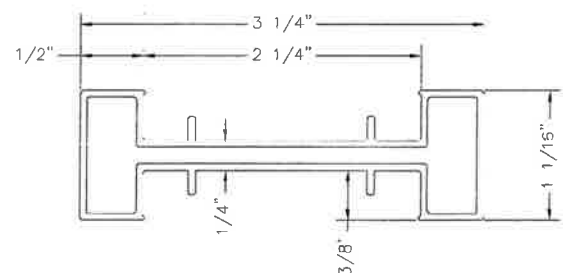
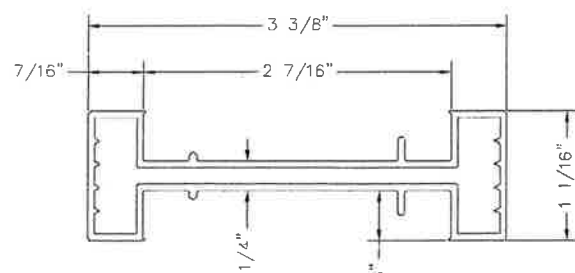

TABLE B - MAXIMUM DESIGN PRESSURES (PSF)  
MULLION #16991

Mullion Length	Individual Unit Width												
	24	28	32	36	40	44	48	52	56	60	64	68	72
40	75	75	75	75	75	75	75	75	75	75	75	75	75
44	75	75	75	75	75	75	75	75	75	75	75	75	75
48	75	75	75	75	75	75	75	75	75	75	75	75	75
52	75	75	75	75	75	75	75	75	75	75	75	75	75
56	75	75	75	75	75	75	70	70	70	70	70	70	70
60	75	75	75	75	70	65	65	65	60	60	60	60	60
64	75	75	70	65	65	60	55	55	55	55	55	55	55
68	75	75	65	60	55	55	50	50	50	50	45	45	45
72	75	70	60	55	55	50	45	45	45	45	40	40	40
76	70	65	55	50	50	45	45	40	40	40	40	40	35
80	65	60	55	50	45	40	40	40	35	35	35	35	35
84	65	55	50	45	40	40	35	35	35	35	30	30	30
88	60	55	45	45	40	35	35	35	30	30	30	30	30
92	55	50	45	40	35	35	35	30	30	30	25	25	25
96	55	45	40	40	35	35	30	30	30	25	25	25	25



PROFINISH H-MULLION  
LARGE VINYL MULLION COVER #VPI-560  
EXTRUDED VINYL .079" MIN.



RETROFIT H-MULLION  
LARGE VINYL MULLION COVER #VPI-354  
EXTRUDED VINYL .071" MIN.

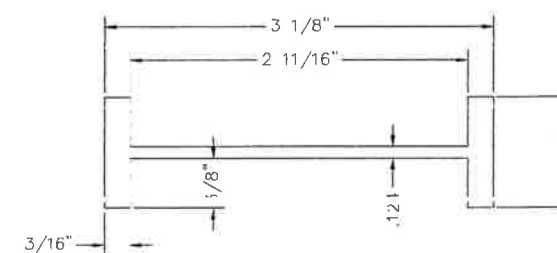

LARGE MULL REINFORCEMENT #16991  
ALUMINUM 6063-T6

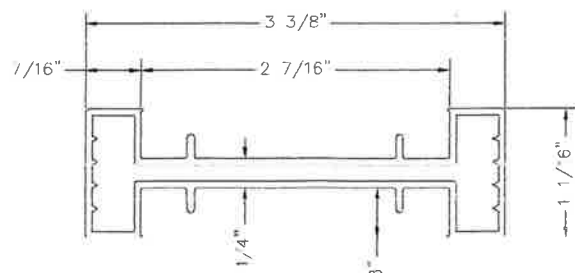

4000 SERIES RETROFIT H-MULLION  
LARGE VINYL MULLION COVER #VPI-354  
EXTRUDED VINYL .071" MIN.



MAXIMUM SINGLE WINDOW WIDTH

WINDOW TYPE	WINDOW WIDTH
SINGLE HUNG	52"
DOUBLE HUNG	56"
HORIZONTAL SLIDER	72"
CASEMENT	36"
FIXED	96"

MULLION TRIJUTARY WIDTH = SUM  
OF ZONE 2 WINDOW WIDTHS

SEE NOTES SHEETS 6, 7, AND 8 FOR REQUIRED ANCHORAGE INFORMATION.

ZZ  
10/3/2017

LUCAS A. TURNER, S.E. (FL PE #58201)  
TURNER ENGINEERING & CONSULTING, INC.  
1239 JABARA AVE., NORTH PORT, FL 34288

SIMANTON WINDOWS  
SERIES: ALL MILLED PRODUCTS  
TYPE: REINFORCED VINYL MULLIONS

SCALE: C.75:1 SHEET 3 of 8  
DRAWN BY: R.T.W. DATE: 3-20-06  
CHECKED BY: TOD. DATE: 12/18/06  
APPROVED BY: CAP. DATE: 01/20/12

DRAWING NUMBER: RM0015B  
REV: 7



**SIMONTON**  
WINDOWS  
1 COCHRANE AVE. PENNSBORO, WV 26413  
PH. 800-426-2249

EXTRUDED NON-IMPACT VINYL MULLIONS  
WITH ALUMINUM REINFORCEMENT  
ALL NON-IMPACT WINDOW SERIES

REVISIONS			
REV.	DESCRIPTION	DATE	BY
3	Revised per 2007 Florida Building Code, Added Sheet 8.	04/15/2011	JRM
4	Revised per 2010 Florida Building Code, updated general notes sht.1.	01/20/2012	CAP
5	Updated DP ratings chart and added new mullion covers.	06/20/2012	T.D.D.
6	Revised per 5th Ed. (2014) FBC	04/25/2015	LAT
7	Updated Note 1, Sheet 1	10/03/2017	LMH

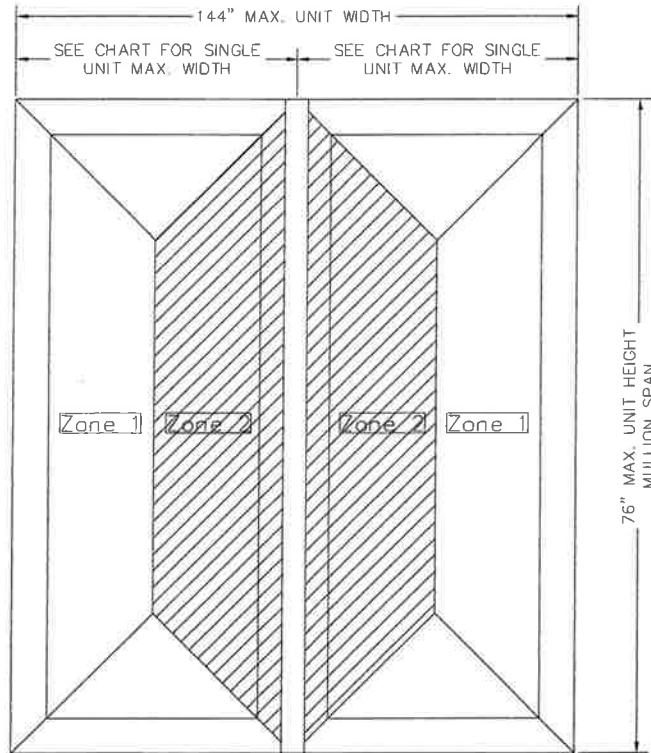

TABLE A - MAXIMUM DESIGN PRESSURES (PSF)  
MULLION # CM0146

Mullion Length	Individual Unit Width												
	24	28	32	36	40	44	48	52	56	60	64	68	72
40	75	75	75	75	75	75	75	75	75	75	75	75	75
44	75	75	75	75	75	75	75	75	75	75	75	75	75
48	75	75	75	75	75	75	75	75	75	75	75	75	75
52	75	75	75	75	75	75	75	75	75	75	75	75	75
56	75	75	75	75	75	75	70	70	70	70	70	70	70
60	75	75	75	75	70	65	65	60	60	60	60	60	60
64	75	75	70	65	65	60	55	55	55	55	55	55	55
68	75	75	65	60	55	55	50	50	50	50	45	45	45
72	75	70	60	55	55	50	45	45	45	45	40	40	40
76	70	65	55	50	50	45	45	40	40	40	40	40	35
80	65	60	55	50	45	40	40	35	35	35	35	35	35
84	65	55	50	45	40	40	35	35	35	30	30	30	30
88	60	55	45	45	40	35	35	35	30	30	30	30	30
92	55	50	45	40	35	35	35	30	30	30	25	25	25
96	55	45	40	40	35	35	30	30	30	25	25	25	25

MAXIMUM SINGLE WINDOW WIDTH

WINDOW TYPE	WINDOW WIDTH
DOUBLE HUNG	56"
HORIZONTAL SLIDER	72"
CASEMENT	36"
FIXED	96"

MULLION TRIBUTARY WIDTH = SUM OF ZONE 2 WINDOW WIDTHS

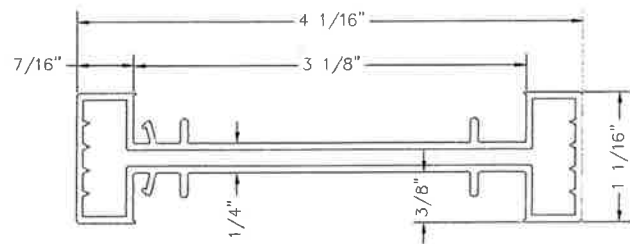

ALL FIN & J FRAMES H-MULLION  
LARGE VINYL MULLION COVER #VPI-573  
EXTRUDED VINYL .071" MIN.

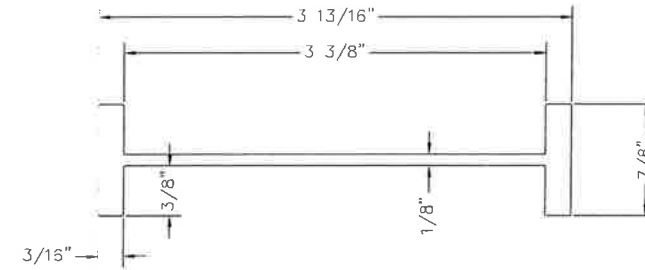

LARGE MULL REINFORCEMENT #CM0146  
ALUMINUM 6063-T6



SEE NOTES SHEETS 6, 7, AND 8 FOR REQUIRED ANCHORAGE INFORMATION.

10/3/2017

**SIMONTON** WINDOWS

SCALE: 0.75:1 SHEET 2 of 8

SERIES: ALL MULL PRODUCTS

TITLE: REINFORCED VINYL MULLIONS

DATE: 3-20-08	DATE: 12/18/08	DATE: 01/20/12
DRAWN BY: RTW	CHECKED BY: TOD	APPROVED BY: CAP
DRAWING NUMBER: RM0015B1	REV: 7	



**SIMONTON**  
WINDOWS  
1 COCHRAN AVE PENNSBORO, WV 26415  
PH. 800-426-2249

EXTRUDED NON-IMPACT VINYL MULLIONS  
WITH ALUMINUM REINFORCEMENT  
ALL NON-IMPACT WINDOW SERIES

MULLIONS MEET THE REQUIREMENTS OF THE CURRENT  
FLORIDA BUILDING CODE.

REVISIONS			
REV.	DESCRIPTION	DATE	BY
3	Revised per 2007 Florida Building Code, Added Sheet 8.	04/15/2011	JRM
4	Revised per 2010 Florida Building Code, updated general notes sht.1.	01/20/2012	CAP
5	Updated DP ratings chart and added new mullion covers.	06/20/2012	T.C.D.
6	Revised per 5th Ed. (2014) FBC	04/25/2015	LAT
7	Updated Note 1, Sheet 1	10/03/2017	LMH

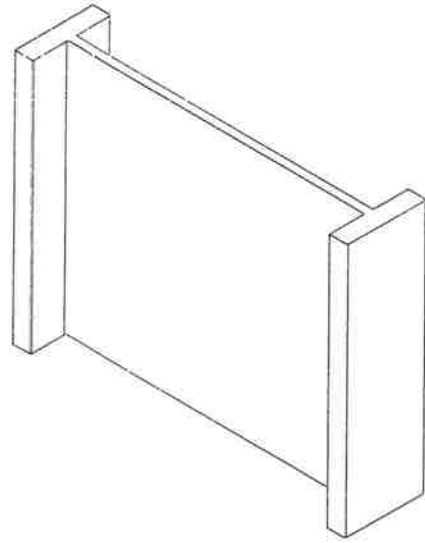

LARGE MULLION  
REINFORCEMENT CM0146  
ALUMINUM 6063-T6

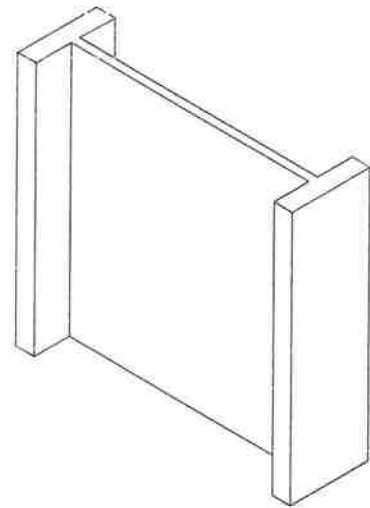

LARGE MULLION  
REINFORCEMENT #16991  
ALUMINUM 6063-T6

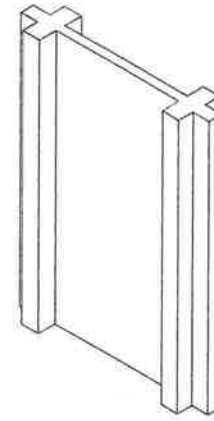

MEDIUM MULLION  
REINFORCEMENT #16990  
ALUMINUM 6063-T6

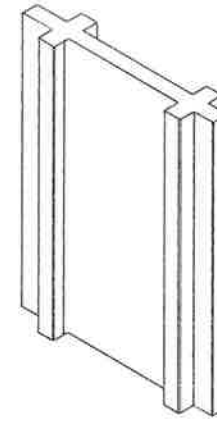

MEDIUM MULLION  
REINFORCEMENT #20634  
ALUMINUM 6063-T6

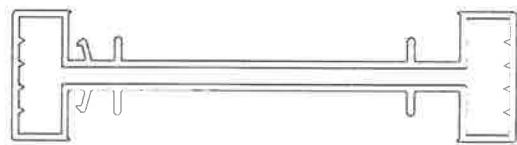

5000 FIN & J FRAME VINYL  
H-MULLION COVER #VPI 573  
EXTRUDED VINYL 0.071" MIN.

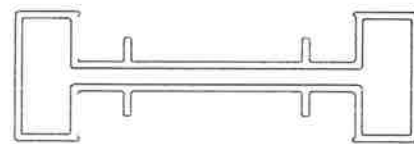

PRO-FINISH LARGE VINYL  
H-MULLION COVER #VPI-560  
EXTRUDED VINYL 0.079" MIN.

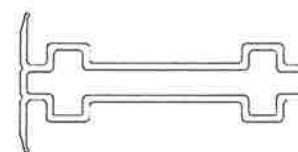

PRO-FINISH MEDIUM VINYL  
H-MULLION COVER #VPI 346A  
EXTRUDED VINYL 0.071" MIN.

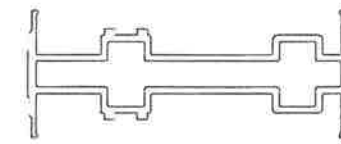

RETROFIT MEDIUM VINYL  
H-MULLION COVER #VPI-136  
EXTRUDED VINYL 0.070" MIN.

PRODUCT DESCRIPTION:

1. ALL MULLION REINFORCEMENTS ARE EXTRUDED ALUMINUM 6063-T6.
2. ALL MULLION COVERS ARE EXTRUDED VINYL. SEE ABOVE FOR INDIVIDUAL MULLION THICKNESS.

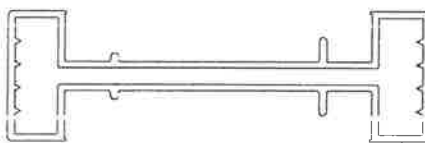

RETROFIT LARGE VINYL  
H-MULLION COVER #VPI-354  
EXTRUDED VINYL 0.071" MIN.

Lucas  
Turner  
2017-10-18  
11:15+20:00

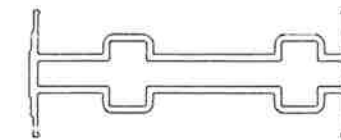

4000 SERIES MEDIUM VINYL  
H-MULLION COVER #MPO347  
EXTRUDED VINYL 0.070" MIN.

TABLE OF CONTENTS	
SHEET	DESCRIPTION
1	INDIVIDUAL MULLION APPLICATIONS
2	DESIGN PRESSURES FOR REINFORCEMENT CM0146
3	DESIGN PRESSURES FOR REINFORCEMENT 16991
4	DESIGN PRESSURES FOR REINFORCEMENT 16990
5	DESIGN PRESSURES FOR REINFORCEMENT 20634
6	MULLION ATTACHMENT AND ANCHORING
7	MULLION CROSS SECTIONS-MOOD FRAME SUBSTRATE
8	MULLION CROSS SECTIONS-MASONRY/CONC. SUBSTRATE

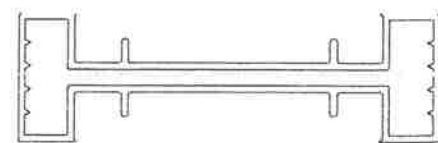

4000 SERIES LARGE VINYL  
H-MULLION COVER #VPI-354A  
EXTRUDED VINYL 0.071" MIN.

GENERAL NOTES:

1. THE FOUR (4) MULLION PRODUCTS MEET THE CURRENT FLORIDA BUILDING CODE SECTION 1709.8, INCLUDING L/175 DEFLECTION LIMIT, LOAD TRANSFER, AND FIBERSTRESS ANALYSES IN THE DESIGN PRESSURES SHOWN IN THE TABLES IN THIS DRAWING. THE ANALYSES DID NOT ADDRESS AIR OR WATER INFILTRATION. OVERALL WINDOW ASSEMBLY ALLOWABLE DESIGN PRESSURES SHALL BE THE LOWER OF THE MULLION PER THIS APPROVAL OR THE SIMONTON WINDOWS PER SEPARATE PRODUCT APPROVAL.
2. PRODUCT ANCHORS SHALL BE AS LISTED AND SPACED AS SHOWN HEREIN.

22	10/3/2017	SICAL C.75"	SHEET: 1 of 8	APPROVED BY:	DATE:
				CAP	10/20/12
LUCAS A. TURNER, P.E. FL PE #58201 TURNER ENGINEERING & CONSULTING, INC. 1239 JABARA AVE, NORTH PORT, FL 34288		SHEET: 1 of 8		DATE: 10/20/12	
TITLE: REINFORCED VINYL MULLIONS		DRAWING NUMBER: REV. 7			



[BCIS Home](#)
[Log In](#)
[User Registration](#)
[Hot Topics](#)
[Submit Surcharge](#)
[Stats & Facts](#)
[Publications](#)
[FBC Staff](#)
[BCIS Site Map](#)
[Links](#)
[Search](#)



**Product Approval**  
USER: Public User

[Product Approval Menu](#) > 
 [Product or Application Search](#) > 
 [Application List](#) > 
 **Application Detail**

OFFICE OF THE SECRETARY

FL # FL7612-R17  
 Application Type Revision  
 Code Version 2017  
 Application Status Approved  
 \*Approved by DBPR. Approvals by DBPR shall be reviewed and ratified by the POC and/or the Commission if necessary.

Comments  
 Archived

Product Manufacturer Simonton/Ply Gem Windows  
 Address/Phone/Email 3948 Townsfair Way, Suite 200  
 Suite 200  
 Columbus, OH 43219  
 (614) 532-3596  
 luanne.harris@plygem.com

Authorized Signature Luanne Harris  
 luanne.harris@plygem.com

Technical Representative Luanne Harris  
 Address/Phone/Email 3948 Townsfair Way  
 Suite 200  
 Columbus, OH 43219  
 (614) 532-3596  
 luanne.harris@simonton.com

Quality Assurance Representative AAMA  
 Address/Phone/Email 1827 Walden Office Square  
 Suite 550  
 Schaumburg, IL 60173  
 (847) 303-5664  
 webmaster@aamanet.org

Category Exterior Doors  
 Subcategory Sliding Exterior Door Assemblies

Compliance Method Certification Mark or Listing

Certification Agency American Architectural Manufacturers Association  
 Validated By American Architectural Manufacturers Association

Referenced Standard and Year (of Standard)	Standard	Year
	AAMA 450	2010
	AAMA/WDMA/CSA 101/I.S.2/A440	2008

Equivalence of Product Standards Certified By  
 Florida Licensed Professional Engineer or Architect  
[FL7612\\_R17\\_Equiv\\_EvalReport-IN0444-R7.pdf](#)

Product Approval Method Method 1 Option A

Date Submitted 11/15/2017

Date Validated 12/05/2017

Date Pending FBC Approval

Date Approved 12/07/2017

**Summary of Products**

FL #	Model, Number or Name	Description
7612.1	06-05	ProFinish Contractor, ProFinish Master, PerfeXion Contractor 2-Lite Sliding Patio Door
<b>Limits of Use</b> Approved for use in HVHZ: No Approved for use outside HVHZ: Yes Impact Resistant: No Design Pressure: N/A Other: 77x84 (+/-30 PSF), 71x80 (+/-35 PSF), 71x96 (+/-35 PSF), 95x80 (+/-35 PSF), 71x80 (+/-50 PSF)		<b>Certification Agency Certificate</b> <a href="#">FL7612 R17 C CAC 06-05 2P SGD (Fin) 71x80 R-PG50.pdf</a> <a href="#">FL7612 R17 C CAC 06-05 2P SGD (Fin) 71x80 R-PG35.pdf</a> <a href="#">FL7612 R17 C CAC 06-05 2P SGD (Fin) 71x96 R-PG35.pdf</a> <a href="#">FL7612 R17 C CAC 06-05 2P SGD (Fin) 95x80 R35.pdf</a> <a href="#">FL7612 R17 C CAC 06-05 2P SGD (Finless) 71x80 R-PG35.pdf</a> <a href="#">FL7612 R17 C CAC 06-05 2P SGD (Finless) 71x80 R-PG50.pdf</a> <a href="#">FL7612 R17 C CAC 06-05 2P SGD (Finless) 71x96 R-PG35.pdf</a> <a href="#">FL7612 R17 C CAC 06-05 2P SGD (Finless) 95x80 R35.pdf</a> <a href="#">FL7612 R17 C CAC 06-05 2PSGD (Fin) 77x84 R-PG30.pdf</a> <b>Quality Assurance Contract Expiration Date</b> 10/31/2021 <b>Installation Instructions</b> <a href="#">FL7612 R17 II IN0340 06-05 2P PD 2X.pdf</a> <a href="#">FL7612 R17 II IN0444-R7 06-05 2P 1X.pdf</a> Verified By: American Architectural Manufacturers Association Created by Independent Third Party: <b>Evaluation Reports</b> <a href="#">FL7612 R17 AE EvalReport-IN0444-R7.pdf</a> Created by Independent Third Party: Yes
7612.2	06-05	ProFinish Contractor, ProFinish Master, PerfeXion Contractor Vinyl 3-Lite Sliding Patio Door
<b>Limits of Use</b> Approved for use in HVHZ: No Approved for use outside HVHZ: Yes Impact Resistant: No Design Pressure: N/A Other: 107x80 (+/-30 PSF), 107x80 (+/-45 PSF)		<b>Certification Agency Certificate</b> <a href="#">FL7612 R17 C CAC 06-05 3P SGD (Fin) 107x80 R-PG30.pdf</a> <a href="#">FL7612 R17 C CAC 06-05 3P SGD (Fin) 107x80 R-PG45.pdf</a> <b>Quality Assurance Contract Expiration Date</b> 11/20/2022 <b>Installation Instructions</b> <a href="#">FL7612 R17 II IN0341 06-05 3P PD 2X.pdf</a> <a href="#">FL7612 R17 II IN0445-R4 06-05 3P PD 1X.pdf</a> Verified By: American Architectural Manufacturers Association Created by Independent Third Party: <b>Evaluation Reports</b> <a href="#">FL7612 R17 AE EvalReport-IN0445-R4.pdf</a> Created by Independent Third Party: Yes
7612.3	06-05	Reflections 5300, 6100 VantagePointe Vinyl 2-Lite Sliding Patio Door with Transom (Retrofit Installation)
<b>Limits of Use</b> Approved for use in HVHZ: No Approved for use outside HVHZ: Yes Impact Resistant: No Design Pressure: +45/-45 Other: 71x116 Retrofit Installation		<b>Certification Agency Certificate</b> <a href="#">FL7612 R17 C CAC 06-05 2P SGD w Transom (Finless) 71x116 R45.pdf</a> <b>Quality Assurance Contract Expiration Date</b> 01/29/2022 <b>Installation Instructions</b> <a href="#">FL7612 R17 II IN0413 06-05 2PD w Transom 2X.pdf</a> Verified By: American Architectural Manufacturers Association Created by Independent Third Party: <b>Evaluation Reports</b> Created by Independent Third Party:
7612.4	06-05	Reflections 5300, 6100 VantagePointe Vinyl 2-Lite Sliding Patio Door (Retrofit Installation)
<b>Limits of Use</b> Approved for use in HVHZ: No Approved for use outside HVHZ: Yes		<b>Certification Agency Certificate</b> <a href="#">FL7612 R17 C CAC 06-05 2P SGD (Finless) 71x80 R-PG35.pdf</a>

<p><b>Impact Resistant:</b> No  <b>Design Pressure:</b> N/A  <b>Other:</b> 95x80 (+/-35 PSF), 71x96 (+/-35 PSF), 71x80 (+/-35 PSF), 71x80 (+/-50 PSF) Retrofit Installation</p>		<p><a href="#">FL7612 R17 C CAC 06-05 2P SGD (Finless) 71x80 R PG50.pdf</a>  <a href="#">FL7612 R17 C CAC 06-05 2P SGD (Finless) 71x96 R PG35.pdf</a>  <a href="#">FL7612 R17 C CAC 06-05 2P SGD (Finless) 95x80 R35.pdf</a>  <b>Quality Assurance Contract Expiration Date</b>                      01/29/2022  <b>Installation Instructions</b>  <a href="#">FL7612 R17 II IN0412 06-05 2P PD 2X.pdf</a>                      Verified By: American Architectural Manufacturers Association                      Created by Independent Third Party:  <b>Evaluation Reports</b>                      Created by Independent Third Party:</p>
<p>7612.5</p>	<p>15-15</p>	<p>Inovo, 6500 VantagePointe 2-Lite Sliding Patio Door (Retrofit Installation)</p>
<p><b>Limits of Use</b>  <b>Approved for use in HVHZ:</b> No  <b>Approved for use outside HVHZ:</b> Yes  <b>Impact Resistant:</b> No  <b>Design Pressure:</b> N/A  <b>Other:</b> 71x81 (+/-35), 71x81 (+/-50 PSF), 95x95 (+/-35) Retrofit Installation</p>		<p><b>Certification Agency Certificate</b>  <a href="#">FL7612 R17 C CAC 15-15 2P SGD 71x81 R-PG35 (Finless).pdf</a>  <a href="#">FL7612 R17 C CAC 15-15 2P SGD 71x81 R-PG50 (Finless).pdf</a>  <a href="#">FL7612 R17 C CAC 15-15 2P SGD 95x95 R PG35 (finless).pdf</a>  <b>Quality Assurance Contract Expiration Date</b>                      09/14/2020  <b>Installation Instructions</b>  <a href="#">FL7612 R17 II IN0573-R2 15-15 2P PD.pdf</a>                      Verified By: American Architectural Manufacturers Association                      Created by Independent Third Party:  <b>Evaluation Reports</b>  <a href="#">FL7612 R17 AE EvalReport-IN0573-R2.pdf</a>                      Created by Independent Third Party: Yes</p>
<p>7612.6</p>	<p>15-15</p>	<p>Inovo, VantagePointe 6500 3-Lite Sliding Patio Door (Retrofit Installation)</p>
<p><b>Limits of Use</b>  <b>Approved for use in HVHZ:</b> No  <b>Approved for use outside HVHZ:</b> Yes  <b>Impact Resistant:</b> No  <b>Design Pressure:</b> +35/-35  <b>Other:</b> 107x79</p>		<p><b>Certification Agency Certificate</b>  <a href="#">FL7612 R17 C CAC 15-15 3P SGD 107x79 R-PG35 (Finless).pdf</a>  <b>Quality Assurance Contract Expiration Date</b>                      09/14/2020  <b>Installation Instructions</b>  <a href="#">FL7612 R17 II IN0581-R1 15-15 3P PD.pdf</a>                      Verified By: American Architectural Manufacturers Association                      Created by Independent Third Party:  <b>Evaluation Reports</b>  <a href="#">FL7612 R17 AE EvalReport-IN0581-R1.pdf</a>                      Created by Independent Third Party: Yes</p>
<p>7612.7</p>	<p>15-15</p>	<p>Inovo, VantagePointe 6500 4-Lite Sliding Patio Door (Retrofit Installation)</p>
<p><b>Limits of Use</b>  <b>Approved for use in HVHZ:</b> No  <b>Approved for use outside HVHZ:</b> Yes  <b>Impact Resistant:</b> No  <b>Design Pressure:</b> +25/-25  <b>Other:</b> 143x79</p>		<p><b>Certification Agency Certificate</b>  <a href="#">FL7612 R17 C CAC 15-15 4P SGD 143x79 R PG25 (finless).pdf</a>  <b>Quality Assurance Contract Expiration Date</b>                      07/16/2020  <b>Installation Instructions</b>  <a href="#">FL7612 R17 II IN0583-R1 15-15 4P PD.pdf</a>                      Verified By: American Architectural Manufacturers Association                      Created by Independent Third Party:  <b>Evaluation Reports</b>  <a href="#">FL7612 R17 AE EvalReport-IN0583-R1.pdf</a>                      Created by Independent Third Party: Yes</p>
<p>7612.8</p>	<p>15-16</p>	<p>Inovo, 6500 VantagePointe 2-Lite Sliding Patio Door</p>
<p><b>Limits of Use</b>  <b>Approved for use in HVHZ:</b> No  <b>Approved for use outside HVHZ:</b> Yes  <b>Impact Resistant:</b> No  <b>Design Pressure:</b> N/A  <b>Other:</b> 71x81 (+/-20 PSF), 71x81 (+/-35 PSF), 71x81 (+/-50 PSF), 95x79 (+/-35), 95x95 (+/-35)</p>		<p><b>Certification Agency Certificate</b>  <a href="#">FL7612 R17 C CAC 15-16 2P SGD 71x81 R PG20 (NO WEEP HOLES).pdf</a>  <a href="#">FL7612 R17 C CAC 15-16 2P SGD 71x81 R PG35.pdf</a>  <a href="#">FL7612 R17 C CAC 15-16 2P SGD 71x81 R-PG50.pdf</a>  <a href="#">FL7612 R17 C CAC 15-16 2P SGD 95x79 R PG35.pdf</a>  <a href="#">FL7612 R17 C CAC 15-16 2P SGD 95x95 R PG35.pdf</a>  <b>Quality Assurance Contract Expiration Date</b>                      06/04/2020  <b>Installation Instructions</b>  <a href="#">FL7612 R17 II IN0571 15-16 2P PD 2X.pdf</a>                      Verified By: American Architectural Manufacturers</p>

		Association Created by Independent Third Party: <b>Evaluation Reports</b> Created by Independent Third Party:
7612.9	15-16	Inovo, 6500 VantagePointe 3-Lite Sliding Patio Door
<b>Limits of Use</b> <b>Approved for use in HVHZ:</b> No <b>Approved for use outside HVHZ:</b> Yes <b>Impact Resistant:</b> No <b>Design Pressure:</b> +35/-35 <b>Other:</b> 107x79		<b>Certification Agency Certificate</b> <a href="#">FL7612_R17_C_CAC_15-16_3P_SGD_107x79_R_PG35.pdf</a> <b>Quality Assurance Contract Expiration Date</b> 06/03/2020 <b>Installation Instructions</b> <a href="#">FL7612_R17_IL_IN0576_15-16_3P_PD_2X.pdf</a> Verified By: American Architectural Manufacturers Association Created by Independent Third Party: <b>Evaluation Reports</b> Created by Independent Third Party:

[Back](#) [Next](#)

Contact Us :: [2601 Blair Stone Road, Tallahassee FL 32399 Phone: 850-487-1824](#)

The State of Florida is an AA/EEO employer. [Copyright 2007-2013 State of Florida](#). :: [Privacy Statement](#) :: [Accessibility Statement](#) :: [Refund Statement](#)

Under Florida law, email addresses are public records. If you do not want your e-mail address released in response to a public-records request, do not send electronic mail to this entity. Instead, contact the office by phone or by traditional mail. If you have any questions, please contact 850.487.1395. \*Pursuant to Section 455.275(1), Florida Statutes, effective October 1, 2012, licensees licensed under Chapter 455, F.S. must provide the Department with an email address if they have one. The emails provided may be used for official communication with the licensee. However email addresses are public record. If you do not wish to supply a personal address, please provide the Department with an email address which can be made available to the public. To determine if you are a licensee under Chapter 455, F.S., please click [here](#).



Credit Card  
**Safe**





**MODEL DESIGNATION:** Simonton Series 06-05 2-Panel Vinyl Patio Door

**MAXIMUM OVERALL NOMINAL SIZE:** See Size Chart

**DESIGN PRESSURE RATING:** See Size Chart

**USABLE CONFIGURATIONS:** XO, OX

**GENERAL DESCRIPTION:** The head, sill, and side jambs are extruded PVC. The wall thickness through which the anchor screw penetrates is a minimum of 0.070".

NO P.E. SEAL REQUIRED  
INSTALLATION SUPPORTED  
BY AAMA TEST REPORTS

REV. #:	REVISIONS:	REVISED BY:	DATE:
2	UPDATED NOTES, GENERAL DESCRIPTION, AND ANCHOR LOCATIONS PER NEW TESTING.	T.D.D.	04/06/11
3	ADDED SIZES PER NEW TESTING.	T.D.D.	05/04/11
4	ADDED GLAZING DETAILS.	T.D.D.	06/20/11
5	ADDED GLAZING NOTE AND UPDATED SIZE CHART PER NEW TESTING.	T.D.D.	03/11/13
6	ADDED MIN. EDGE DIST. NOTE	B.J.S.	06/17/15
7	UPDATED SIZE CHART & ANCHOR SPACING	LMH	11/23/15

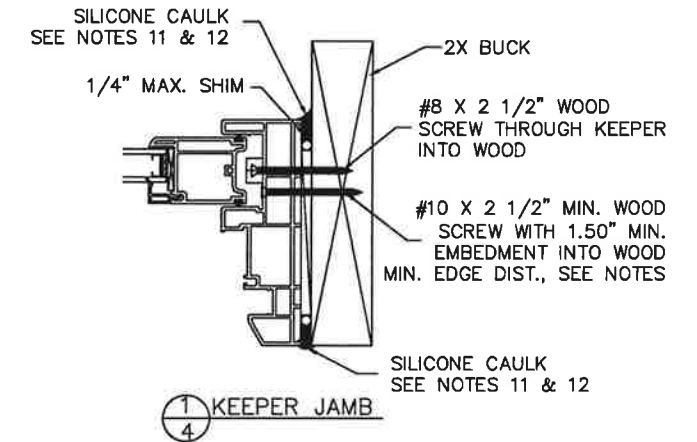
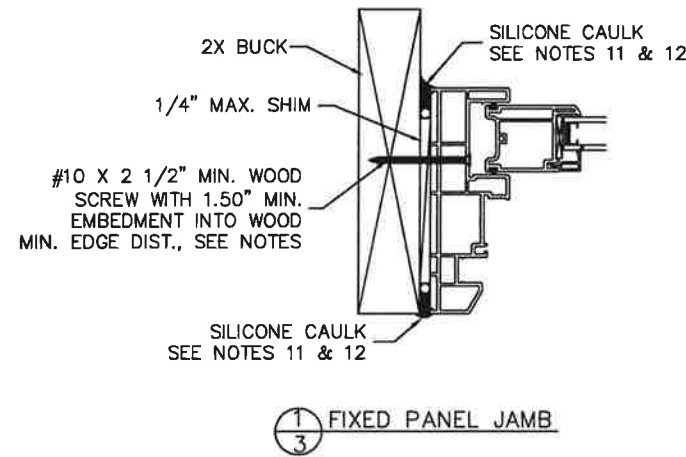
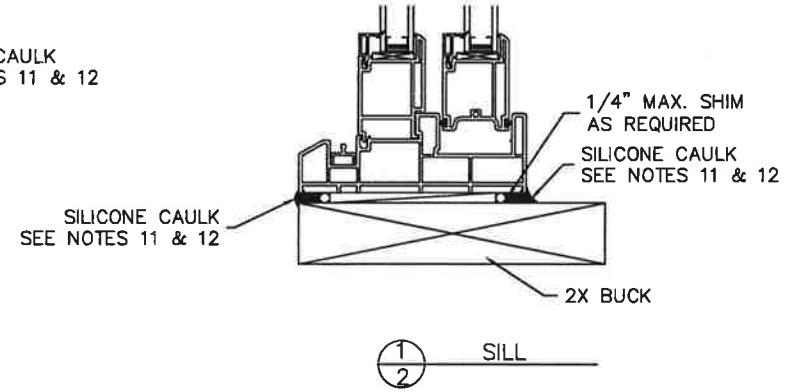
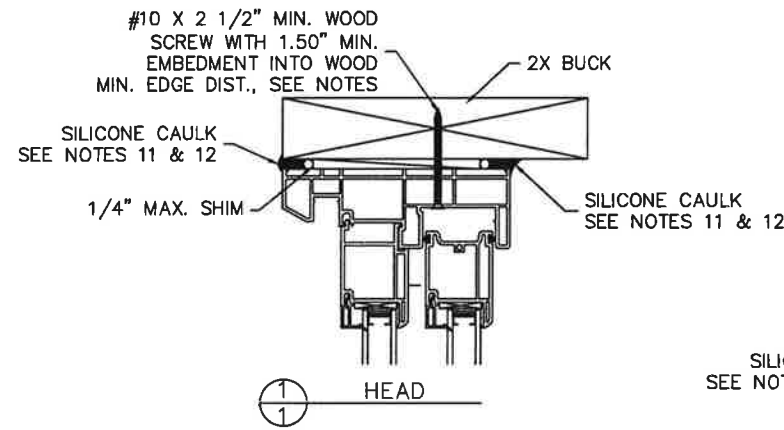
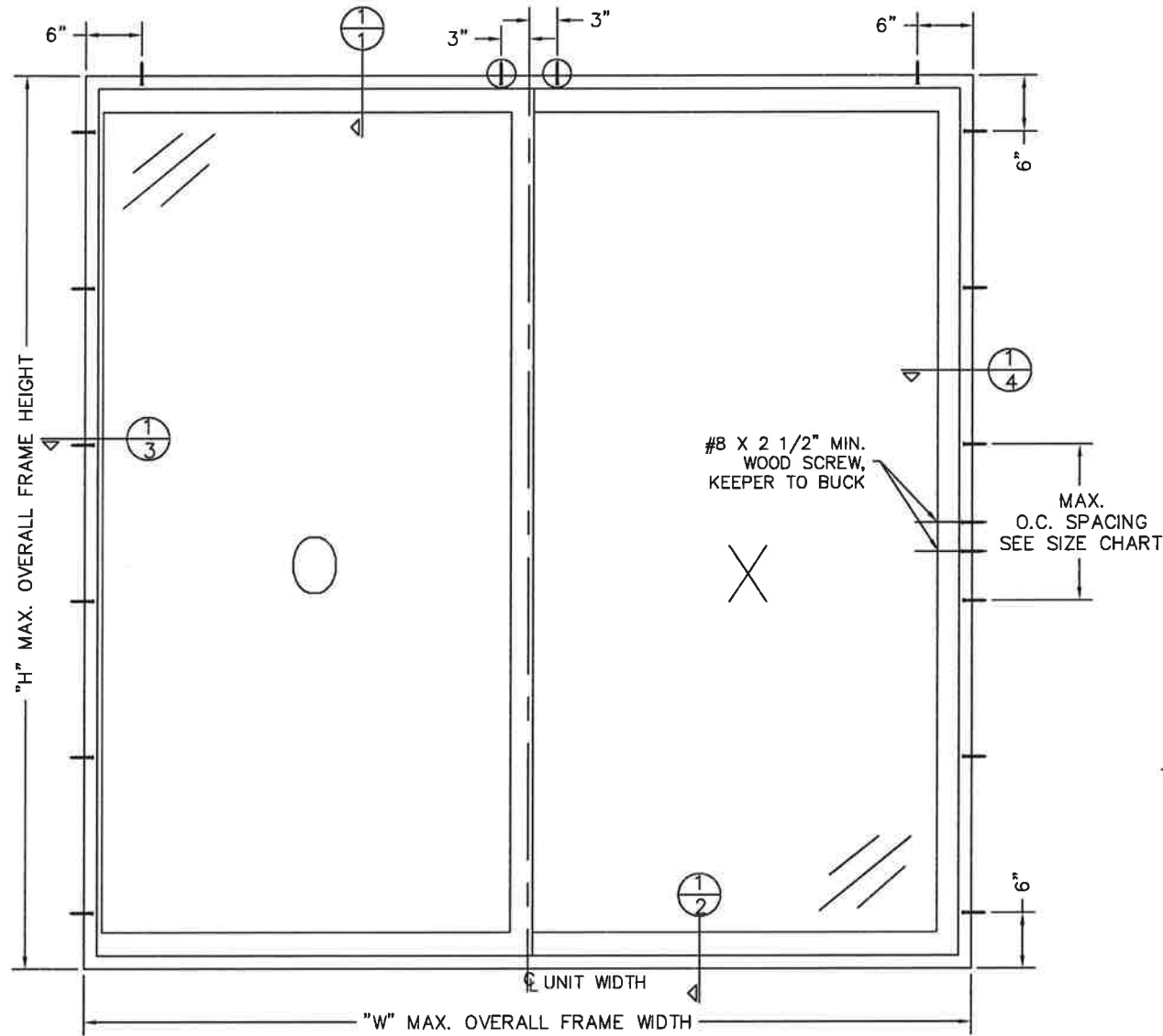

**NOTES:**

1. This installation has been evaluated for use in locations adhering to the Texas & Florida Building Codes and where pressure requirements as determined by ASCE 7 Minimum Design Loads for Buildings and Other Structures do not exceed the design pressure ratings herein, for use outside the H.V.H.Z.
2. All exterior perimeter surfaces of the door must be caulked. Interior caulking is optional unless noted otherwise.
3. Anchors shall be specified and spaced as shown. Anchor embedment to base material shall be beyond wall dressing or stucco and into wood.
4. The responsibility for selection of Simonton products to meet any applicable local laws, building codes, ordinances, or other safety requirements rests solely with the architect, building owner, or contractor.
5. Shims are optional. Maximum shim stack is 1/4".
6. Wood bucks (by others) must be engineered and anchored properly to transfer loads to the structure.
7. When used in areas requiring impact protection, this product **REQUIRES** the use of approved impact resistant shutters or other external protection.
8. Flashing should be applied using the ASTM E 2112 method appropriate for the opening into which the door is being installed.
9. Installation anchors should be at least 3/4" from the edge of the wood.
10. Glazing shall comply with ASTM E 1300 and safety glazing requirements per Florida Building Code section 2406.
11. Use 100% pure silicon caulk. Make sure surfaces are completely free from all old caulk, damaged wood, wood fibers, grease, oil dirt, rust, mold or similar contaminants. Vacuum opening surfaces completely. A fully primed surface is recommended, but not required. Cleaning of all surfaces should be done the same day of which the silicone caulk is to be applied. For more details see "New Construction Installation Instructions" on Simonton.com.
12. Caulk application: recommended air and surface temperatures at the time of application are to be between 40 and 90 degrees F. Insure all contact surfaces are clean and dry including the new window(s). Use a backer rod on all joints >3/4" deep and/or wider than 1/4". Finished caulk joint should be a minimum of 3/8" deep and make full contact with both the new window and structural opening surfaces. Silicone caulk should be forced into joint or compressed to assure full contact on both surfaces and to expel any air pockets.

OVERALL SIZE		O.C. SPACING	DP RATING
WIDTH "W"	HEIGHT "H"		
71"	96"	17"	±35 PSF
95"	80"	23"	
71"	80"	23"	±50 PSF
71"	80"	23"	

① CIRCLED ANCHORS REQUIRED ONLY FOR 95x80 AND 71x80-DP35.

**DISCLOSURE STATEMENT**  
This document is the property of Simonton Windows, which retains all proprietary and other rights to its subject matter. This document is provided to the recipient on the expressed condition that it is not to be disclosed, reproduced in whole or part, nor used in conjunction with the design, manufacture or repair of goods for anyone other than Simonton Windows without its consent. This restriction does not limit the recipient's rights to utilize information contained in this document which is properly obtained from another source.

**MATERIAL:**  
RMS FINISH:  
EXCEPT AS NOTED  
ALLOY & TEMPER:  
WEIGHT:  
VOLUME:  
SURFACE AREA:  
PERIMETER:  
FINISH TREATMENT:

**Dimensional Tolerances Unless Otherwise Specified**

Decimals	Angles
.X ± .03	
.XX ± .01	0° 30 min.
.XXX ± .005	

**SIMONTON WINDOWS**  
1 Cochran Avenue  
Pennsboro, WV 26415

SIZE: DRAWING NO.: B IN0412	REV.: 7
DRAWN BY: T.D.D.	DATE: 04/10/09
CHECKED BY:	DATE:
SCALE: FIT	SHEET: 1 of 1
SERIES: 06-05 2-PANEL PATIO DOOR	APPR'VD BY: DATE:
TITLE: 2X BUCK RETROFIT INSTALLATION (AS TESTED)	

FILE: IN0412





[BCIS Home](#) | [Log In](#) | [User Registration](#) | [Hot Topics](#) | [Submit Surcharge](#) | [Stats & Facts](#) | [Publications](#) | [FBC Staff](#) | [BCIS Site Map](#) | [Links](#) | [Search](#)



**Product Approval**  
USER: Public User

[Product Approval Menu](#) > [Product or Application Search](#) > [Application List](#) > [Application Detail](#)

OFFICE OF THE SECRETARY

FL #	FL5167-R26								
Application Type	Revision								
Code Version	2017								
Application Status	Approved								
	*Approved by DBPR. Approvals by DBPR shall be reviewed and ratified by the POC and/or the Commission if necessary.								
Comments									
Archived	<input type="checkbox"/>								
Product Manufacturer	Simonton/Ply Gem Windows								
Address/Phone/Email	3948 Townsfair Way, Suite 200 Suite 200 Columbus, OH 43219 (614) 532-3596 luanne.harris@plygem.com								
Authorized Signature	Luanne Harris luanne.harris@plygem.com								
Technical Representative	Luanne Harris								
Address/Phone/Email	3948 Townsfair Way Suite 200 Columbus, OH 43219 (614) 532-3596 luanne.harris@simonton.com								
Quality Assurance Representative	AAMA								
Address/Phone/Email	1827 Walden Office Square Suite 550 Schaumburg, IL 60173 (847) 303-5664 webmaster@aamanet.org								
Category	Windows								
Subcategory	Double Hung								
Compliance Method	Certification Mark or Listing								
Certification Agency	American Architectural Manufacturers Association								
Validated By	American Architectural Manufacturers Association								
Referenced Standard and Year (of Standard)	<table border="0"> <thead> <tr> <th><u>Standard</u></th> <th><u>Year</u></th> </tr> </thead> <tbody> <tr> <td>AAMA 450</td> <td>2010</td> </tr> <tr> <td>AAMA/WDMA/CSA 101/I.S.2 A440</td> <td>2005</td> </tr> <tr> <td>AAMA/WDMA/CSA 101/I.S.2 A440</td> <td>2008</td> </tr> </tbody> </table>	<u>Standard</u>	<u>Year</u>	AAMA 450	2010	AAMA/WDMA/CSA 101/I.S.2 A440	2005	AAMA/WDMA/CSA 101/I.S.2 A440	2008
<u>Standard</u>	<u>Year</u>								
AAMA 450	2010								
AAMA/WDMA/CSA 101/I.S.2 A440	2005								
AAMA/WDMA/CSA 101/I.S.2 A440	2008								
Equivalence of Product Standards Certified By	Florida Licensed Professional Engineer or Architect <a href="#">FL5167 R26 Equiv EvalReport.pdf</a>								

Product Approval Method Method 1 Option A

Date Submitted 12/01/2017

Date Validated 12/21/2017

Date Pending FBC Approval

Date Approved 12/27/2017

Date Revised 04/13/2018

**Summary of Products**

FL #	Model, Number or Name	Description
5167.1	07-09, 07-10 and 07-20	Reflections 5500, PerfeXion Platinum Vinyl Double Hung
<p><b>Limits of Use</b>  <b>Approved for use in HVHZ:</b> No  <b>Approved for use outside HVHZ:</b> Yes  <b>Impact Resistant:</b> No  <b>Design Pressure:</b> N/A  <b>Other:</b> 48x80 (+/-25 PSF), 56x84 (+/-25 PSF), 53x76 (+/-50 PSF), 36x63 (+/-50 PSF), 44x64 (+/-50 PSF), 47x71 (+/-50 PSF), 37x84 (+/-60 PSF), 37x76 (+/-65 PSF)</p>		<p><b>Certification Agency Certificate</b>  <a href="#">FL5167 R26 C CAC 07-09 DH 36x63 R50.pdf</a>  <a href="#">FL5167 R26 C CAC 07-09 DH 37x76 R PG65.pdf</a>  <a href="#">FL5167 R26 C CAC 07-09 DH 37x84 R PG60.pdf</a>  <a href="#">FL5167 R26 C CAC 07-09 DH 44x63 R50.pdf</a>  <a href="#">FL5167 R26 C CAC 07-09 DH 47x71 R PG50.pdf</a>  <a href="#">FL5167 R26 C CAC 07-09 DH 48x80 R25.pdf</a>  <a href="#">FL5167 R26 C CAC 07-09 DH 53x76 R50.pdf</a>  <a href="#">FL5167 R26 C CAC 07-09 DH 56x84 R PG25.pdf</a>  <a href="#">FL5167 R26 C CAC 07-09-10-20 and 08-09-10-20 Waiver.pdf</a>  <a href="#">FL5167 R26 C CAC 07-75 waiver to 07-09.pdf</a>  <b>Quality Assurance Contract Expiration Date</b>                      04/19/2020  <b>Installation Instructions</b>  <a href="#">FL5167 R26 II IN0066-R11 07-09 07-10 07-20 DH 1X.pdf</a>  <a href="#">FL5167 R26 II IN0067 07-09 07-10 07-20 DH 2X.pdf</a>                      Verified By: American Architectural Manufacturers Association                      Created by Independent Third Party:  <b>Evaluation Reports</b>  <a href="#">FL5167 R26 AE EvalReport-IN0066-R11.pdf</a>                      Created by Independent Third Party: Yes</p>
5167.2	07-09, 07-10 and 07-20	Reflections 5500, PerfeXion Platinum Vinyl Double Hung with Transom
<p><b>Limits of Use</b>  <b>Approved for use in HVHZ:</b> No  <b>Approved for use outside HVHZ:</b> Yes  <b>Impact Resistant:</b> No  <b>Design Pressure:</b> +50/-50  <b>Other:</b> 53x130</p>		<p><b>Certification Agency Certificate</b>  <a href="#">FL5167 R26 C CAC 07-09 DH w Transom 53x130 R PG50.pdf</a>  <a href="#">FL5167 R26 C CAC 07-09-10-20 and 08-09-10-20 Waiver.pdf</a>  <a href="#">FL5167 R26 C CAC 07-75 waiver to 07-09.pdf</a>  <b>Quality Assurance Contract Expiration Date</b>                      04/19/2020  <b>Installation Instructions</b>  <a href="#">FL5167 R26 II IN0063 07-09 07-10 07-20 DH w Transom 2X.pdf</a>                      Verified By: American Architectural Manufacturers Association                      Created by Independent Third Party:  <b>Evaluation Reports</b>                      Created by Independent Third Party:</p>
5167.3	07-09, 07-10 and 07-20	Reflections 5500, PerfeXion Platinum Vinyl Double Hung H-Mulled Triple
<p><b>Limits of Use</b>  <b>Approved for use in HVHZ:</b> No  <b>Approved for use outside HVHZ:</b> Yes  <b>Impact Resistant:</b> No  <b>Design Pressure:</b> +50/-50  <b>Other:</b> 160x76, 126x76</p>		<p><b>Certification Agency Certificate</b>  <a href="#">FL5167 R26 C CAC 07-09 DH Triple 126x76 R PG50.pdf</a>  <a href="#">FL5167 R26 C CAC 07-09 DH Triple 160x76 R PG50.pdf</a>  <a href="#">FL5167 R26 C CAC 07-09-10-20 and 08-09 -10 -20 Waiver.pdf</a>  <a href="#">FL5167 R26 C CAC 07-75 waiver to 07-09.pdf</a>  <b>Quality Assurance Contract Expiration Date</b>                      04/19/2020  <b>Installation Instructions</b>  <a href="#">FL5167 R26 II IN0555 07-09 07-10 07-20 DH Twin-Triple 2X.pdf</a>                      Verified By: American Architectural Manufacturers Association                      Created by Independent Third Party:  <b>Evaluation Reports</b>                      Created by Independent Third Party:</p>
5167.4	07-09, 07-10 and 07-20	

		Reflections 5500, PerfeXion Platinum Vinyl Double Hung Triple with Transom Triple
<b>Limits of Use</b> Approved for use in HVHZ: No Approved for use outside HVHZ: Yes Impact Resistant: No Design Pressure: +35/-35 Other: 109x88		<b>Certification Agency Certificate</b> <a href="#">FL5167 R26 C CAC 07-09 DH Triple w Transom Triple 109x88 R PG35.pdf</a> <a href="#">FL5167 R26 C CAC 07-09-10-20 and 08-09-10-20 Waiver.pdf</a> <a href="#">FL5167 R26 C CAC 07-75 waiver to 07-09.pdf</a> <b>Quality Assurance Contract Expiration Date</b> 12/31/2021 <b>Installation Instructions</b> <a href="#">FL5167 R26 II IN0556 07-09 07-10 07-20 DH Triple w Transom 2X.pdf</a> Verified By: American Architectural Manufacturers Association Created by Independent Third Party: <b>Evaluation Reports</b> Created by Independent Third Party:
5167.5	07-20 (Nailing Fin Installation)	Reflections 5500, PerfeXion Platinum Vinyl Double Hung
<b>Limits of Use</b> Approved for use in HVHZ: No Approved for use outside HVHZ: Yes Impact Resistant: No Design Pressure: N/A Other: 56x84 (+/-25 PSF), 53x76 (+/-50 PSF) & 37x76 (+/-65 PSF)		<b>Certification Agency Certificate</b> <a href="#">FL5167 R26 C CAC 07-20 DH 37x76 R PG65 (ext.).pdf</a> <a href="#">FL5167 R26 C CAC 07-20 DH 53x76 R PG50 (ext.).pdf</a> <a href="#">FL5167 R26 C CAC 07-20 DH 56x84 R PG25 (ext.).pdf</a> <b>Quality Assurance Contract Expiration Date</b> 07/28/2019 <b>Installation Instructions</b> <a href="#">FL5167 R26 II IN0129 07-20 DH 2X.pdf</a> Verified By: American Architectural Manufacturers Association Created by Independent Third Party: <b>Evaluation Reports</b> Created by Independent Third Party:
5167.6	42-19	ProFinish Brickmould 600, PerfeXion BM 600 Vinyl Double Hung
<b>Limits of Use</b> Approved for use in HVHZ: No Approved for use outside HVHZ: Yes Impact Resistant: No Design Pressure: N/A Other: 52x71 (+/-35 PSF), 48x80 (+/-35 PSF), 36x63 (+/-50 PSF), 36x74 (+/-50 PSF)		<b>Certification Agency Certificate</b> <a href="#">FL5167 R26 C CAC 42-19 DH 36x63 R PG50 (ext.).pdf</a> <a href="#">FL5167 R26 C CAC 42-19 DH 36x74 R PG50 (ext.).pdf</a> <a href="#">FL5167 R26 C CAC 42-19 DH 48x80 R PG35 (ext.).pdf</a> <a href="#">FL5167 R26 C CAC 42-19 DH 52x71 R PG35 (ext.).pdf</a> <b>Quality Assurance Contract Expiration Date</b> 09/14/2019 <b>Installation Instructions</b> <a href="#">FL5167 R26 II IN0130-R4 42-19 DH 1X.pdf</a> <a href="#">FL5167 R26 II IN0148 42-19 DH 2X.pdf</a> Verified By: American Architectural Manufacturers Association Created by Independent Third Party: <b>Evaluation Reports</b> <a href="#">FL5167 R26 AE EvalReport-IN0130-R4.pdf</a> Created by Independent Third Party: Yes
5167.7	42-19	ProFinish Brickmould 600, PerfeXion BM 600 Vinyl Double Hung Twin
<b>Limits of Use</b> Approved for use in HVHZ: No Approved for use outside HVHZ: Yes Impact Resistant: No Design Pressure: N/A Other: 89x63 (+/-30 PSF), 97x80 (+/-30 PSF), 73x63 (+/-35), 73x76 (+/-50 PSF)		<b>Certification Agency Certificate</b> <a href="#">FL5167 R26 C CAC 42-19 DH Twin 73x63 R PG35 (ext.).pdf</a> <a href="#">FL5167 R26 C CAC 42-19 DH Twin 73x76 R PG50 (ext.).pdf</a> <a href="#">FL5167 R26 C CAC 42-19 DH Twin 89x63 R PG30 (ext.).pdf</a> <a href="#">FL5167 R26 C CAC 42-19 DH Twin 97x80 R PG30 (ext.).pdf</a> <b>Quality Assurance Contract Expiration Date</b> 10/05/2019 <b>Installation Instructions</b> <a href="#">FL5167 R26 II IN0150 42-19 DH Twin 2X.pdf</a> Verified By: American Architectural Manufacturers Association Created by Independent Third Party: <b>Evaluation Reports</b> Created by Independent Third Party:
5167.8	42-19	ProFinish Brickmould 600, PerfeXion BM 600 Vinyl Double Hung Triple
<b>Limits of Use</b> Approved for use in HVHZ: No Approved for use outside HVHZ: Yes Impact Resistant: No		<b>Certification Agency Certificate</b> <a href="#">FL5167 R26 C CAC 42-19 DH Triple 109x74 R PG35 (ext.).pdf</a> <b>Quality Assurance Contract Expiration Date</b>

	<p><b>Design Pressure:</b> +35/-35 <b>Other:</b> 109x74</p>	<p>10/05/2019 <b>Installation Instructions</b> <a href="#">FL5167 R26 II IN0151 42-19 DH Triple 2X.pdf</a> Verified By: American Architectural Manufacturers Association Created by Independent Third Party: <b>Evaluation Reports</b> Created by Independent Third Party:</p>
<p>5167.9</p>	<p>43-17</p>	<p>Profinish Contractor, ProFinish Master, PerfeXion Contractor Vinyl Double Hung</p>
	<p><b>Limits of Use</b> <b>Approved for use in HVHZ:</b> No <b>Approved for use outside HVHZ:</b> Yes <b>Impact Resistant:</b> No <b>Design Pressure:</b> N/A <b>Other:</b> 36x72 (+/-30 PSF), 48x80 (+/-30 PSF), 53x71 (+/-35 PSF), 44x63 (+/-35 PSF), 48x80 (+/-35 PSF), 36x63 (+/-45 PSF), 44x63 (+/-45 PSF), 26x76 (+/-50 PSF) &amp; 36x74 (+/-50 PSF), 32x62 (+/-50 PSF)</p>	<p><b>Certification Agency Certificate</b> <a href="#">FL5167 R26 C CAC 43-17 DH (Fin) 26x76 R50.pdf</a> <a href="#">FL5167 R26 C CAC 43-17 DH (Fin) 44x63 R PG35 (ext.).pdf</a> <a href="#">FL5167 R26 C CAC 43-17 DH (Fin) 48x80 R PG30 (ext.).pdf</a> <a href="#">FL5167 R26 C CAC 43-17 DH (Fin) 48x80 R35.pdf</a> <a href="#">FL5167 R26 C CAC 43-17 DH (Finless) 36x74 R50.pdf</a> <a href="#">FL5167 R26 C CAC 43-17 DH (Finless) 48x80 R35.pdf</a> <a href="#">FL5167 R26 C CAC 43-17 DH 32x62 R50.pdf</a> <a href="#">FL5167 R26 C CAC 43-17 DH 36x63 R PG45.pdf</a> <a href="#">FL5167 R26 C CAC 43-17 DH 36x72 R30 (ext.).pdf</a> <a href="#">FL5167 R26 C CAC 43-17 DH 36x74 R50 (ext.).pdf</a> <a href="#">FL5167 R26 C CAC 43-17 DH 44x63 R45.pdf</a> <a href="#">FL5167 R26 C CAC 43-17 DH 53x71 R35 (Fin) (Ext.).pdf</a> <b>Quality Assurance Contract Expiration Date</b> 10/26/2019 <b>Installation Instructions</b> <a href="#">FL5167 R26 II IN0096 43-17 DH 2X.pdf</a> <a href="#">FL5167 R26 II IN0254-R6 43-17 DH 1X.pdf</a> Verified By: American Architectural Manufacturers Association Created by Independent Third Party: <b>Evaluation Reports</b> <a href="#">FL5167 R26 AE EvalReport-IN0254-R6.pdf</a> Created by Independent Third Party: Yes</p>
<p>5167.10</p>	<p>43-17</p>	<p>Profinish Contractor, ProFinish Master, PerfeXion Contractor Vinyl Double Hung T-mulled Twin</p>
	<p><b>Limits of Use</b> <b>Approved for use in HVHZ:</b> No <b>Approved for use outside HVHZ:</b> Yes <b>Impact Resistant:</b> No <b>Design Pressure:</b> N/A <b>Other:</b> 96x80 (+/-25 PSF), 89x63 (+/-30 PSF), 73x63 (+/-35 PSF) &amp; 72x74 (+/-45 PSF)</p>	<p><b>Certification Agency Certificate</b> <a href="#">FL5167 R26 C CAC 43-17 DH Twin 72x74 R PG45.pdf</a> <a href="#">FL5167 R26 C CAC 43-17 DH Twin 73x63 R PG35.pdf</a> <a href="#">FL5167 R26 C CAC 43-17 DH Twin 89x63 R30.pdf</a> <a href="#">FL5167 R26 C CAC 43-17 DH Twin 96x80 R PG25.pdf</a> <b>Quality Assurance Contract Expiration Date</b> 10/30/2021 <b>Installation Instructions</b> <a href="#">FL5167 R26 II IN0099 43-17 DH Twin 2X.pdf</a> Verified By: American Architectural Manufacturers Association Created by Independent Third Party: <b>Evaluation Reports</b> Created by Independent Third Party:</p>
<p>5167.11</p>	<p>43-35 (Two-Step Sill)</p>	<p>6100 VantagePointe, Asure, PerfeXion Silver Vinyl Double Hung</p>
	<p><b>Limits of Use</b> <b>Approved for use in HVHZ:</b> No <b>Approved for use outside HVHZ:</b> Yes <b>Impact Resistant:</b> No <b>Design Pressure:</b> N/A <b>Other:</b> 44x63 (+/-25 PSF), 46x84 (+/-25 PSF), 36x72 (+/-30 PSF), 48x80 (+/-35 PSF), 52x71 (+/-35 PSF)</p>	<p><b>Certification Agency Certificate</b> <a href="#">FL5167 R26 C CAC 43-35 DH 36x72 R30 (Ext.).pdf</a> <a href="#">FL5167 R26 C CAC 43-35 DH 44x63 R25 (ext.).pdf</a> <a href="#">FL5167 R26 C CAC 43-35 DH 46x84 R25 (ext.).pdf</a> <a href="#">FL5167 R26 C CAC 43-35 DH 48x80 R35 (ext.).pdf</a> <a href="#">FL5167 R26 C CAC 43-35 DH 52x71 R35 (ext.).pdf</a> <b>Quality Assurance Contract Expiration Date</b> 01/24/2021 <b>Installation Instructions</b> <a href="#">FL5167 R26 II IN0105 43-35 DH 2X.pdf</a> <a href="#">FL5167 R26 II IN0568-R3 43-35 DH 1X.pdf</a> Verified By: American Architectural Manufacturers Association Created by Independent Third Party: <b>Evaluation Reports</b> <a href="#">FL5167 R26 AE EvalReport-IN0568-R3.pdf</a> Created by Independent Third Party: Yes</p>
<p>5167.12</p>	<p>43-35 (Two-Step Sill) and 43-50 (Three-Step Sill)</p>	<p>6100 VantagePointe, Asure, PerfeXion Silver Vinyl Double Hung Twin with Transom</p>
	<p><b>Limits of Use</b> <b>Approved for use in HVHZ:</b> No <b>Approved for use outside HVHZ:</b> Yes <b>Impact Resistant:</b> No</p>	<p><b>Certification Agency Certificate</b> <a href="#">FL5167 R26 C CAC 43-35 DH Twin w Transom 73x111 R35 (ext.).pdf</a> <a href="#">FL5167 R26 C CAC 43-50 DH AAMA 450 R35 73x111</a></p>

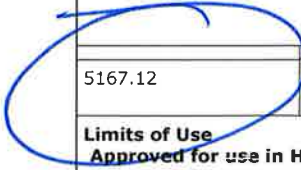



	<p><b>Design Pressure:</b> +35/-35 <b>Other:</b> 73x111</p>	<p><a href="#">(ext.).pdf</a>  <b>Quality Assurance Contract Expiration Date</b>                  01/24/2021  <b>Installation Instructions</b>  <a href="#">FL5167 R26 II IN0535 43-35043-50 DH Twin with Transom 2X.pdf</a>                  Verified By: American Architectural Manufacturers Association                  Created by Independent Third Party:  <b>Evaluation Reports</b>                  Created by Independent Third Party:</p>
<p>5167.13</p>	<p>43-40 and 43-45</p>	<p>Reflections 5050, Reflections 5300, 6100 VantagePointe, PerfeXion Gold Vinyl Double Hung</p>
	<p><b>Limits of Use</b>  <b>Approved for use in HVHZ:</b> No  <b>Approved for use outside HVHZ:</b> Yes  <b>Impact Resistant:</b> No  <b>Design Pressure:</b> N/A  <b>Other:</b> 36x72 (+/-30 PSF), 52x71 (+/-35 PSF), 48x80 (+/-35 PSF), 36x63 (+/-45 PSF), 44x63 (+/-45 PSF), 32x62 (+/-50 PSF), 36x74 (+/-50 PSF)</p>	<p><b>Certification Agency Certificate</b>  <a href="#">FL5167 R26 C CAC 43-40 DH 32x62 R50.pdf</a>  <a href="#">FL5167 R26 C CAC 43-40 DH 36x63 R45.pdf</a>  <a href="#">FL5167 R26 C CAC 43-40 DH 36x72 R30.pdf</a>  <a href="#">FL5167 R26 C CAC 43-40 DH 36x74 R50.pdf</a>  <a href="#">FL5167 R26 C CAC 43-40 DH 44x63 R PG45.pdf</a>  <a href="#">FL5167 R26 C CAC 43-40 DH 44x63 R35.pdf</a>  <a href="#">FL5167 R26 C CAC 43-40 DH 48x80 R35.pdf</a>  <a href="#">FL5167 R26 C CAC 43-40 DH 52x71 R35.pdf</a>  <a href="#">FL5167 R26 C CAC 43-45 DH 52x71 R35.pdf</a>  <a href="#">FL5167 R26 C CAC 43-45 waiver to 43-40.pdf</a>  <b>Quality Assurance Contract Expiration Date</b>                  09/12/2021  <b>Installation Instructions</b>  <a href="#">FL5167 R26 II IN0432b 43-40 43-45 DH 2X.pdf</a>  <a href="#">FL5167 R26 II IN0434-R6 43-40 43-45 DH 1X.pdf</a>                  Verified By: American Architectural Manufacturers Association                  Created by Independent Third Party:  <b>Evaluation Reports</b>  <a href="#">FL5167 R26 AE EvalReport-IN0434-R6.pdf</a>                  Created by Independent Third Party: Yes</p>
<p>5167.14</p>	<p>43-50 (Three-Step Sill)</p>	<p>6100 VantagePointe, Asure, PerfeXion Silver Vinyl Double Hung</p>
	<p><b>Limits of Use</b>  <b>Approved for use in HVHZ:</b> No  <b>Approved for use outside HVHZ:</b> Yes  <b>Impact Resistant:</b> No  <b>Design Pressure:</b> N/A  <b>Other:</b> 52x71 (+/-35 PSF), 36x63 (+/-45 PSF), 44x63 (+/-45 PSF), 32x62 (+/-50 PSF), 36x74 (+/-50 PSF)</p>	<p><b>Certification Agency Certificate</b>  <a href="#">FL5167 R26 C CAC 43-50 DH 32x62 R50 (ext).pdf</a>  <a href="#">FL5167 R26 C CAC 43-50 DH 36x63 R45 (ext).pdf</a>  <a href="#">FL5167 R26 C CAC 43-50 DH 36x74 R50 (ext).pdf</a>  <a href="#">FL5167 R26 C CAC 43-50 DH 44x63 R45 (ext).pdf</a>  <a href="#">FL5167 R26 C CAC 43-50 DH 52x71 R35 (ext).pdf</a>  <b>Quality Assurance Contract Expiration Date</b>                  01/25/2021  <b>Installation Instructions</b>  <a href="#">FL5167 R26 II IN0432 43-50 DH 2X.pdf</a>  <a href="#">FL5167 R26 II IN0569-R3 43-50 DH 1X.pdf</a>                  Verified By: American Architectural Manufacturers Association                  Created by Independent Third Party:  <b>Evaluation Reports</b>  <a href="#">FL5167 R26 AE EvalReport-IN0569-R3.pdf</a>                  Created by Independent Third Party: Yes</p>
<p>5167.15</p>	<p>75-75, 75-09, 07-75, 07-09, 07-10 and 07-20</p>	<p>Reflections 5500, Generations, Impressions 9800, 6500 VantagePointe, PerfeXion Platinum Vinyl Double Hung</p>
	<p><b>Limits of Use</b>  <b>Approved for use in HVHZ:</b> No  <b>Approved for use outside HVHZ:</b> Yes  <b>Impact Resistant:</b> No  <b>Design Pressure:</b> N/A  <b>Other:</b> 48x80 (+/-25 PSF), 53x74 (+/-30 PSF), 48x80 (+/-35 PSF), 52x71 (+/-35 PSF), 53x80 (+/-40 PSF), 36x63 (+/-50 PSF), 36x74 (+/-50 PSF)</p>	<p><b>Certification Agency Certificate</b>  <a href="#">FL5167 R26 C CAC 07-09-10-20 and 08-09-10-20 Waiver.pdf</a>  <a href="#">FL5167 R26 C CAC 07-10 07-20 to 07-09 Waiver.pdf</a>  <a href="#">FL5167 R26 C CAC 07-75 DH 48x80 R PG35.pdf</a>  <a href="#">FL5167 R26 C CAC 07-75 DH 53x74 R PG30.pdf</a>  <a href="#">FL5167 R26 C CAC 07-75 DH 53x80 R PG40.pdf</a>  <a href="#">FL5167 R26 C CAC 07-75 waiver to 07-09.pdf</a>  <a href="#">FL5167 R26 C CAC 75-75 DH 36x63 R PG50.pdf</a>  <a href="#">FL5167 R26 C CAC 75-75 DH 36x74 LC50.pdf</a>  <a href="#">FL5167 R26 C CAC 75-75 DH 48x80 LC PG25.pdf</a>  <a href="#">FL5167 R26 C CAC 75-75 DH 52x71 R PG35.pdf</a>  <b>Quality Assurance Contract Expiration Date</b>                  03/25/2020  <b>Installation Instructions</b>  <a href="#">FL5167 R26 II IN0113 75-75 76-09 07-75 07-09 07-10 07-20 DH 2X.pdf</a>  <a href="#">FL5167 R26 II IN0132-R10 75-75 76-09 07-75 07-09 07-10 07-20 DH 1X.pdf</a>                  Verified By: American Architectural Manufacturers Association                  Created by Independent Third Party:  <b>Evaluation Reports</b></p>

		<a href="#">FL5167 R26 AE EvalReport-IN0132-R10.pdf</a> Created by Independent Third Party: Yes
5167.16	75-75, 75-09, 07-75, 07-09, 07-10 and 07-20	Reflections 5500, Generations, Impressions 9800, 6500 VantagePointe, PerfeXion Platinum Double Hung H-Mulled Triple
<b>Limits of Use</b> <b>Approved for use in HVHZ:</b> No <b>Approved for use outside HVHZ:</b> Yes <b>Impact Resistant:</b> No <b>Design Pressure:</b> +50/-50 <b>Other:</b> 109x74 (+/-50 PSF)		<b>Certification Agency Certificate</b> <a href="#">FL5167 R26 C CAC 07-09-10-20 and 08-09-10-20 Waiver.pdf</a> <a href="#">FL5167 R26 C CAC 07-75 waiver to 07-09.pdf</a> <a href="#">FL5167 R26 C CAC 75-75 DH Triple 109x74 R PG50.pdf</a> <b>Quality Assurance Contract Expiration Date</b> 09/13/2021 <b>Installation Instructions</b> <a href="#">FL5167 R26 II IN0060 75-75 DH Triple or Twin 2X.pdf</a> Verified By: American Architectural Manufacturers Association Created by Independent Third Party: <b>Evaluation Reports</b> Created by Independent Third Party:
5167.17	75-75, 75-09, 07-75, 07-09, 07-10 and 07-20	Reflections 5500, Generations, Impressions 9800, 6500 VantagePointe, PerfeXion Platinum Vinyl Double Hung H-Mulled Twin with Transom
<b>Limits of Use</b> <b>Approved for use in HVHZ:</b> No <b>Approved for use outside HVHZ:</b> Yes <b>Impact Resistant:</b> No <b>Design Pressure:</b> +50/-50 <b>Other:</b> 73x111 *Glazing complies with ASTM E 1300-04.		<b>Certification Agency Certificate</b> <a href="#">FL5167 R26 C CAC 07-75 waiver to 07-09.pdf</a> <a href="#">FL5167 R26 C CAC 75-75 DH Twin w Transom 73x111 R PG50.pdf</a> <b>Quality Assurance Contract Expiration Date</b> 09/13/2021 <b>Installation Instructions</b> <a href="#">FL5167 R26 II IN0062-R7 75-75 DH Twin w Transom.pdf</a> Verified By: American Architectural Manufacturers Association Created by Independent Third Party: <b>Evaluation Reports</b> <a href="#">FL5167 R26 AE EvalReport-IN0062-R7.pdf</a> Created by Independent Third Party: Yes

[Back](#) [Next](#)

Contact Us :: 2601 Blair Stone Road, Tallahassee FL 32399 Phone: 850-487-1824

The State of Florida is an AA/EEO employer. [Copyright 2007-2013 State of Florida](#). :: [Privacy Statement](#) :: [Accessibility Statement](#) :: [Refund Statement](#)

Under Florida law, email addresses are public records. If you do not want your e-mail address released in response to a public-records request, do not send electronic mail to this entity. Instead, contact the office by phone or by traditional mail. If you have any questions, please contact 850.487.1395. \*Pursuant to Section 455.275(1), Florida Statutes, effective October 1, 2012, licensees licensed under Chapter 455, F.S. must provide the Department with an email address if they have one. The emails provided may be used for official communication with the licensee. However email addresses are public record. If you do not wish to supply a personal address, please provide the Department with an email address which can be made available to the public. To determine if you are a licensee under Chapter 455, F.S., please click [here](#).



Credit Card  
**Safe**





**MODEL DESIGNATION:** Simonton Series 43-35 / 43-50 Vinyl Double Hung with Transom

**MAXIMUM OVERALL NOMINAL SIZE:** Twin up to 73" x 111"

**DESIGN PRESSURE RATING:** Positive: 35.0 PSF  
Negative: 35.0 PSF

**USABLE CONFIGURATIONS:** 0 / 00

**GENERAL DESCRIPTION:** The head, sill, and side jambs are extruded PVC. The wall thickness through which the anchor screw penetrates is a minimum of 0.070".

NO P.E. SEAL REQUIRED  
INSTALLATION SUPPORTED  
BY AAMA TEST REPORTS

REV. #	REVISIONS:	REVISED BY:	DATE:
1	ADDED MIN. EDGE DIST. NOTE.	B.J.S.	06/17/15
2	REMOVED MIN. EDGE DIST. FROM MULLION ANCHORING BASEPLATE FASTENERS.	LMH	01/04/16
3	ADDED NOTES 11 & 12 - AAMA 800.	LMH	11/10/17
.	.	.	.
.	.	.	.

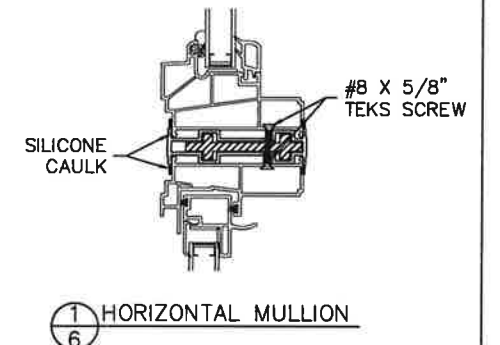
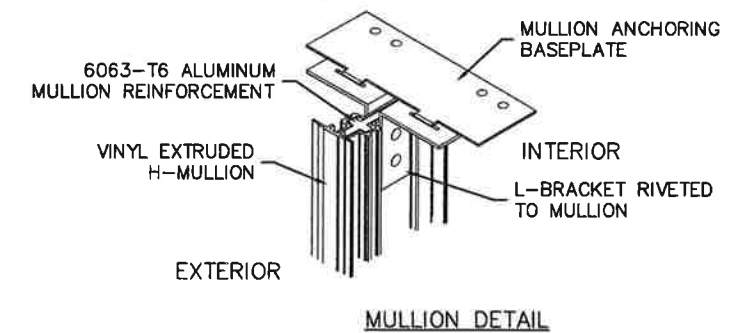
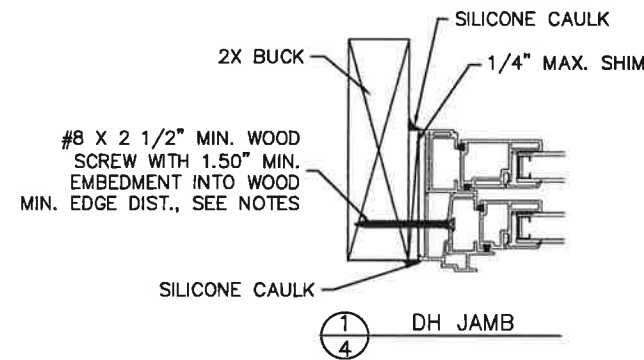
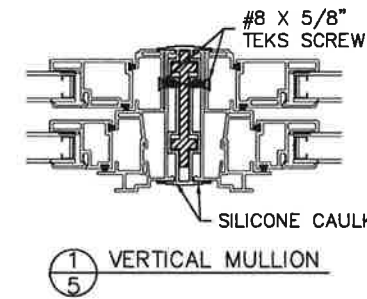
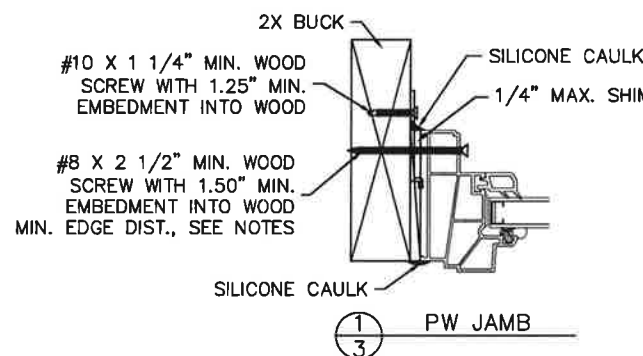
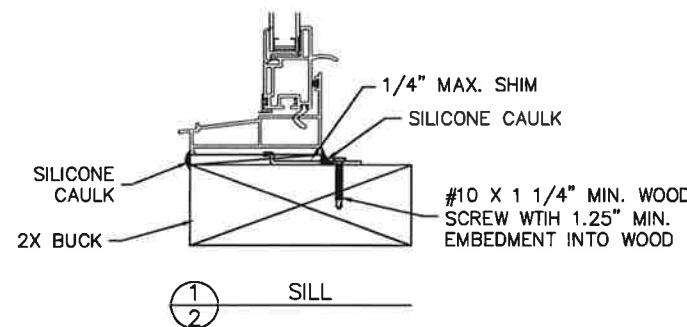
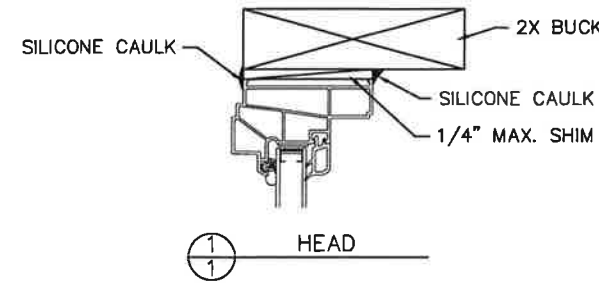
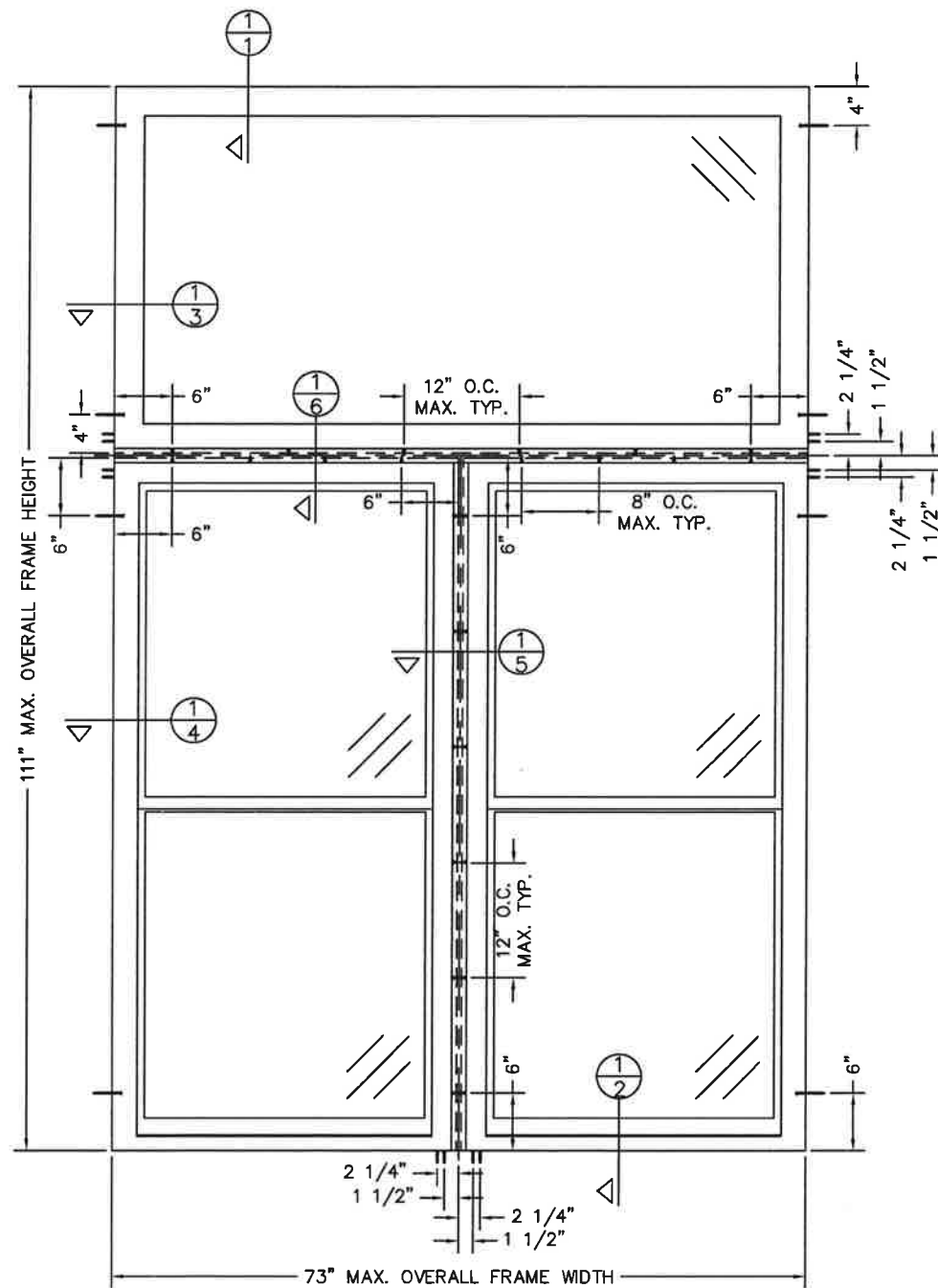

**NOTES:**

1. This installation has been evaluated for use in locations adhering to the Florida Building Code and where pressure requirements as determined by ASCE 7 Minimum Design Loads for Buildings and Other Structures do not exceed the design pressure ratings listed herein. For use outside of the H.V.H.Z.
2. All exterior perimeter surfaces of the window must be caulked. Interior caulking is optional unless noted otherwise.
3. Anchors shall be specified and spaced as shown. Anchor embedment to base material shall be beyond wall dressing or stucco and into wood.
4. The responsibility for selection of Simonton products to meet any applicable local laws, building codes, ordinances or other safety requirements rests solely with the architect, building owner or contractor.
5. Shims are optional. Maximum shim stack is 1/4".
6. Wood bucks (by others) must be engineered and anchored properly to transfer loads to the structure.
7. When used in areas requiring impact protection, this product **REQUIRES** the use of approved impact resistant shutters or other external protection.
8. Flashing should be applied using the ASTM E 2112 method appropriate for the opening into which the window is being installed.
9. Installation screws must be at least 3/4" from the edge of the wood.
10. Glazing shall comply with ASTM E 1300.
11. Use 100% pure silicone caulk compliant with AAMA 808 Section 5 - Sealant Specifications for use with Architectural Fenestration Products. Make sure surfaces are completely free from all old caulk, damaged wood, wood fibers, grease, oil dirt, rust, mold or similar contaminants. Vacuum and clean opening surfaces completely. A fully primed surface is recommended, but not required. Cleaning of all surfaces should be done the same day of which the silicone caulk is to be applied. For more details visit [Simonton.com](http://Simonton.com).
12. Caulk application: recommended air and surface temperatures at the time of application are to be between 40 and 90 degrees F. Insure all contact surfaces are clean and dry including the new window(s). Use a backer rod on all joints >3/4" deep and/or wider than 1/4". Finished caulk joint should be a minimum of 3/8" deep and make full contact with both the new window and structural opening surfaces. Silicone caulk should be forced into joint or compressed to assure full contact on both surfaces and to expel any air pockets.

<p><b>DISCLOSURE STATEMENT</b></p> <p>This document is the property of Simonton Windows, which retains all proprietary and other rights to its subject matter. This document is provided to the recipient on the expressed condition that it is not to be disclosed, reproduced in whole or part, nor used in conjunction with the design, manufacture or repair of goods for anyone other than Simonton Windows without its consent. This restriction does not limit the recipient's rights to utilize information contained in this document which is properly obtained from another source.</p> <p>FILE: IN0535</p>	<p><b>MATERIAL:</b></p> <p>RMS FINISH: EXCEPT AS NOTED</p> <p>ALLOY &amp; TEMPER:</p> <p>WEIGHT: VOLUME:</p> <p>SURFACE AREA: PERIMETER:</p> <p>FINISH TREATMENT:</p>	<p>Dimensional Tolerances Unless Otherwise Specified</p> <p>Decimals Angles</p> <p>.X ± .03 .XX ± .01 .XXX ± .005</p>	<p>SIZE: DRAWING NO.: REV.:</p> <p>B IN0535 3</p> <p>DRAWN BY: DATE:</p> <p>T.D.D. 03/23/12</p> <p>CHECKED BY: DATE:</p> <p>APPR'VD BY: DATE:</p>	
	<p>SCALE: FIT SHEET: 1 of 1</p>	<p>SERIES: 43-35/43-50 DOUBLE HUNG TWIN WITH TRANSOM</p>	<p>TITLE: 2X BUCK INSTALLATION</p>	



**STATE OF FLORIDA  
DEPARTMENT OF BUSINESS AND PROFESSIONAL REGULATION**

**CONSTRUCTION INDUSTRY LICENSING BOARD  
2601 BLAIR STONE ROAD  
TALLAHASSEE FL 32399-0783**

**(850) 487-1395**

**RAMDIAL, BOYSIE GANGA  
THE HOME DEPOT  
2455 PACES FERRY RD, HSC C-11  
ATLANTA GA 30339**

Congratulations! With this license you become one of the nearly one million Floridians licensed by the Department of Business and Professional Regulation. Our professionals and businesses range from architects to yacht brokers, from boxers to barbeque restaurants, and they keep Florida's economy strong.

Every day we work to improve the way we do business in order to serve you better. For information about our services, please go onto [www.myfloridalicense.com](http://www.myfloridalicense.com). There you can find more information about our divisions and the regulations that impact you, subscribe to department newsletters and learn more about the Department's initiatives.

Our mission at the Department is: License Efficiently, Regulate Fairly. We constantly strive to serve you better so that you can serve your customers. Thank you for doing business in Florida, and congratulations on your new license!



**STATE OF FLORIDA  
DEPARTMENT OF BUSINESS AND  
PROFESSIONAL REGULATION**

**CRC046868 ISSUED: 03/13/2017**

**CERTIFIED RESIDENTIAL CONTRACTOR  
RAMDIAL, BOYSIE GANGA  
THE HOME DEPOT**

**IS CERTIFIED under the provisions of Ch. 489 FS.  
Expiration date: AUG 31, 2018 L1703120001282**

DETACH HERE

**RICK SCOTT, GOVERNOR**

**MATILDE MILLER, INTERIM SECRETARY**

**STATE OF FLORIDA  
DEPARTMENT OF BUSINESS AND PROFESSIONAL REGULATION  
CONSTRUCTION INDUSTRY LICENSING BOARD**

**LICENSE NUMBER**

**CRC046868**

**The RESIDENTIAL CONTRACTOR  
Named below IS CERTIFIED  
Under the provisions of Chapter 489 FS.  
Expiration date: AUG 31, 2018**

**RAMDIAL, BOYSIE GANGA  
THE HOME DEPOT  
2455 PACES FERRY RD, HSC C-11  
ATLANTA GA 30339**





# CERTIFICATE OF LIABILITY INSURANCE

DATE (MM/DD/YYYY)  
02/23/2018

THIS CERTIFICATE IS ISSUED AS A MATTER OF INFORMATION ONLY AND CONFERS NO RIGHTS UPON THE CERTIFICATE HOLDER. THIS CERTIFICATE DOES NOT AFFIRMATIVELY OR NEGATIVELY AMEND, EXTEND OR ALTER THE COVERAGE AFFORDED BY THE POLICIES BELOW. THIS CERTIFICATE OF INSURANCE DOES NOT CONSTITUTE A CONTRACT BETWEEN THE ISSUING INSURER(S), AUTHORIZED REPRESENTATIVE OR PRODUCER, AND THE CERTIFICATE HOLDER.

**IMPORTANT:** If the certificate holder is an ADDITIONAL INSURED, the policy(ies) must have ADDITIONAL INSURED provisions or be endorsed. If SUBROGATION IS WAIVED, subject to the terms and conditions of the policy, certain policies may require an endorsement. A statement on this certificate does not confer rights to the certificate holder in lieu of such endorsement(s).

<b>PRODUCER</b> MARSH USA, INC. TWO ALLIANCE CENTER 3580 LENOX ROAD, SUITE 2400 ATLANTA, GA 30329	<b>CONTACT NAME:</b> _____ <b>PHONE (A/C, Mo., Ext.):</b> _____ <b>E-MAIL ADDRESS:</b> _____	<b>FAX (A/C, No.):</b> _____
	<b>INSURER(S) AFFORDING COVERAGE</b>	
CN101642069-HumrC-GW-FL-18- MU	<b>INSURER A:</b> Old Republic Insurance Co	<b>NAIC #</b> 24147
<b>INSURED</b> THE HOME DEPOT, INC. HOME DEPOT U.S.A., INC. 2456 PACES FERRY ROAD BUILDING C 21 ATLANTA, GA 30338	<b>INSURER B:</b> Internatl Ins Co Of North America	<b>NAIC #</b> 43575
	<b>INSURER C:</b>	
	<b>INSURER D:</b>	
	<b>INSURER E:</b>	
	<b>INSURER F:</b>	

**COVERAGES**                      **CERTIFICATE NUMBER:**                      **ATI-004705207-18**                      **REVISION NUMBER: C**

THIS IS TO CERTIFY THAT THE POLICIES OF INSURANCE LISTED BELOW HAVE BEEN ISSUED TO THE INSURED NAMED ABOVE FOR THE POLICY PERIOD INDICATED. NOTWITHSTANDING ANY REQUIREMENT, TERM OR CONDITION OF ANY CONTRACT OR OTHER DOCUMENT WITH RESPECT TO WHICH THIS CERTIFICATE MAY BE ISSUED OR MAY PERTAIN, THE INSURANCE AFFORDED BY THE POLICIES DESCRIBED HEREIN IS SUBJECT TO ALL THE TERMS, EXCLUSIONS AND CONDITIONS OF SUCH POLICIES. LIMITS SHOWN MAY HAVE BEEN REDUCED BY PAID CLAIMS.

INSR. LTR.	TYPE OF INSURANCE	ADDL. SUBR. INSP. WVR.	POLICY NUMBER	POLICY EFF. (MM/DD/YYYY)	POLICY EXP. (MM/DD/YYYY)	LIMITS
A	<input checked="" type="checkbox"/> COMMERCIAL GENERAL LIABILITY <input type="checkbox"/> CLAIMS-MADE <input checked="" type="checkbox"/> OCCUR  GEN'L AGGREGATE LIMIT APPLIES PER: <input checked="" type="checkbox"/> POLICY <input type="checkbox"/> PRO-JECT <input type="checkbox"/> LOC OTHER: _____		MWZY 3/27/17  *LIMITS OF POLICY XS* *OF SIR: \$1M PER OCC*	03/01/2018	03/01/2019	EACH OCCURRENCE \$ 0,000,000 DAMAGE TO RENTED PREMISES (Ea occurrence) \$ 1,000,000 MED EXP (Any one person) \$ EXCLUDED PERSONAL & ALX INJURY \$ 9,000,000 GENERAL AGGREGATE \$ 9,000,000 PRODUCTS - COMPICP AGG \$ 9,000,000 \$ _____
	<b>AUTOMOBILE LIABILITY</b> <input type="checkbox"/> ANY AUTO <input type="checkbox"/> OWNED AUTOS ONLY <input type="checkbox"/> SCHEDULED AUTOS <input type="checkbox"/> NON-OWNED AUTOS ONLY <input type="checkbox"/> HIRED AUTOS ONLY					COMBINED SINGLE LIMIT (Ea accident) \$ _____ BODILY INJURY (Per person) \$ _____ BODILY INJURY (Per accident) \$ _____ PROPERTY DAMAGE (Per accident) \$ _____ \$ _____
	<input type="checkbox"/> UMBRELLA LIAB <input type="checkbox"/> OCCUR <input type="checkbox"/> EXCESS LIAB <input type="checkbox"/> CLAIMS-MADE DED. RETENTION \$ _____					EACH OCCURRENCE \$ _____ AGGREGATE \$ _____ \$ _____
S	<b>WORKERS COMPENSATION AND EMPLOYERS' LIABILITY</b> ANY PROPRIETOR/PARTNER/EXECUTIVE OFFICER/MEMBER EXCLUDED? (Mandatory in NH) If yes, describe under DESCRIPTION OF OPERATIONS below	<input type="checkbox"/> Y <input checked="" type="checkbox"/> N N/A	WLR 034783191 (ALAR,FL,IL,IA,KS,KY,LA,MS,MO,NE,NM,ND,OK,SC,SD,TN,WV,WY)	03/01/2018	03/01/2019	<input checked="" type="checkbox"/> BEN <input type="checkbox"/> STATE <input type="checkbox"/> OTHER E.L. EACH ACCIDENT \$ 5,000,000 E.L. DISEASE - FA EMPLOYEE \$ 5,000,000 E.L. DISEASE - POLICY LIMIT \$ 5,000,000

DESCRIPTION OF OPERATIONS (LOCATIONS / VEHICLES) (ACORD 606, Additional Remarks Schedule, may be attached if more space is required)

<b>CERTIFICATE HOLDER</b>  CITY OF BELLE ISLE 1800 NFLA AVENUE BELLE ISLE, FL 32809	<b>CANCELLATION</b>  SHOULD ANY OF THE ABOVE DESCRIBED POLICIES BE CANCELLED BEFORE THE EXPIRATION DATE THEREOF, NOTICE WILL BE DELIVERED IN ACCORDANCE WITH THE POLICY PROVISIONS.  AUTHORIZED REPRESENTATIVE of Marsh USA Inc. Manashi Mukherjee <i>Manashi Mukherjee</i>
---	---

© 1988-2016 ACORD CORPORATION. All rights reserved.

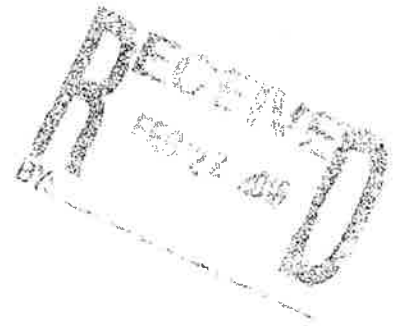

2017 - 2018 HILLSBOROUGH COUNTY BUSINESS TAX RECEIPT  
OCC. CODE 090.022000 RESIDENTIAL CONTRACTOR

EXPIRES SEPTEMBER 30, 2018

ACCOUNT NO.  
35611  
RENEWAL

1 Employees

Receipt Fee 18.00  
Hazardous Waste Surcharge 40.00  
Law Library Fee 0.00

CRC046858

BUSINESS RAMDIAL BOYSIE GANGA  
THE HOME DEPOT  
9208 FLORIDA PALM DR  
TAMPA, FL 33619

# 2017-2018

NAME BOYSIE RAMDIAL  
MAILING C/O: THE HOME DEPOT USA INC  
ADDRESS THE HOME DEPOT  
2466 PACES FERRY RD

Paid 16-890-016173  
07/24/2017 58.00

## BUSINESS TAX RECEIPT

DOUG BELDEN, TAX COLLECTOR  
813-636-8200  
THIS BECOMES A TAX RECEIPT WHEN VALIDATED.

HAS HIGHEST PRIORITY AND IS SUBJECT TO A 10% PENALTY FOR DELAYED PAYMENT  
IF BUSINESS, PROFESSION OR OCCUPATION SPECIFIED HEREON



- [🔍 Searches](#)
- [🔍 Sales Search](#)
- [📄 Results](#)
- [📄 Property Record Card](#)
- [🔖 My Favorites](#)

[Sign up for e-Notify...](#)

**5008 Darden Ave** < 17-23-30-4385-03-280 >

<b>Name(s)</b> 5008 Darden Ave Land Trust	<b>Physical Street Address</b> 5008 Darden Ave
<b>Mailing Address On File</b> C/O Yelena Shamova Trustee 2640 Lake Shore Dr Unit 2009 Riviera Beach, FL 33404-4673	<b>Federal City and Zipcode</b> Orlando, FL 32812
<b>Incorrect Mailing Address?</b>	<b>Property Use</b> 0103 - Single Fam Class III
	<b>Municipality</b> Belle Isle



**View 2017 Property Record Card**

- [Property Features](#)
- [Values, Exemptions and Taxes](#)
- [Sales Analysis](#)
- [Location Info](#)
- [Market Stats](#)
- [🔄 Update Information](#)

**2018 values will be available in August of 2018.**

**Property Description**

LAKE CONWAY ESTATES SECTION SIX Z/17 LOT 328

[View Plat](#)

**Total Land Area** 11,250 sqft (+/-) | 0.26 acres (+/-) GIS Calculated Notice

**Land**

Land Use Code	Zoning	Land Units	Unit Price	Land Value	Class Unit Price	Class Value
0100 - Single Family	R-1-AA	1 LOT(S)	working...	working...	working...	working...

Page 1 of 1 (1 total records)

**Buildings**

Important Information		Structure				
	<b>Model Code:</b>	01 - Single Fam Residence	<b>Actual Year Built:</b>	1967	<b>Gross Area:</b>	2738 sqft
	<b>Type Code:</b>	0103 - Single Fam Class III	<b>Beds:</b>	3	<b>Living Area:</b>	2139 sqft
	<b>Building Value:</b>	working...	<b>Baths:</b>	2.0	<b>Exterior Wall:</b>	Concrete Block Stucco
	<b>Estimated New Cost:</b>	working...	<b>Floors:</b>	1	<b>Interior Wall:</b>	Drywall

Page 1 of 1 (1 total records)

**Extra Features**

Description	Date Built	Units	XFOB Value
PL7 - Above Average Pool	02/18/1994	1 Unit(s)	working...
FPL2 - Average Fireplace	01/01/1978	1 Unit(s)	working...

Page 1 of 1 (2 total records)