



# City of Belle Isle

Universal Engineering Sciences 3532 Maggie Blvd., Orlando, FL 32811  
 Tel 407-581-8161 \* Fax 407-581-0313 \* [www.universalengineering.com](http://www.universalengineering.com)

## PERMIT CARD – PLEASE POST AT JOB SITE

THIS DOCUMENT BECOMES YOUR PERMIT WHEN PROPERLY VALIDATED

Per FBC 105.3.3: An enforcing authority may not issue a building permit for any building construction, erection, alteration, modification, repair or addition unless the permit either includes on its face or there is attached to the permit the following statement: **"NOTICE: In addition to the requirements of this permit, there may be additional restrictions applicable to this property that may be found in the public records of this county, and there may be additional permits required from other governmental entities such as water management districts, state agencies, or federal agencies."** The issuance of this permit does not grant permission to violate any applicable City, Orange County, State of Florida and/or Federal codes and/or ordinances. Separate permits are required for Signs, Roofing, Electrical, Gas, Plumbing and Mechanical services. This permit becomes VOID if the work authorized is not commenced within 6 months, or is suspended or abandoned for a period of 6 months after commencement. **WORK SHALL BE CONSIDERED SUSPENDED IF AN APPROVED INSPECTION HAS NOT BEEN MADE WITHIN A 6 MONTH PERIOD.** PERMISSION IS GRANTED TO DO THE FOLLOWING WORK ACCORDING TO THE CONDITIONS HEREON AND THE APPROVED PLANS AND SPECIFICATIONS, SUBJECT TO COMPLIANCE WITH THE ORDINANCES OF THE CITY OF BELLE ISLE, FLORIDA.

<p><b>Scope of Work:</b> MECHANICAL: one 1.5 ton change out no duct work</p> <p><b>Comments:</b> None</p> <p><b>Project Information</b>        Address: 7232 Seminole Dr, Belle Isle, FL 32812        Parcel ID: 29-23-30-4389-04-132        Property Owner: Malagian, Zachary        Phone Number: 407 383 6356        *****        Company Name: Carpenter's Cooling LLC        Contractor Name: Carpenter, Kevin        License Number: CAC1818573        Address: 3506 Raeford Rd, Orlando, FL 32806        Phone Number: 407 595 5946</p>	<p style="text-align: right;"><b>Permit Number: 2017-04-052</b></p> <p style="text-align: right;">Date of Application: <b>04/13/2017</b>        Date Permit Issued: <b>04/14/2017</b></p> <p style="color: red; font-weight: bold;"><b>WARNING TO OWNER:</b> "YOUR FAILURE TO RECORD A NOTICE OF COMMENCEMENT MAY RESULT IN YOU PAYING TWICE FOR IMPROVEMENTS TO YOUR PROPERTY. IF YOU INTEND TO OBTAIN FINANCING, CONSULT WITH YOUR LENDER OR AN ATTORNEY BEFORE RECORDING YOUR NOTICE OF COMMENCEMENT." ON THE JOB INSPECTION(S) MUST BE MADE BEFORE PROCEEDING WITH SUBSEQUENT WORK. THIS CARD MUST BE DISPLAYED OUTSIDE AND BE PROTECTED FROM THE WEATHER WHILE BEING VISIBLE FROM THE STREET UNTIL THE FINAL INSPECTIONS HAVE BEEN APPROVED.</p>
--	---

### BUILDING FEATURES

<p><b>IMPACT FEES</b></p> <p>Traffic \$        School \$</p> <p><b>ZONING FEES</b></p> <p>Zoning Fee \$</p> <p><b>UNIVERSAL ENG - BUILDING FEES</b></p> <p>Boat Dock \$        Boat House \$        Building \$        Demo \$        Door(s) \$        Driveway \$        Electrical \$        Fence \$        Gas \$        Irrigation \$        Low Voltage \$        Mechanical \$73.50        Plumbing \$        Pool \$        Roofing \$        Screen Encl \$        Shed \$        Temp Pole \$        Window(s) \$</p> <p><b>SURCHARGE FEES</b></p> <p>Surcharge Fee \$2.00        Surcharge Fee \$2.00</p> <p style="color: red; font-weight: bold; text-align: center;"><b>TOTAL FEES \$77.50</b></p> <p><b>Date Paid</b> 4-14-17</p> <p><b>CC or Check #</b> MC 5012</p> <p><b>Amount Paid</b> 77.50</p> <p>The person accepting this permit shall conform to the terms of the application on file and construction shall conform to the requirements of the Florida Building Code (FS 553).</p>	<p style="text-align: center;"><b>BUILDING INSPECTOR USE ONLY</b></p> <p>IF APPLICABLE:        Have Zoning Approval Conditions Been Met? YES NO    Have Stormwater Approval Conditions Been Met? YES NO    Silt fencing in place? YES NO    Turbidity Barrier in place? YES NO</p> <p><input type="checkbox"/> <b>BUILDING</b></p> <p>1<sup>st</sup> _____ (Footing/Foundation)        Survey specific foundation plan must be onsite before slab pour. Approved Plan on Site? ____</p> <p>2<sup>nd</sup> _____ (Slab)</p> <p>3<sup>rd</sup> _____ (Lintel)(Wall Reinforcing on Masonry Building)</p> <p>4<sup>th</sup> _____ (Exterior Framing)(Roof/Wall Sheathing)</p> <p>5<sup>th</sup> _____ (Framing) (To be made after Plumbing/ Mechanical/ Electrical Rough-Ins &amp; Windows/Doors Installed)</p> <p>6<sup>th</sup> _____ (Insulation to be Made After Roof Installed)</p> <p>7<sup>th</sup> _____ (Drywall)</p> <p>8<sup>th</sup> _____ (Sidewalk/Driveway)</p> <p>9<sup>th</sup> _____ (Other)</p> <p>10<sup>th</sup> _____ (Final – After MEP and Other Applicable Finals)</p> <p><input type="checkbox"/> <b>ROOFING</b>    <b>OSHA APPROVED ACCESS MUST BE MADE AVAILABLE TO INSPECTOR</b></p> <p>1<sup>ST</sup> ROOFING Deck Nailing/Dry-in/Flashing _____</p> <p>2<sup>nd</sup> ROOFING Covering In-Progress _____</p> <p>3<sup>rd</sup> ROOFING Covering Final _____</p> <p><input type="checkbox"/> <b>PLUMBING</b> (Pool-Piping, Solar, Irrigation, Water Treatment Equip, Etc...)</p> <p><input type="checkbox"/> 1<sup>ST</sup> _____ (Underground)    2<sup>nd</sup> _____ (Sewer)</p> <p>3<sup>rd</sup> _____ (Rough-In/Tub Set)    4<sup>th</sup> _____ (Final)</p> <p><b>CHECK APPROPRIATE BOX</b></p> <p><input type="checkbox"/> <b>GAS</b> ___ Natural ___ LP    <input type="checkbox"/> <b>MECHANICAL</b>    <input type="checkbox"/> <b>ELECTRICAL</b>    <input type="checkbox"/> <b>LOW VOLTAGE</b></p> <p>1<sup>st</sup> _____ (Rough-In)    2<sup>nd</sup> _____ (Final)</p>
---	--

Inspection requests are to be emailed to [BDscheduling@UniversalEngineering.com](mailto:BDscheduling@UniversalEngineering.com); a confirmation email will be sent back to you upon scheduling. **Next-Day Inspection requests must be made by 4pm.** Please include the following in your request: Permit #, project address, type of inspection, date of the requested inspection, a contact name & a contact phone number. AM or PM may be requested but cannot be guaranteed.

For a copy of your permit, or to check inspection results, please visit <https://universalengineering.sharefile.com>  
 login ID = [cobi@universalengineering.com](mailto:cobi@universalengineering.com)    password = universal13



# City of Belle Isle

Universal Engineering Sciences 3532 Maggie Blvd., Orlando, FL 32811  
Tel 407-581-8161 \* Fax 407-581-0313 \* [www.universalengineering.com](http://www.universalengineering.com)

**RECEIVED**  
APR 13 2017

## APPLICATION FOR MECHANICAL PERMIT

**WARNING TO OWNER:** YOUR FAILURE TO RECORD A NOTICE OF COMMENCEMENT MAY RESULT IN YOUR PAYING TWICE FOR IMPROVEMENTS TO YOUR PROPERTY. A NOTICE OF COMMENCEMENT MUST BE RECORDED AND POSTED ON THE JOB SITE BEFORE THE FIRST INSPECTION. IF YOU INTEND TO OBTAIN FINANCING, CONSULT WITH YOUR LENDER OR AN ATTORNEY BEFORE RECORDING YOUR NOTICE OF COMMENCEMENT.

DATE OF APPLICATION: 4/12/17

PERMIT NUMBER 2017-04-052

PLEASE PRINT. The undersigned hereby applies for a permit to make installations as indicated below:

Project Address 7232 Seminole Drive Belle Isle FL 32809 32812  
Property Owner Zachary Malagian sold to Burke Hammond waiting on it to show on record but copy of deed attached Phone Burke #: 407-383-6356  
Property Owner's Mailing Address 7232 Seminole Drive City Belle Isle  
State FL Zip Code 32812 Parcel Id Number: 29-23-30-4389-04-132

To obtain this information, please visit <http://www.ocpafi.org/Searches/ParcelSearch.aspx>

Class of Building: Old  New  Type of Building: Residential  Commercial  Other   
Type of Work: New  Alteration  Addition  Repair

- **REQUIRED: Tie Down Engineering**
- **REQUIRED: if adding A/C to new space, provide Energy Calculations & Equipment Sizing Calculations**
- **REQUIRED: if replacing unit with no duct work, Duct Certification as per FB 101.4.7.1, must be posted on unit**

Please indicate the nature of work by completing the information below:

**Air Conditioning:** # of Units 1 Tons Per Unit 1.5 Total Tons 1.5  
Type of System: Water to Air  Chiller  Split System  Package  Heat Pump  Estimated Cost \$ 4300.00

**Heating:** # of Units 5 KWS Per Unit 5 k.w. Total KWS 5 k.w. BTU's \_\_\_\_\_  
Oil  Electric  Boiler  Gas  Estimated Cost \$ \_\_\_\_\_

(A) Estimated Cost Fee \$ \_\_\_\_\_

**Fees for items below are based on valuation of all units, equipment, materials and labor supplied by owner or contractor.**

**Ventilation:**  
(Number of) Grease \_\_\_\_\_ Heat \_\_\_\_\_ Hoods, Air Intakes \_\_\_\_\_ Exhaust Fans \_\_\_\_\_ Dryer Vents \_\_\_\_\_ Estimated Cost \$ \_\_\_\_\_

**Refrigeration:** Number of units \_\_\_\_\_ Estimated Cost \$ \_\_\_\_\_

**Piping:** Air \_\_\_\_\_ Vacuum \_\_\_\_\_ Steam \_\_\_\_\_ Chill Water \_\_\_\_\_ Estimated Cost \$ \_\_\_\_\_

**Others:** (Specify) \_\_\_\_\_ Estimated Cost \$ \_\_\_\_\_

Was the space previously Air Conditioned? Yes  No  (B) Estimated Cost Fee \$ \_\_\_\_\_

I hereby certify that the above is true and correct to the best of my knowledge and make Application for Permit as outlined above, and if same is granted I agree to conform to all Florida Building Code Regulations and City Ordinances regulating same and in accordance with plans submitted. The issuance of this permit does not grant permission to violate any applicable Town and/or State of Florida codes and/or ordinances.

LICENSE HOLDER SIGNATURE [Signature] LICENSE # CAC1818573

LICENSE HOLDER NAME Kevin W. Carpenter COMPANY NAME Carpenter's Cooling, LLC

Street Address 3506 Raeford Road

City Orlando State FL Zip Code 32806 Phone Number 4075955946

Email Address carpenterscooling@gmail.com

Building Official: ucg Date 4-13-17  
Verified Contractor's Licenses & Insurance are on file ucg Date 4-13-17

Permit Fee	\$	<u>49</u>
Review Fee	\$	<u>24.50</u>
3% Florida Surcharge	\$	<u>4.-</u>
Total Permit Fee	\$	<u>77.50</u>

NOTE: The Building Permit Number is required if the Mechanical Installation is associated with any construction or alteration where a Building Permit has been issued. Building Permit Number \_\_\_\_\_





Update FL14239 for 2014 Florida Bldg. Code, C-Project dwg

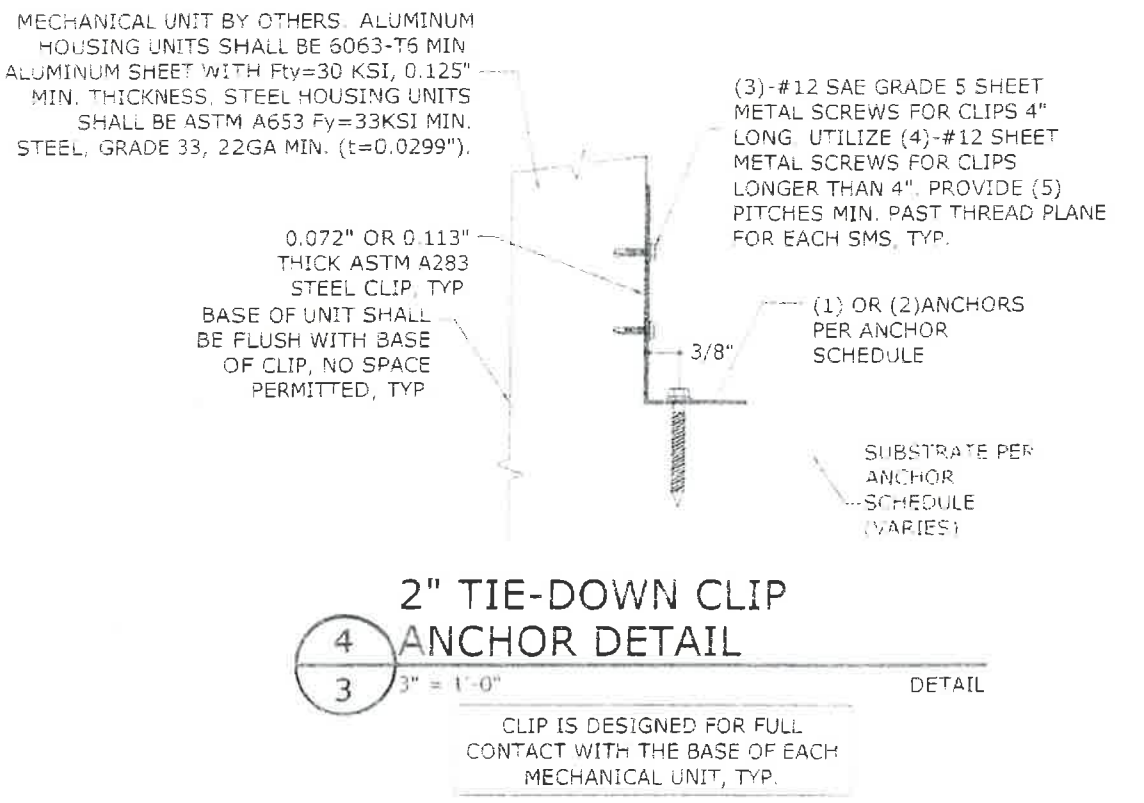
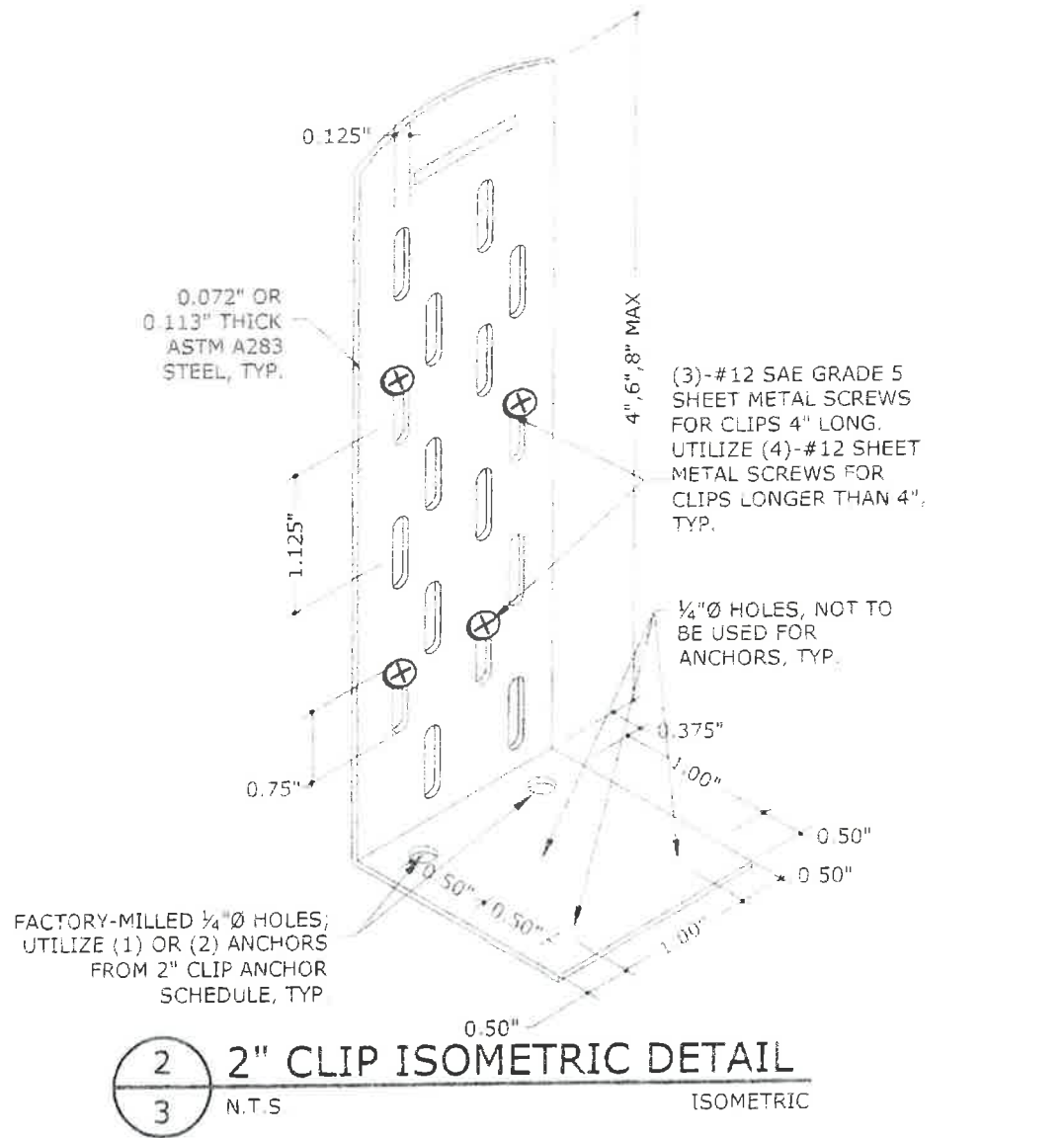
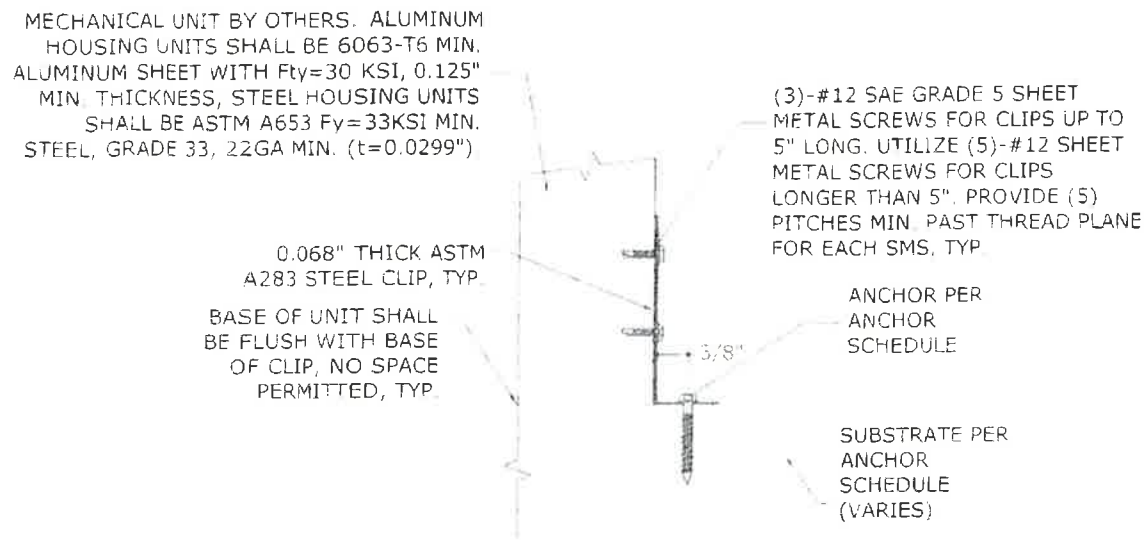
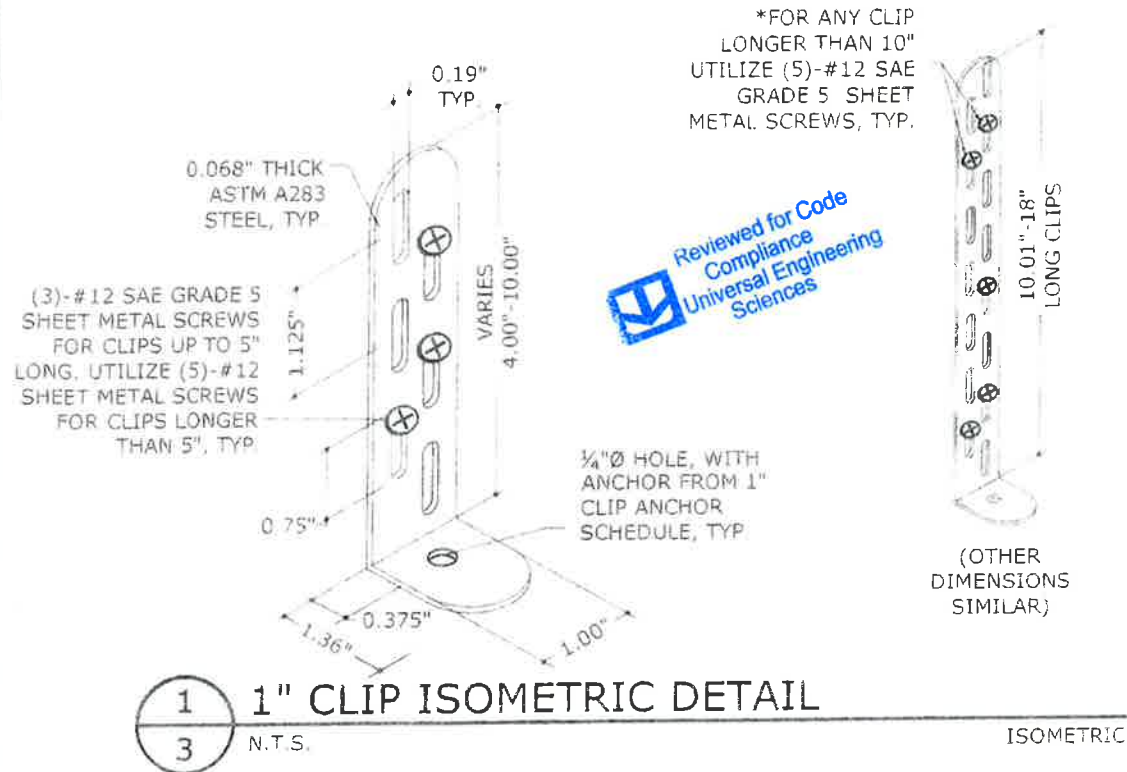

FRANK L. BENNARDO, P.E.  
04/13/2014  
No. 46549  
EX ENGINEERING EXPRESS  
160 SW 12th Avenue, #106  
Deerfield Beach, FL 33442  
Ph: (954) 354-0660 Fax: (954) 354-0443  
WWW.ENGINEERINGEXPRESS.COM  
CERT. OF AUTH. #9885  
A FRANK L. BENNARDO, P.E., INC. INNOVATION

**BMP INTERNATIONAL, INC.**  
4710 28TH STREET NORTH  
ST. PETERSBURG, FL 33471  
PH: (727) 577-1613

MECHANICAL UNIT STEEL TIE-DOWN CLIPS

FBC 5TH EDITION (2014) PRODUCT APPROVAL FL#14239.1

REMARKS	DRWN	CHKD	DATE
INIT ISSUE (11-BMP-0001)	TSB	FLB	12-11-11
REV FOR UNITS	CSL	TSB	02-15-13
REV FOR FBC 5TH (2014)	RWN	CSL	04-06-15

THIS DOCUMENT IS THE PROPERTY OF FRANK L. BENNARDO, P.E. AND SHALL NOT BE REPRODUCED IN WHOLE OR PART WITHOUT WRITTEN CONSENT OF FRANK L. BENNARDO, P.E. - ALL ALTERATIONS, ADDITIONS, DELETIONS, OR OTHER MARKINGS TO THIS DOCUMENT ARE NOT PERMITTED AND WILL BE EVALUATED AS CORRUPTION.

COPYRIGHT FRANK L. BENNARDO P.E.

**15-2378**

SCALE: N.T.S.

PAGE DESCRIPTION:

3

**TABLE 1: Vult=175 MPH, EXPOSURE C**

(FOR USE WITH A RISK CATEGORY II STRUCTURE IN THE HIGH VELOCITY HURRICANE ZONE\*)

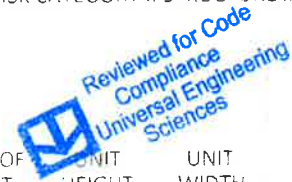

MAXIMUM SURFACE AREA OF UNIT'S LARGEST FACE	UNIT HEIGHT	UNIT WIDTH	ALLOWABLE ROOF-TOP HEIGHT (H) TIE-DOWN CONFIGURATION TYPE			
			C1	C2	C3	C4
6 FT <sup>2</sup>	24" MAX	12" MIN	N/A	AT GRADE	AT GRADE	H ≤ 200 FT
9 FT <sup>2</sup>	32" MAX	15" MIN	N/A	AT GRADE	AT GRADE	H ≤ 60 FT
4 FT <sup>2</sup>	48" MAX	24" MIN	AT GRADE	H ≤ 200 FT	H ≤ 30 FT	H ≤ 200 FT
6 FT <sup>2</sup>			AT GRADE	H ≤ 40 FT	AT GRADE	H ≤ 200 FT
9 FT <sup>2</sup>	48" MAX	24" MIN	N/A	AT GRADE	AT GRADE	H ≤ 160 FT
12 FT <sup>2</sup>			N/A	AT GRADE	AT GRADE	H ≤ 40 FT
16 FT <sup>2</sup>	48" MAX	24" MIN	N/A	AT GRADE	N/A	AT GRADE
20 FT <sup>2</sup>			N/A	AT GRADE	N/A	AT GRADE
25 FT <sup>2</sup>	60" MAX	48" MIN	N/A	AT GRADE	N/A	AT GRADE
30 FT <sup>2</sup>			N/A	N/A	N/A	AT GRADE
36 FT <sup>2</sup>	N/A	N/A	N/A	N/A	N/A	AT GRADE

\*THIS TABLE IS PERMISSIBLE TO BE USED WITHIN THE HVHZ WHICH CONTAINS BROWARD AND MIAMI-DADE COUNTIES. CHECK WITH LOCAL AUTHORITY HAVING JURISDICTION FOR THE APPLICABILITY OF THIS TABLE WITHIN CERTAIN FLORIDA COUNTIES.

**TABLE 2 : Vult=175 MPH, EXPOSURE D**

(FOR USE WITH A RISK CATEGORY II STRUCTURE IN THE HIGH VELOCITY HURRICANE ZONE\*)

MAXIMUM SURFACE AREA OF UNIT'S LARGEST FACE	UNIT HEIGHT	UNIT WIDTH	ALLOWABLE ROOF-TOP HEIGHT (H) TIE-DOWN CONFIGURATION TYPE			
			C1	C2	C3	C4
6 FT <sup>2</sup>	24" MAX	12" MIN	N/A	AT GRADE	AT GRADE	H ≤ 200 FT
9 FT <sup>2</sup>	32" MAX	15" MIN	N/A	AT GRADE	N/A	H ≤ 30 FT
4 FT <sup>2</sup>	48" MAX	24" MIN	AT GRADE	H ≤ 200 FT	AT GRADE	H ≤ 200 FT
6 FT <sup>2</sup>			N/A	H ≤ 15 FT	AT GRADE	H ≤ 200 FT
9 FT <sup>2</sup>	48" MAX	24" MIN	N/A	AT GRADE	AT GRADE	H ≤ 80 FT
12 FT <sup>2</sup>			N/A	AT GRADE	N/A	AT GRADE
16 FT <sup>2</sup>	48" MAX	24" MIN	N/A	AT GRADE	N/A	AT GRADE
20 FT <sup>2</sup>			N/A	AT GRADE	N/A	AT GRADE
25 FT <sup>2</sup>	60" MAX	48" MIN	N/A	N/A	N/A	AT GRADE
30 FT <sup>2</sup>			N/A	N/A	N/A	AT GRADE
36 FT <sup>2</sup>	N/A	N/A	N/A	N/A	N/A	AT GRADE

\*THIS TABLE IS PERMISSIBLE TO BE USED WITHIN THE HVHZ WHICH CONTAINS BROWARD AND MIAMI-DADE COUNTIES. CHECK WITH LOCAL AUTHORITY HAVING JURISDICTION FOR THE APPLICABILITY OF THIS TABLE WITHIN CERTAIN FLORIDA COUNTIES.

**TABLE 3 : Vult=170 MPH, EXPOSURE C**

(FOR USE WITH A RISK CATEGORY II STRUCTURE\*)

MAXIMUM SURFACE AREA OF UNIT'S LARGEST FACE	UNIT HEIGHT	UNIT WIDTH	ALLOWABLE ROOF-TOP HEIGHT (H) TIE-DOWN CONFIGURATION TYPE			
			C1	C2	C3	C4
6 FT <sup>2</sup>	24" MAX	12" MIN	N/A	H ≤ 200 FT	AT GRADE 60 FT < H ≤ 160 FT	H ≤ 200 FT
9 FT <sup>2</sup>	32" MAX	15" MIN	N/A	H ≤ 15 FT 60 FT < H ≤ 200 FT	AT GRADE	H ≤ 200 FT
4 FT <sup>2</sup>	48" MAX	24" MIN	AT GRADE 60 FT < H ≤ 200 FT	H ≤ 200 FT	H ≤ 200 FT	H ≤ 200 FT
6 FT <sup>2</sup>			AT GRADE	H ≤ 200 FT	H ≤ 40 FT 60 FT < H ≤ 200 FT	H ≤ 200 FT
9 FT <sup>2</sup>	48" MAX	24" MIN	N/A	H ≤ 200 FT	AT GRADE 60 FT < H ≤ 80 FT	H ≤ 200 FT
12 FT <sup>2</sup>			N/A	AT GRADE 60 FT < H ≤ 200 FT	N/A	H ≤ 200 FT
16 FT <sup>2</sup>	48" MAX	24" MIN	N/A	AT GRADE	N/A	H ≤ 200 FT
20 FT <sup>2</sup>			N/A	AT GRADE	N/A	H ≤ 200 FT
25 FT <sup>2</sup>	60" MAX	48" MIN	N/A	N/A	N/A	H ≤ 30 FT 60 FT < H ≤ 200 FT
30 FT <sup>2</sup>			N/A	N/A	N/A	AT GRADE 60 FT < H ≤ 180 FT
36 FT <sup>2</sup>	N/A	N/A	N/A	N/A	N/A	AT GRADE

\*AS AN EXAMPLE, THIS TABLE IS PERMISSIBLE TO BE USED WITHIN PALM BEACH COUNTY. CHECK WITH LOCAL AUTHORITY HAVING JURISDICTION FOR THE APPLICABILITY OF THIS TABLE WITHIN CERTAIN FLORIDA COUNTIES.

**TABLE 4 : Vult=170 MPH, EXPOSURE D**

(FOR USE WITH A RISK CATEGORY II STRUCTURE\*)

MAXIMUM SURFACE AREA OF UNIT'S LARGEST FACE	UNIT HEIGHT	UNIT WIDTH	ALLOWABLE ROOF-TOP HEIGHT (H) TIE-DOWN CONFIGURATION TYPE			
			C1	C2	C3	C4
6 FT <sup>2</sup>	24" MAX	12" MIN	N/A	H ≤ 200 FT	AT GRADE 60 FT < H ≤ 80 FT	H ≤ 200 FT
9 FT <sup>2</sup>	32" MAX	15" MIN	N/A	AT GRADE 60 FT < H ≤ 200 FT	N/A	H ≤ 200 FT
4 FT <sup>2</sup>	48" MAX	24" MIN	AT GRADE 60 FT < H ≤ 100 FT	H ≤ 200 FT	H ≤ 200 FT	H ≤ 200 FT
6 FT <sup>2</sup>			N/A	H ≤ 200 FT	H ≤ 15 FT 60 FT < H ≤ 200 FT	H ≤ 200 FT
9 FT <sup>2</sup>	48" MAX	24" MIN	N/A	H ≤ 15 FT 60 FT < H ≤ 200 FT	AT GRADE	H ≤ 200 FT
12 FT <sup>2</sup>			N/A	AT GRADE 60 FT < H ≤ 120 FT	N/A	H ≤ 200 FT
16 FT <sup>2</sup>	48" MAX	24" MIN	N/A	N/A	N/A	H ≤ 40 FT 60 FT < H ≤ 200 FT
20 FT <sup>2</sup>			N/A	AT GRADE	N/A	H ≤ 40 FT 60 FT < H ≤ 200 FT
25 FT <sup>2</sup>	60" MAX	48" MIN	N/A	N/A	N/A	AT GRADE 60 FT < H ≤ 200 FT
30 FT <sup>2</sup>			N/A	N/A	N/A	AT GRADE 60 FT < H ≤ 100 FT
36 FT <sup>2</sup>	N/A	N/A	N/A	N/A	N/A	AT GRADE

\*AS AN EXAMPLE, THIS TABLE IS PERMISSIBLE TO BE USED WITHIN PALM BEACH COUNTY. CHECK WITH LOCAL AUTHORITY HAVING JURISDICTION FOR THE APPLICABILITY OF THIS TABLE WITHIN CERTAIN FLORIDA COUNTIES.

FRANK L. BENNARDO, P.E.  
 PROFESSIONAL ENGINEER  
 No. 46549  
 EX ENGINEERING EXPRESS  
 160 SW 12th AVENUE, #106  
 DEERFIELD BEACH, FL 33442  
 Ph: (954) 354-0660 FAX: (954) 354-0443  
 WWW.ENGP.ORG  
 CERT. OF AUTH. #9865  
 A FRANK L. BENNARDO, P.E., INC. INNOVATION

**BMP INTERNATIONAL, INC.**  
 4710 28TH STREET NORTH  
 ST. PETERSBURG, FL 33471  
 PH: (727) 577-1613

REMARKS	DRWN	CHKD	DATE
INIT ISSUE (11-BMP-0001)	TSB	FLB	12-11-11
REV FOR UNITS	CSL	TSB	02-15-13
REV FOR FBC 5TH (2014)	RWN	CSL	04-06-15

THIS DOCUMENT IS THE PROPERTY OF FRANK L. BENNARDO, P.E. AND SHALL NOT BE REPRODUCED IN WHOLE OR PART WITHOUT WRITTEN CONSENT OF FRANK L. BENNARDO, P.E. - ALL RIGHTS RESERVED. INCLUDING, BUT NOT LIMITED TO, THE RIGHT TO REPRODUCE, COPY, OR TRANSMIT IN ANY FORM OR BY ANY MEANS, ELECTRONIC OR MECHANICAL, INCLUDING PHOTOCOPYING, RECORDING, OR BY ANY INFORMATION STORAGE AND RETRIEVAL SYSTEM.

COPYRIGHT FRANK L. BENNARDO P.E.  
**15-2378**  
 SCALE: N T S  
 PAGE DESCRIPTION:  
 4

**TABLE 5 : Vult=140 MPH, EXPOSURE B**

(FOR USE WITH A RISK CATEGORY II STRUCTURE\*)

MAXIMUM SURFACE AREA OF UNIT'S LARGEST FACE	UNIT HEIGHT	UNIT WIDTH	ALLOWABLE ROOF-TOP HEIGHT (H) TIE-DOWN CONFIGURATION TYPE			
			C2	C3	C4	C4
6 FT <sup>2</sup>	24" MAX	12" MIN	H ≤ 15 FT 60 FT < H ≤ 120 FT	H ≤ 200 FT	H ≤ 200 FT	H ≤ 200 FT
9 FT <sup>2</sup>	32" MAX	15" MIN	AT GRADE	H ≤ 200 FT	H ≤ 200 FT	H ≤ 200 FT
4 FT <sup>2</sup>	48" MAX	24" MIN	H ≤ 200 FT	H ≤ 200 FT	H ≤ 200 FT	H ≤ 200 FT
6 FT <sup>2</sup>			H ≤ 40 FT 60 FT < H ≤ 200 FT	H ≤ 200 FT	H ≤ 200 FT	H ≤ 200 FT
9 FT <sup>2</sup>			AT GRADE 60 FT < H ≤ 80 FT	H ≤ 200 FT	H ≤ 200 FT	H ≤ 200 FT
12 FT <sup>2</sup>			AT GRADE	H ≤ 200 FT	H ≤ 40 FT 60 FT < H ≤ 200 FT	H ≤ 200 FT
16 FT <sup>2</sup>			N/A	H ≤ 200 FT	H ≤ 15 FT 60 FT < H ≤ 100 FT	H ≤ 200 FT
20 FT <sup>2</sup>	60" MAX	48" MIN	N/A	H ≤ 200 FT	H ≤ 15 FT 60 FT < H ≤ 180 FT	H ≤ 200 FT
25 FT <sup>2</sup>			N/A	H ≤ 40 FT 60 FT < H ≤ 200 FT	AT GRADE 60 FT < H ≤ 80 FT	H ≤ 200 FT
30 FT <sup>2</sup>			N/A	H ≤ 15 FT 60 FT < H ≤ 160 FT	AT GRADE	H ≤ 200 FT
36 FT <sup>2</sup>			N/A	AT GRADE 60 FT < H ≤ 80 FT	AT GRADE	H ≤ 200 FT



**TABLE 6 : Vult=140 MPH, EXPOSURE C**

(FOR USE WITH A RISK CATEGORY II STRUCTURE\*)

MAXIMUM SURFACE AREA OF UNIT'S LARGEST FACE	UNIT HEIGHT	UNIT WIDTH	ALLOWABLE ROOF-TOP HEIGHT (H) TIE-DOWN CONFIGURATION TYPE			
			C1	C2	C3	C4
6 FT <sup>2</sup>	24" MAX	12" MIN	AT GRADE	H ≤ 200 FT	H ≤ 200 FT	H ≤ 200 FT
9 FT <sup>2</sup>	32" MAX	15" MIN	N/A	H ≤ 200 FT	H ≤ 15 FT 60 FT < H ≤ 200 FT	H ≤ 200 FT
4 FT <sup>2</sup>	48" MAX	24" MIN	H ≤ 200 FT	H ≤ 200 FT	H ≤ 200 FT	H ≤ 200 FT
6 FT <sup>2</sup>			AT GRADE 60 FT < H ≤ 180 FT	H ≤ 200 FT	H ≤ 200 FT	H ≤ 200 FT
9 FT <sup>2</sup>			AT GRADE	H ≤ 200 FT	H ≤ 40 FT 60 FT < H ≤ 200 FT	H ≤ 200 FT
12 FT <sup>2</sup>			N/A	H ≤ 200 FT	AT GRADE 60 FT < H ≤ 140 FT	H ≤ 200 FT
16 FT <sup>2</sup>			N/A	H ≤ 15 FT 60 FT < H ≤ 200 FT	AT GRADE	H ≤ 200 FT
20 FT <sup>2</sup>	60" MAX	48" MIN	N/A	H ≤ 30 FT 60 FT < H ≤ 200 FT	AT GRADE	H ≤ 200 FT
25 FT <sup>2</sup>			N/A	AT GRADE 60 FT < H ≤ 140 FT	AT GRADE	H ≤ 200 FT
30 FT <sup>2</sup>			N/A	AT GRADE	N/A	H ≤ 200 FT
36 FT <sup>2</sup>			N/A	AT GRADE	N/A	H ≤ 30 FT 60 FT < H ≤ 200 FT

**TABLE 7 : Vult=140 MPH, EXPOSURE D**

(FOR USE WITH A RISK CATEGORY II STRUCTURE\*)

MAXIMUM SURFACE AREA OF UNIT'S LARGEST FACE	UNIT HEIGHT	UNIT WIDTH	ALLOWABLE ROOF-TOP HEIGHT (H) TIE-DOWN CONFIGURATION TYPE			
			C1	C2	C3	C4
6 FT <sup>2</sup>	24" MAX	12" MIN	N/A	H ≤ 200 FT	H ≤ 30 FT 60 FT < H ≤ 200 FT	H ≤ 200 FT
9 FT <sup>2</sup>	32" MAX	15" MIN	N/A	H ≤ 200 FT	AT GRADE 60 FT < H ≤ 140 FT	H ≤ 200 FT
4 FT <sup>2</sup>	48" MAX	24" MIN	H ≤ 40 FT 60 FT < H ≤ 200 FT	H ≤ 200 FT	H ≤ 200 FT	H ≤ 200 FT
6 FT <sup>2</sup>			AT GRADE 60 FT < H ≤ 100 FT	H ≤ 200 FT	H ≤ 200 FT	H ≤ 200 FT
9 FT <sup>2</sup>			N/A	H ≤ 200 FT	H ≤ 15 FT 60 FT < H ≤ 200 FT	H ≤ 200 FT
12 FT <sup>2</sup>			N/A	H ≤ 40 FT 60 FT < H ≤ 200 FT	AT GRADE 60 FT < H ≤ 80 FT	H ≤ 200 FT
16 FT <sup>2</sup>			N/A	AT GRADE 60 FT < H ≤ 200 FT	N/A	H ≤ 200 FT
20 FT <sup>2</sup>	60" MAX	48" MIN	N/A	AT GRADE 60 FT < H ≤ 200 FT	AT GRADE	H ≤ 200 FT
25 FT <sup>2</sup>			N/A	AT GRADE 60 FT < H ≤ 80 FT	N/A	H ≤ 200 FT
30 FT <sup>2</sup>			N/A	N/A	N/A	H ≤ 40 FT 60 FT < H ≤ 200 FT
36 FT <sup>2</sup>			N/A	N/A	N/A	AT GRADE 60 FT < H ≤ 200 FT

\*AS AN EXAMPLE, THESE TABLES ARE PERMISSIBLE TO BE USED WITHIN BREVARD COUNTY. CHECK WITH LOCAL AUTHORITY HAVING JURISDICTION FOR THE APPLICABILITY OF THIS TABLE WITHIN CERTAIN FLORIDA COUNTIES.

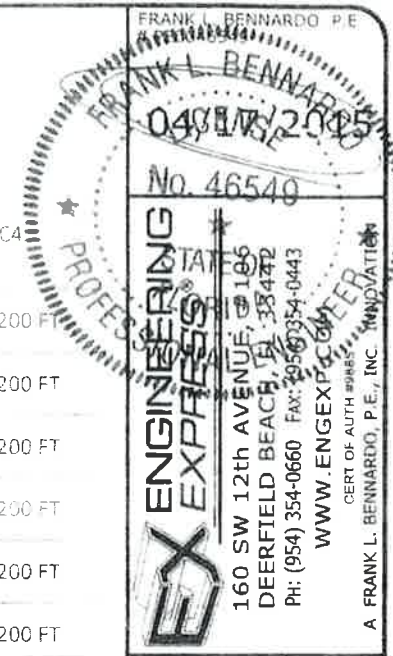

**BMP INTERNATIONAL, INC.**  
4710 28TH STREET NORTH  
ST. PETERSBURG, FL 33471  
PH: (727) 577-1613

MECHANICAL UNIT STEEL TIE-DOWN CLIPS

FBC 5TH EDITION (2014) PRODUCT APPROVAL FL#14239.1

REMARKS	DRWN	CHKD	DATE
INIT ISSUE (14-BMP-0001)	TSB	FLB	12-11-11
REV FOR UNITS	CSL	TSB	02-15-13
REV FOR FBC 5TH (2014)	RWN	CSL	04-08-15

COPYRIGHT FRANK L. BENNARDO P.E.

15-2378

SCALE: N.T.S.

PAGE DESCRIPTION:



PLEASE CUT OUT CARD BELOW AND RETAIN FOR FUTURE REFERENCE

**STATE OF FLORIDA  
DEPARTMENT OF FINANCIAL SERVICES  
DIVISION OF WORKERS' COMPENSATION  
CONSTRUCTION INDUSTRY EXEMPTION**



**CERTIFICATE OF ELECTION TO BE EXEMPT FROM FLORIDA  
WORKERS' COMPENSATION LAW**

**EFFECTIVE DATE:** 3/3/2016      **EXPIRATION DATE:** 3/3/2018

**PERSON:** CARPENTER      KEVIN

**FEIN:** 811618203

**BUSINESS NAME AND ADDRESS:  
CARPENTER'S COOLING LLC**

**4625 LONGWORTH DR  
ORLANDO      FL      32812**

**SCOPES OF BUSINESS OR TRA**

**IMPORTANT**

Pursuant to Chapter 440.05(14), F.S., an officer of a corporation who elects exemption from this chapter by filing a certificate of election under this section may not recover benefits or compensation under this chapter.

Pursuant to Chapter 440.05(12), F.S., Certificates of election to be exempt... apply only within the scope of the business or trade listed on the notice of election to be exempt.

Pursuant to Chapter 440.05(13), F.S., Notices of election to be exempt and certificates of election to be exempt shall be subject to revocation if, at any time after the filing of the notice or the issuance of the certificate, the person named on the notice or certificate no longer meets the requirements of this section for issuance of a certificate. The department shall revoke a certificate at any time for failure of the person named on the certificate to meet the requirements of this section.

F  
O  
L  
D  
  
H  
E  
R  
E

HEATING, VENTILATION,  
AIR-COND



**STATE OF FLORIDA  
DEPARTMENT OF BUSINESS AND PROFESSIONAL REGULATION**

**CONSTRUCTION INDUSTRY LICENSING BOARD  
2601 BLAIR STONE ROAD  
TALLAHASSEE FL 32399-0783**

**(850) 487-1395**

**CARPENTER, KEVIN W  
CARPENTER'S COOLING LLC  
4625 LONGWORTH DR  
ORLANDO FL 32812**

Congratulations! With this license you become one of the nearly one million Floridians licensed by the Department of Business and Professional Regulation. Our professionals and businesses range from architects to yacht brokers, from boxers to barbeque restaurants, and they keep Florida's economy strong.

Every day we work to improve the way we do business in order to serve you better. For information about our services, please log onto [www.myfloridalicense.com](http://www.myfloridalicense.com). There you can find more information about our divisions and the regulations that impact you. subscribe to department newsletters and learn more about the Department's initiatives.

Our mission at the Department is: License Efficiently, Regulate Fairly. We constantly strive to serve you better so that you can serve your customers. Thank you for doing business in Florida, and congratulations on your new license!



DETACH HERE

RICK SCOTT, GOVERNOR

KEN LAWSON, SECRETARY

**STATE OF FLORIDA  
DEPARTMENT OF BUSINESS AND PROFESSIONAL REGULATION  
CONSTRUCTION INDUSTRY LICENSING BOARD**

<b>LICENSE NUMBER</b>	
CAC1818573	

The CLASS B AIR CONDITIONING CONTRACTOR  
Named below IS CERTIFIED  
Under the provisions of Chapter 489 FS.  
Expiration date: AUG 31, 2018



**CARPENTER, KEVIN W  
CARPENTER'S COOLING LLC  
4625 LONGWORTH DR  
ORLANDO FL 32812**



ISSUED: 09/01/2016

DISPLAY AS REQUIRED BY LAW

SEQ # L1609010001775

**Scott Randolph, Tax Collector      Local Business Tax Receipt      Orange County, Florida**

This local business tax receipt is in addition to and not in lieu of any other tax required by law or municipal ordinance. Businesses are subject to regulation of zoning, health and other lawful authorities. This receipt is valid from October 1 through September 30 of receipt year. **Delinquent penalty is added October 1.**

2016      **EXPIRES      9/30/2017**      5000-1165352  
 5000 BUSINESS OFFICE      \$30.00      1      EMPLOYEE      1804      CERT A/C CONTRACTOR      \$30.00      1      EMPLOYEE

TOTAL TAX      \$60.00  
 PREVIOUSLY PAID      \$60.00  
 TOTAL DUE      \$0.00

CARPENTER KEVIN W

CARPENTERS COOLING LLC  
 4625 LONGWORTH DR  
 ORLANDO FL 32812

4625 LONGWORTH DR (MOBILE)  
 U - ORLANDO, 32812

PAID: \$60.00      0098-00755316      9/19/2016

**Scott Randolph, Tax Collector      Local Business Tax Receipt      Orange County, Florida**

This local business tax receipt is in addition to and not in lieu of any other tax required by law or municipal ordinance. Businesses are subject to regulation of zoning, health and other lawful authorities. This receipt is valid from October 1 through September 30 of receipt year. **Delinquent penalty is added October 1.**

2016      **EXPIRES      9/30/2017**      5000-1165352  
 5000 BUSINESS OFFICE      \$30.00      1      EMPLOYEE      1804      CERT A/C CONTRACTOR      \$30.00      1      EMPLOYEE

TOTAL TAX      \$60.00  
 PREVIOUSLY PAID      \$60.00  
 TOTAL DUE      \$0.00



CARPENTER KEVIN W

CARPENTERS COOLING LLC  
 4625 LONGWORTH DR  
 ORLANDO FL 32812

4625 LONGWORTH DR (MOBILE)  
 U - ORLANDO, 32812

PAID: \$60.00      0098-00755316      9/19/2016

This receipt is official when validated by the Tax Collector.

**Orange County Tax Collector Scott Randolph**  
Independently elected to serve only you.

[Pay Online >](#) [Make An Appointment >](#) [Tag Express! >](#)

[ABOUT](#) [LOCATIONS](#) [DRIVER LICENSES](#) [TAG & TITLE](#) [PROPERTY TAX](#) [BUSINESS TAX](#) [CAREERS](#) [OTHER](#) [CONTACT](#)

**Important Notice:** Effective February 1, 2015: The Orange County Tax Collector's office will begin serving only Orange County residents due to volume and budgetary constraints. Please refer to your county's Tax Collector for locations.



### Search Business Taxes

[Search Again](#)

Business Tax Receipt ID: 1165352

<b>Location Address:</b>	4625 LONGWORTH DR	<b>Mailing Address:</b>	CARPENTERS COOLING LLC
<b>Business:</b>	LONGWORTH		4625 LONGWORTH DR
<b>New Business Date:</b>	03/30/2016		ORLANDO, FL 32812
<b>Application Date:</b>	03/30/2016		
<b>Out of Business Date:</b>			

2016	Account Number: 5000-1165352						
Category Type	Display Name	Units	Tax	Exempt	Total Fees	Total Paid	Total Amt Due
5000	BUSINESS OFFICE	1	\$30.00	\$0.00	\$0.00	\$30.00	\$0.00
1804	CERT A/C CONTRACTOR	1	\$30.00	\$0.00	\$0.00	\$30.00	\$0.00
Total For 2016:			\$60.00	\$0.00	\$0.00	\$60.00	\$0.00

This Business Tax Receipt ID has been paid in full



**Mailing Address:**  
ORANGE COUNTY TAX COLLECTOR  
P.O. Box 545100  
Orlando FL 32854

**CONTACT:**  
Motorist Services: 407-845-6200  
Property Tax: 407-836-2700  
Business Tax: 407-836-5650  
Administrative: 407-836-2705

[OFFICE LOCATIONS](#)  
[CONTACT US](#)  
[PRIVACY](#)

[About](#) | [Locations](#) | [Driver Licenses](#) | [Tag & Title](#) | [Property Tax](#) | [Business Tax](#) | [Careers](#) | [Other](#) | [Contact](#)

[Sign In](#)