



# City of Belle Isle

Universal Engineering Sciences 3532 Maggie Blvd., Orlando, FL 32811  
Tel 407-581-8161 \* Fax 407-581-0313 \* [www.universalengineering.com](http://www.universalengineering.com)

## PERMIT CARD – PLEASE POST AT JOB SITE

THIS DOCUMENT BECOMES YOUR PERMIT WHEN PROPERLY VALIDATED

Per FBC 105.3.3: An enforcing authority may not issue a building permit for any building construction, erection, alteration, modification, repair or addition unless the permit either includes on its face or there is attached to the permit the following statement: "NOTICE: In addition to the requirements of this permit, there may be additional restrictions applicable to this property that may be found in the public records of this county, and there may be additional permits required from other governmental entities such as water management districts, state agencies, or federal agencies." The issuance of this permit does not grant permission to violate any applicable City, Orange County, State of Florida and/or Federal codes and/or ordinances. Separate permits are required for Signs, Roofing, Electrical, Gas, Plumbing and Mechanical services. This permit becomes VOID if the work authorized is not commenced within 6 months, or is suspended or abandoned for a period of 6 months after commencement. **WORK SHALL BE CONSIDERED SUSPENDED IF AN APPROVED INSPECTION HAS NOT BEEN MADE WITHIN A 6 MONTH PERIOD.** PERMISSION IS GRANTED TO DO THE FOLLOWING WORK ACCORDING TO THE CONDITIONS HEREON AND THE APPROVED PLANS AND SPECIFICATIONS, SUBJECT TO COMPLIANCE WITH THE ORDINANCES OF THE CITY OF BELLE ISLE, FLORIDA.

<b>Scope of Work:</b> WINDOWS: 6 size for size  <b>Comments:</b> None  <b>Project Information</b> Address: 5130 St. Michael Ave, Belle Isle, FL 32812 Parcel ID: 17-23-30-4380-05-120 Property Owner: Hunter, Jason Phone Number: 407 375 2470 ***** Company Name: Baxter Windows LLC Contractor Name: Baxter, David License Number: CGC1522010 Address: 102 Drennen Rd, suite B11, Orlando, FL 32806 Phone Number: 07 930 1599	<b>Permit Number: 2017-04-033</b> Date of Application: 04/11/2017 Date Permit Issued: 04/12/2017  <b>WARNING TO OWNER:</b> "YOUR FAILURE TO RECORD A NOTICE OF COMMENCEMENT MAY RESULT IN YOU PAYING TWICE FOR IMPROVEMENTS TO YOUR PROPERTY. IF YOU INTEND TO OBTAIN FINANCING, CONSULT WITH YOUR LENDER OR AN ATTORNEY BEFORE RECORDING YOUR NOTICE OF COMMENCEMENT." ON THE JOB INSPECTION(S) MUST BE MADE BEFORE PROCEEDING WITH SUBSEQUENT WORK. THIS CARD MUST BE DISPLAYED OUTSIDE AND BE PROTECTED FROM THE WEATHER WHILE BEING VISIBLE FROM THE STREET UNTIL THE FINAL INSPECTIONS HAVE BEEN APPROVED.
---	---

### BUILDING FEATURES

<b>IMPACT FEES</b> Traffic \$ School \$  <b>ZONING FEES</b> Zoning Fee \$  <b>UNIVERSAL ENG - BUILDING FEES</b> Boat Dock \$ Boat House \$ Building \$ Demo \$ Door(s) \$ Driveway \$ Electrical \$ Fence \$ Gas \$ Irrigation \$ Low Voltage \$ Mechanical \$ Plumbing \$ Pool \$ Roofing \$ Screen Encl \$ Shed \$ Temp Pole \$ Window(s) \$45.50  <b>SURCHARGE FEES</b> Surcharge Fee \$2.00 Surcharge Fee \$2.00  <b>TOTAL FEES \$49.50</b>  Date Paid 4-14-17 CC or Check # MC 4749 Amount Paid 49.50  The person accepting this permit shall conform to the terms of the application on file and construction shall conform to the requirements of the Florida Building Code (FS 553).	<b>BUILDING INSPECTOR USE ONLY</b>  IF APPLICABLE: Have Zoning Approval Conditions Been Met? YES NO    Have Stormwater Approval Conditions Been Met? YES NO    Silt fencing in place? YES NO    Turbidity Barrier in place? YES NO  <input type="checkbox"/> <b>BUILDING</b> 1 <sup>st</sup> _____ (Footing/Foundation) Survey specific foundation plan must be onsite before slab pour. Approved Plan on Site? ____ 2 <sup>nd</sup> _____ (Slab) 3 <sup>rd</sup> _____ (Lintel)(Wall Reinforcing on Masonry Building) 4 <sup>th</sup> _____ (Exterior Framing)(Roof/Wall Sheathing) 5 <sup>th</sup> _____ (Framing) (To be made after Plumbing/ Mechanical/ Electrical Rough-Ins & Windows/Doors Installed) 6 <sup>th</sup> _____ (Insulation to be Made After Roof Installed) 7 <sup>th</sup> _____ (Drywall) 8 <sup>th</sup> _____ (Sidewalk/Driveway) 9 <sup>th</sup> _____ (Other) 10 <sup>th</sup> _____ (Final – After MEP and Other Applicable Finals)  <input type="checkbox"/> <b>ROOFING</b> <b>OSHA APPROVED ACCESS MUST BE MADE AVAILABLE TO INSPECTOR</b> 1 <sup>ST</sup> ROOFING Deck Nailing/Dry-in/Flashing _____ 2 <sup>nd</sup> ROOFING Covering In-Progress _____ 3 <sup>rd</sup> ROOFING Covering Final _____  <input type="checkbox"/> <b>PLUMBING</b> (Pool-Piping, Solar, Irrigation, Water Treatment Equip, Etc...) <input type="checkbox"/> 1 <sup>ST</sup> _____ (Underground)    2 <sup>nd</sup> _____ (Sewer) 3 <sup>rd</sup> _____ (Rough-In/Tub Set)    4 <sup>th</sup> _____ (Final)  <b>CHECK APPROPRIATE BOX</b> <input type="checkbox"/> <b>GAS</b> ___Natural___LP <input type="checkbox"/> <b>MECHANICAL</b> <input type="checkbox"/> <b>ELECTRICAL</b> <input type="checkbox"/> <b>LOW VOLTAGE</b> 1 <sup>st</sup> _____ (Rough-In)    2 <sup>nd</sup> _____ (Final)
--	--

Inspection requests are to be emailed to [BDscheduling@UniversalEngineering.com](mailto:BDscheduling@UniversalEngineering.com); a confirmation email will be sent back to you upon scheduling. Next-Day Inspection requests must be made by 4pm. Please include the following in your request: Permit #, project address, type of inspection, date of the requested inspection, a contact name & a contact phone number. AM or PM may be requested but cannot be guaranteed.

For a copy of your permit, or to check inspection results, please visit <https://universalengineering.sharefile.com>  
login ID = [cobi@universalengineering.com](mailto:cobi@universalengineering.com)    password = universal13



# City of Belle Isle

Universal Engineering Sciences 3532 Maggie Blvd., Orlando, FL 32811  
Tel 407-581-8161 \* Fax 407-581-0313 \* [www.universalengineering.com](http://www.universalengineering.com)

**RECEIVED**  
APR 11 2017  
BY: \_\_\_\_\_

## Building Permit (Land Use) Application

DATE: 4/6/17

PERMIT # 2017-04-033

PROJECT ADDRESS 5130 St Michael Ave Belle Isle Fl 32812, Belle Isle, FL  32809  32812

PROPERTY OWNER JASON HUNTER PHONE 407-375-2470 VALUE OF WORK (labor & material) \$ 3,854<sup>00</sup>

### PLEASE LIST THE NATURE OF YOUR PROPOSED IMPROVEMENTS

6 Replacement Windows, Size for Size, Energy Star 2016, U-Factor, Better than .40, SHGC, Better than .25, All DP's +35

### Please provide information, if applicable.

- **SINGLE FAMILY RESIDENCE:** 8.5"x11" Plat Survey, Plot Plan of Home and Floor Plans of New Construction/Revision Required
- **BOAT DOCK:** DEP Clearance Required with Application (Call 407-897-4100); please provide a copy of their report
- **SEPTIC SYSTEM (RESIDENTIAL):** - Provide verification of OC Health Dept approval for on-site septic tank system, per FAC Chap. 64E-6
- Homeowners will be required to have a contractor on record for homes that are rented and/or not homestead

Please Complete for the City of Belle Isle Zoning Review: Parcel Id Number: 17-23-30-4380-05-120

To obtain this information, please visit <http://www.ocpafi.org/Searches/ParcelSearch.aspx>

**SPECIAL CONDITIONS: STRUCTURES MAY NOT ENCR OACH INTO ANY EASEMENT OR REQUIRED SETBACK.** Survey specific foundation plan required to show compliance with zoning setbacks. Note: this Zoning Approval MAY or MAY NOT be in conflict with your Deed Restrictions. For New Single Family Residence, a Traffic Impact Fee and School Impact will be assessed.

PLANNING & ZONING APPROVAL: \_\_\_\_\_  
DATE \_\_\_\_\_

PLEASE COMPLETE for Building Review (min. of 2 sets of signed/sealed plans required)

CONSTRUCTION TYPE Concrete, Cinder Block

OCCUPANCY GROUP \_\_\_\_\_ Comm \_\_\_\_\_ Res: x \_\_\_\_\_ Single Fam \_\_\_\_\_ x \_\_\_\_\_ Multi Fam \_\_\_\_\_

#BLDG. \_\_\_\_\_ #UNITS \_\_\_\_\_ #STORIES \_\_\_\_\_ TOTAL SQ.FT. \_\_\_\_\_

MAX. FLOOR LOAD \_\_\_\_\_ MAX. OCCUPANCY \_\_\_\_\_

MIN. FLOOD ELEV. \_\_\_\_\_ LOW FLOOR ELEV. \_\_\_\_\_

WATER SERVICE \_\_\_\_\_ WELL \_\_\_\_\_ SEPTIC \_\_\_\_\_

BUILDING REVIEWER scg DATE 4-12-17

VERIFIED CONTRACTOR'S LICENSE & INSURANCE ARE ON FILE SW DATE 4-12-17  
NOCV

#### Per FSS 105.3.3:

An enforcing authority may not issue a building permit for any building construction, erection, alteration, modification, repair or addition unless the permit either includes on its face or there is attached to the permit the following statement: "NOTICE: In addition to the requirements of this permit, there may be additional restrictions applicable to this property that may be found in the public records of this county, and there may be additional permits required from other governmental entities such as water management districts, state agencies, or federal agencies."

Republic Services is by legal contract the sole authorized provider of garbage, recycling, yard waste, and commercial garbage and construction debris collection and disposal services with the city limits of the City. Contractors, homeowners and commercial businesses may contact Republic Services at 407-293-8000 to setup accounts for Commercial, Construction Roll Off, or other services needed. Rates are fixed by contract and are available at City Hall or from Republic Services. The City enforces the contract through its code enforcement office. Failure to comply will result in a stop work order.

**SEPARATE PERMITS ARE REQUIRED FOR ROOFING, ELECTRICAL, PLUMBING, GAS, MECHANICAL, SIGNS, POOLS, ENCLOSURES, ETC.**

15T 11C  
3x4

25  
12  
37 = 2  
18.50  
45.50

Wind Exposure Category: B \_\_\_\_\_ C \_\_\_\_\_ D \_\_\_\_\_

SPRINKLERS REQ'D Y N \_\_\_\_\_  
If Required - SUBMIT COPY OF PLANS FOR FIRE REVIEW Date: Sent \_\_\_\_\_ RCD \_\_\_\_\_

ZONING	Y	N	\$ _____
CERT OF OCC	Y	N	\$ _____
TRAFFIC	Y	N	\$ _____
SCHOOL	Y	N	\$ _____
FIRE	Y	N	\$ _____
SWIMMING POOL	Y	N	\$ _____
SCREEN ENCLOSURE	Y	N	\$ _____
ROOFING	Y	N	\$ _____
BOAT DOCK	Y	N	\$ _____
BUILDING	Y	N	\$ <u>45.50</u>
WINDOW(S)	Y	N	\$ _____
DOOR(S)	Y	N	\$ _____
FENCE	Y	N	\$ _____
SHED	Y	N	\$ _____
DRIVEWAY	Y	N	\$ _____
OTHER	Y	N	\$ _____

3% FL SURCHARGE 4.-  
TOTAL 49.50

By Owner Form Y NA

Notice of Commencement Y NA

Power of Attorney Y NA

Contractor Packet Included? Y N

OTHER PERMITS REQUIRED:

ELECTRICAL Y NA

PREPOWER Y NA

MECHANICAL Y NA

PLUMBING Y NA

ROOFING Y NA

GAS Y NA



City of Belle Isle  
 Universal Engineering Sciences 3532 Maggie Blvd., Orlando, FL 32811  
 Tel 407-581-8161 \* Fax 407-581-0313 \* [www.universalengineering.com](http://www.universalengineering.com)

**Building Permit (Land Use) Application**

To be completed as required by State Statute Section 713 and other applicable sections.

PERMIT # 2017-04-033

Owner's Name Jason Hunter

Owner's Address 5130 St Michael Ave, Belle Isle Fl 32812

Contractor Name <u>David G Baxter</u>	Company Name <u>Baxter Windows LLC</u>
License # <u>CGC1522010</u>	Company Address <u>102 Drennen Rd, STE B11</u>
Contact Phone/Cell <u>407-930-1599</u>	City, State, ZIP <u>Orlando, Fl 32806</u>
Contact Email <u>Info@baxterwindows.com</u>	Contact Fax <u>407-930-1599</u>

**WARNING TO OWNER:** Your failure to record a Notice of Commencement may result in your paying twice for improvements to your property. A notice of commencement must be recorded if job is \$2500(+) or if A/C Replacement \$7500(+) and posted on the job site before the first inspection. If you intend to obtain financing, consult with your lender or an attorney before recording your Notice of Commencement.

I hereby make Application for Permit as outlined above, and if same is granted I agree to conform to all Division of Building Safety Regulations ([www.floridabuilding.org](http://www.floridabuilding.org)) and City Ordinances ([www.municode.com](http://www.municode.com)) regulating same and in accordance with plans submitted. The issuance of this permit does not grant permission to violate any applicable City and/or State of Florida codes and/or ordinances. Application is hereby made to obtain a permit to do the work and installations as indicated. I certify that no work or installation has commenced prior to the issuance of a permit and that all work will be performed to meet the standards of all laws regulating construction in this jurisdiction. I understand that a **separate** permit must be secured for all other construction including ROOFING, ELECTRICAL, MECHANICAL, PLUMBING, GAS, SIGNS, POOLS, SCREEN ENCLOSURES, ETC.

**OWNER'S AFFIDAVIT:** I certify that all the foregoing information is accurate and that all work will be done in compliance with all applicable laws regulating construction and zoning.

<p><b>Owner Signature</b> <u>[Signature]</u></p> <p>The foregoing instrument was acknowledged before me this <u>03/22/17</u> by <u>Jason Hunter</u> who is personally known to me and who produced <u>Florida Drivers License</u> as identification and who did not take an oath.</p> <p>Notary as to Owner          State of Florida          County of Orange</p>	<p align="center"><b>Impervious Surface Ratio Worksheet</b></p> <p align="center">Development Zoned A-1, A-2, R-1-AAA, R-1-AA, R-1-A, R-1 per City Code, Section 50-74: Impervious Surface Ratio</p> <p>1. Total Lot Area (sqft) X 0.35 = Allowable Impervious Area (BASE).          Total Lot Area _____ X 0.35 =          Allowable Impervious Area (BASE) _____</p> <p>2. Calculate the "proposed" impervious area on the lot. This includes the sum of all areas that do not allow direct percolation of rainwater. Examples include house, pool, deck, driveway, accessory building, etc</p> <ul style="list-style-type: none"> <li>• House _____</li> <li>• Driveway _____</li> <li>• Walkway _____</li> <li>• Accessory Buildings _____</li> <li>• Pool &amp; Spa _____</li> <li>• Deck &amp; Patio _____</li> <li>• Other _____</li> </ul> <p>Actual Impervious Area (AIA) _____</p> <p>3. If AIA is less than BASE, subtract AIA from BASE to determine the amount of impervious area that may be added without providing onsite retention.</p> <p>4. If AIA is greater than BASE, then onsite retention <b>must be provided</b>.</p> <p><u>Assuming 7.5 inches of rainfall based on a 24hr 10 year Rain Event (TP40), the formula is: (7.5 inches rainfall/12 inches p/foot) X (result from line 4) = cubic feet of storage volume needed</u></p>
<p><b>Contractor Signature</b> <u>[Signature]</u></p> <p>COMPANY NAME <u>Baxter Windows LLC</u></p> <p>The foregoing instrument was acknowledged before me this <u>03/22/17</u> by <u>David G. Baxter</u> who is personally known to me and who produced _____ as identification and who did not take an oath.</p> <p>Notary as to Owner          State of Florida          County of Orange</p>	

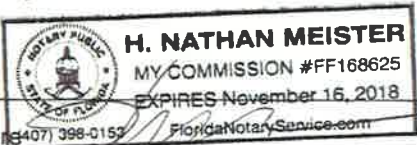

Permit Number: 2017-04-033  
 Folio/Parcel ID #: 17-23-30-4380-05-120  
 Prepared by: Nathan Meister  
 \_\_\_\_\_  
 Return to: 102 Drennen Road, Suite B11  
Orlando, Florida 32806  
 \_\_\_\_\_

DOCH 20170195439  
 04/11/2017 10:22:20 AM Page 1 of 1  
 Rec Fee: \$10.00  
 Phil Diamond, Comptroller  
 Orange County, FL  
 MB - Ret To: DAVID G BAXTER



**NOTICE OF COMMENCEMENT**

State of Florida, County of Orange  
 The undersigned hereby gives notice that improvement will be made to certain real property, and in accordance with Chapter 713, Florida Statutes, the following information is provided in this Notice of Commencement.

1. **Description of property** (legal description of the property, and street address if available)  
Lake Conway Estates Section Two Replat X/150 Lot 12 BLK E, 5130 St. Michael Ave, Belle Isle, Florida
2. **General description of improvement**  
6 Replacement Windows, Size for Size, Energy Star 2015, Hurricane Rated, SHGC Better than .25
3. **Owner information or Lessee information if the Lessee contracted for the improvement**  
 Name Jason & Shannon Hunter  
 Address 5130 St. Michael Ave, Belle Isle, Florida 32812  
 Interest in Property Owner  
 Name and address of fee simple titleholder (if different from Owner listed above)  
 Name N/A  
 Address \_\_\_\_\_
4. **Contractor**  
 Name David G. Baxter Telephone Number 407-930-1599  
 Address 102 Drennen Road Suite B11, Orlando, Florida 32806
5. **Surety** (if applicable, a copy of the payment bond is attached)  
 Name N/A Telephone Number \_\_\_\_\_  
 Address N/A Amount of Bond \$ \_\_\_\_\_
6. **Lender**  
 Name N/A Telephone Number \_\_\_\_\_  
 Address N/A
7. **Persons within the State of Florida designated by Owner upon whom notices or other documents may be served as provided by §713.13(1)(a)7, Florida Statutes.**  
 Name Nathan Meister Telephone Number 407-930-1599  
 Address 102 Drennen Road, Suite B11, Orlando, Florida 32806
8. **In addition to himself or herself, Owner designates the following to receive a copy of the Lienor's Notice as provided in §713.13(1)(b), Florida Statutes.**  
 Name Nathan Meister Telephone Number 407-930-1599  
 Address 102 Drennen Road, Suite B11, Orlando, Florida 32806
9. **Expiration date of notice of commencement** (the expiration date will be 1 year from the date of recording unless a different date is specified) 12/31/2017

State of Florida, County of Orange  
 I hereby certify that this is a true copy of the document as reflected in the Official Records  
 PHIL DIAMOND, COUNTY COMPTROLLER  
 BY: [Signature] D.C.  
 DATED: 4/11/17

**WARNING TO OWNER: ANY PAYMENTS MADE BY THE OWNER AFTER THE EXPIRATION OF THE NOTICE OF COMMENCEMENT ARE CONSIDERED IMPROPER PAYMENTS UNDER CHAPTER 713, PART I, SECTION 713.13, FLORIDA STATUTES, AND CAN RESULT IN YOUR PAYING TWICE FOR IMPROVEMENTS TO YOUR PROPERTY. A NOTICE OF COMMENCEMENT MUST BE RECORDED AND POSTED ON THE JOB SITE BEFORE THE FIRST INSPECTION. IF YOU INTEND TO OBTAIN FINANCING, CONSULT WITH YOUR LENDER OR AN ATTORNEY BEFORE COMMENCING WORK OR RECORDING YOUR NOTICE OF COMMENCEMENT.**

Signature of Owner or Lessee, or Owner's or Lessee's Authorized Officer/Director/Partner/Manager \_\_\_\_\_  
 Signatory's Title/Office Owner

The foregoing instrument was acknowledged before me this 22<sup>nd</sup> day of 03/2017 by Jason Hunter  
 as Owner for Jason Hunter  
 Type of authority, e.g., officer, trustee, attorney in fact \_\_\_\_\_ Name of party on behalf of whom instrument was executed \_\_\_\_\_

Signature of Notary Public - State of Florida \_\_\_\_\_  
 Print, type, or stamp commissioned name of Notary Public \_\_\_\_\_

Personally Known \_\_\_\_\_ OR Produced ID   
 Type of ID Produced Florida's Online License





**CITY OF BELLE ISLE, FLORIDA**  
 Universal Engineering Sciences 3532 Maggie Blvd., Orlando, FL 32811  
 Tel 407-581-8161 \* Fax 407-581-0313 \* [www.universalengineering.com](http://www.universalengineering.com)

**POWER OF ATTORNEY**

Date 4/4/17

**Nathan Meister & Brenno Da Mota**

I hereby name and appoint \_\_\_\_\_  
 an agent of Baxter Windows LLC  
(Name of Company)

to be my lawful attorney-in-fact to act for me to apply for, receipt for, sign for and do all things necessary to this appointment for (check only one option):

- All permits and applications submitted by this contractor.
- Or
- The specific permit and application for work located at:

\_\_\_\_\_  
(Street Address)

Expiration Date for This Limited Power of Attorney: 12/31/2017

License Holder Name: David G. Baxter

State License Number: CGC1522010

Signature of License Holder: *David G. Baxter*

STATE OF FLORIDA  
 COUNTY OF Orange

The foregoing instrument was acknowledged before me this 4<sup>th</sup> day of April  
2017 by David G. Baxter who is  personally known to me or  
 who has produced \_\_\_\_\_ as identification  
 and who did (did not) take an oath.

*Robyn Plum*  
Signature of Notary

Robyn Plum  
Print or type Notary name

Notary Public - State of Florida  
 Commission No. GG036707  
 My Commission Expires: 1/29/2021

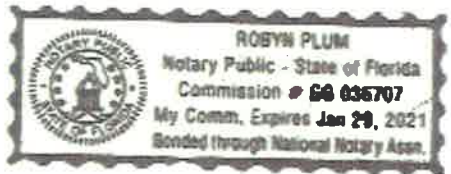



## City of Belle Isle

Universal Engineering Sciences 3532 Maggie Blvd., Orlando, FL 32811  
 Tel 407-581-8161 \* Fax 407-581-0313 \* [www.universalengineering.com](http://www.universalengineering.com)

### Product Approval Form

DATE: 03/06/2017

PERMIT # 2017-04-033

PROJECT ADDRESS 5130 St Michael Ave, Belle Isle FI 32812

Belle Isle, FL  32809  32812

As required by Florida Statute 553.842 and Florida Administrative Code 9B-72m, please provide the information and approval numbers of the building components listed below if they will be utilized on the building or structure. FL Approved products are listed online at [www.floridabuilding.org](http://www.floridabuilding.org) or can be obtained from the local product supplier. The following information must be turned in with permit application and available onsite for inspections:

1. This Product Approval Cover Sheet
2. Internet screen from FloridaBuilding.org showing PA#, approval and code edition stamped
3. Manufacturer's installation details from FloridaBuilding.org and requirements for each product stamped

Product Type	Manufacturer	Model/Series	FL Product Approval #	Product Type	Manufacturer	Model/Series	FL Product Approval #
<b>EXTERIOR DOORS</b>				<b>WALL PANELS</b>			
Swinging				Sliding			
Sliding				Soffits			
Sectional/Rollup				Storefront			
Other				Glass Block			
				Other			
<b>WINDOWS</b>				<b>ROOFING PRODUCTS</b>			
Single/Dbl Hung	Simonton/Amcraft	5050 F5167.13	<u>RL5167.13</u>	Asphalt Shingles			
Horizontal Slider				Non Struct Metal			
Casement				Roofing Tiles			
Fixed				Single Ply Roof			
Mullion				Other			
Skylights							
Other							
<b>STRUCTURAL COMPONENTS</b>				<b>OTHER</b>			
Wood Connectors							
Wood Anchors							
Truss Plates							
Insulation Forms							
Lintels							
Other							

It is the applicant's responsibility to verify that specific products have been installed in accordance with their limitations and with the minimum required design pressures for the structure. Specific compliance will be verified during field inspections.

Applicant Signature \_\_\_\_\_

Date 03/06/17



[BCIS Home](#) | 
 [Log In](#) | 
 [User Registration](#) | 
 [Hot Topics](#) | 
 [Submit Surcharge](#) | 
 [Stats & Facts](#) | 
 [Publications](#) | 
 [FBC Staff](#) | 
 [BCIS Site Map](#) | 
 [Links](#) | 
 [Search](#)



**Product Approval**  
USER: Public User

[Product Approval Menu](#) > 
 [Product or Application Search](#) > 
 [Application List](#) > 
 **Application Detail**



**FL #**  
**Application Type**  
**Code Version**  
**Application Status**

FL5167-R23  
 Revision  
 2014  
 Approved



\*Approved by DBPR. Approvals by DBPR shall be reviewed and ratified by the POC and/or the Commission if necessary.

**Comments**  
 Archived



**Product Manufacturer**  
**Address/Phone/Email**

Simonton Windows  
 1 Cochrane Ave  
 Pennsboro, WV 26415  
 (614) 532-3596  
 luanne.harris@simonton.com

**Authorized Signature**

Luanne Harris  
 luanne.harris@simonton.com

**Technical Representative**  
**Address/Phone/Email**

Luanne Harris  
 3948 Townsfair Way  
 Suite 200  
 Columbus, OH 43219  
 (614) 532-3596  
 luanne.harris@simonton.com

**Quality Assurance Representative**  
**Address/Phone/Email**

AAMA  
 1827 Walden Office Square  
 Suite 550  
 Schaumburg, IL 60173  
 (847) 303-5664  
 webmaster@aamanet.org

**Category**  
**Subcategory**

Windows  
 Double Hung

**Compliance Method**

Certification Mark or Listing

**Certification Agency**  
**Validated By**

American Architectural Manufacturers Association  
 American Architectural Manufacturers Association

**Referenced Standard and Year (of Standard)**

<b>Standard</b>	<b>Year</b>
AAMA 450	2006
AAMA 450	2010
AAMA/WDMA/CSA 101/I.S.2 A440	2005
AAMA/WDMA/CSA 101/I.S.2 A440	2008

**Equivalence of Product Standards**  
**Certified By**

Florida Licensed Professional Engineer or Architect  
[FL5167 R23 Equiv. SimEx-PVC-Equivalency.pdf](#)

Product Approval Method

Method 1 Option A

Date Submitted

08/19/2016

Date Validated

08/26/2016

Date Pending FBC Approval

Date Approved

08/30/2016

Date Revised

04/06/2017

**Summary of Products**

FL #	Model, Number or Name	Description
5167.1	07-09, 07-10 and 07-20	Reflections 5500, Prism Platinum, Sears 9300, Grand Estates Premier Vinyl Double Hung
<b>Limits of Use</b> Approved for use in HVHZ: No Approved for use outside HVHZ: Yes Impact Resistant: No Design Pressure: N/A Other: 48x80 (+/-25 PSF), 56x84 (+/-25 PSF), 53x76 (+/-50 PSF), 36x63 (+/-50 PSF), 44x64 (+/-50 PSF), 47x71 (+/-50 PSF), 37x84 (+/-60 PSF), 37x76 (+/-65 PSF)		<b>Certification Agency Certificate</b> <a href="#">FL5167 R23 C CAC 07-09 DH 36x63 R50.pdf</a> <a href="#">FL5167 R23 C CAC 07-09 DH 37x76 R PG65.pdf</a> <a href="#">FL5167 R23 C CAC 07-09 DH 37x84 R PG60.pdf</a> <a href="#">FL5167 R23 C CAC 07-09 DH 44x63 R50.pdf</a> <a href="#">FL5167 R23 C CAC 07-09 DH 47x71 R PG50.pdf</a> <a href="#">FL5167 R23 C CAC 07-09 DH 48x80 R25.pdf</a> <a href="#">FL5167 R23 C CAC 07-09 DH 53x76 R50.pdf</a> <a href="#">FL5167 R23 C CAC 07-09 DH 56x84 R PG25.pdf</a> <a href="#">FL5167 R23 C CAC 07-09-10-20 and 08-09-10-20 Waiver.pdf</a> <b>Quality Assurance Contract Expiration Date</b> 04/23/2017 <b>Installation Instructions</b> <a href="#">FL5167 R23 II IN0066 SS 07-09 07-10 07-20 DH 1X.pdf</a> <a href="#">FL5167 R23 II IN0067 07-09 07-10 07-20 DH 2X.pdf</a> Verified By: American Architectural Manufacturers Association Created by Independent Third Party: <b>Evaluation Reports</b> <a href="#">FL5167 R23 AE PER3815 07-09 07-10 07-20 DH.pdf</a> Created by Independent Third Party: Yes
5167.2	07-09, 07-10 and 07-20	Reflections 5500, Prism Platinum, Sears 9300, Grand Estates Premier Vinyl Double Hung with Transom
<b>Limits of Use</b> Approved for use in HVHZ: No Approved for use outside HVHZ: Yes Impact Resistant: No Design Pressure: +50/-50 Other: 53x130		<b>Certification Agency Certificate</b> <a href="#">FL5167 R23 C CAC 07-09 DH w Transom 53x130 R PG50.pdf</a> <a href="#">FL5167 R23 C CAC 07-09-10-20 and 08-09-10-20 Waiver.pdf</a> <b>Quality Assurance Contract Expiration Date</b> 04/19/2020 <b>Installation Instructions</b> <a href="#">FL5167 R23 II IN0063 07-09 07-10 07-20 DH w Transom 2X.pdf</a> Verified By: American Architectural Manufacturers Association Created by Independent Third Party: <b>Evaluation Reports</b> Created by Independent Third Party:
5167.3	07-09, 07-10 and 07-20	Reflections 5500, Prism Platinum, Sears 9300, Grand Estates Premier Vinyl Double Hung H-Mulled Triple
<b>Limits of Use</b> Approved for use in HVHZ: No Approved for use outside HVHZ: Yes Impact Resistant: No Design Pressure: +50/-50 Other: 160x76, 126x76		<b>Certification Agency Certificate</b> <a href="#">FL5167 R23 C CAC 07-09 DH Triple 126x76 R PG50.pdf</a> <a href="#">FL5167 R23 C CAC 07-09 DH Triple 160x76 R PG50.pdf</a> <b>Quality Assurance Contract Expiration Date</b> 04/19/2020 <b>Installation Instructions</b> <a href="#">FL5167 R23 II IN0555 07-09 07-10 07-20 DH Twin-Triple.pdf</a> Verified By: American Architectural Manufacturers Association Created by Independent Third Party: <b>Evaluation Reports</b> Created by Independent Third Party:
5167.4	07-09, 07-10 and 07-20	Reflections 5500, Prism Platinum, Sears 9300, Amcraft Grand Estates Premier Vinyl Double Hung Triple with Transom Triple
<b>Limits of Use</b> Approved for use in HVHZ: No		<b>Certification Agency Certificate</b> <a href="#">FL5167 R23 C CAC 07-09 DH Triple w Transom Triple</a>

	<p><b>Approved for use outside HVHZ:</b> Yes  <b>Impact Resistant:</b> No  <b>Design Pressure:</b> +35/-35  <b>Other:</b> 109x88</p>	<p><a href="#">109x88 R PG35.pdf</a>  <a href="#">FL5167 R23 C CAC 07-09-10-20 and 08-09-10-20 Waiver.pdf</a>  <b>Quality Assurance Contract Expiration Date</b>                      12/31/2021  <b>Installation Instructions</b>  <a href="#">FL5167 R23 II IN0556 07-09 07-10 07-20 DH Triple w Transom Triple 2X.pdf</a>                      Verified By: American Architectural Manufacturers Association                      Created by Independent Third Party:  <b>Evaluation Reports</b>                      Created by Independent Third Party:</p>
5167.5	07-20 (Nailing Fin Installation)	Reflections 5500, Prism Platinum, Sears 9300 Vinyl Double Hung
	<p><b>Limits of Use</b>  <b>Approved for use in HVHZ:</b> No  <b>Approved for use outside HVHZ:</b> Yes  <b>Impact Resistant:</b> No  <b>Design Pressure:</b> N/A  <b>Other:</b> 56x84 (+/-25 PSF), 53x76 (+/-50 PSF) &amp; 37x76 (+/-65 PSF)</p>	<p><b>Certification Agency Certificate</b>  <a href="#">FL5167 R23 C CAC 07-20 DH 37x76 R PG65 (ext.).pdf</a>  <a href="#">FL5167 R23 C CAC 07-20 DH 53x76 R PG50 (ext.).pdf</a>  <a href="#">FL5167 R23 C CAC 07-20 DH 56x84 R PG25 (ext.).pdf</a>  <b>Quality Assurance Contract Expiration Date</b>                      07/28/2019  <b>Installation Instructions</b>  <a href="#">FL5167 R23 II IN0129 07-20 DH 2X.pdf</a>                      Verified By: American Architectural Manufacturers Association                      Created by Independent Third Party:  <b>Evaluation Reports</b>                      Created by Independent Third Party:</p>
5167.6	42-19	ProFinish Brickmould 600 Vinyl Double Hung
	<p><b>Limits of Use</b>  <b>Approved for use in HVHZ:</b> No  <b>Approved for use outside HVHZ:</b> Yes  <b>Impact Resistant:</b> No  <b>Design Pressure:</b> N/A  <b>Other:</b> 52x71 (+/-35 PSF), 48x80 (+/-35 PSF), 36x63 (+/-50 PSF), 36x74 (+/-50 PSF)</p>	<p><b>Certification Agency Certificate</b>  <a href="#">FL5167 R23 C CAC 42-19 DH 36x63 R PG50 (ext.).pdf</a>  <a href="#">FL5167 R23 C CAC 42-19 DH 36x74 R PG50 (ext.).pdf</a>  <a href="#">FL5167 R23 C CAC 42-19 DH 48x80 R PG35 (ext.).pdf</a>  <a href="#">FL5167 R23 C CAC 42-19 DH 52x71 R PG35 (ext.).pdf</a>  <b>Quality Assurance Contract Expiration Date</b>                      09/14/2019  <b>Installation Instructions</b>  <a href="#">FL5167 R23 II IN0130 SS 42-19 DH 1X.pdf</a>  <a href="#">FL5167 R23 II IN0148 42-19 DH 2X.pdf</a>                      Verified By: American Architectural Manufacturers Association                      Created by Independent Third Party:  <b>Evaluation Reports</b>  <a href="#">FL5167 R23 AE PER3816 42-19 DH.pdf</a>                      Created by Independent Third Party: Yes</p>
5167.7	42-19	ProFinish Brickmould 600 Vinyl Double Hung Twin
	<p><b>Limits of Use</b>  <b>Approved for use in HVHZ:</b> No  <b>Approved for use outside HVHZ:</b> Yes  <b>Impact Resistant:</b> No  <b>Design Pressure:</b> N/A  <b>Other:</b> 89x63 (+/-30 PSF), 97x80 (+/-30 PSF), 73x63 (+/-35), 73x76 (+/-50 PSF)</p>	<p><b>Certification Agency Certificate</b>  <a href="#">FL5167 R23 C CAC 42-19 DH Twin 73x63 R PG35 (ext.).pdf</a>  <a href="#">FL5167 R23 C CAC 42-19 DH Twin 73x76 R PG50 (ext.).pdf</a>  <a href="#">FL5167 R23 C CAC 42-19 DH Twin 89x63 R PG30 (ext.).pdf</a>  <a href="#">FL5167 R23 C CAC 42-19 DH Twin 97x80 R PG30 (ext.).pdf</a>  <b>Quality Assurance Contract Expiration Date</b>                      10/05/2019  <b>Installation Instructions</b>  <a href="#">FL5167 R23 II IN0150 42-19 DH Twin 2X.pdf</a>                      Verified By: American Architectural Manufacturers Association                      Created by Independent Third Party:  <b>Evaluation Reports</b>                      Created by Independent Third Party:</p>
5167.8	42-19	ProFinish Brickmould 600 Vinyl Double Hung Triple
	<p><b>Limits of Use</b>  <b>Approved for use in HVHZ:</b> No  <b>Approved for use outside HVHZ:</b> Yes  <b>Impact Resistant:</b> No  <b>Design Pressure:</b> +35/-35  <b>Other:</b> 109x74</p>	<p><b>Certification Agency Certificate</b>  <a href="#">FL5167 R23 C CAC 42-19 DH Triple 109x74 R PG35 (ext.).pdf</a>  <b>Quality Assurance Contract Expiration Date</b>                      10/05/2019  <b>Installation Instructions</b>  <a href="#">FL5167 R23 II IN0151 42-19 DH Triple 2X.pdf</a>                      Verified By: American Architectural Manufacturers Association                      Created by Independent Third Party:  <b>Evaluation Reports</b>                      Created by Independent Third Party:</p>

5167.9	43-17	Profinish Contractor, ProFinish Master and Grand Estates Contractor Vinyl Double Hung
<p><b>Limits of Use</b>  <b>Approved for use in HVHZ:</b> No  <b>Approved for use outside HVHZ:</b> Yes  <b>Impact Resistant:</b> No  <b>Design Pressure:</b> N/A  <b>Other:</b> 36x72 (+/-30 PSF), 48x80 (+/-30 PSF), 53x71 (+/-35 PSF), 44x63 (+/-35 PSF), 48x80 (+/-35 PSF), 36x63 (+/-45 PSF), 44x63 (+/-45 PSF), 26x76 (+/-50 PSF) &amp; 36x74 (+/-50 PSF), 32x62 (+/-50 PSF)</p>		<p><b>Certification Agency Certificate</b>  <a href="#">FL5167_R23_C_CAC_43-17_DH_(Fin)_26x76_R50.pdf</a>  <a href="#">FL5167_R23_C_CAC_43-17_DH_(Fin)_44x63_R_PG35_(ext.).pdf</a>  <a href="#">FL5167_R23_C_CAC_43-17_DH_(Fin)_48x80_R_PG30_(ext.).pdf</a>  <a href="#">FL5167_R23_C_CAC_43-17_DH_(Fin)_48x80_R35.pdf</a>  <a href="#">FL5167_R23_C_CAC_43-17_DH_(Finless)_36x74_R50.pdf</a>  <a href="#">FL5167_R23_C_CAC_43-17_DH_(Finless)_48x80_R35.pdf</a>  <a href="#">FL5167_R23_C_CAC_43-17_DH_32x62_R50.pdf</a>  <a href="#">FL5167_R23_C_CAC_43-17_DH_36x63_R_PG45.pdf</a>  <a href="#">FL5167_R23_C_CAC_43-17_DH_36x72_R30_(ext.).pdf</a>  <a href="#">FL5167_R23_C_CAC_43-17_DH_36x74_R50_(ext.).pdf</a>  <a href="#">FL5167_R23_C_CAC_43-17_DH_44x63_R45.pdf</a>  <a href="#">FL5167_R23_C_CAC_43-17_DH_53x71_R35_(Fin)_(Ext.).pdf</a>  <b>Quality Assurance Contract Expiration Date</b>                      04/24/2017  <b>Installation Instructions</b>  <a href="#">FL5167_R23_II_IN0096_43-17_DH_2X.pdf</a>  <a href="#">FL5167_R23_II_IN0254-R6_43-17_DH_1X.pdf</a>                      Verified By: American Architectural Manufacturers Association                      Created by Independent Third Party:  <b>Evaluation Reports</b>  <a href="#">FL5167_R23_AE_EvalReport-IN0254-R6.pdf</a>                      Created by Independent Third Party: Yes</p>
5167.10	43-17	Profinish Contractor, ProFinish Master and Grand Estates Contractor Vinyl Double Hung T-mulled Twin
<p><b>Limits of Use</b>  <b>Approved for use in HVHZ:</b> No  <b>Approved for use outside HVHZ:</b> Yes  <b>Impact Resistant:</b> No  <b>Design Pressure:</b> N/A  <b>Other:</b> 96x80 (+/-25 PSF), 89x63 (+/-30 PSF), 73x63 (+/-35 PSF) &amp; 72x74 (+/-45 PSF)</p>		<p><b>Certification Agency Certificate</b>  <a href="#">FL5167_R23_C_CAC_43-17_DH_Twin_72x74_R_PG45.pdf</a>  <a href="#">FL5167_R23_C_CAC_43-17_DH_Twin_73x63_R_PG35.pdf</a>  <a href="#">FL5167_R23_C_CAC_43-17_DH_Twin_89x63_R30.pdf</a>  <a href="#">FL5167_R23_C_CAC_43-17_DH_Twin_96x80_R_PG25.pdf</a>  <b>Quality Assurance Contract Expiration Date</b>                      04/22/2017  <b>Installation Instructions</b>  <a href="#">FL5167_R23_II_IN0099_43-17_DH_Twin_2X.pdf</a>                      Verified By: American Architectural Manufacturers Association                      Created by Independent Third Party:  <b>Evaluation Reports</b>                      Created by Independent Third Party:</p>
5167.11	43-35 (Two-Step Sill)	6100 Vantage Pointe, Asure, Prism Gold, Grand Estates Vinyl Double Hung
<p><b>Limits of Use</b>  <b>Approved for use in HVHZ:</b> No  <b>Approved for use outside HVHZ:</b> Yes  <b>Impact Resistant:</b> No  <b>Design Pressure:</b> N/A  <b>Other:</b> 44x63 (+/-25 PSF), 46x84 (+/-25 PSF), 36x72 (+/-30 PSF), 48x80 (+/-35 PSF), 52x71 (+/-35 PSF)</p>		<p><b>Certification Agency Certificate</b>  <a href="#">FL5167_R23_C_CAC_43-35_DH_36x72_R30_(Ext.).pdf</a>  <a href="#">FL5167_R23_C_CAC_43-35_DH_44x63_R25_(ext.).pdf</a>  <a href="#">FL5167_R23_C_CAC_43-35_DH_46x84_R25_(ext.).pdf</a>  <a href="#">FL5167_R23_C_CAC_43-35_DH_48x80_R35_(ext.).pdf</a>  <a href="#">FL5167_R23_C_CAC_43-35_DH_52x71_R35_(ext.).pdf</a>  <b>Quality Assurance Contract Expiration Date</b>                      01/24/2021  <b>Installation Instructions</b>  <a href="#">FL5167_R23_II_IN0105_43-35_DH_2X.pdf</a>  <a href="#">FL5167_R23_II_IN0568_SS_43-35_DH_1x.pdf</a>                      Verified By: American Architectural Manufacturers Association                      Created by Independent Third Party:  <b>Evaluation Reports</b>  <a href="#">FL5167_R23_AE_PER3818_43-35_DH.pdf</a>                      Created by Independent Third Party: Yes</p>
5167.12	43-35 (Two-Step Sill) and 43-50 (Three-Step Sill)	VantagePointe 6100, Asure, Prism Gold, Grand Estates Vinyl Double Hung Twin with Transom
<p><b>Limits of Use</b>  <b>Approved for use in HVHZ:</b> No  <b>Approved for use outside HVHZ:</b> Yes  <b>Impact Resistant:</b> No  <b>Design Pressure:</b> +35/-35  <b>Other:</b> 73x111</p>		<p><b>Certification Agency Certificate</b>  <a href="#">FL5167_R23_C_CAC_43-35_DH_Twin_w_Transom_73x111_R35_(ext).pdf</a>  <a href="#">FL5167_R23_C_CAC_43-50_DH_AAMA_450_R35_73x111_(ext.).pdf</a>  <b>Quality Assurance Contract Expiration Date</b>                      01/24/2021  <b>Installation Instructions</b>  <a href="#">FL5167_R23_II_IN0535_43-35_43-50_DH_Twin_with_Transom_2X.pdf</a>                      Verified By: American Architectural Manufacturers Association                      Created by Independent Third Party:</p>

		<b>Evaluation Reports</b> Created by Independent Third Party:
5167.13	43-40 and 43-45	Reflections 5050, Reflections 5300, Prism Bronze, Prism Ultra Gold Amcraft Grand Estates, Grand Estates Select, THD 6100 Vantage Pointe Vinyl Double Hung
<b>Limits of Use</b> <b>Approved for use in HVHZ:</b> No <b>Approved for use outside HVHZ:</b> Yes <b>Impact Resistant:</b> No <b>Design Pressure:</b> N/A <b>Other:</b> 36x72 (+/-30 PSF), 52x71 (+/-35 PSF), 48x80 (+/-35 PSF), 36x63 (+/-45 PSF), 44x63 (+/-45 PSF), 32x62 (+/-50 PSF), 36x74 (+/-50 PSF)		<b>Certification Agency Certificate</b> <a href="#">FL5167 R23 C CAC 43-40 DH 32x62 R50.pdf</a> <a href="#">FL5167 R23 C CAC 43-40 DH 36x63 R45.pdf</a> <a href="#">FL5167 R23 C CAC 43-40 DH 36x72 R30.pdf</a> <a href="#">FL5167 R23 C CAC 43-40 DH 36x74 R50.pdf</a> <a href="#">FL5167 R23 C CAC 43-40 DH 44x63 R PG45.pdf</a> <a href="#">FL5167 R23 C CAC 43-40 DH 48x80 R35.pdf</a> <a href="#">FL5167 R23 C CAC 43-40 DH 52x71 R35.pdf</a> <a href="#">FL5167 R23 C CAC 43-45 waiver to 43-40.pdf</a> <b>Quality Assurance Contract Expiration Date</b> 11/04/2017 <b>Installation Instructions</b> <a href="#">FL5167 R23 II IN0432b 43-40 43-45 DH 2X.pdf</a> <a href="#">FL5167 R23 II IN0434 SS 43-40 43-45 DH 1X.pdf</a> Verified By: American Architectural Manufacturers Association Created by Independent Third Party: <b>Evaluation Reports</b> <a href="#">FL5167 R23 AE PER3819 43-40 43-35 DH.pdf</a> Created by Independent Third Party: Yes
5167.14	43-50 (Three-Step Sill)	6100 Vantage Pointe, Asure, Prism Gold, Grand Estates Vinyl Double Hung
<b>Limits of Use</b> <b>Approved for use in HVHZ:</b> No <b>Approved for use outside HVHZ:</b> Yes <b>Impact Resistant:</b> No <b>Design Pressure:</b> N/A <b>Other:</b> 52x71 (+/-35 PSF), 36x63 (+/-45 PSF), 44x63 (+/-45 PSF), 32x62 (+/-50 PSF), 36x74 (+/-50 PSF)		<b>Certification Agency Certificate</b> <a href="#">FL5167 R23 C CAC 43-50 DH 32x62 R50 (ext).pdf</a> <a href="#">FL5167 R23 C CAC 43-50 DH 36x63 R45 (ext).pdf</a> <a href="#">FL5167 R23 C CAC 43-50 DH 36x74 R50 (ext).pdf</a> <a href="#">FL5167 R23 C CAC 43-50 DH 44x63 R45 (ext).pdf</a> <a href="#">FL5167 R23 C CAC 43-50 DH 52x71 R35 (ext).pdf</a> <b>Quality Assurance Contract Expiration Date</b> 01/25/2021 <b>Installation Instructions</b> <a href="#">FL5167 R23 II IN0432 43-50 DH 2X.pdf</a> <a href="#">FL5167 R23 II IN0569 SS 43-50 DH 1X.pdf</a> Verified By: American Architectural Manufacturers Association Created by Independent Third Party: <b>Evaluation Reports</b> <a href="#">FL5167 R23 AE PER3820 43-50 DH.pdf</a> Created by Independent Third Party: Yes
5167.15	75-75, 75-09, 07-75, 07-09, 07-10 and 07-20	Reflections 5500, Prism Platinum, Sears 9300, Generations, Impressions 9800, THD 6500 Vantage Pointe, Amcraft Grand Estates Premier/Premium Plus, Grandura Vinyl Double Hung
<b>Limits of Use</b> <b>Approved for use in HVHZ:</b> No <b>Approved for use outside HVHZ:</b> Yes <b>Impact Resistant:</b> No <b>Design Pressure:</b> N/A <b>Other:</b> 48x80 (+/-25 PSF), 53x74 (+/-30 PSF), 48x80 (+/-35 PSF), 52x71 (+/-35 PSF), 53x80 (+/-40 PSF), 36x63 (+/-50 PSF), 36x74 (+/-50 PSF)		<b>Certification Agency Certificate</b> <a href="#">FL5167 R23 C CAC 07-09-10-20 and 08-09-10-20 Waiver.pdf</a> <a href="#">FL5167 R23 C CAC 07-10 07-20 to 07-09 Waiver.pdf</a> <a href="#">FL5167 R23 C CAC 07-75 DH 48x80 R PG35.pdf</a> <a href="#">FL5167 R23 C CAC 07-75 DH 53x74 R PG30.pdf</a> <a href="#">FL5167 R23 C CAC 07-75 DH 53x80 R PG40.pdf</a> <a href="#">FL5167 R23 C CAC 75-75 DH 36x63 R PG50.pdf</a> <a href="#">FL5167 R23 C CAC 75-75 DH 36x74 LC50.pdf</a> <a href="#">FL5167 R23 C CAC 75-75 DH 48x80 LC PG25.pdf</a> <a href="#">FL5167 R23 C CAC 75-75 DH 52x71 R PG35.pdf</a> <b>Quality Assurance Contract Expiration Date</b> 06/06/2017 <b>Installation Instructions</b> <a href="#">FL5167 R23 II IN0113 75-75 75-09 07-75 07-09 07-10 07-20 DH 2X.pdf</a> <a href="#">FL5167 R23 II IN0132 SS 75-75 DH 1X.pdf</a> Verified By: American Architectural Manufacturers Association Created by Independent Third Party: <b>Evaluation Reports</b> <a href="#">FL5167 R23 AE PER3821 75-75 DH.pdf</a> Created by Independent Third Party: Yes
5167.16	75-75, 75-09, 07-75, 07-09, 07-10 and 07-20	Reflections 5500, Prism Platinum, Sears 9300, Generations, Impressions 9800, 6500 Vantage Pointe, Grand Estates Premier/Select, Grandura Vinyl Double Hung H-Mulled Triple
<b>Limits of Use</b> <b>Approved for use in HVHZ:</b> No <b>Approved for use outside HVHZ:</b> Yes <b>Impact Resistant:</b> No		<b>Certification Agency Certificate</b> <a href="#">FL5167 R23 C CAC 07-09-10-20 and 08-09-10-20 Waiver.pdf</a> <a href="#">FL5167 R23 C CAC 07-75 75-09 07-09 to 75-75</a>

	<p><b>Design Pressure:</b> +50/-50  <b>Other:</b> 109x74 (+/-50 PSF)</p>	<p><a href="#">Waiver.pdf</a>  <a href="#">FL5167_R23_C_CAC_75-75_DH_Triple_109x74_R_PG50.pdf</a>  <b>Quality Assurance Contract Expiration Date</b>                  09/13/2021  <b>Installation Instructions</b>  <a href="#">FL5167_R23_II_IN0060_75-75_DH_Triple_or_Twin_2X.pdf</a>                  Verified By: American Architectural Manufacturers Association                  Created by Independent Third Party:  <b>Evaluation Reports</b>                  Created by Independent Third Party:</p>
<p>5167.17</p>	<p>75-75, 75-09, 07-75, 07-09, 07-10 and 07-20</p>	<p>Reflections 5500, Prism Platinum, Sears 9300, Generations, Impressions 9800, THD 6500 Vangtage Pointe, Amcraft Grand Estates Premier/Premium Plus, Grandura Vinyl Double Hung H-Mulled Twin with Transom</p>
<p><b>Limits of Use</b>  <b>Approved for use in HVHZ:</b> No  <b>Approved for use outside HVHZ:</b> Yes  <b>Impact Resistant:</b> No  <b>Design Pressure:</b> +50/-50  <b>Other:</b> 73x111 *Glazing complies with ASTM E 1300-04.</p>		<p><b>Certification Agency Certificate</b>  <a href="#">FL5167_R23_C_CAC_75-75_DH_Twin_w_Transom_73x111_R_PG50.pdf</a>  <a href="#">FL5167_R23_C_CAC_ACP-05_SIM_75-75_07-09_07-75_07-09_75-10_75-20_DH_frame.pdf</a>  <b>Quality Assurance Contract Expiration Date</b>                  09/13/2021  <b>Installation Instructions</b>  <a href="#">FL5167_R23_II_IN0062_75-75_DH_Twin_w_Transom.pdf</a>                  Verified By: American Architectural Manufacturers Association                  Created by Independent Third Party:  <b>Evaluation Reports</b>  <a href="#">FL5167_R23_AE_B5764.04-122-34-r0.pdf</a>                  Created by Independent Third Party: Yes</p>

[Back](#) [Next](#)

[Contact Us](#) :: 2601 Blair Stone Road, Tallahassee FL 32399 Phone: 850-487-1824

The State of Florida is an AA/EEO employer. [Copyright 2007-2013 State of Florida.](#) :: [Privacy Statement](#) :: [Accessibility Statement](#) :: [Refund Statement](#)

Under Florida law, email addresses are public records. If you do not want your e-mail address released in response to a public-records request, do not send electronic mail to this entity. Instead, contact the office by phone or by traditional mail. If you have any questions, please contact 850.487.1395. \*Pursuant to Section 455.275(1), Florida Statutes, effective October 1, 2012, licensees licensed under Chapter 455, F.S., must provide the Department with an email address if they have one. The emails provided may be used for official communication with the licensee. However email addresses are public record. If you do not wish to supply a personal address, please provide the Department with an email address which can be made available to the public. To determine if you are a licensee under Chapter 455, F.S., please click [here](#).

**Product Approval Accepts:**



Credit Card  
**Safe**



NO P.E. SEAL REQUIRED  
INSTALLATION SUPPORTED  
BY AAMA TEST REPORTS

REV. #	REVISIONS:	REVISED BY:	DATE:
9	UPDATED SIZES PER NEW TESTING.	T.D.D.	08/28/13
10	UPDATED SIZES PER NEW TESTING.	T.D.D.	01/29/14
11	ADDED MIN. EDGE DISTANCE NOTES	GJM	06/16/15
12	ADDED NEW SIZE TO CHART	LMH	07/10/15
13	ADDED NOTES 12 & 13 - AAMA 800	LMH	08/18/16

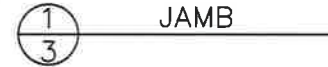
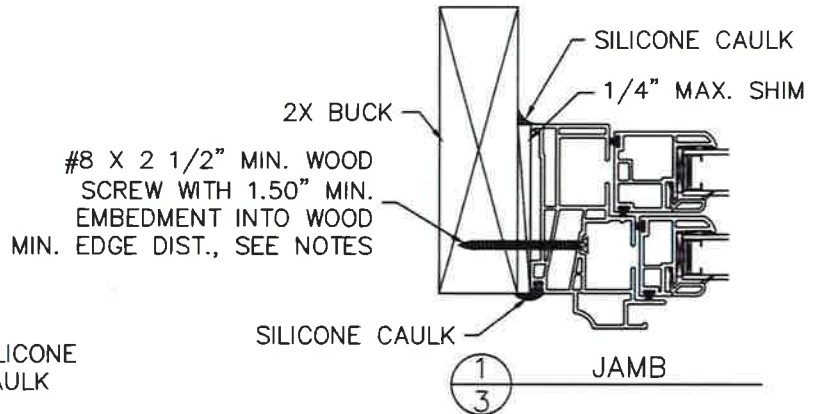
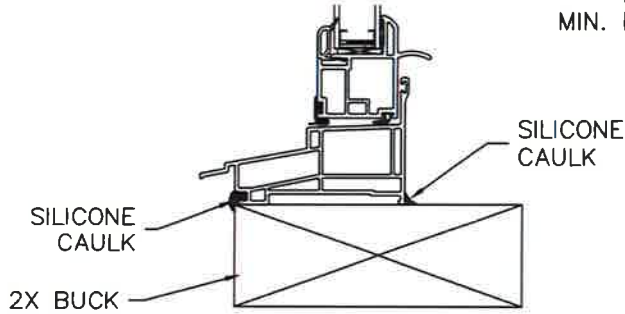
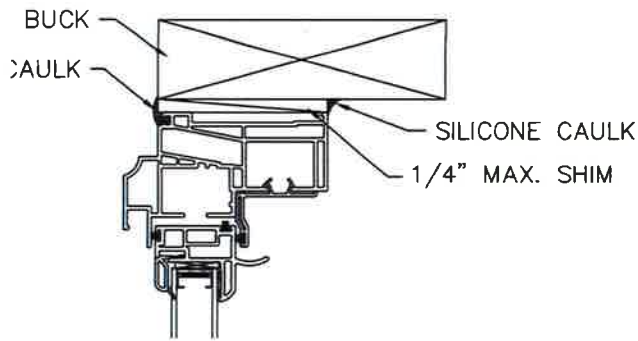

#8 X 2 1/2" MIN. WOOD  
SCREW WITH 1.50" MIN.  
EMBEDMENT INTO WOOD  
MIN. EDGE DIST., SEE NOTES

for use in locations adhering to the Florida Building Codes and where pressure requirements as determined by ASCE 7 Minimum Design  
structures do not exceed the design pressure ratings herein, for use outside the H.V.H.Z.

Window must be caulked. Interior caulking is optional unless noted otherwise.

Installed as shown. Anchor embedment to base material shall be beyond wall dressing or stucco and into wood.

Simonton products to meet any applicable local laws, building codes, ordinances, or other safety requirements rests solely with the architect,

is 1/4".

Engineered and anchored properly to transfer loads to the structure.

For protection this product REQUIRES the use of approved impact resistant shutters or other external protection.

ASTM E 2112 method appropriate for the opening into which the window is being installed.

1/4" from the edge of the wood.

to the interior or exterior track of the jamb. Screws should be flush with the vinyl.

1300-04.

Compliant with AAMA 800 Section 1 - Sealant Specifications for use with Architectural Fenestration Products. Make sure surfaces are completely  
clean, wood fibers, grease, oil dirt, rust, mold or similar contaminants. Vacuum and clean opening surfaces completely. A fully primed surface  
Cleaning of all surfaces should be done the same day of which the silicone caulk is to be applied. For more details visit Simonton.com.

and surface temperatures at the time of application are to be between 40 and 90 degrees F. Insure all contact surfaces are clean and dry  
a backer rod on all joints >3/4" deep and/or wider than 1/4". Finished caulk joint should be a minimum of 3/8" deep and make full contact  
structural opening surfaces. Silicone caulk should be forced into joint or compressed to assure full contact on both surfaces and to expel any air



on Windows, which its subject matter. on the expressed duced in whole or gn, manufacture or imonton Windows es not limit the ontained in this n another source.	MATERIAL:		Dimensional Tolerances Unless Otherwise Specified  Decimals      Angles  .X ± .03 .XX ± .01 .XXX ± .005	 1 Cochrane Avenue Pennsboro, WV 26415	SIZE: DRAWING NO.:	REV.:	
	RMS FINISH:				B	INO113	12
	ALLOY & TEMPER:	EXCEPT AS NOTED			DRAWN BY:	T.D.D.	DATE:
	WEIGHT:	VOLUME:			CHECKED BY:		03/02/07
	SURFACE AREA:	PERIMETER:			APPR'VD BY:		DATE:
FINISH TREATMENT:		SCALE:	FIT	SHEET:	1 of 1		
				SERIES:	75-75 / 75-09 / 07-75 / 07-09 / 07-10 / 07-20 DOUBLE HUNG		
				TITLE:	2X BUCK INSTALLATION (AS TESTED)		



- Searches
- Sales Search
- Results
- Property Record Card**
- My Favorites

Sign up for e-Notify...

**5130 St Michael Ave** < 17-23-30-4380-05-120 >

<b>Names</b>	<b>Physical Street Address</b>
Hunter Jason	5130 St Michael Ave
Hunter Shannon	
<b>Mailing Address On File</b>	<b>Postal City and Zipcode</b>
5130 Saint Michael Ave	Orlando, FL 32812
Belle Isle, FL 32812-1139	<b>Property Use</b>
<a href="#">Incorrect Mailing Address?</a>	0103 - Single Fam Class III
	<b>Municipality</b>
	Belle Isle



**View 2016 Property Record Card**

- Values, Exemptions and Taxes**
- Property Features
- Sales Analysis
- Location Info
- Market Stats
- Update Information

**Note: 2017 values will be available in Spring of 2017.**

**Property Description**

[View Plat](#)

LAKE CONWAY ESTATES SECTION TWO REPLAT X/150 LOT 12 BLK E

**Total Land Area** 11,876 sqft (+/-) | 0.27 acres (+/-) [GIS Calculated](#) [Notice](#)

**Land**

Land Use Code	Zoning	Land Units	Unit Price	Land Value	Class Unit Price	Class Value
0100 - Single Family	R-1-AA	1 LOT(S)	working...	working..	working..	working...

Page 1 of 1 (1 total records)

**Buildings**

Important Information		Structure				
	<b>Model Code:</b>	01 - Single Fam Residence	<b>Actual Year Built:</b>	1963	<b>Gross Area:</b>	3632 sqft
	<b>Type Code:</b>	0103 - Single Fam Class III	<b>Beds:</b>	5	<b>Living Area:</b>	2700 sqft
	<b>Building Value:</b>	working...	<b>Baths:</b>	2.5	<b>Exterior Wall:</b>	Concrete/Cinder Block
	<b>Estimated New Cost:</b>	working...	<b>Floors:</b>	2	<b>Interior Wall:</b>	Drywall

Page 1 of 1 (1 total records)

**Extra Features**

Description	Date Built	Units	XFOB Value
PL2 - Above Average Pool	01/01/1963	1 Unit(s)	working...
FPL2 - Average Fireplace	01/01/1995	1 Unit(s)	working...
PT2 - Patio 2	01/01/2003	1 Unit(s)	working...

Page 1 of 1 (3 total records)

This Data Printed on 04/05/2017 and System Data Last Refreshed on 04/04/2017



### CERTIFICATE OF LIABILITY INSURANCE

DATE (MM/DD/YYYY)  
10/5/2016

THIS CERTIFICATE IS ISSUED AS A MATTER OF INFORMATION ONLY AND CONFERS NO RIGHTS UPON THE CERTIFICATE HOLDER. THIS CERTIFICATE DOES NOT AFFIRMATIVELY OR NEGATIVELY AMEND, EXTEND OR ALTER THE COVERAGE AFFORDED BY THE POLICIES BELOW. THIS CERTIFICATE OF INSURANCE DOES NOT CONSTITUTE A CONTRACT BETWEEN THE ISSUING INSURER(S), AUTHORIZED REPRESENTATIVE OR PRODUCER, AND THE CERTIFICATE HOLDER.

IMPORTANT: If the certificate holder is an ADDITIONAL INSURED, the policy(ies) must be endorsed. If SUBROGATION IS WAIVED, subject to the terms and conditions of the policy, certain policies may require an endorsement. A statement on this certificate does not confer rights to the certificate holder in lieu of such endorsement(s).

<b>PRODUCER</b> Brown & Brown of Florida, Inc. 2290 Lucien Way Suite 400 Maitland FL 32751	<b>CONTACT NAME:</b> Sandra Harrelson <b>PHONE (A/C No. Ext.):</b> (407) 660-8282 <b>FAX (A/C No.):</b> (407) 660-2012 <b>E-MAIL ADDRESS:</b> sharrelson@bborlando.com
	<b>INSURER(S) AFFORDING COVERAGE</b> INSURER A: Ohio Security Ins. Co. NAIC # 24082 INSURER B: INSURER C: INSURER D: INSURER E: INSURER F:

**INSURED**  
 Baxter Windows, LLC  
 185 Drannen Rd Ste 333  
 Orlando FL 32806

**COVERAGES**      **CERTIFICATE NUMBER:** CL1610508691      **REVISION NUMBER:**

THIS IS TO CERTIFY THAT THE POLICIES OF INSURANCE LISTED BELOW HAVE BEEN ISSUED TO THE INSURED NAMED ABOVE FOR THE POLICY PERIOD INDICATED. NOTWITHSTANDING ANY REQUIREMENT, TERM OR CONDITION OF ANY CONTRACT OR OTHER DOCUMENT WITH RESPECT TO WHICH THIS CERTIFICATE MAY BE ISSUED OR MAY PERTAIN, THE INSURANCE AFFORDED BY THE POLICIES DESCRIBED HEREIN IS SUBJECT TO ALL THE TERMS, EXCLUSIONS AND CONDITIONS OF SUCH POLICIES. LIMITS SHOWN MAY HAVE BEEN REDUCED BY PAID CLAIMS.

INSR LTR	TYPE OF INSURANCE	ADOL SUBR (IND. W/O)	POLICY NUMBER	POLICY EFF (MM/DD/YYYY)	POLICY EXP (MM/DD/YYYY)	LIMITS
A	<input checked="" type="checkbox"/> COMMERCIAL GENERAL LIABILITY <input type="checkbox"/> CLAIMS-MADE <input checked="" type="checkbox"/> OCCUR GEN'L AGGREGATE LIMIT APPLIES PER: <input checked="" type="checkbox"/> POLICY <input type="checkbox"/> PRO <input type="checkbox"/> SECT <input type="checkbox"/> LOC <input type="checkbox"/> OTHER:		AL55794394	11/1/2016	11/1/2017	EACH OCCURRENCE \$ 1,000,000 DAMAGE TO RENTED PREMISES (Per occurrence) \$ 300,000 MED EXP (Any one person) \$ 15,000 PERSONAL & ADV INJURY \$ 1,000,000 GENERAL AGGREGATE \$ 2,000,000 PRODUCTS - COMPROP AGG \$ 2,000,000 \$
	<b>AUTOMOBILE LIABILITY</b> <input type="checkbox"/> ANY AUTO <input type="checkbox"/> ALL OWNED AUTOS <input type="checkbox"/> HIRED AUTOS <input type="checkbox"/> SCHEDULED AUTOS <input type="checkbox"/> NON-OWNED AUTOS <b>UMBRELLA LIAB</b> <input type="checkbox"/> OCCUR <b>EXCESS LIAB</b> <input type="checkbox"/> CLAIMS-MADE <input type="checkbox"/> DEF <input type="checkbox"/> RETENTION \$					COMBINED SINGLE LIMIT (Per accident) \$ BODILY INJURY (Per person) \$ BODILY INJURY (Per accident) \$ PROPERTY DAMAGE (Per accident) \$ EACH OCCURRENCE \$ AGGREGATE \$ \$
	<b>WORKERS COMPENSATION AND EMPLOYERS' LIABILITY</b> <input type="checkbox"/> ANY PROPRIETOR/PARTNER/EXECUTIVE OFFICER/MEMBER EXCLUDED? (Mandatory in NH) If yes, describe under DESCRIPTION OF OPERATIONS below Y/N N/A					PER STATUTE <input type="checkbox"/> OTH-ER <input type="checkbox"/> E.L. EACH ACCIDENT \$ E.L. DISEASE - EA EMPLOYEE \$ E.L. DISEASE - POLICY LIMIT \$

DESCRIPTION OF OPERATIONS / LOCATIONS / VEHICLES (ACORD 101, Additional Remarks Schedule, may be attached if more space is required)

<b>CERTIFICATE HOLDER</b>  City of Belle Isle 3532 Maggie Blvd. Orlando, FL 32811	<b>CANCELLATION</b> SHOULD ANY OF THE ABOVE DESCRIBED POLICIES BE CANCELLED BEFORE THE EXPIRATION DATE THEREOF, NOTICE WILL BE DELIVERED IN ACCORDANCE WITH THE POLICY PROVISIONS.  <b>AUTHORIZED REPRESENTATIVE</b> S Harrelson/102120 <i>Sandra Harrelson</i>
---	---



JEFF ATWATER  
CHIEF FINANCIAL OFFICER

STATE OF FLORIDA  
DEPARTMENT OF FINANCIAL SERVICES  
DIVISION OF WORKERS' COMPENSATION

**\*\* CERTIFICATE OF ELECTION TO BE EXEMPT FROM FLORIDA WORKERS' COMPENSATION LAW \*\***

**CONSTRUCTION INDUSTRY EXEMPTION**

This certifies that the individual listed below has elected to be exempt from Florida Workers' Compensation law.

EFFECTIVE DATE: 1/7/2016                      EXPIRATION DATE: 1/6/2018  
PERSON: BAXTER                                      DAVID                                      G  
FEIN: 463774251

**BUSINESS NAME AND ADDRESS:**

BAXTER WINDOWS LLC

102 DRENNEN RD, SUITE B11 & B12  
ORLANDO                      FL                      32806

**SCOPES OF BUSINESS OR TRADE:**

LICENSED GENERAL                      DOOR AND WINDOW                      GLAZIER AWAY FROM                      CARPENTRY DWELLINGS  
CONTRACTOR                      INSTALLATION                      SHOP AND DRJ                      THREE

Pursuant to Chapter 440.05(14), F.S., an officer of a corporation who elects exemption from this chapter by filing a certificate of election under this section may not recover benefits or compensation under this chapter. Pursuant to Chapter 440.05(12), F.S., Certificates of election to be exempt... apply only within the scope of the business or trade listed on the notice of election to be exempt. Pursuant to Chapter 440.05(13), F.S., Notices of election to be exempt and certificates of election to be exempt shall be subject to revocation if, at any time after the filing of the notice or the issuance of the certificate, the person named on the notice or certificate no longer meets the requirements of this section for issuance of a certificate. The department shall revoke a

RICK SCOTT, GOVERNOR

KEN LAWSON, SECRETARY

STATE OF FLORIDA  
DEPARTMENT OF BUSINESS AND PROFESSIONAL REGULATION  
CONSTRUCTION INDUSTRY LICENSING BOARD

LICENSE NUMBER  
CGC1522010

The GENERAL CONTRACTOR  
Named below IS CERTIFIED  
Under the provisions of Chapter 489 FS  
Expiration date: AUG 31, 2018

BAXTER DAVID G  
BAXTER WINDOWS LLC  
102 DRENNEN ROAD SUITE B11 B12  
ORLANDO FL 32806



ISSUED 07/10/2016

DISPLAY AS REQUIRED BY LAW

SEQ # L1507100001351

**Scott Randolph, Tax Collector**

**Local Business Tax Receipt**

**Orange County, Florida**

This local business tax receipt is in addition to and not in lieu of any other tax required by law or municipal ordinance. Businesses are subject to regulation of zoning, health and other annual ordinances. This receipt is valid from October 1 through September 30 of receipt year. Delinquent penalty is added October 1.

3501 GEN CONT - RESIDENTIA 2016 EMPLOYEE 9/30/2017 3501-1119393

TOTAL TAX \$30.00  
PREVIOUSLY PAID \$30.00  
TOTAL DUE \$0.00

186 ORENEN RD #B11-12  
A - ORLANDO, 32806

PAID: \$30.00 0098-00753677 9/15/2016



MASTER HOWARD N  
FAKTER WINDOWS LLC  
186 ORENEN RD  
SUITE B11-12  
ORLANDO FL 32806-0187

**CITY OF ORLANDO**

**2016-2017**

**ECONOMIC DEVELOPMENT  
PERMITTING SERVICES  
LOCAL BUSINESS TAX RECEIPT**

(Formerly known as "Business License," changed per state law 100.000-2000)



**NOTICE:** THIS RECEIPT ONLY EVIDENCES PAYMENT OF THE LOCAL BUSINESS TAX PURSUANT TO CH. 205, FLORIDA STATUTES. IT DOES NOT PERMIT THE HOLDER TO OPERATE IN VIOLATIONS OF ANY CITY, STATE, OR FEDERAL LAW. CITY PERMITTING SERVICES IS NOTIFIED OF ANY VIOLATION. PERMITTING SERVICES WILL NOT REVENUE FROM THIS RECEIPT. THIS RECEIPT DOES NOT CONSTITUTE AN ENDORSEMENT OR APPROVAL OF THE HOLDER'S SKILL OR COMPETENCE.

Issued Date: 08/27/2016  
Expiration Date: 09/30/2017

**Business Name**  
BAXTER WINDOWS LLC  
102 DYERDEN RD  
SUITE 811-12  
ORLANDO, FL 32808

**Business Type(s):**  
CONTRACT GENERAL CONTRACTORS

License Number: BUS20160172

**Business Owner**  
BAXTER WINDOWS LLC  
102 DYERDEN RD  
SUITE 811-12  
ORLANDO, FL 32808

**Business Location**  
102 Dyerden Rd B  
Orlando, FL 32808

**Business Name**  
BAXTER WINDOWS LLC  
102 DYERDEN RD  
SUITE 811-12  
ORLANDO, FL 32808





# Baxter Windows

Energy Efficient Windows & Doors

102 Drennon Road Ste 511 & B12  
Orlando, FL 32806  
CGC 1522010

www.BaxterWindows.com  
Office: 407-930-1599  
Fax: 407-930-1598

Name: Jason Hunter

Phone H: \_\_\_\_\_

Phone C: 407-375-2470

Install Address: \_\_\_\_\_

5130 St Michael Ave

Email: \_\_\_\_\_

City, State, Zip: Belle Isle, FL 32812

Lead Source: Facebook

		Total			Total
	Simonton 73UI	\$256.00		Vinyl Wrap over wood	\$60.00
	Simonton 93UI	\$275.00		6 Labor, base on units removed	\$142.00
1	Simonton 101UI	\$280.00	\$280.00	Mulls (joining of multiple units)	\$88.00
5	Simonton 110UI	\$324.00	\$1,620.00	Glass Tempering per sash	\$86.00
	Simonton 130UI	\$338.00		Glass Tempering per Sq Ft.	\$32.00
	Simonton 132UI	\$396.00		Frosted/Obscured Glass	\$76.00
	Screens, Half or Full	\$38.00		Test for EPA Lead, pre 1978	\$10.00
	Simonton 5500 upgrade	\$89.00		EPA Lead Renovation per unit	\$80.00
6	Low E/Argon Gas, Energy Star 2015	\$132.00	\$792.00	Rotten Wood, Lineal Foot	\$65.00
	Trpl Pane/Krypton	\$285.00		Scaffolding, Per Floor/Level	\$170.00
	Laminated/Impact Glass	\$280.00		Interior Wood Caseing, Windows	\$165.00
	Colonial Grids	\$61.00		Interior Wood Casing, Doors	\$125.00
	Perimeter/Prairie Grids	\$80.00		Remove and Re-Install Blinds	\$15.00
	Beige Vinyl Solid Colour	\$76.00			
	Glass Tinting Grey/Bronze	\$70.00			
	Interior Wood Grain	\$132.00			
	Exterior Colors	\$282.00			
			Total	Total	
	Eyebrows/Half Round	\$		5'x6'8"	\$1,070.00
	Casement/Awning	\$		6'x6'8"	\$1,170.00
	Single Hung Eyebrow	\$		8'x6'8"	\$1,430.00
	Single Hung Half Round	\$		9'x6'8"	\$1,870.00
	Specialty Screens, Half or Full	\$ 42.00		12'x6'8"	\$2,851.00
	2 Lite Slider, Insulated Large	\$ 576.00		6'x8'	\$1,931.00
	2 Lite Slider, Insulated Small	\$434.00		8'x8'	\$2,171.00
	3 Lite Slider, Insulated Large	\$755.00		9'x8'	\$3,240.00
	3 Lite Slider, Insulated Small	\$508.00		12' x 8'	\$4,316.00
	Picture Window Large	\$466.00		Stackable SGD "List"	
	Picture Window Small	\$263.00		Origin Bifold Doors "List"	
	Grids, Colonial/Prairie	\$88.00		INOVO, Blinds, Per Panel (3' w only)	\$590.00
	Interior Wood Grain	\$186.00		Low E/Argon, Per Panel	\$210.00
	Low E <sup>2</sup> /Argon Gas, Energy Star	\$138.00		Removal & Install, Per Panel	\$240.00
	Laminated Glass "List"			Interior/Exterior Trim	\$235.00
	Beige Vinyl Solid Colour	\$144.00		Beige Vinyl	\$215.00
				Exterior Color (List \$)	
				Interior Woodgrain "List"	\$670.00
				Sliding Glass Door Screens	\$80.00

GLASS BREAKAGE WARRANTY AND FOAM WRAP IS INCLUDED ON ALL WINDOWS.

Total \$ \$3,544.00 Total

Stucco Cut-outs @ \$85 per unit removed

Permit & Fees \$ \$310.00

Total \$ \$3,854.00

Deposit 50% \$ \$1,927.00 Ck#

Balanced paid to installer upon completion \$ \$1,927.00

Screens included

Buyer acknowledges that he/she has read and understands all of the terms and conditions on the front and back of this contract.

Evan Portman 3/22/2017

Salesman Date

Copyright©2012, H. Nathan Meister

rev. v8.5

 22 Mar 17  
Date

# WINDOW MEASUREMENTS

NAME: Hunter      # OF STORIES: \_\_\_\_\_      DATE: 3/22/2017      # OF WINDOWS: \_\_\_\_\_  
 TYPE OF CONSTRUCTION: Concrete/Cinder Block      TYPE OF WINDOWS: \_\_\_\_\_

	SIZE(wxh)	MDL	IE	OBS	TP	GRID/PATTERNS	L/H	FS	SQ'	U.I
1	52	49 1/8	DH	LEE					17.740	101.125
2	47 1/4	58 7/8	DH	LEE					19.318	106.125
3	51 3/8	36 1/4	DH	LEE					12.933	87.625
4	47	59 1/8	DH	LEE					19.298	106.125
5	51 1/4	36 1/4	DH	LEE					12.901	87.500
6	47 3/8	59 1/4	DH	LEE					19.493	106.625
7	51 5/8	48 7/8	DH	LEE					17.522	100.500
8	51 1/2	48 7/8	DH	LEE					17.480	100.375
9	47 1/4	59 1/4	DH	LEE					19.441	106.500
10	51 3/8	48 5/8	DH	LEE					17.348	100.000
11										
12										
13										
14										
15										
16										
17										
18										
19										
20										
									173.474	

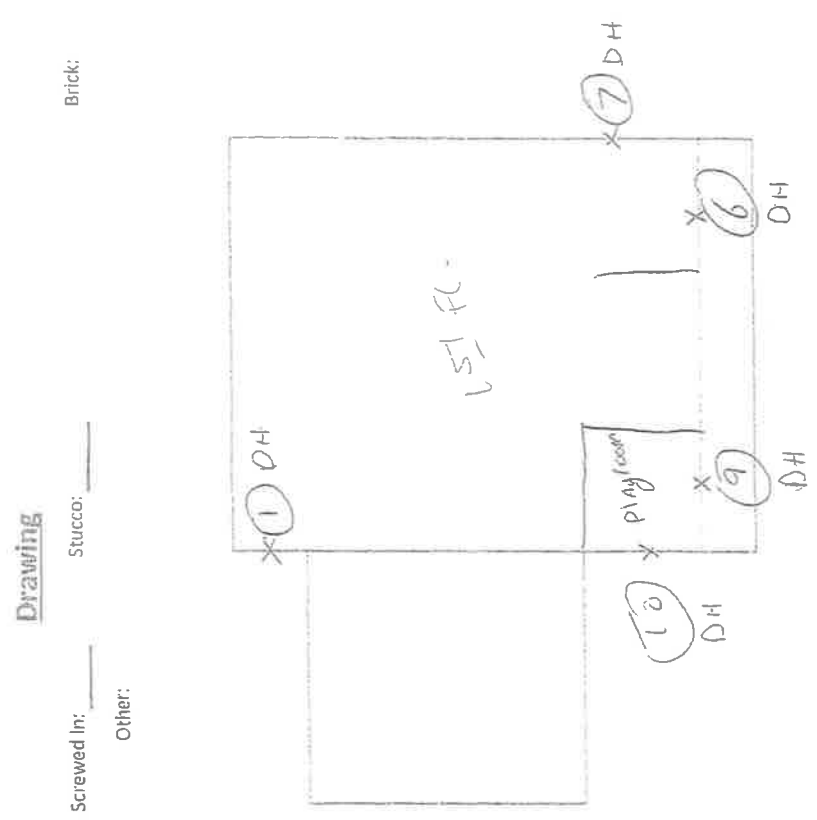

Now - 1, 2, 4, 6, 9, 10  
 -> xhunter@darden.com



# BUILDING DROPS

A Perfect Solution in Every Drop

Certificate of Authorization: 29578

398 East Dania Beach Blvd.  
Suite 338  
Dania Beach, FL 33004  
954.399.8478 PH  
954.744.4738 FX  
contact@buildingdrops.com

*of*  
**Simonton Windows**

*for*

**Florida Product Approval**

**5<sup>th</sup> Edition Florida Building Code  
Per Rule 61G20-3**

**Method: 1 – A (Certificate Method)**  
**Category: Windows**  
**Sub – Category: Double Hung**

**Product: Double Hung Series 75-75 / 07-75 / 75-09 /  
07-09 / 07-10 / 07-20 Vinyl Window**  
**Material: Poly Vinyl Chloride**  
**Product Dimensions: See Installation Instructions IN0132**

**Prepared For:**

**Prepared by:**

Florida Professional Engineer # 73778  
Date: 06/20/2015

Contents:

Evaluation Report Pages 1 – 4  
Digitally signed by Hermes F. Norero, P.E.  
Reason: I am approving this document  
Date: 2015.06.23 21:56:15 -04'00'



Hermes F. Norero, P.E.  
Florida No. 73778



# BUILDING DROPS

A Perfect Solution in Every Drop

Certificate of Authorization: 29578

FL#: FL5167  
Date: 06/20/2015  
Report No: 3821

---

**Manufacturer:** Simonton Windows

**Product Category:** Windows

**Product Sub-Category:** Double Hung

**Compliance Method:** State Product Approval Rule 61G20-3.005 (1)(a)

**Product Name:** Double Hung Series 75-75 / 07-75 / 75-09 / 07-09 / 07-10 / 07-20 Vinyl Window (Non-Impact)

**Scope:** This is a Product Evaluation Report issued by Hermes F. Norero, P.E. (FL # 73778) for Simonton Windows based on Rule Chapter No. 61G20-3.005, Method 1a of the State of Florida Product Approval, Florida Department of Business and Professional Regulation - Florida Building Commission.

Hermes F. Norero, P.E. does not have nor will acquire financial interest in the company manufacturing or distributing the product or in any other entity involved in the approval process of the product named herein.

This product has been evaluated for use in locations adhering to the 5<sup>th</sup> Edition Florida Building Code.

See Installation Instructions **IN0132** provided by manufacturer for specific use parameters.

#### Limits of Use:

1. This product has been evaluated and is in compliance with the 5<sup>th</sup> Edition Florida Building Code, excluding the "High Velocity Hurricane Zone" (HVHZ).
2. Product anchors shall be as listed and spaced as shown on details. Anchor embedment into substrate material shall be beyond wall dressing or stucco.
3. When used in areas requiring wind borne debris protection this product complies with Section 1609.1.2 of the 5<sup>th</sup> Edition Florida Building Code and does require an impact resistant covering.
4. Site conditions that deviate from the details of **IN0132** require further engineering analysis by a licensed engineer or registered architect.
5. See Installation Instructions **IN0132** for size and design pressure limitations.

Hermes F. Norero, P.E.  
Florida No. 73778  
Page 2 of 4



# BUILDING DROPS

A Perfect Solution in Every Drop

Certificate of Authorization: 29578

FL#: FL5167

Date: 06/20/2015

Report No: 3821

---

**Certification Agency:** The manufacturer has demonstrated compliance of products in accordance with the Florida Building Code and Rule 61G20-3 for manufacturing under a Certification Agency through **American Architectural Manufacturers Association (FBC Organization #: CER1498)**.

**Performance Standards:** The product described herein has been tested per:

- AAMA/WDMA/CSA 101/I.S.2/A440-08
- AAMA/WDMA/CSA 101/I.S.2/A440-05

**Referenced Data:**

1. Product Testing performed by **Architectural Testing – York, PA (FBC Organization # TST1558)**  
Report #: C2266.01-109-47      Report Date: 09/19/12  
Report #: D2914.01-109-47      Report Date: 01/10/14
2. Product Testing performed by **Architectural Testing – Springdale, PA (FBC Organization # TST7110)**  
Report #: A6989.01-501-47      Report Date: 04/26/11  
Report #: C9020.01-501-47      Report Date: 06/27/13  
Report #: C9025.01-501-47      Report Date: 07/03/13
3. Certification Agency  
**American Architectural Manufacturers Association (FBC Organization #: CER1498)**



# BUILDING DROPS

A Perfect Solution in Every Drop

Certificate of Authorization: 29578

FL#: FL5167

Date: 06/20/2015

Report No: 3821

**Installation:**

1. Approved anchor types and substrates are as follows:
  - A. For concrete (min.  $f'c=3000$  psi) or masonry (masonry shall comply with ASTM C90) substrate where one by (1X), non-structural, wood bucking is employed, use **3/16" diameter ITW Tapcon** type concrete screw anchors of sufficient length to achieve minimum embedment of 1.25" into concrete or masonry.
  - B. For concrete (min.  $f'c=3000$  psi) or masonry (masonry shall comply with ASTM C90) substrate where wood bucking is NOT employed, use **3/16" diameter ITW Tapcon** type concrete screw anchors of sufficient length to achieve minimum embedment of 1.25" into concrete or masonry.
  - C. For wood buck substrates (min. S.G.=0.55), use **#10 wood screw** type anchors of sufficient length to achieve minimum embedment of 1.5" into wood buck.

Refer to manufacturer Installation Instructions **IN0132** for anchor spacing and more details of the installation requirements.

**Design Pressure:**

SIZE CHART		
OVERALL SIZE		DP RATING
WIDTH "W"	HEIGHT "H"	
1/2"	80"	±35 PSF
1/2"	80"	±35 PSF
3/2"	74"	
5/2"	80"	±40 PSF
7/2"	80"	±50 PSF
8/2"	74"	

1. VALUE FOR W=74 SERIES ONLY

Hermes F. Norero, P.E.

Florida No. 73778

Page 4 of 4

(Validator / Operations Administrator)

**AAMA  
CERTIFICATION PROGRAM**



**AUTHORIZATION FOR PRODUCT CERTIFICATION**

Simonton Windows  
1 Cochrane Ave.  
Pennsboro, WV 26415

Attn: Tina Jenkins

The product described below is hereby approved for listing in the next issue of the AAMA Certified Products Directory. The approval is based on successful completion of tests, and the reporting to the Administrator of the results of tests, accompanied by related drawings, by an AAMA Accredited Laboratory.

1. The listing below will be added to the next published AAMA Certified Products Directory.

SPECIFICATION	RECORD OF PRODUCT TESTED			
AAMA/WDMA/CSA 101/I.S.2/A440-08 R-PG50*-914x1600 (36x63)-H				
COMPANY AND CODE	CPD NO.	SERIES MODEL & PRODUCT DESCRIPTION	MAXIMUM SIZE TESTED	
Simonton Windows Code: SIM	11048	75-75 DH (PVC)(X/X)(OG)(INS GL) (MODIF)(TILT)(ASTM)	<u>FRAME</u> 914 mm x 1600 mm (3'0" x 5'3")	<u>SASH</u> 832 mm x 778 mm (2'9" x 2'7")

2. This Certification will expire **June 7, 2017** and requires validation until then by continued listing in the current AAMA Certified Products Directory.

3. Product Tested and Reported by: **Architectural Testing, Inc.**

Report No.: C9020.01-501-47

Date of Report: **June 27, 2013**

Validated for Certification

Associated Laboratories, Inc.

Date: July 1, 2013

Authorized for Certification

Cc: AAMA  
JGS  
ACP-04 (Rev. 1/11)

American Architectural Manufacturers Association