



# City of Belle Isle

Universal Engineering Sciences 3532 Maggie Blvd., Orlando, FL 32811  
Tel 407-581-8161 \* Fax 407-581-0313 \* [www.universalengineering.com](http://www.universalengineering.com)

## PERMIT CARD - PLEASE POST AT JOB SITE

THIS DOCUMENT BECOMES YOUR PERMIT WHEN PROPERLY VALIDATED

Per FBC 105.3.3: An enforcing authority may not issue a building permit for any building construction, erection, alteration, modification, repair or addition unless the permit either includes on its face or there is attached to the permit the following statement: "NOTICE: In addition to the requirements of this permit, there may be additional restrictions applicable to this property that may be found in the public records of this county, and there may be additional permits required from other governmental entities such as water management districts, state agencies, or federal agencies." The issuance of this permit does not grant permission to violate any applicable City, Orange County, State of Florida, and/or Federal codes and/or ordinances. Separate permits are required for Signs, Roofing, Electrical, Gas, Plumbing and Mechanical services. This permit becomes VOID if the work authorized is not commenced within 6 months, or is suspended or abandoned for a period of 6 months after commencement. WORK SHALL BE CONSIDERED SUSPENDED IF AN APPROVED INSPECTION HAS NOT BEEN MADE WITHIN A 6 MONTH PERIOD. PERMISSION IS GRANTED TO DO THE FOLLOWING WORK ACCORDING TO THE CONDITIONS HEREON AND THE APPROVED PLANS AND SPECIFICATIONS, SUBJECT TO COMPLIANCE WITH THE ORDINANCES OF THE CITY OF BELLE ISLE, FLORIDA.

Scope of Work: RE-ROOF: 5130 sq ft metal

Comments: None

### Project Information

Address: 3537 Cullen Lake Shore Dr, Belle Isle, FL 32812

Parcel ID: 17-23-30-4391-20-840

Property Owner: Baker, Thomas

Phone Number: 407 561 1741

\*\*\*\*\*

Company Name: Prestige Metal Roofing

Contractor Name: McKinney, Gerald

License Number: 6061 Cinderlane Parkway, Orlando FL 32810

Phone Number: 407 290 6208

Permit Number: 2017-05-002

Date of Application: 04/25/2017

Date Permit Issued: 04/28/2017

**WARNING TO OWNER:** "YOUR FAILURE TO RECORD A NOTICE OF COMMENCEMENT MAY RESULT IN YOU PAYING TWICE FOR IMPROVEMENTS TO YOUR PROPERTY. IF YOU INTEND TO OBTAIN FINANCING, CONSULT WITH YOUR LENDER OR AN ATTORNEY BEFORE RECORDING YOUR NOTICE OF COMMENCEMENT." ON THE JOB INSPECTION(S) MUST BE MADE BEFORE PROCEEDING WITH SUBSEQUENT WORK. THIS CARD MUST BE DISPLAYED OUTSIDE AND BE PROTECTED FROM THE WEATHER WHILE BEING VISIBLE FROM THE STREET UNTIL THE FINAL INSPECTIONS HAVE BEEN APPROVED.

### BUILDING FEATURES

#### IMPACT FEES

School \$  
Traffic \$

#### ZONING FEES

Zoning Fee \$30.00

#### UNIVERSAL ENG - BUILDING FEES

Cert of Occ \$  
Demo \$  
Building \$  
Fence \$  
Driveway \$  
Shed \$  
Window(s) \$  
Door(s) \$  
PrePower \$  
Electrical \$  
Temp Pole \$  
Plumbing \$  
Mechanical \$  
Gas \$  
Roofing \$175.00  
Boat Dock \$  
Screen Encl \$  
Swimming Pool \$  
Sign \$

#### SURCHARGE FEES

Surcharge Fee \$2.63  
Surcharge Fee \$2.63

**TOTAL FEES \$210.26**

#### Date Paid

4-28-17

CC or Check # 1584 7141

Amount Paid 210.26

The person accepting this permit shall conform to the terms of the application on file and construction shall conform to the requirements of the Florida Building Code (FS 553).

#### BUILDING INSPECTOR USE ONLY

#### IF APPLICABLE:

Have Zoning Approval Conditions Been Met? YES NO Have Stormwater Approval Conditions Been Met? YES NO Silt fencing in place? YES NO Turbidity Barrier in place? YES NO

#### BUILDING

1<sup>st</sup>

(Footing/Foundation)

Survey specific foundation plan must be onsite before slab pour. Approved Plan on Site? \_\_\_\_\_

2<sup>nd</sup>

(Slab)

3<sup>rd</sup>

(Lintel)(Wall Reinforcing on Masonry Building)

4<sup>th</sup>

(Exterior Framing)(Roof/Wall Sheathing)

5<sup>th</sup>

(Framing) (To be made after Plumbing/Mechanical/Electrical Rough-Ins & Windows/Doors Installed)

6<sup>th</sup>

(Insulation to be Made After Roof Installed)

7<sup>th</sup>

(Drywall)

8<sup>th</sup>

(Sidewalk/Driveway)

9<sup>th</sup>

(Other)

10<sup>th</sup>

(Final - After MEP and Other Applicable Finals)

#### ROOFING

1<sup>ST</sup> ROOFING Deck Nailing/Dry-in/Flashing \_\_\_\_\_

2<sup>nd</sup> ROOFING Covering In-Progress \_\_\_\_\_

3<sup>rd</sup> ROOFING Covering Final \_\_\_\_\_

PLUMBING (Pool-Piping, Solar, Irrigation, Water Treatment Equip, Etc...)

1<sup>ST</sup> (Underground) 2<sup>nd</sup> (Sewer)

3<sup>rd</sup> (Rough-In/Tub Set) 4<sup>th</sup> (Final)

#### CHECK APPROPRIATE BOX

GAS  Natural  LP  MECHANICAL  ELECTRICAL  LOW VOLTAGE

1<sup>st</sup> (Rough-In) 2<sup>nd</sup> (Final)

Inspection requests are to be emailed to [BidScheduling@UniversalEngineering.com](mailto:BidScheduling@UniversalEngineering.com); a confirmation email will be sent back to you upon scheduling. Next-Day inspection requests must be made by 4pm. Please include the following in your request: Permit #, project address, type of inspection, date of the requested inspection, a contact name & a contact phone number. AM or PM may be requested but cannot be guaranteed.

For a copy of your permit, or to check inspection results, please visit <https://universalengineering.sharefile.com>  
login ID = [cobi@universalengineering.com](mailto:cobi@universalengineering.com) password = universal13



# City of Belle Isle

Universal Engineering Sciences 3532 Maggie Blvd., Orlando, FL 32809 \* **APR 25 2017**  
Tel 407-581-8161 \* Fax 407-581-0313 \* [www.universaleengineering.com](http://www.universaleengineering.com)

**RECEIVED**

## APPLICATION FOR ROOFING PERMIT

WARNING TO OWNER: YOUR FAILURE TO RECORD A NOTICE OF COMMENCEMENT MAY RESULT IN YOUR PAYING TWICE FOR IMPROVEMENTS TO YOUR PROPERTY. A NOTICE OF COMMENCEMENT MUST BE RECORDED AND POSTED ON THE JOB SITE BEFORE THE FIRST INSPECTION. IF YOU INTEND TO OBTAIN FINANCING, CONSULT WITH YOUR LENDER OR AN ATTORNEY BEFORE RECORDING YOUR NOTICE OF COMMENCEMENT.

DATE OF APPLICATION: \_\_\_\_\_ ROOF PERMIT NUMBER: 2017-05-008  
PLEASE PRINT. The undersigned hereby applies for a permit to make installations as indicated below:

Project Address 3537 CULLEN LAKE SHORE DR. Belle Isle, FL  32809  32812  
Property Owner THOMAS BAKER Phone 757-561-1791  
Property Owner's Mailing Address 5 CROSSLIN LN. City Bella Vista

State ARIZONA Zip Code 72714 Parcel Id Number: 17-23-30-4391-20-840  
REQUIRED! To obtain this information, please visit <http://www.ocpafl.org/Searches/ParcelSearch.aspx>

Class of Building: Old  New  Type of Building: Residential  Commercial  Other   
Type of Work: New Roof  ReRoof

- **REQUIRED!** Florida Product Approval Screen Printout from [www.floridabuilding.org](http://www.floridabuilding.org) showing the Code Version
- **REQUIRED!** Florida Product Approval Installation Instructions from [www.floridabuilding.org](http://www.floridabuilding.org) (not the manufacturer instructions)
- **REQUIRED!** Copies of your General Liability & Worker's Comp Insurance Certificate & State and Local Licenses

Please indicate the nature of work by completing the information below:

Roof Square Footage: 5130 Number of Stories: 2 Job Valuation: \$ 31,000

Type: Asphalt Shingles  Metal  Modified Bitumen  Other: \_\_\_\_\_

I hereby certify that the above is true and correct to the best of my knowledge and make Application for Permit as outlined above, and if same is granted I agree to conform to all Florida Building Code Regulations and City Ordinances regulating same and in accordance with plans submitted. The issuance of this permit does not grant permission to violate any applicable Town and/or State of Florida codes and/or ordinances. By signing below, I recognize Republic Services is by legal contract the sole authorized provider of garbage, recycling, yard waste, and commercial garbage and construction debris collection and disposal services with the city limits of the City. Contractors, homeowners and commercial businesses may contact Republic Services at 407-293-8000 to setup accounts for Commercial, Construction Roll Off, or other services needed. Rates are fixed by contract and are available at City Hall or from Republic Services. The City enforces the contract through its code enforcement office. Failure to comply will result in a stop work order.

LICENSE HOLDER SIGNATURE [Signature] LICENSE # CCC 033709  
LICENSE HOLDER NAME GERARD MCKINNEY COMPANY NAME Prestige Metal Roofing  
Street Address 6061 CINDERLAKE PKWY  
City Orlando State FL Zip Code 32810 Phone Number 407-290-6203  
Email Address MANAGER.PMR@CFL.RE.COM

Building Official: sq Date 4-28-17  
 Verified Contractor's Licenses & Insurance are on file [Signature] Date 4-28-17  
 NOCCU

Zoning Fee \$ 30.  
 Permit Fee \$ 175.-  
 Review Fee \$ 0  
 3% Florida Surcharge \$ 5.26  
 Total Permit Fee \$ 210.26

NOTE: The Building Permit Number is required if the Roof Installation is associated with any construction or alteration where a Building Permit has been issued.

2.63  
 2.63  
 5.26

15T 1K  
 30x5  
 175

AFTER RECORDING - RETURN TO:  
Prestige Metal Roofing Inc.  
8081 Cinderlane Pkwy # 100  
Orlando FL 32810



PERMIT NUMBER: \_\_\_\_\_  
Tax Folio No: \_\_\_\_\_ **NOTICE OF COMMENCEMENT**

The undersigned hereby given notice that improvement will be made to certain real property, and in accordance with Chapter 713.13 Florida Statutes, the following information is provided in the NOTICE OF COMMENCEMENT.

1. DESCRIPTION OF PROPERTY (Legal description & street address, if available) TAX FOLIO NO.: 17-23-30-4391-20-840  
SUBDIVISION Lake Conway Woods BLOCK B TRACT \_\_\_\_\_ LOT 8K BLDG \_\_\_\_\_ UNIT \_\_\_\_\_

3537 Cullen Lake Shore Dr. Delmas, Fl. 32822

2. GENERAL DESCRIPTION OF IMPROVEMENT: NEW METAL ROOF ON SFR

3. OWNER INFORMATION: a. Name THOMAS BAKER  
b. Address 3537 Cullen Lake Shore Dr. Belle Isle Fl c. Interest in property FREE SINGLE OWNER

d. Name and address of fee simple titleholder (if other than Owner)  
4. CONTRACTOR'S NAME, ADDRESS AND PHONE NUMBER:  
Gerald McKinney / Prestige Metal Roofing Inc. 407-290-6203  
8081 Cinderlane Pkwy # 100 Orlando FL 32810

5. SURETY'S NAME, ADDRESS AND PHONE NUMBER AND BOND AMOUNT:  
N/A

6. LENDER'S NAME, ADDRESS AND PHONE NUMBER:  
N/A

7. Identity of persons within the State of Florida designated by Owner upon whom notices or other documents may be served as provided by Section 713.13 (1) (a) 7, Florida Statutes:  
N/A NAME, ADDRESS AND PHONE NUMBER:

8. In addition to himself or herself, Owner designates the following to receive a copy of the Lienor's Notice as provided in Section 713.13 (1) (b), Florida Statutes:  
N/A NAME, ADDRESS AND PHONE NUMBER:

9. Expiration date of notice of commencement (the expiration date is 1 year from the date of recording unless a different date is specified): \_\_\_\_\_ 20\_\_\_\_

**WARNING TO OWNER: ANY PAYMENTS MADE BY THE OWNER AFTER THE EXPIRATION OF THE NOTICE OF COMMENCEMENT ARE CONSIDERED IMPROPER PAYMENTS UNDER CHAPTER 713, PART I SECTION 713.13, FLORIDA STATUTES, AND CAN RESULT IN YOUR PAYING TWICE FOR IMPROVEMENTS TO YOUR PROPERTY. A NOTICE OF COMMENCEMENT MUST BE RECORDED AND POSTED ON THE JOB SITE BEFORE THE FIRST INSPECTION. IF YOU INTEND TO OBTAIN FINANCING, CONSULT WITH YOUR LENDER OR AN ATTORNEY BEFORE COMMENCING WORK OR RECORDING YOUR NOTICE OF COMMENCEMENT.**

Verification pursuant to Section 92.525, Florida Statutes Under Penalties of perjury, I declare that I have read the foregoing and that the facts in it are true to the best of my knowledge and belief (Section 92.525, Florida Statutes).

TM Baker  
Signature of Owner or  
Owner's Authorized Officer/Director/Partner/Manager

THOMAS BAKER  
Print Name and Provide Signatory's Title/Office

State of Florida  
County of \_\_\_\_\_

The foregoing instrument was acknowledged before me this 24 day of March, 2017

By Thomas Baker as owner (type of authority... e.g. officer, trustee, attorney in fact)

For self (name of party on behalf of whom instrument was executed)

\_\_\_\_\_ Personally known or  produced the following type of identification: FDL

\_\_\_\_\_  
(Signature of Notary Public)



I hereby certify that this is a true copy of the document as reflected in the Official Records of FLORIDA, County of ORANGE  
BY: Thomas Baker  
PHIL DIAMOND, COUNTY COMPTROLLER  
DATED: 4/25/17

# PRESTIGE METAL ROOFING INC.

6061 Cinderlane Pkwy., #100  
Orlando, FL 32810  
(407) 290-6203  
Toll Free (888) 807-6511 Fax. (407) 290-6316  
www.MyMetalRoof.com

## LIMITED POWER OF ATTORNEY

Date 4-25-17

I hereby name and appoint Joseph Moore as an agent of Prestige Metal Roofing Inc. to be my lawful attorney-in-fact to act for me to apply for, receipt for, sign for and do all things necessary to this appointment for:

( ) All Permits and Applications submitted by this contractor.  
() Permit for: 3537 Cullen Lake Shore Dr.

Expiration Date for this Limited Power of Attorney: 4/4

License Holder Name: Gerald W. McKinney II

State License Numbers: CCC033709 & CGC058169

Signature: 

State of Florida  
County of Orange

The foregoing instrument was acknowledged before me this 25 day of April 2017, by Gerald W. McKinney II who is personally known to me and who did not take an oath.

  
Signature

\_\_\_\_\_  
Notary Name

Stamp:  



**City of Belle Isle**  
 Universal Engineering Sciences 3532 Maggie Blvd., Orlando, FL 32811  
 Tel 407-581-8161 \* Fax 407-581-0313 \* [www.universalsengineering.com](http://www.universalsengineering.com)

## Product Approval Form

DATE: \_\_\_\_\_ PERMIT # 2017-05-022  
 PROJECT ADDRESS 3537 Colleen Lake Shore Dr., Belle Isle, FL  32809  32812

As required by Florida Statue 553.842 and Florida Administrative Code 9B-72m, please provide the information and approval numbers of the building components listed below if they will be utilized on the building or structure. FL Approved products are listed online at [www.floridabuilding.org](http://www.floridabuilding.org) or can be obtained from the local product supplier. The following information must be turned in with permit application and available onsite for inspections:

1. This Product Approval Cover Sheet
2. Internet screen from [FloridaBuilding.org](http://FloridaBuilding.org) showing PA#, approval and code edition stamped
3. Manufacturer's Installation details from [FloridaBuilding.org](http://FloridaBuilding.org) and requirements for each product stamped

Product Type	Manufacturer	Model/Series	FL Product Approval #	Product Type	Manufacturer	Model/Series	FL Product Approval #
<b>EXTERIOR DOORS</b>							
Swinging				Sliding			
Sliding				Soffits			
Sectional/Rollup				Storefront			
Other				Glass Block			
				Other			
<b>WINDOWS</b>							
Single/Dbf Hung				Asphalt Shingles			
Horizontal Slider				Non Struct Metal	UNION	MASTER 210	20484.2
Casement				Roofing Tiles			
Fixed				Single Ply Roof			
Mullion				Other			
Skylights				UNDERLAYMENT	ALPHA PROTECA	ZEPEL	12512-1
Other							
<b>STRUCTURAL COMPONENTS</b>							
Wood Connectors				<b>OTHER</b>			
Wood Anchors							
Truss Plates							
Insulation Forms							
Lintels							
Other							

It is the applicant's responsibility to verify that specific products have been installed in accordance with their limitations and with the minimum required design pressures for the structure. Specific compliance will be verified during field inspections.

Applicant Signature \_\_\_\_\_ Date 4-25-17



**Product Approval**  
USER: Public User

[Product Approval Menu](#) > [Product or Application Search](#) > [Application List](#) > [Application Detail](#)

FL # **FL20484**  
 Application Type **New**  
 Code Version **2014**  
 Application Status **Approved**



Comments Archived  
 Product Manufacturer **UNION CORRUGATING COMPANY**  
 Address/Phone/Email **701 S. KING ST.  
 FAYETTEVILLE, NC 28301  
 (910) 483-0479 Ext 256  
 jstieby@unioncorrugating.com**

Authorized Signature **John Stieby  
 jstieby@unioncorrugating.com**

Technical Representative Address/Phone/Email  
 Quality Assurance Representative Address/Phone/Email

Category **Roofing**  
 Subcategory **Metal Roofing**

Compliance Method **Evaluation Report from a Florida Registered Architect or a Licensed Florida Professional Engineer**  
 Evaluation Report - Hardcopy Received

Florida Engineer or Architect Name who developed the Evaluation Report **Bala Sockalingam**  
 Florida License **PE-62240**  
 Quality Assurance Entity **Keystone Certifications, Inc.**  
 Quality Assurance Contract Expiration Date **12/31/2020**  
 Validated By **Yoosef Lavi, P.E.**  
 Validation Checklist - Hardcopy Received

Certificate of Independence [FL20484\\_RO\\_COI\\_CertificateIndependence.pdf](#)

Referenced Standard and Year (of Standard)  

Standard	Year
FM 4470	1992
UL 1897	2004
UL 580	2006

Equivalence of Product Standards Certified By

Sections from the Code

Product Approval Method

Method 1 Option D

Date Submitted 05/23/2016  
 Date Validated 05/23/2016  
 Date Pending FBC Approval 05/24/2016  
 Date Approved 08/17/2016

Summary of Products		
FL #	Model, Number or Name	Description
20484.1	5V	Min 26 ga., 24" wide through fastened panel over 15/32" thick plywood  <b>Installation Instructions</b> FL20484_R0_II_EvaluationReportC2088_1.pdf Verified By: Bala Sockalingam, P.E. 62240 Created by Independent Third Party: Yes  <b>Evaluation Reports</b> FL20484_R0_AE_EvaluationReportC2088_1.pdf Created by Independent Third Party: Yes
20484.2	MasterRib	Min 29 ga., 36" wide through fastened panel over 15/32" thick plywood or 7/16" thick OSB  <b>Installation Instructions</b> FL20484_R0_II_EvaluationReportC2088_2.pdf Verified By: Bala Sockalingam, P.E. 62240 Created by Independent Third Party: Yes  <b>Evaluation Reports</b> FL20484_R0_AE_EvaluationReportC2088_2.pdf Created by Independent Third Party: Yes
20484.3	MasterRib	Min 29 ga., 36" wide through fastened panel over 15/32" thick plywood  <b>Installation Instructions</b> FL20484_R0_II_EvaluationReportC2088_3.pdf Verified By: Bala Sockalingam, P.E. 62240 Created by Independent Third Party: Yes  <b>Evaluation Reports</b> FL20484_R0_AE_EvaluationReportC2088_3.pdf Created by Independent Third Party: Yes
20484.4	ML150	Max 16.5" wide, min 24 ga. steel standing seam panel over 15/32" thick plywood  <b>Installation Instructions</b> FL20484_R0_II_EvaluationReportC2088_4.pdf Verified By: Bala Sockalingam, P.E. 62240 Created by Independent Third Party: Yes  <b>Evaluation Reports</b> FL20484_R0_AE_EvaluationReportC2088_4.pdf Created by Independent Third Party: Yes
20484.5	SL175	Max 18" wide, min 24 ga., snap-lock standing seam metal panel over 15/32" thick plywood  <b>Installation Instructions</b> FL20484_R0_II_EvaluationReportC2088_5.pdf Verified By: Bala Sockalingam, P.E. 62240 Created by Independent Third Party: Yes  <b>Evaluation Reports</b> FL20484_R0_AE_EvaluationReportC2088_5.pdf Created by Independent Third Party: Yes
		<b>Limits of Use</b> Approved for use in HVHZ: No Approved for use outside HVHZ: Yes Impact Resistant: N/A Design Pressure: +N/A/-93.5 Other: Uplift load of 39.8 psf @ clip spacing of 36" o.c. and 78.6 psf @ clip spacing of 8" o.c with felt. Uplift load of 93.5 psf @ clip spacing of 12" o.c. with self-adhering membrane.
		<b>Limits of Use</b> Approved for use in HVHZ: No Approved for use outside HVHZ: Yes Impact Resistant: N/A Design Pressure: +N/A/-88.5 Other: Uplift load of 56 psf for Fastening System 1. Uplift load of 88.5 psf for Fastening System 2.
		<b>Limits of Use</b> Approved for use in HVHZ: No Approved for use outside HVHZ: Yes Impact Resistant: N/A Design Pressure: +N/A/-84 Other: Uplift load of 52.5 psf @ clip spacing of 24" o.c. and 84.0 psf @ clip spacing of 6" o.c.

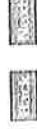

Contact Us :: 2601 Blair Stone Road, Tallahassee, FL 32399 Phone: 850-487-1824

The State of Florida is an AA/EEO employer. Copyright 2007-2013 State of Florida. :: Privacy Statement :: Accessibility Statement :: Refund Statement

Under Florida law, email addresses are public records. If you do not want your e-mail address released in response to a public-records request, do not send electronic mail to this entity. Instead, contact the office by phone or by traditional mail. If you have any questions, please contact 850.487.1395. \*Pursuant to Section 455.275(1), Florida Statutes, effective October 1, 2012, licensees licensed under Chapter 455, F.S. must provide the Department with an email address if they have one. The emails provided may be used for official communication with the licensee. However, email addresses are public record. If you do not wish to supply a personal address, please provide the Department with an email address which can be made available to the public. To determine if you are a licensee under Chapter 455, F.S., please click [here](#).

Product Approval Accepts:



Credit Card  
**Safe**

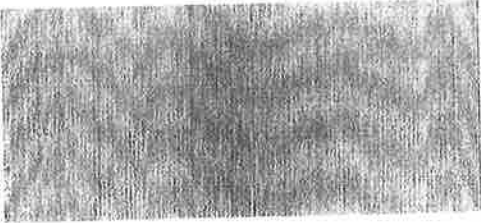

EVALUATION REPORT OF  
UNION CORRUGATING COMPANY  
'29 GA. MASTERRIB PANEL'

FLORIDA BUILDING CODE 5<sup>TH</sup> EDITION (2014)  
FLORIDA PRODUCT APPROVAL  
FL 20484.2  
ROOFING  
METAL ROOFING

Prepared For:  
Union Corrugating Company  
P. O. Box 229  
Fayetteville, NC 28302  
Telephone: (910) 483-0479  
Fax: (910) 483-8897

Prepared By:  
Bala Sockalingam, Ph.D., P.E.  
Florida Professional Engineer #62240  
1216 N Lansing Ave., Suite C  
Tulsa, OK 74106  
Telephone: (918) 492-5992  
FAX: (866) 366-1543

This report consists of  
Evaluation Report (3 Pages including cover)  
Installation Details (1 Page)  
Load Span Table (1 Page)

Report No. C2088-2  
Date: 5.23.16

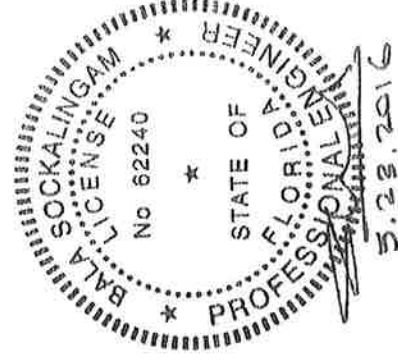

Manufacturer: Union Corrugating Company

Product Name: MasterRib Panel

Panel Description: 36" wide coverage with 3/4" high ribs at 9" o.c.

Materials: Minimum 29 ga., 80 ksi steel. Galvanized coated steel (ASTM A653) or Galvalume coated steel (ASTM A792) or painted steel (ASTM A755).

Deck Description: Min. 7/16" thick OSB or min. 15/32" thick APA rated plywood or min. 3/4" thick wood plank (min SG of 0.42) for new and existing constructions. Designed by others and installed as per FBC 2014.

New Underlayment: Minimum underlayment as per FBC 2014 Section 1507.4.5.1. Required for new construction.

Existing Underlayment: (Optional) One layer of asphalt shingles over one layer of #30 felt. For reroofing construction only.

Slope: 1/2:12 or greater in accordance with FBC 2014 Section 1507.4.2

Design Uplift Pressure: (Factor of Safety = 2) 56.0 psf @ fastener spacing of 24" o.c.  
124.0 psf @ fastener spacing of 6" o.c.

Panel Attachment: #10-15 x 1.5" long wood screw with washer  
At interior @ 9" o.c. across panel width  
At panel ends @ 5.5"-3.5"-5.5" o.c. across panel width

Sidelap Attachment: (Optional) 1/4"-14 x 7/8" long SDS with washer @ max 24" o.c.

Test Standards: Roof assembly tested in accordance with UL580-06 'Uplift Resistance of Roof Assemblies' & UL1897-04 'Uplift Tests for Roof Covering Systems' and FM 4470 Section 5.5 'Resistance to Foot Traffic'.

Code Compliance: The product described herein has demonstrated compliance with FBC 2014 Section 1507.4

Product Limitations: Design wind loads shall be determined for each project in accordance with FBC 2014 Section 1609 or ASCE 7-10 using allowable stress design. The maximum fastener spacing listed herein shall not be exceeded. The design pressure for reduced fastener spacing may be computed using rational analysis prepared by a Florida Professional Engineer or based on Union load span table. This evaluation report is

not applicable in High Velocity Hurricane Zone. Refer to current NOA for use of this product in High Velocity Hurricane Zone. Fire classification is not within scope of this Evaluation Report. Refer to FBC 2014 Section 1505 and current approved roofing materials directory or ASTM E108/UL790 report from an accredited laboratory for fire ratings of this product.

Supporting Documents:

UL580 & UL1897 Test Reports  
Farabaugh Engineering and Testing Inc  
Project No. T198-16, Reporting Date 5/16/16

FM 4470 Test Report  
ENCON Technology Inc.  
C1583-2, Reporting Date 7/24/08

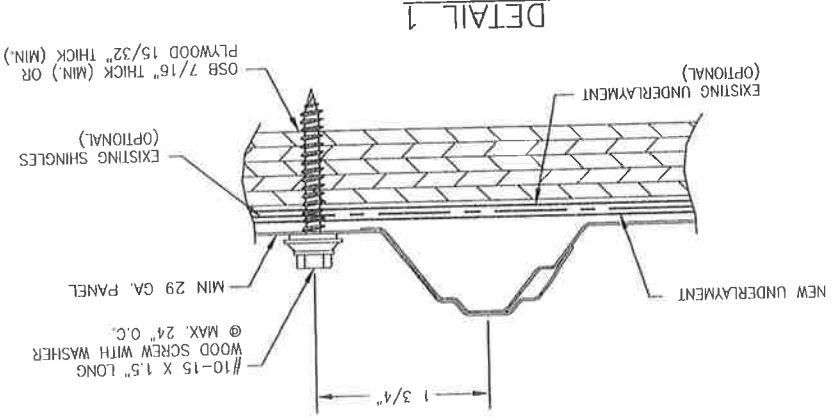

TYPICAL PANEL INSTALLATION X-SECTION

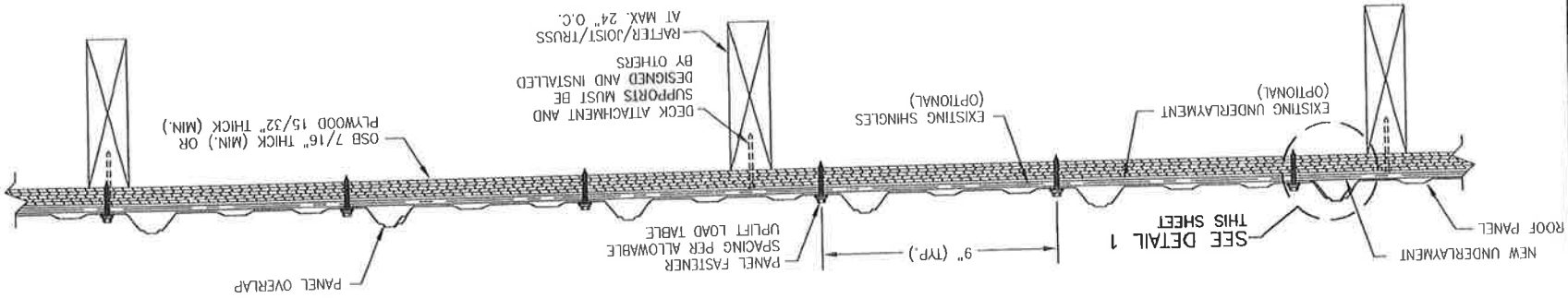

- GENERAL NOTES:**
1. ARCHITECTURAL ROOF PANEL HAS BEEN DESIGNED IN ACCORDANCE WITH THE FLORIDA BUILDING CODE (FBC).
  2. ROOF PANELS SHALL BE MINIMUM 29 GA. EFFECTIVE COVERING WIDTH OF PANEL = 36".
  3. THE ROOF PANELS SHALL BE INSTALLED OVER SHEATHING & STRUCTURE AS SPECIFIED ON THIS DRAWING.
  4. REQUIRED DESIGN WIND LOADS SHALL BE DETERMINED FOR EACH PROJECT. THIS PANEL SYSTEM MAY NOT BE INSTALLED WHEN THE REQUIRED DESIGN WIND LOADS ARE GREATER THAN THE ALLOWABLE WIND LOAD TABLE.
  5. ALL FASTENERS MUST BE IN ACCORDANCE WITH THIS DRAWING & THE FLORIDA BUILDING CODE. IF A DIFFERENCE OCCURS BETWEEN THE MINIMUM REQUIREMENTS OF THIS DRAWING & THE CODE, THE CODE SHALL CONTROL.
  6. RAFTERS/JOISTS/TRUSSES MUST BE DESIGNED TO WITHSTAND WIND LOADS AS REQUIRED FOR EACH APPLICATION AND ARE THE RESPONSIBILITY OF OTHERS.

DRAWING TITLE  
MASTER RIB PANEL

CONSULTANTS  
BALA SOCKALINGAM, PH.D., P.E.  
1216 N. LANSING AVE. SUITE C  
TULSA, OK 74108  
PHONE: 918-492-9992 FAX: 906-366-1543

MANUFACTURER  
UNION CORRUGATING CO.  
701 S. KING STREET  
FAYETTEVILLE, NC 28301  
910-483-2195

NO.	REVISION DESCRIPTION	BY	DATE

PLG: 5/23/18  
DATE: 5/23/18  
J.S.  
CHECKED BY: J.S.  
DRAWN BY: J.S.

DRAWING NO. REV.  
C2088-2  
SHEET NO. 1  
OF 1

**UNION CORRUGATING COMPANY**  
**MasterRib Panel Uplift Loads**  
**(Min 29 ga.)**

Description	Fastener Spacing along Panel Length (in)	Allowable Uplift Load (psf)
Coverage width: 36"	<b>6</b>	<b>124.0</b>
Panel Fasteners #10-15 hex head screws with sealed washer	8	116.4
	10	108.9
	12	101.3
	14	93.8
Panel fasteners spaced at 9" o.c. across panel width	16	84.0
	18	74.7
	20	67.2
	22	61.1
	<b>24</b>	<b>56.0</b>

**Notes:**

1. The bold numbers indicate design loads calculated from test data with safety factor of 2.
2. Panels must be installed as per Evaluation Report FL 20484.2 and Union current installation procedure.

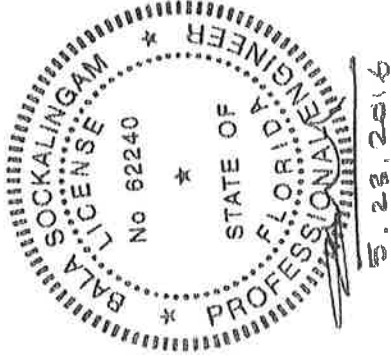

1216 N Lansing Ave., Suite C  
Tulsa, Ok 74106  
918 492 5992

Bala Sockalingam, Ph.D., P.E.  
FL 62240

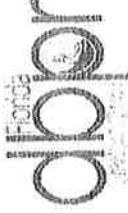

**Product Approval**  
USER: Public User

[Product Approval Menu](#) > [Product or Application Search](#) > [Application List](#) > [Application Detail](#)

FL #	FL12512-R4
Application Type	Revision
Code Version	2014
Application Status	Approved
Comments	Reviewed for Code Compliance Universal Engineering Sciences
Archived	
Product Manufacturer	AlphaProTech Engineered Products, Inc.
Address/Phone/Email	301 S. Blanchard St. Valdosta, GA 31601 (229) 242-1931 bhayden@alphaprotech.com
Authorized Signature	Bruce Hayden bhayden@alphaprotech.com
Technical Representative	Bruce Hayden
Address/Phone/Email	301 S. Blanchard St. Valdosta, GA 31601 (229) 242-1931 bhayden@alphaprotech.com
Quality Assurance Representative	Daniel LaFace
Address/Phone/Email	301 South Blanchard Street Valdosta, GA 31601 (229) 242-1931 Ext 237 dlaface@alphaprotech.com
Category	Roofing
Subcategory	Underlayments
Compliance Method	Evaluation Report from a Florida Registered Architect or a Licensed Florida Professional Engineer <input checked="" type="checkbox"/> Evaluation Report - Hardcopy Received
Florida Engineer or Architect Name who developed the Evaluation Report	Zachary R. Priest
Florida License	PE-74021
Quality Assurance Entity	TI RADCO LLP dba RADCO A Twining Company
Quality Assurance Contract Expiration Date	07/02/2019
Validated By	Locke Bowden <input checked="" type="checkbox"/> Validation Checklist - Hardcopy Received
Certificate of Independence	<a href="#">FL12512_R4_COI_APT15001.1_2014_FBC_Underlayments_ESS.pdf</a>
Referenced Standard and Year (of Standard)	
Equivalence of Product Standards Certified By	

Sections from the Code

- 1507.2.3
- 1507.3.3
- 1507.5.3
- 1507.7.3
- 1507.8.3
- 1507.9.3

Product Approval Method

Method 2 Option B

- Date Submitted 06/23/2015
- Date Validated 06/24/2015
- Date Pending FBC Approval 06/30/2015
- Date Approved 08/19/2015

**Summary of Products**

FL #	Model, Number or Name	Description
12512.1	REX SynFelt Synthetic Roof Underlayment	Synthetic Roof Underlayment
<p><b>Limits of Use</b>                      Approved for use in HVHZ: No                      Approved for use outside HVHZ: Yes                      Impact Resistant: N/A                      Design Pressure: N/A                      Other: See evaluation report for limits of use.</p>		
12512.2	REXtreme Synthetic Roof Underlayment	Synthetic Roof Underlayment
<p><b>Limits of Use</b>                      Approved for use in HVHZ: No                      Approved for use outside HVHZ: Yes                      Impact Resistant: N/A                      Design Pressure: N/A                      Other: See evaluation report for limits of use.</p>		
12512.3	TECHNO SB Synthetic Roof Underlayment	Synthetic Roof Underlayment
<p><b>Limits of Use</b>                      Approved for use in HVHZ: No                      Approved for use outside HVHZ: Yes                      Impact Resistant: N/A                      Design Pressure: N/A                      Other: See evaluation report for limits of use.</p>		
12512.4	TECHNOply Synthetic Roof Underlayment	Synthetic Roof Underlayment
<p><b>Limits of Use</b>                      Approved for use in HVHZ: No                      Approved for use outside HVHZ: Yes                      Impact Resistant: N/A                      Design Pressure: N/A                      Other: See evaluation report for limits of use.</p>		



Contact Us :: 2601 Blair Stone Road, Tallahassee FL 32399 Phone: 850-487-1824

The State of Florida is an AA/EEO employer. Copyright 2007-2013 State of Florida. :: [Privacy Statement](#) :: [Accessibility Statement](#) :: [Refund Statement](#)

Under Florida law, email addresses are public records. If you do not want your e-mail address released in response to a public-records request, do not send electronic mail to this entity. Instead, contact the office by phone or by traditional mail. If you have any questions, please contact 850.487.1395. \*Pursuant to Section 455.275(1), Florida Statutes, effective October 1, 2012, licensees licensed under Chapter 455, F.S. must provide the Department with an email address if they have one. The emails provided may be used for official communication with the licensee. However email addresses are public record. If you do not wish to supply a personal address, please provide the Department with an email address which can be made available to the public. To determine if you are a licensee under Chapter 455, F.S., please click [here](#).

Product Approval Accepts:



Credit Card

Safe





# CREEK TECHNICAL SERVICES, LLC

Certificate of Authorization No. 29824  
17520 Edinburgh Drive  
Tampa, FL 33647  
(813) 480-3421

## EVALUATION REPORT

FLORIDA BUILDING CODE 5<sup>TH</sup> EDITION (2014)

### Manufacturer:

ALPHA PROTECH ENGINEERED PRODUCTS, INC.  
301 South Blanchard Street  
Valdosta, GA 31601  
(229) 242-1931  
<http://www.alphaotech.com>

Issued June 22, 2015

### Manufacturing Locations:

Valdosta, GA

### Quality Assurance:

RADCO, Inc. (QUA1990)

## SCOPE

### Category:

Roofing

### Subcategory:

Underlayments

### Code Sections:

1507.2.3, 1507.3.3, 1507.5.3, 1507.7.3, 1507.8.3, 1507.9.3

### Properties:

Physical properties

## REFERENCES

Entity	Report No.	Standard	Year
PRI Construction Materials Technologies (TST5878)	AEP-017-02-01	ASTM D 226	2006
RADCO, Inc (TST1987)	RAD-5212	ASTM D 4869	2005e1
Ramtech Laboratories, Inc. (TST6127)	13075-04-08	AC 188	2012
		AC 188	2012

## PRODUCT DESCRIPTION

### REX™ SynFelt

A mechanically attached, woven polypropylene underlayment (nominal weight = 2.56 lb/100ft<sup>2</sup>) used as an alternative to ASTM D 226, Type I and Type II roofing underlayments,

### REXtreme

A mechanically attached, woven polypropylene underlayment (nominal weight = 2.97 lb/100ft<sup>2</sup>) used as an alternative to ASTM D 226, Type I and Type II roofing underlayments

### TECHNOply

A mechanically attached, woven polypropylene underlayment (nominal weight = 2.05 lb/100ft<sup>2</sup>) used as an alternative to ASTM D 226, Type I and Type II roofing underlayments

### TECHNO SB

A mechanically attached, woven polypropylene underlayment (nominal weight = 2.00 lb/100ft<sup>2</sup>) used as an alternative to ASTM D 226, Type I and Type II and ASTM D 4869, Type II and IV roofing underlayments

## APPLICATION INSTRUCTIONS

### Deck Type:

The roof deck shall be constructed of closely fitted, solid sheathing for new or existing construction. Sheathing shall be installed in accordance with FBC requirements. Roof decks shall have no more than 1/8" gap at abutting joints.

### Min. slope:

2:12. For slopes less than 4:12, the underlayment must be half-lapped a full 24" over the underlying course.

### Attachment method:

Underlayment shall be attached in accordance with the FBC and manufacturer's installation instructions. At minimum, mechanically fastened with min. 12 ga. corrosion resistant ring shank nail with min. 1-inch diameter corrosion resistant round cap to a min. 3/4-inch penetration, 8" o.c. at side and end laps and 24" o.c in a staggered pattern along the center lines printed on the sheet. The side laps shall be a minimum 3" wide

APT15001.1

FL12512-R4

Page 1 of 2

This evaluation report is provided for State of Florida product approval under Rule 61G20-3. The manufacturer shall notify CREEK Technical Services, LLC of any product changes or quality assurance changes throughout the duration for which this report is valid. This evaluation report does not express nor imply warranty, installation, recommended use, or other product attributes that are not specifically addressed herein.



and minimum 6" wide at the end laps. The underlayment is installed starting at the eave, with the length of the roll parallel to the eave with the printed side facing up. All side laps shall be installed to shed water from the deck.

Allowable roof coverings: Asphalt shingles, slate shingles, clay and concrete tiles, metal roof panels and shingles, wood shakes and shingles

**LIMITATIONS**

- 1) This evaluation report is not for use in the HVHZ.
- 2) Fire Classification is not within the scope of this evaluation.
- 3) Wind uplift resistance is not within the scope of this evaluation.
- 4) Installation of the evaluated product shall comply with this report, the FBC, and the manufacturer's published application instructions. Where discrepancies exist between these sources, the more restrictive and FBC compliant installation detail shall prevail.
- 5) Deck substrates shall be clean, dry, and free from any irregularities and debris. All fasteners in the deck shall be checked for protrusion and corrected prior to underlayment application.
- 6) The roof deck shall be constructed of closely fitted sheathing for new or existing construction. Roof deck shall be installed in accordance with FBC requirements.
- 7) Unless otherwise stated, the minimum roof slope shall be in accordance with FBC requirements.
- 8) All underlayments shall be installed with the roll length parallel to the eave, starting at the eave, and lapped in success courses installed up the deck in a manner that effectively sheds water from the deck. End laps shall be staggered between courses in accordance with the manufacturer's application instructions.
- 9) Contact the manufacturer when installing at temperatures below the minimum application temperature.
- 10) The underlayment may be used as described in other current FBC product approval documents.
- 11) Roof coverings shall not be adhered directly to the underlayment. Roof coverings shall be mechanically fastened through the underlayment to the roof deck.
- 12) The underlayment shall be exposed on the roof deck for a maximum 30 days unless otherwise stated.
- 13) All products listed in this report shall be manufactured under a quality assurance program in compliance with Rule 61G20-3.

**COMPLIANCE STATEMENT**

The products evaluated herein by Zachary R. Priest, P.E. have demonstrated compliance with the Florida Building Code 5<sup>th</sup> Edition (2014) as evidenced in the referenced documents submitted by the named manufacturer.



2015.06.2  
2 13:55:44  
-04'00'

Zachary R. Priest, P.E.  
Florida Registration No. 74021  
Organization No. ANE9641

**CERTIFICATION OF INDEPENDENCE**

CREEK Technical Services, LLC does not have, nor will it acquire, a financial interest in any company manufacturing or distributing products under this evaluation.  
CREEK Technical Services, LLC is not owned, operated, or controlled by any company manufacturing or distributing products under this evaluation.  
Zachary R., Priest, P.E. does not have, nor will acquire, a financial interest in any company manufacturing or distributing products under this evaluation.  
Zachary R., Priest, P.E. does not have, nor will acquire, a financial interest in any other entity involved in the approval process of the product.

**END OF REPORT**  
FL12512-R4

APT15001.1

This evaluation report is provided for State of Florida product approval under Rule 61G20-3. The manufacturer shall notify CREEK Technical Services, LLC of any product changes or quality assurance changes throughout the duration for which this report is valid. This evaluation report does not express nor imply warranty, installation, recommended use, or other product attributes that are not specifically addressed herein.



Searches    
  Sales Search    
  Results    
  Property Record Card    
  My Favorites

**3537 Cullen Lake Shore Dr** < 17-23-30-4391-20-840 >

Baker Thomas Maxwell  
 Baker Dana Marie  
 5 Croglin Ln  
 Bella Vista, AR 72714-1830  
 incorrect Mailing Address?  
 3537 Cullen Lake Shore Dr  
 Orlando, FL 32812  
 0103 - Single Fam Class III  
 Belle Isle

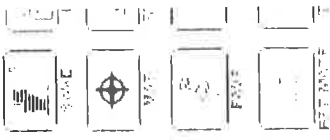

**Property Description**

LAKE CONWAY WOODS 4/41 LOT 84 BLK B SEE 4927/838

**Total Land Area**     13,780 sqft (+/-)     |     0.32 acres (+/-)     GIS Calculated     Notice

**Land**

Land Use Code	Zoning	Land Units	Unit Price	Land Value
0130 - Sfr - Lake Front	R-1-AA	1 LOT(S)	working...	working...

Page 1 of 1 (1 total records)

**Buildings**

Important Information		Structure	
<b>Model Code:</b>	01 - Single Fam Residence	<b>Actual Year Built:</b>	2004
<b>Type Code:</b>	0103 - Single Fam Class III	<b>Beds:</b>	5
<b>Building Value:</b>	working...	<b>Baths:</b>	4.0
<b>Estimated New Cost:</b>	working...	<b>Floors:</b>	2

Page 1 of 1 (1 total records)

**Extra Features**

Description	Date Built	Ur
BD3 - Boat Dock 3	10/14/2004	11



# CERTIFICATE OF LIABILITY INSURANCE

DATE (MM/DD/YYYY)  
08/19/2016

<b>PRODUCER</b> Jack Fields Agency (407)870-5534 (407)870-9491 FAX 10 E Monument St. Kissimmee, FL 34741	THIS CERTIFICATE IS ISSUED AS A MATTER OF INFORMATION ONLY AND CONFERS NO RIGHTS UPON THE CERTIFICATE HOLDER. THIS CERTIFICATE DOES NOT AMEND, EXTEND OR ALTER THE COVERAGE AFFORDED BY THE POLICIES BELOW.
<b>INSURERS AFFORDING COVERAGE</b> INSURER A: Endurance Insurance Co INSURER B: INSURER C: INSURER D: INSURER E:	NAIC #
<b>INSURED</b> Prestige Metal Roofing, Inc. License# CCC033709, CGG058169 6061 Cinderlane Pkwy #100 Orlando, FL 32810	

**COVERAGES**

INSR / ADD'L LTR (INSR)	TYPE OF INSURANCE	POLICY NUMBER	POLICY EFFECTIVE DATE (MM/DD/YYYY)	POLICY EXPIRATION DATE (MM/DD/YYYY)	LIMITS
A	GENERAL LIABILITY <input checked="" type="checkbox"/> COMMERCIAL GENERAL LIABILITY <input type="checkbox"/> CLAIMS MADE <input checked="" type="checkbox"/> OCCUR <input type="checkbox"/> <input type="checkbox"/> GEN'L AGGREGATE LIMIT APPLIES PER: <input checked="" type="checkbox"/> POLICY <input type="checkbox"/> PROJECT <input type="checkbox"/> LOC	CBC20000698400	08/27/2016	08/27/2017	EACH OCCURRENCE \$ 1,000,000 DAMAGE TO RENTED PREMISES (Per occurrence) \$ 100,000 MED EXP (Any one person) \$ 5,000 PERSONAL & ADV INJURY \$ 1,000,000 GENERAL AGGREGATE \$ 2,000,000 PRODUCTS - COM/PO/ AGG \$ 2,000,000
	AUTOMOBILE LIABILITY <input type="checkbox"/> ANY AUTO <input type="checkbox"/> ALL OWNED AUTOS <input type="checkbox"/> SCHEDULED AUTOS <input type="checkbox"/> HIRED AUTOS <input type="checkbox"/> NON-OWNED AUTOS				COMBINED SINGLE LIMIT \$ BODILY INJURY (Per person) \$ BODILY INJURY (Per accident) \$ PROPERTY DAMAGE (Per accident) \$
	GARAGE LIABILITY <input type="checkbox"/> ANY AUTO				AUTO ONLY - EA ACCIDENT \$ OTHER THAN AUTO ONLY: EA ACC \$ AGG \$
	EXCESS/UMBRELLA LIABILITY <input type="checkbox"/> OCCUR <input type="checkbox"/> CLAIMS MADE <input type="checkbox"/> DEDUCTIBLE <input type="checkbox"/> RETENTION \$				EACH OCCURRENCE \$ AGGREGATE \$ \$ \$ \$ \$
	WORKERS COMPENSATION AND EMPLOYERS' LIABILITY ANY PROPRIETOR/PARTNER/EXECUTIVE OFFICER/MEMBER EXCLUDED? If yes, describe under SPECIAL PROVISIONS below				<input type="checkbox"/> WC STATUTORY LIMITS <input type="checkbox"/> OTHER E.L. EACH ACCIDENT \$ E.L. DISEASE - EA EMPLOYEE \$ E.L. DISEASE - POLICY LIMIT \$
	OTHER				

**DESCRIPTION OF OPERATIONS / LOCATIONS / VEHICLES / EXCLUSIONS ADDED BY ENDORSEMENT / SPECIAL PROVISIONS**  
 Gerald McKinney II as Qualifying Contractor

**CERTIFICATE HOLDER**

City of Belle Isle  
 1600 Neta Ave.  
 Belle Isle, FL 32809  
 407-581-0313 Fax

**CANCELLATION**

SHOULD ANY OF THE ABOVE DESCRIBED POLICIES BE CANCELLED BEFORE THE EXPIRATION DATE THEREOF, THE ISSUING INSURER WILL ENDEAVOR TO MAIL 10 DAYS WRITTEN NOTICE TO THE CERTIFICATE HOLDER NAMED TO THE LEFT, BUT FAILURE TO DO SO SHALL IMPOSE NO OBLIGATION OR LIABILITY OF ANY KIND UPON THE INSURER, ITS AGENTS OR REPRESENTATIVES.

AUTHORIZED REPRESENTATIVE  
 John A Fields



JEFF ATWATER  
CHIEF FINANCIAL OFFICER

STATE OF FLORIDA  
DEPARTMENT OF FINANCIAL SERVICES  
DIVISION OF WORKERS' COMPENSATION

**\*\* CERTIFICATE OF ELECTION TO BE EXEMPT FROM FLORIDA WORKERS' COMPENSATION LAW \*\***

**CONSTRUCTION INDUSTRY EXEMPTION**

This certifies that the individual listed below has elected to be exempt from Florida Workers' Compensation law.

**EFFECTIVE DATE:** 10/10/2016

**EXPIRATION DATE:** 10/10/2018

**PERSON:** MCKINNEY

GERALD W II

**FEIN:** 593649569

**BUSINESS NAME AND ADDRESS:**

PRESTIGE METAL ROOFING, INC.

6061 CINDERLANE PKWY #100

ORLANDO FL 32810

**SCOPES OF BUSINESS OR TRADE:**

LICENSED GENERAL CONTRACTOR  
LICENSED ROOFING CONTRACTOR

Pursuant to Chapter 440.05(14), F.S., an officer of a corporation who elects exemption from this chapter by filing a certificate of election under this section may not recover benefits or compensation under this chapter. Pursuant to Chapter 440.05(12), F.S., Certificates of election to be exempt... apply only within the scope of the business or trade listed on the notice of election to be exempt. Pursuant to Chapter 440.05(13), F.S., Notices of election to be exempt and certificates of election to be exempt shall be subject to revocation if, at any time after the filing of the notice or the issuance of the certificate, the person named on the notice or certificate no longer meets the requirements of this section for issuance of a certificate. The department shall revoke a

DFS-F2-DWC-252 CERTIFICATE OF ELECTION TO BE EXEMPT REVISED 08-13

QUESTIONS? (850)413-1609

RICK SCOTT, GOVERNOR

KEN LAWSON, SECRETARY

STATE OF FLORIDA  
DEPARTMENT OF BUSINESS AND PROFESSIONAL REGULATION  
CONSTRUCTION INDUSTRY LICENSING BOARD



LICENSE NUMBER	
CGC059169	

The GENERAL CONTRACTOR  
Named below IS CERTIFIED  
Under the provisions of Chapter 489 FS.  
Expiration date: AUG 31, 2018



MC KINNEY, GERALD W/II  
PRESTIGE METAL ROOFING INC  
6061 CINDERLANE PARKWAY  
SUITE 100  
ORLANDO FL 32810

ISSUED: 07/20/2016      DISPLAY AS REQUIRED BY LAW      SEQ # L1607200001170

RICK SCOTT, GOVERNOR

KEN LAWSON, SECRETARY

STATE OF FLORIDA  
DEPARTMENT OF BUSINESS AND PROFESSIONAL REGULATION  
CONSTRUCTION INDUSTRY LICENSING BOARD



LICENSE NUMBER	
CCC033709	

The ROOFING CONTRACTOR  
Named below IS CERTIFIED  
Under the provisions of Chapter 489 FS.  
Expiration date: AUG 31, 2018



MC KINNEY, GERALD W/II  
PRESTIGE METAL ROOFING INC  
6061 CINDERLANE PARKWAY  
SUITE 100  
ORLANDO FL 32810

ISSUED: 07/20/2016      DISPLAY AS REQUIRED BY LAW      SEQ # L1607200000936

**Scott Randolph, Tax Collector****Local Business Tax Receipt****Orange County, Florida**

This local business tax receipt is in addition to and not in lieu of any other tax required by law or municipal ordinance. Businesses are subject to regulation of zoning, health and other lawful authorities. This receipt is valid from October 1 through September 30 of receipt year. **Delinquent penalty is added October 1.**

1806 CERT ROOFING CONTRA \$30.00

**EXPIRES 9/30/2017**

1806-0508681  
1 EMPLOYEE ;

1 EMPLOYEE - 5000 BUSINESS OFFICE \$30.00



TOTAL TAX \$60.00  
PREVIOUSLY PAID \$60.00  
TOTAL DUE \$0.00

MCKINNEY GERALD W II

PRESTIGE METAL ROOFING INC  
GERALD W MCKINNEY II QUALIFIER  
6061 CINDERLANE PKWY #100  
ORLANDO FL 32810-4781

6061 CINDERLANE PKWY #100  
U - ORLANDO, 32810

PAID: \$60.00 2501-02229589 7/25/2016

This receipt is official when validated by the Tax Collector.

**Scott Randolph, Tax Collector****Local Business Tax Receipt****Orange County, Florida**

This local business tax receipt is in addition to and not in lieu of any other tax required by law or municipal ordinance. Businesses are subject to regulation of zoning, health and other lawful authorities. This receipt is valid from October 1 through September 30 of receipt year. **Delinquent penalty is added October 1.**

1801 CERT GENERAL CONTRA \$30.00

**EXPIRES 9/30/2017**

1801-0508679

1 EMPLOYEE



TOTAL TAX \$30.00  
PREVIOUSLY PAID \$30.00  
TOTAL DUE \$0.00

MCKINNEY GERALD W II

PRESTIGE METAL ROOFING INC  
FLORIDA INC  
MCKINNEY GERALD W II  
6061 CINDERLANE PKWY #100  
ORLANDO FL 32810-4781

6061 CINDERLANE PKWY #100  
U - ORLANDO, 32810

PAID: \$30.00 2501-02229610 7/25/2016

This receipt is official when validated by the Tax Collector.