



PERMIT CARD – PLEASE POST AT JOB SITE
 THIS DOCUMENT BECOMES YOUR PERMIT WHEN PROPERLY VALIDATED

Per FBC 105.3.3: An enforcing authority may not issue a building permit for any building construction, erection, alteration, modification, repair or addition unless the permit either includes on its face or there is attached to the permit the following statement: "NOTICE: In addition to the requirements of this permit, there may be additional restrictions applicable to this property that may be found in the public records of this county, and there may be additional permits required from other governmental entities such as water management districts, state agencies, or federal agencies." The issuance of this permit does not grant permission to violate any applicable City, Orange County, State of Florida and/or Federal codes and/or ordinances. Separate permits are required for Signs, Roofing, Electrical, Gas, Plumbing and Mechanical services. This permit becomes VOID if the work authorized is not commenced within 6 months, or is suspended or abandoned for a period of 6 months after commencement. WORK SHALL BE CONSIDERED SUSPENDED IF AN APPROVED INSPECTION HAS NOT BEEN MADE WITHIN A 6 MONTH PERIOD. PERMISSION IS GRANTED TO DO THE FOLLOWING WORK ACCORDING TO THE CONDITIONS HEREON AND THE APPROVED PLANS AND SPECIFICATIONS, SUBJECT TO COMPLIANCE WITH THE ORDINANCES OF THE CITY OF BELLE ISLE, FLORIDA.

Scope of Work: MECHANICAL: ONE 2.5 TON CHANGE OUT Comments: None Project Information Address: 2205 Nela Avenue, Belle Isle, FL 32809 Parcel ID: 19-23-30-5888-03-301 Property Owner: lwuc, Michael Phone Number: 407 509 3482 ***** Company Name: Ferran Service and Contracting Contractor Name: Monday, Vernon License Number: CAC010842 Address: 530 Grand Street, Orlando, FL 32805 Phone Number: 407 422 3551	Permit Number: 2015-08-058 Date of Application: 08/26/2015 Date Permit Issued: 08/28/2015 WARNING TO OWNER: "YOUR FAILURE TO RECORD A NOTICE OF COMMENCEMENT MAY RESULT IN YOU PAYING TWICE FOR IMPROVEMENTS TO YOUR PROPERTY. IF YOU INTEND TO OBTAIN FINANCING, CONSULT WITH YOUR LENDER OR AN ATTORNEY BEFORE RECORDING YOUR NOTICE OF COMMENCEMENT." ON THE JOB INSPECTION(S) MUST BE MADE BEFORE PROCEEDING WITH SUBSEQUENT WORK. THIS CARD MUST BE DISPLAYED OUTSIDE AND BE PROTECTED FROM THE WEATHER WHILE BEING VISIBLE FROM THE STREET UNTIL THE FINAL INSPECTIONS HAVE BEEN APPROVED.
---	---

BUILDING FEATURES

IMPACT FEES School \$ Traffic \$ ZONING FEES Zoning Fee \$ UNIVERSAL ENG - BUILDING FEES Cert of Occ \$ Demo \$ Building \$ Fence \$ Driveway \$ Shed \$ Window(s) \$ Door(s) \$ PrePower \$ Electrical \$ Temp Pole \$ Plumbing \$ Mechanical \$82.50 Gas \$ Roofing \$ Boat Dock \$ Screen Encl \$ Swimming Pool \$ Sign \$ SURCHARGE FEES Surcharge Fee \$2.00 Surcharge Fee \$2.00 TOTAL FEES \$86.50 Date Paid <u>8-28-15</u> CC or Check # <u>MC 4504</u> Amount Paid <u>86.50</u> The person accepting this permit shall conform to the terms of the application on file and construction shall conform to the requirements of the Florida Building Code (FS 553).	BUILDING INSPECTOR USE ONLY IF APPLICABLE: Have Zoning Approval Conditions Been Met? YES NO Have Stormwater Approval Conditions Been Met? YES NO Silt fencing in place? YES NO Turbidity Barrier in place? YES NO <input type="checkbox"/> BUILDING 1 st _____ (Footing/Foundation) Survey specific foundation plan must be onsite before slab pour. Approved Plan on Site? ____ 2 nd _____ (Slab) 3 rd _____ (Lintel)(Wall Reinforcing on Masonry Building) 4 th _____ (Exterior Framing)(Roof/Wall Sheathing) 5 th _____ (Framing) (To be made after Plumbing/ Mechanical/ Electrical Rough-Ins & Windows/Doors Installed) 6 th _____ (Insulation to be Made After Roof Installed) 7 th _____ (Drywall) 8 th _____ (Sidewalk/Driveway) 9 th _____ (Other) 10 th _____ (Final – After MEP and Other Applicable Finals) <input type="checkbox"/> ROOFING 1 ST ROOFING Deck Nailing/Dry-in/Flashing _____ 2 nd ROOFING Covering In-Progress _____ 3 rd ROOFING Covering Final _____ <input type="checkbox"/> PLUMBING (Pool-Piping, Solar, Irrigation, Water Treatment Equip, Etc...) 1 ST _____ (Underground) 2 nd _____ (Sewer) 3 rd _____ (Rough-In/Tub Set) 4 th _____ (Final) CHECK APPROPRIATE BOX <input type="checkbox"/> GAS <input type="checkbox"/> Natural <input type="checkbox"/> LP <input type="checkbox"/> MECHANICAL <input type="checkbox"/> ELECTRICAL <input type="checkbox"/> LOW VOLTAGE 1 st _____ (Rough-In) 2 nd _____ (Final)
--	---

Inspection requests are to be emailed to BD scheduling@UniversalEngineering.com; a confirmation email will be sent back to you upon scheduling. **Next-Day Inspection requests must be made by 1pm.** Please include the following in your request: Permit #, project address, type of inspection, date of the requested inspection, a contact name & a contact phone number. AM or PM may be requested but cannot be guaranteed.

For a copy of your permit, or to check inspection results, please visit <https://universalengineering.sharefile.com/f/fo94edc4-832d-44bd-9809-ecf32f9e2e63>
 login ID = cobi@universalengineering.com password = universal13

PROJECT NUMBER 0115.1501044-0000

TASK NUMBER 02

CITY OF BELLE ISLE
Permit Application Review Sheet

Permit Number	2015-08-058
Property Owner	IWUC Michael
Address	2205 Nela Ave
Nature of Improvement	Mechanical one 2.5 ton unit
Received Application	8-25-15
Sent for Stormwater Review	
Stormwater Approved	✓
Sent for Zoning Review	
Zoning Approved	✓
Applied for Variance	
Variance Approved	
Sent to BO for Review	8-26-15
Building Official Approved	
Comments	
1.	Susan 8-26-15 emailed Ferran we need tie downs ✓
2.	Susan 8-26-15 got tie downs WD # 56364 for review
3.	
4.	
5.	
6.	
7.	
8.	
9.	
10.	
11.	
12.	

Susan Manchester

From: John Connell
Sent: Thursday, August 27, 2015 8:36 AM
To: Susan Manchester
Cc: BIDReviews
Subject: RE: 2205 Nela Ave - on for tomorrow - review mechanical app 2015-08-058

Approved

From: Susan Manchester
Sent: Wednesday, August 26, 2015 4:24 PM
To: John Connell
Cc: BIDReviews
Subject: 2205 Nela Ave - on for tomorrow - review mechanical app 2015-08-058

Info on cover sheet. It will be on your schedule for tomorrow.

Thanks,

Susan



City of Belle Isle

Universal Engineering Sciences 3532 Maggie Blvd. Orlando, FL 32811
Tel 407-581-8161 * Fax 407-581-0313 * www.universalengineering.com

APPLICATION FOR MECHANICAL PERMIT

WARNING TO OWNER: YOUR FAILURE TO RECORD A NOTICE OF COMMENCEMENT MAY RESULT IN YOUR PAYING TWICE FOR IMPROVEMENTS TO YOUR PROPERTY. A NOTICE OF COMMENCEMENT MUST BE RECORDED AND POSTED ON THE JOB SITE BEFORE THE FIRST INSPECTION. IF YOU INTEND TO OBTAIN FINANCING, CONSULT WITH YOUR LENDER OR AN ATTORNEY BEFORE RECORDING YOUR NOTICE OF COMMENCEMENT.



DATE OF APPLICATION: _____ PERMIT NUMBER 2015-08-058
PLEASE PRINT. The undersigned hereby applies for a permit to make installations as indicated below:

Project Address 2205 NE 10 AVE, Belle Isle FL 32809 32812
Property Owner Michael Tward Phone 407-509-3442
Property Owner's Mailing Address 2205 NE 10 AVE City Belle Isle
State FL Zip Code 32809 Parcel Id Number: 19-23-30-588-03-301

To obtain this information, please visit <http://www.ocpafl.org/Searches/ParcelSearch.aspx>

Class of Building: Old New Type of Building: Residential Commercial Other
Type of Work: New Alteration Addition Repair

- REQUIRED: Tie Down Engineering
- REQUIRED: If adding A/C to new space, provide Energy Calculations & Equipment Sizing Calculations
- REQUIRED: If replacing unit with no duct work, Duct Certification as per FB 101.4.7.1, must be posted on unit

Please indicate the nature of work by completing the information below:

Air Conditioning: # of Units 1 Tons Per Unit 2 1/2 Total Tons 2 1/2 Estimated Cost \$ 4,774.00
Type of System: Water to Air Chiller Split System Package Heat Pump
Heating: # of Units KWS Per Unit 1 Total KWS 5 BTU's 27400 Estimated Cost \$ _____
Oil Electric Boiler Gas (A) Estimated Cost Fee \$ _____

Fees for items below are based on valuation of all units, equipment, materials and labor supplied by owner or contractor.

Ventilation: (Number of) Grease _____ Heat _____ Hoods, Air Intakes _____ Exhaust Fans _____ Dryer Vents _____ Estimated Cost \$ _____

Refrigeration: Number of units _____ Estimated Cost \$ _____

Piping: Air _____ Vacuum _____ Steam _____ Chill Water _____ Estimated Cost \$ _____

Others: (Specify) _____ Estimated Cost \$ _____

Was the space previously Air Conditioned? Yes No (B) Estimated Cost Fee \$ _____

I hereby certify that the above is true and correct to the best of my knowledge and make Application for Permit as outlined above, and if same is granted I agree to conform to all Florida Building Code Regulations and City Ordinances regulating same and in accordance with plans submitted. The issuance of this permit does not grant permission to violate any applicable Town and/or State of Florida codes and/or ordinances.

LICENSE HOLDER SIGNATURE Vernon Monday LICENSE # GAC-010842
LICENSE HOLDER NAME Vernon Monday COMPANY NAME Kerron Services
Street Address 530 Grand St
City Orlando State FL Zip Code 32805 Phone Number 407-422-3551
Email Address ngodwin@kerron-services.com

Building Official: Dee Date 8-26-15 Permit Fee \$ 55.00
Verified Contractor's Licenses & Insurance are on file [Signature] Date 8-26-15 Review Fee \$ 27.50
3% Florida Surcharge \$ 4.00
Total Permit Fee \$ 86.50

NOTE: The Building Permit Number is required if the Mechanical Installation is associated with any construction or alteration where a Building Permit has been issued. Building Permit Number _____

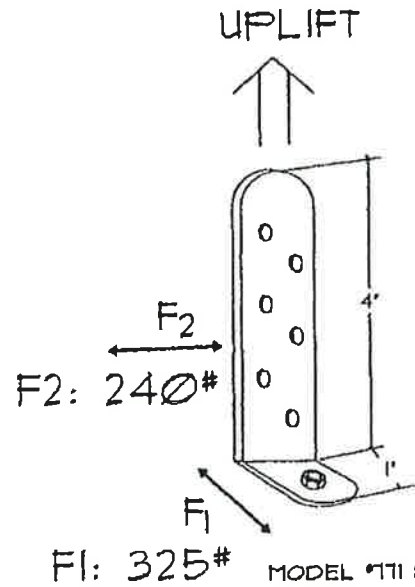

F1: 325# MODEL #711 SHOWN

USE MIN. OF 2- #14x3/4" SCREWS FOR 4" CLIP
 USE MIN. OF 2- #14x3/4" SCREWS FOR 6" CLIP
 USE 1/4" x 1 3/4" TAPCON TO CONCRETE PAD

METAL SHOP # 711 - 4" ANCHOR CLIP
 METAL SHOP # 712 - 6" ANCHOR CLIP

MAX UPLIFT: 505#

A/C ANCHOR CLIP

SHEET METAL SCREWS



#14x3/4"
 W/
 Neoprene
 washer

METAL FASTENERS

Tapcon



1/4" x 1 3/4"
 INTO
 CONCRETE
 PAD

RECOMENDED FASTENERS

1/4" x 1 3/4" TAPCON

MAXIMUM ALLOWABLE SHEAR LOAD FOR 1/4" DIA CONCRETE FASTENERS IN 2000 PSI MINIMUM STRENGTH CONCRETE IS: 325 LBS. PULL OUT (TENSION LOAD) STRENGTH OF TAPCON IS 505 LBS WITH 1 3/4" MIN. EMBEDMENT:

SINGLE SHEAR: 325 LBS
 TENSION: 505 LBS

LOAD CAPACITIES FOR TAPCONS

	Anchor Size	End. Depth	2,000 psi Concrete	4,000 psi Concrete	6,000 psi Concrete	Concrete Block	Red Brick
Tension Load (lbs.)	1/4"	1"	760	930	1,140	720	940
		1-1/4"	1,090	1,540	1,690	880	1,160
		1-1/2"	1,520	1,850	2,210	1,090	1,320
		1-3/4"	2,020	2,330	2,740	1,290	1,420
Shear Load (lbs.)	1/4"	1"	725	1,420	2,140	690	1,720
		1-1/4"	1,053	2,150	2,390	925	1,840
		1-1/2"	1,270	2,270	2,580	1,125	1,930
		1-3/4"	1,305	2,390	2,840	1,305	2,130

NOTE:
 The values listed above are ultimate load capacities for TAPCONS which should be reduced by minimum safety factor of 4 or greater to determine the allowable working load. Refer to the section on product selection guidelines for details. The consistency of hollow block and brick varies greatly. The load capacities listed above for hollow block and brick should be used as guides only. Job site tests should be conducted to determine the actual load capacities in these materials.

Notes:

1. Alternative fasteners may be used as shown in the details. All fasteners must meet or exceed the safe working load values specified by the manufacturer, and shall be approved by the building official.



REVISIONS

Joseph D. Hiller P.E.
 Florida P.E. License # 74583
 P.O. Box 28185
 Fort Orange, FL 32128
 Phone: 386-248-1700
 Email: hillerengineering@gmail.com

PROJECT: A/C Condensor Anchor Clip
THE METAL SHOP
 2541W. Dannelton Road
 Dannelton, FL 34433
 www.metalshop.org
 Phone: 888-471-2182 Fax: 352-522-0007

DATE: 8/29/2014
 DRAWN BY: AS NOTED
 CHECKED BY: J. HILLER

A-4
 4 4

#771 (4 pk.) / #772 (100 box) Anchor Clip

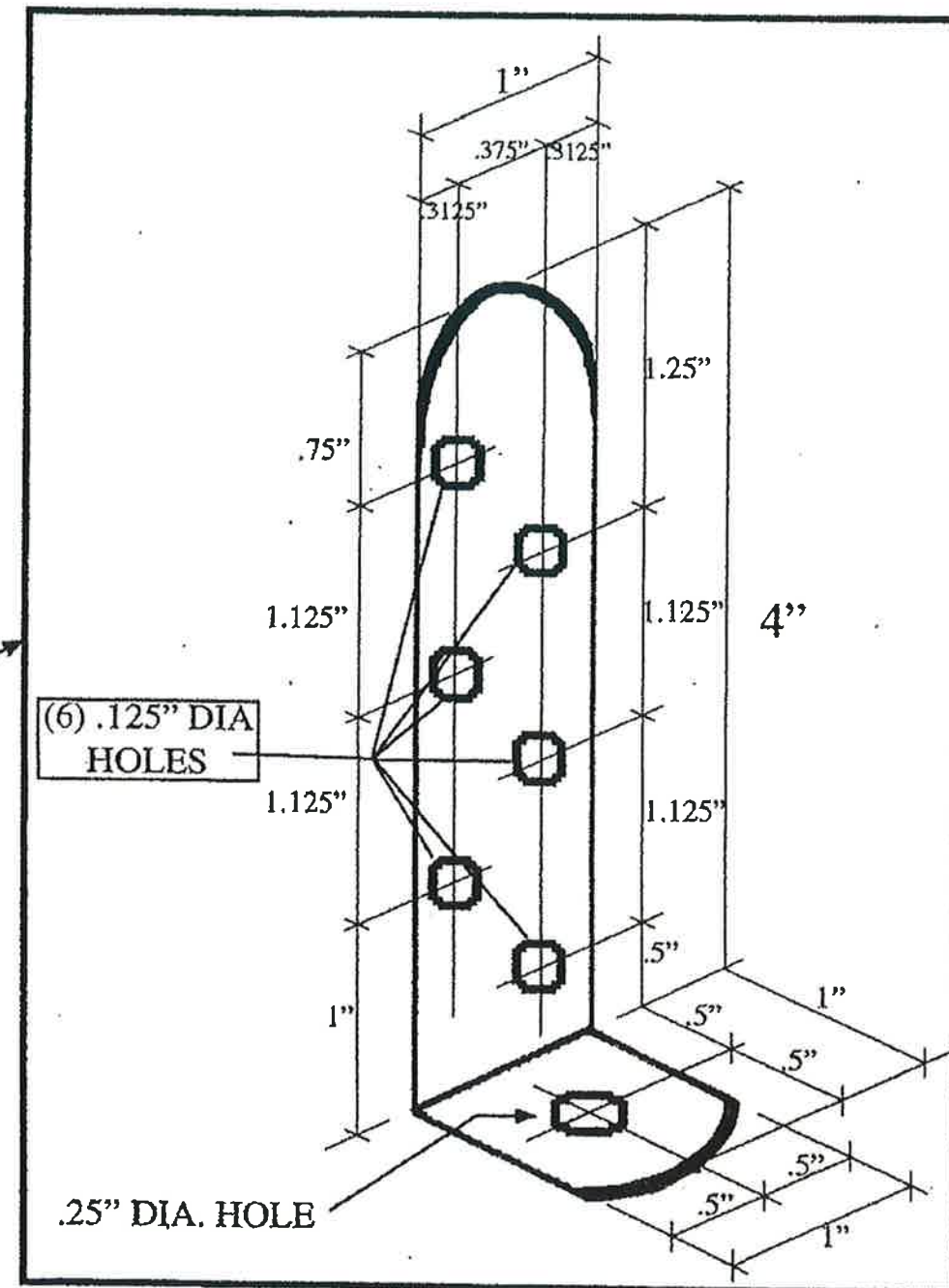
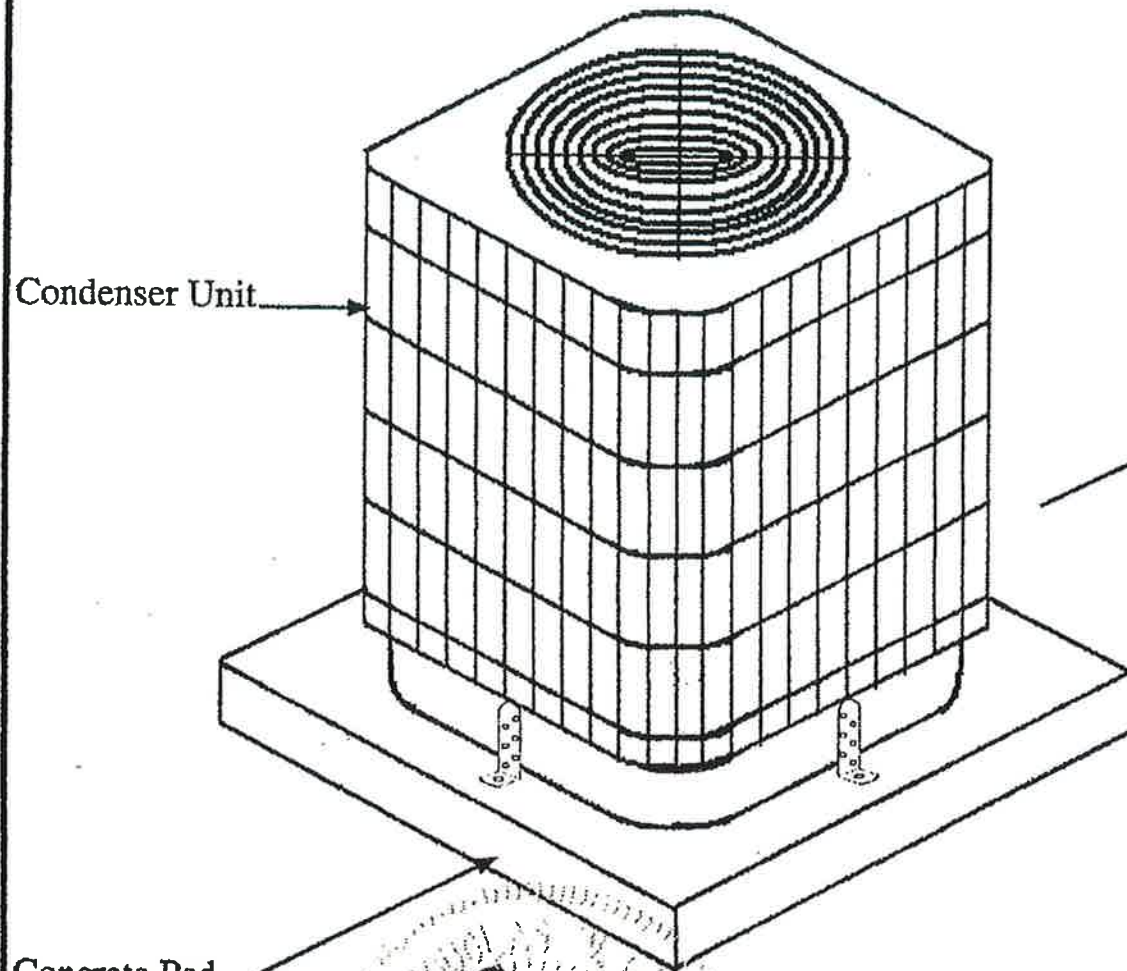

Metal thickness = 16 gauge

Reviewed for Code Compliance
Universal Engineering Sciences

[Signature]
249-08

<p>The Metal Shop 1139 Eldridge Street Clearwater Fl. 33755</p>	<p>Ph: (727) 441-2492 Fax: (727) 442-8493 Web: www.metalshop.org</p>	<p>Consulting Engineer: Douglas W. Lowe, P.E. FLA # 13355 1206 Millenium Parkway Brandon, Fl. 33511</p>	<p>Revision Date: 2/14/08</p>	<p>Drawn by: K.P.R. Scale - Not to scale</p>	<p>Page: 1 of 1</p>
---	--	--	--	---	--------------------------------