



City of Belle Isle

Universal Engineering Sciences 3532 Maggie Blvd., Orlando, FL 32811
 Tel 407-581-8161 * Fax 407-581-0313 * www.universalengineering.com

PERMIT CARD – PLEASE POST AT JOB SITE

THIS DOCUMENT BECOMES YOUR PERMIT WHEN PROPERLY VALIDATED

Per FBC 105.3.3: An enforcing authority may not issue a building permit for any building construction, erection, alteration, modification, repair or addition unless the permit either includes on its face or there is attached to the permit the following statement: "NOTICE: In addition to the requirements of this permit, there may be additional restrictions applicable to this property that may be found in the public records of this county, and there may be additional permits required from other governmental entities such as water management districts, state agencies, or federal agencies." The issuance of this permit does not grant permission to violate any applicable City, Orange County, State of Florida and/or Federal codes and/or ordinances. Separate permits are required for Signs, Roofing, Electrical, Gas, Plumbing and Mechanical services. This permit becomes VOID if the work authorized is not commenced within 6 months, or is suspended or abandoned for a period of 6 months after commencement. **WORK SHALL BE CONSIDERED SUSPENDED IF AN APPROVED INSPECTION HAS NOT BEEN MADE WITHIN A 6 MONTH PERIOD.** PERMISSION IS GRANTED TO DO THE FOLLOWING WORK ACCORDING TO THE CONDITIONS HEREON AND THE APPROVED PLANS AND SPECIFICATIONS, SUBJECT TO COMPLIANCE WITH THE ORDINANCES OF THE CITY OF BELLE ISLE, FLORIDA.

Scope of Work: WINDOWS: replace 11 size for size windows Comments: None Project Information Address: 3417 Warren Park Drive, Belle Isle, FL 32809 Parcel ID: 20-23-30-8860-00-160 Property Owner: McNutt, Peggy & Mary Phone Number: 407 473 3253 ***** Company Name: FASWD, LLC Contractor Name: Varga, Scott License Number: CGC1518212 Address: 3020 Mercy Drive, Orlando, FL 32808 Phone Number: 407-489-8683	Permit Number: 2015-04-041 Date of Application: 04/17/2015 Date Permit Issued: 04/21/2015 WARNING TO OWNER: "YOUR FAILURE TO RECORD A NOTICE OF COMMENCEMENT MAY RESULT IN YOU PAYING TWICE FOR IMPROVEMENTS TO YOUR PROPERTY. IF YOU INTEND TO OBTAIN FINANCING, CONSULT WITH YOUR LENDER OR AN ATTORNEY BEFORE RECORDING YOUR NOTICE OF COMMENCEMENT." ON THE JOB INSPECTION(S) MUST BE MADE BEFORE PROCEEDING WITH SUBSEQUENT WORK. THIS CARD MUST BE DISPLAYED OUTSIDE AND BE PROTECTED FROM THE WEATHER WHILE BEING VISIBLE FROM THE STREET UNTIL THE FINAL INSPECTIONS HAVE BEEN APPROVED.
--	---

BUILDING FEATURES

IMPACT FEES School \$ Traffic \$ ZONING FEES Zoning Fee \$ UNIVERSAL ENG - BUILDING FEES Cert of Occ \$ Demo \$ Building \$ Fence \$ Driveway \$ Shed \$ Window(s) \$73.50 Door(s) \$ PrePower \$ Electrical \$ Temp Pole \$ Plumbing \$ Mechanical \$ Gas \$ Roofing \$ Boat Dock \$ Screen Encl \$ Swimming Pool \$ Sign \$ SURCHARGE FEES Surcharge Fee \$2.00 Surcharge Fee \$2.00 TOTAL FEES \$77.50 Date Paid <u>4-21-15</u> CC or Check # <u>VISA 4147</u> Amount Paid <u>77.50</u> The person accepting this permit shall conform to the terms of the application on file and construction shall conform to the requirements of the Florida Building Code (FS 553).	BUILDING INSPECTOR USE ONLY IF APPLICABLE: Have Zoning Approval Conditions Been Met? YES NO Have Stormwater Approval Conditions Been Met? YES NO Silt fencing in place? YES NO Turbidity Barrier in place? YES NO <input type="checkbox"/> BUILDING 1 st _____ (Footing/Foundation) Survey specific foundation plan must be onsite before slab pour. Approved Plan on Site? _____ 2 nd _____ (Slab) 3 rd _____ (Lintel)(Wall Reinforcing on Masonry Building) 4 th _____ (Exterior Framing)(Roof/Wall Sheathing) 5 th _____ (Framing) (To be made after Plumbing/ Mechanical/ Electrical Rough-Ins & Windows/Doors Installed) 6 th _____ (Insulation to be Made After Roof Installed) 7 th _____ (Drywall) 8 th _____ (Sidewalk/Driveway) 9 th _____ (Other) 10 th _____ (Final – After MEP and Other Applicable Finals) <input type="checkbox"/> ROOFING 1 ST ROOFING Deck Nailing/Dry-in/Flashing _____ 2 nd ROOFING Covering In-Progress _____ 3 rd ROOFING Covering Final _____ <input type="checkbox"/> PLUMBING (Pool-Piping, Solar, Irrigation, Water Treatment Equip, Etc...) 1 ST _____ (Underground) 2 nd _____ (Sewer) 3 rd _____ (Rough-In/Tub Set) 4 th _____ (Final) CHECK APPROPRIATE BOX <input type="checkbox"/> GAS <input type="checkbox"/> Natural <input type="checkbox"/> LP <input type="checkbox"/> MECHANICAL <input type="checkbox"/> ELECTRICAL <input type="checkbox"/> LOW VOLTAGE 1 st _____ (Rough-In) 2 nd _____ (Final)
--	---

Inspection requests are to be emailed to BDscheduling@UniversalEngineering.com; a confirmation email will be sent back to you upon scheduling. **Next-Day Inspection requests must be made by 1pm.** Please include the following in your request: Permit #, project address, type of inspection, date of the requested inspection, a contact name & a contact phone number. AM or PM may be requested but cannot be guaranteed.



CITY OF BELLE ISLE

Universal Engineering Sciences 3532 Maggie Blvd., Orlando, FL 32811
Tel 407-581-8161 * Fax 407-581-0313 * www.universalengineering.com

Building Permit (Land Use) Application

DATE: 2-20-15

PERMIT # 2015-04-04C

PROJECT ADDRESS 3417 WARREN PARK ROAD, Belle Isle, FL 32809 32812
PROPERTY OWNER PEGGY AND MARY MCNUTT PHONE 407-473-3256 VALUE OF WORK (labor & material) \$ 6725.00

PLEASE LIST THE NATURE OF YOUR PROPOSED IMPROVEMENTS

REPLACE 11 SIZE FOR SIZE WINDOWS

Please provide information, if applicable.

- Survey specific foundation plan required to show compliance with zoning setbacks
- **BOAT DOCK:** DEP Clearance Required with Application (Call 407-897-4100); please provide a copy of their report
- **SEPTIC SYSTEM (RESIDENTIAL):** - Provide verification of OC Health Dept approval for on-site septic tank system, per FAC Chap. 64E-6
- Homeowners will be required to have a contractor on record for homes that are rented and/or not homestead

20-23-30-8860-00-160

Please Complete for the City of Belle Isle Zoning Review: Parcel Id Number: 20-23-30-8860-00-160
To obtain this information, please visit <http://www.ocpaf1.org/Searches/ParcelSearch.aspx>

SPECIAL CONDITIONS: STRUCTURES MAY NOT ENCROACH INTO ANY EASEMENT OR REQUIRED SETBACK. Note, this Zoning Approval MAY or MAY NOT be in conflict with your Deed Restrictions. For New Single Family Residence, a Traffic Impact Fee and School Impact will be assessed.

Wind Exposure Category: B C D

Attached Survey SETS and Construction Plans SETS

PLANNING & ZONING APPROVAL: _____
DATE _____

PLEASE COMPLETE for Building Review

CONSTRUCTION TYPE _____
 OCCUPANCY GROUP Comm Res: Single Fam Multi Fam
 #BLDG. _____ #UNITS _____ #STORIES _____ TOTAL SQ.FT. _____
 MAX. FLOOR LOAD _____ MAX. OCCUPANCY _____
 MIN. FLOOD ELEV. _____ LOW FLOOR ELEV. _____
 WATER SERVICE _____ WELL _____ SEPTIC _____

SPRINKLERS REQ'D Y N

If Required - SUBMIT COPY OF PLANS FOR FIRE

REVIEW Date: Sent _____ RCD _____

REVIEW	Y	N	\$
ZONING	Y	N	\$ _____
CERT OF OCC	Y	N	\$ _____
TRAFFIC	Y	N	\$ _____
SCHOOL	Y	N	\$ _____
FIRE	Y	N	\$ _____
SWIMMING POOL	Y	N	\$ _____
SCREEN ENCLOSURE	Y	N	\$ _____
ROOFING	Y	N	\$ _____
BOAT DOCK	Y	N	\$ _____
BUILDING	Y	N	\$ _____
WINDOW(S)	<input checked="" type="radio"/>	N	\$ <u>1350</u>
DOOR(S)	Y	N	\$ _____
FENCE	Y	N	\$ _____
SHED	Y	N	\$ _____
DRIVEWAY	Y	N	\$ _____
OTHER	Y	N	\$ _____

BUILDING REVIEWER DATE 4-20-15

VERIFIED CONTRACTOR'S LICENSE & INSURANCE ARE ON FILE DATE 4-17-15

3% FL SURCHARGE 400
TOTAL 1750

Per FSS 105.3.3:
An enforcing authority may not issue a building permit for any building construction, erection, alteration, modification, repair or addition unless the permit either includes on its face or there is attached to the permit the following statement: "NOTICE: In addition to the requirements of this permit, there may be additional restrictions applicable to this property that may be found in the public records of this county, and there may be additional permits required from other governmental entities such as water management districts, state agencies, or federal agencies."

Republic Services is by legal contract the sole authorized provider of garbage, recycling, yard waste, and commercial garbage and construction debris collection and disposal services with the city limits of the City. Contractors, homeowners and commercial businesses may contact Republic Services at 407-293-8000 to setup accounts for Commercial, Construction Roll Off, or other services needed. Rates are fixed by contract and are available at City Hall or from Republic Services. The City enforces the contract through its code enforcement office. Failure to comply will result in a stop work order.

By Owner Form Y NA
 Notice of Commencement Y NA
 Power of Attorney Y NA
 Contractor Packet Included? Y N

SEPARATE PERMITS ARE REQUIRED FOR ROOFING, ELECTRICAL, PLUMBING, GAS, MECHANICAL, SIGNS, POOLS, ENCLOSURES, ETC.

OTHER PERMITS REQUIRED:

ELECTRICAL	Y	NA
PREPOWER	Y	NA
MECHANICAL	Y	NA
PLUMBING	Y	NA
ROOFING	Y	NA
GAS	Y	NA



City of Belle Isle
 Universal Engineering Sciences 3532 Maggie Blvd., Orlando, FL 32811
 Tel 407-581-8161 * Fax 407-581-0313 * www.universalengineering.com

Building Permit (Land Use) Application
 To be completed as required by State Statute Section 713 and other applicable sections.

PERMIT # 2015-04-041

Owner's Name Mary McNutt
 Owner's Address 3417 Warren Park Rd Belle Isle FL 32812

Contractor Name <u>Scott A. Varga</u>	Company Name <u>FASWD, LLC</u>
License # <u>CGC1518212</u>	Company Address <u>3020 Mercy Drive</u>
Contact Phone/Cell <u>407-489-8683</u>	City, State, ZIP <u>Orlando, FL 32808</u>
Contact Email <u>jeana.mail@gmail.com</u>	Contact Fax

WARNING TO OWNER: Your failure to record a Notice of Commencement may result in your paying twice for improvements to your property. A notice of commencement must be recorded if job is \$2500(+) or if A/C Replacement \$7500(+) and posted on the job site before the first inspection. If you intend to obtain financing, consult with your lender or an attorney before recording your Notice of Commencement.

I hereby make Application for Permit as outlined above, and if same is granted I agree to conform to all Division of Building Safety Regulations (www.floridabuilding.org) and City Ordinances (www.municode.com) regulating same and in accordance with plans submitted. The issuance of this permit does not grant permission to violate any applicable City and/or State of Florida codes and/or ordinances. Application is hereby made to obtain a permit to do the work and installations as indicated. I certify that no work or installation has commenced prior to the issuance of a permit and that all work will be performed to meet the standards of all laws regulating construction in this jurisdiction. I understand that a separate permit must be secured for all other construction including ROOFING, ELECTRICAL, MECHANICAL, PLUMBING, GAS, SIGNS, POOLS, SCREEN ENCLOSURES, ETC.

OWNER'S AFFIDAVIT: I certify that all the foregoing information is accurate and that all work will be done in compliance with all applicable laws regulating construction and zoning.

Owner Signature Mary McNutt
 The foregoing instrument was acknowledged before me this 4/6/15
 by Mary R. McNutt who is personally known to me
 and who produced D.I.
 as identification and who did not take an oath.
 Notary as to Owner _____
 State of Florida _____
 County of Orange _____

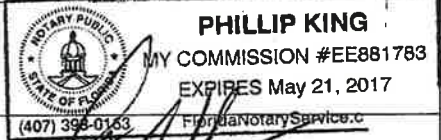

Contractor Signature Scott A. Varga
 COMPANY NAME FASWD, LLC
 The foregoing instrument was acknowledged before me this 4/15/15
 by Scott A. Varga who is personally known to me
 and who produced _____
 as identification and who did not take an oath.
 Notary as to Owner _____
 State of Florida _____
 County of Orange _____

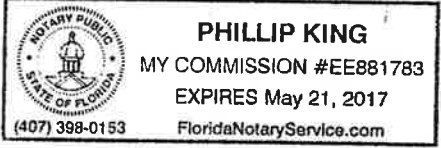

Impervious Surface Ratio Worksheet
 Development Zoned A-1, A-2, R-1-AAA, R-1-AA, R-1-A, R-1 per City Code, Section 50-74: Impervious Surface Ratio

- Total Lot Area (sqft) X 0.35 = Allowable Impervious Area (BASE).
 Total Lot Area _____ X 0.35 =
 Allowable Impervious Area (BASE) _____
- Calculate the "proposed" impervious area on the lot. This includes the sum of all areas that do not allow direct percolation of rainwater. Examples include house, pool, deck, driveway, accessory building, etc.
 - House _____
 - Driveway _____
 - Walkway _____
 - Accessory Buildings _____
 - Pool & Spa _____
 - Deck & Patio _____
 - Other _____
 Actual Impervious Area (AIA) _____
- If AIA is less than BASE, subtract AIA from BASE to determine the amount of impervious area that may be added without providing onsite retention.
- If AIA is greater than BASE, then onsite retention **must be provided**.
 Assuming 7.5 inches of rainfall based on a 24hr 10 year Rain Event (TP40), the formula is: (7.5 inches rainfall/12 inches p/foot) X (result from line 4) = cubic feet of storage volume needed

Prepared By: J. Young
Return to: FASWD, LLC
3020 Mercy Dr. Orlando, FL 32808

NOTICE OF COMMENCEMENT



State of Florida
County of Orange
Parcel ID: 20-23-30-8860-00-160 Permit #: 2015-04-041

The undersigned hereby gives notice that improvement will be made to certain real property. In accordance with Chapter 713, Florida Statutes, the following information is provided in the Notice of Commencement:

1. Legal description of Property (and street address if available): 3417 Warren Park Rd Venetian Villas S/69 Lot 16
2. General description of improvement: window replacement
- 3 a. Owner name/address: Mary McNeill
- b. Interest in property: 3411 Warren Park Rd Belle Isle FL 32812
- c. Name and address of fee simple title holder (if other than owner): _____
4. Contractor Name and Address: FASWD, LLC
3020 MERCY DRIVE, ORLANDO, FL 32808
Phone: 407-770-0184 Fax: 407-770-0187
5. Surety - Name and Address: Na
Amount of bond: \$ _____
6. Lender - Name and Address: Na
7. Persons within the State of Florida designated by Owner upon whom notices or other documents may be served as provided by Section 713.13(1)(a) 7, Florida Statutes: _____
8. In addition to him/herself, Owner designates the following person(s) to receive a copy of the Lienor's Notice as provided in Section 713.13(1)(b), Florida Statutes [Provide Name/Mailing Address]: _____
9. NOC expiration date (one full year from the date of recording unless different date is specified): _____

44893

WARNING TO OWNER: ANY PAYMENTS MADE BY THE OWNER AFTER THE EXPIRATION OF THE NOTICE OF COMMENCEMENT ARE CONSIDERED IMPROPER PAYMENTS UNDER CHAPTER 713, PART I, SECTION 713.13, FLORIDA STATUTES, AND CAN RESULT IN YOUR PAYING TWICE FOR IMPROVEMENTS TO YOUR PROPERTY. A NOTICE OF COMMENCEMENT MUST BE RECORDED AND POSTED ON THE JOB SITE BEFORE THE FIRST INSPECTION. IF YOU INTEND TO OBTAIN FINANCING, CONSULT WITH YOUR LENDER OR AN ATTORNEY BEFORE COMMENCING WORK OR RECORDING YOUR NOTICE OF COMMENCEMENT.

Verification pursuant to Section 92.525, Florida Statutes: Under penalties of perjury, I declare that I have read the foregoing and that the facts stated in it are true to the best of my knowledge and belief.

Mary R McNeill, executor
Signature of Owner/A Natural Person (or Owner's Authorized Officer/Director/Partner/Manager)

The foregoing instrument was acknowledged before me this _____ day of _____, 20____, by _____ (print name of person) as _____ (type of authority) for _____ (name of party on behalf of whom instrument was executed).

Notary Public _____

Personally Known _____ -OR- Produced Identification

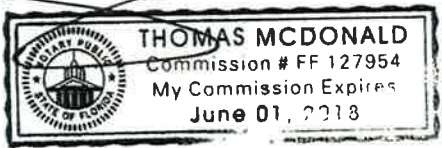

VA DR LIC # A 61639095
I hereby certify that this is a true copy of the document as recorded in the Official Records.
MARTHA O HAYNIE, COUNTY COMPTROLLER
By: C. Sampson
Deputy Comptroller
Date: 4-17-15





City of Belle Isle

Universal Engineering Sciences 3532 Maggie Blvd., Orlando, FL 32811
 Tel 407-581-8161 * Fax 407-581-0313 * www.universalengineering.com

Product Approval Form

DATE: 4-16-2015

PERMIT # _____

PROJECT ADDRESS 3417 Warren Park Rd

Belle Isle, FL 32809 32812

As required by Florida Statute 553.842 and Florida Administrative Code 9B-72m, please provide the information and approval numbers of the building components listed below if they will be utilized on the building or structure. FL Approved products are listed online at www.floridabuilding.org or can be obtained from the local product supplier. The following information must be turned in with permit application and available onsite for inspections:

1. This Product Approval Cover Sheet
2. Internet screen from FloridaBuilding.org showing PA#, approval and code edition stamped
3. Manufacturer's installation details from FloridaBuilding.org and requirements for each product stamped

Product Type	Manufacturer	Model/Series	FL Product Approval #	Product Type	Manufacturer	Model/Series	FL Product Approval #
EXTERIOR DOORS				WALL PANELS			
Swinging				Sliding			
Sliding				Soffits			
Sectional/Rollup				Storefront			
Other				Glass Block			
				Other			
WINDOWS				ROOFING PRODUCTS			
Single/Dbf Hung	Simonton	5050	5167.13	Asphalt Shingles			
Horizontal Slider				Non Struct Metal			
Casement				Roofing Tiles			
Fixed				Single Ply Roof			
Mullion	Simonton	Mull	4787.1	Other			
Skylights							
Other							
STRUCTURAL COMPONENTS				OTHER			
Wood Connectors							
Wood Anchors							
Truss Plates							
Insulation Forms							
Lintels							
Other							

It is the applicant's responsibility to verify that specific products have been installed in accordance with their limitations and with the minimum required design pressures for the structure. Specific compliance will be verified during field inspections.

Applicant Signature

Date 4-16-15



FL #	FL5167-R16										
Application Type	Revision ✓ 5167.13										
Code Version	2010										
Application Status	Approved *Approved by DBPR. Approvals by DBPR shall be reviewed and ratified by the POC and/or the Commission if necessary.										
Comments											
Archived	<input type="checkbox"/>										
Product Manufacturer	Simonton Windows										
Address/Phone/Email	1 Cochrane Ave Pennsboro, WV 26415 (800) 746-6687 Ext 2329 tiffany.davies@simonton.com										
Authorized Signature	Tiffany Davies tiffany.davies@simonton.com										
Technical Representative	Tiffany Davies										
Address/Phone/Email	PO Box 1646 5300 Briscoe Road Parkersburg, WV 26102 (800) 542-9118 Ext 9329 tiffany_davies@simonton.com										
Quality Assurance Representative	AAMA										
Address/Phone/Email	1827 Walden Office Square Suite 550 Schaumburg, IL 60173 (847) 303-5664 webmaster@aamanet.org										
Category	Windows										
Subcategory	Double Hung 5050										
Compliance Method	Certification Mark or Listing										
Certification Agency	American Architectural Manufacturers Association										
Validated By	American Architectural Manufacturers Association										
Referenced Standard and Year (of Standard)	<table border="0"> <thead> <tr> <th>Standard</th> <th>Year</th> </tr> </thead> <tbody> <tr> <td>AAMA 450</td> <td>2006</td> </tr> <tr> <td>AAMA 450</td> <td>2010</td> </tr> <tr> <td>AAMA/WDMA/CSA 101/I.S.2 A440</td> <td>2005</td> </tr> <tr> <td>AAMA/WDMA/CSA 101/I.S.2 A440</td> <td>2008</td> </tr> </tbody> </table>	Standard	Year	AAMA 450	2006	AAMA 450	2010	AAMA/WDMA/CSA 101/I.S.2 A440	2005	AAMA/WDMA/CSA 101/I.S.2 A440	2008
Standard	Year										
AAMA 450	2006										
AAMA 450	2010										
AAMA/WDMA/CSA 101/I.S.2 A440	2005										
AAMA/WDMA/CSA 101/I.S.2 A440	2008										
Equivalence of Product Standards Certified By											

5167.13	43-40 and 43-45	Reflections 5050, Reflections 5300, Prism Bronze, Prism Ultra Gold Amcraft Grand Estates, Amcraft Grand Estates Plus, THD 6100 Vantage Pointe Vinyl Double Hung
Limits of Use Approved for use in HVHZ: No Approved for use outside HVHZ: Yes Impact Resistant: No Design Pressure: N/A Other: 36x72 (+/-30 PSF), 52x71 (+/-35 PSF), 48x80 (+/-35 PSF), 36x63 (+/-45 PSF), 44x63 (+/-45 PSF), 32x62 (+/-50 PSF), 36x74 (+/-50 PSF)		Certification Agency Certificate FL5167 R14 C CAC 43-40 DH 32x62 R50.pdf FL5167 R14 C CAC 43-40 DH 36x63 R45.pdf FL5167 R14 C CAC 43-40 DH 36x72 R30.pdf FL5167 R14 C CAC 43-40 DH 36x74 R50.pdf FL5167 R14 C CAC 43-40 DH 44x63 R45.pdf FL5167 R14 C CAC 43-40 DH 48x80 R35.pdf FL5167 R14 C CAC 43-40 DH 52x71 R35.pdf FL5167 R14 C CAC 43-45 waiver to 43-40.pdf Quality Assurance Contract Expiration Date 06/10/2014 Installation Instructions FL5167 R14 II IN0432b 43-40 43-45 DH 2X.pdf Verified By: American Architectural Manufacturers Association Created by Independent Third Party: Evaluation Reports Created by Independent Third Party:
5167.14	43-50 (Three-Step Sill)	6100 Vantage Pointe, Asure, Prism Gold, Grand Estates Vinyl Double Hung
Limits of Use Approved for use in HVHZ: No Approved for use outside HVHZ: Yes Impact Resistant: No Design Pressure: N/A Other: 52x71 (+/-35 PSF), 36x63 (+/-45 PSF), 44x63 (+/-45 PSF), 32x62 (+/-50 PSF), 36x74 (+/-50 PSF)		Certification Agency Certificate FL5167 R14 C CAC 43-50 DH 32x62 R50.pdf FL5167 R14 C CAC 43-50 DH 36x63 R45.pdf FL5167 R14 C CAC 43-50 DH 36x74 R50.pdf FL5167 R14 C CAC 43-50 DH 44x63 R45.pdf FL5167 R14 C CAC 43-50 DH 52x71 R35.pdf Quality Assurance Contract Expiration Date 01/25/2016 Installation Instructions FL5167 R14 II IN0432 43-50 DH 2X.pdf Verified By: American Architectural Manufacturers Association Created by Independent Third Party: Evaluation Reports Created by Independent Third Party:
5167.15	75-75, 75-09, 07-75, 07-09, 07-10 and 07-20	Reflections 5500, Prism Platinum, Sears 9300, Generations, Impressions 9800, THD 6500 Vantage Pointe, Amcraft Grand Estates Premier/Premium Plus, Grandura Vinyl Double Hung
Limits of Use Approved for use in HVHZ: No Approved for use outside HVHZ: Yes Impact Resistant: No Design Pressure: N/A Other: 48x80 (+/-25 PSF), 53x74 (+/-30 PSF), 48x80 (+/-35 PSF), 52x71 (+/-35 PSF), 53x80 (+/-40 PSF), 36x63 (+/-50 PSF), 36x74 (+/-50 PSF)		Certification Agency Certificate FL5167 R14 C CAC 07-10 07-20 to 07-09 Waiver.pdf FL5167 R14 C CAC 07-75 75-09 07-09 to 75-75 Waiver.pdf FL5167 R14 C CAC 07-75 DH 48x80 R35.pdf FL5167 R14 C CAC 07-75 DH 53x74 R30.pdf FL5167 R14 C CAC 07-75 DH 53x80 R40.pdf FL5167 R14 C CAC 75-75 DH 36x63 R PG50.pdf FL5167 R14 C CAC 75-75 DH 36x74 LC50.pdf FL5167 R14 C CAC 75-75 DH 48x80 LC PG25.pdf FL5167 R14 C CAC 75-75 DH 52x71 R PG35.pdf Quality Assurance Contract Expiration Date 01/11/2014 Installation Instructions FL5167 R14 II IN0113 75-75 75-09 07-75 07-09 07-10 07-20 DH 2X.pdf Verified By: American Architectural Manufacturers Association Created by Independent Third Party: Evaluation Reports Created by Independent Third Party:
5167.16	75-75, 75-09, 07-75, 07-09, 07-10 and 07-20	Reflections 5500, Prism Platinum, Sears 9300, Generations, Impressions 9800, 6500 Vantage Pointe, Amcraft Grand Estates Premier/Premium Plus, Grandura Vinyl Double Hung H-Mulled Triple
Limits of Use Approved for use in HVHZ: No Approved for use outside HVHZ: Yes Impact Resistant: No Design Pressure: +50/-50 Other: 109x74 (+/-50 PSF)		Certification Agency Certificate FL5167 R14 C CAC 07-10 07-20 waiver to 07-09.pdf FL5167 R14 C CAC 07-75 75-09 07-09 to 75-75 Waiver.pdf FL5167 R14 C CAC 75-75 DH Triple 109x74 R PG50.pdf Quality Assurance Contract Expiration Date 09/13/2016

MODEL DESIGNATION: **Simonton Double Hung Series 43-40 / 43-45 Vinyl Window**
 MAXIMUM OVERALL NOMINAL SIZE: See Size Chart
 DESIGN PRESSURE RATING: See Size Chart
 USABLE CONFIGURATIONS: X

GENERAL DESCRIPTION: The head, sill, and side jambs are extruded PVC. The wall thickness through which the anchor screw penetrates is a minimum of 0.120".

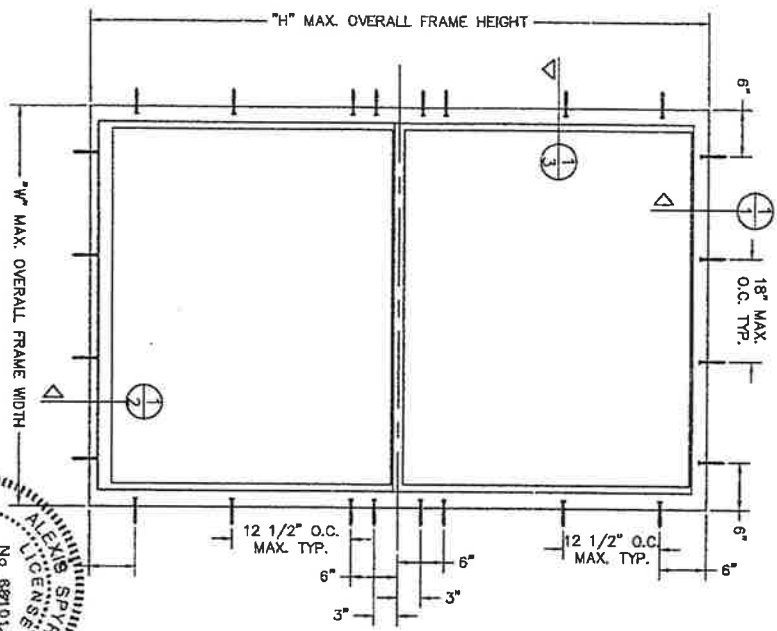

SIZE CHART		DP RATING
OVERALL SIZE		
WIDTH "W"	HEIGHT "H"	
46"	84"	±25 PSF
36"	72"	±30 PSF
48"	80"	±35 PSF
44"	63"	
52"	71"	±45 PSF
36"	63"	
44"	63"	±50 PSF
36"	74"	
32"	62"	

NOTES:
 1. This installation has been evaluated for use in locations adhering to the Florida Building Code and where design pressure requirements as determined by ASCE 7 Minimum Design Loads for Buildings and Other Structures do not exceed the design pressure ratings listed herein.
 2. For installation where the sub-buck is less than 1 1/2" (FBC chapter 17 Anchorage Methods) Topcon type concrete anchors must be used and the length must be such that a minimum 1 1/4" embedment of the Topcon into the concrete or concrete block is obtained, unless otherwise noted. Anchors should be a minimum of 2 1/2" from the edge of the concrete, hollow block CMU, or concrete block.
 3. All interior and exterior perimeter surfaces of the window must be caulked.
 4. Adjust Topcon anchor locations, if necessary, to maintain a minimum of 2.0" clearance from mortar joints.
 5. When the optional head expanders are used, the INSTALLER MUST ADJUST the anchor lengths to maintain the required minimum embedment into the substrate.
 6. Anchors shall be specified and spaced as shown. Anchor embedment to base material shall be beyond wall dressing or silico and into wood or concrete, that full support of the frame is provided.
 7. Wood bucks (by others) must be engineered and anchored properly to transfer loads to the structure. Bucks shall extend beyond interior face of frame such that full support of the frame is provided.
 8. Follow ITW/Elco Topcon anchoring instructions.
 9. The responsibility for selection of Simonton Products to meet any applicable local laws, building codes, ordinances, or other safety requirements rests solely with the architect, building owner, or contractor.
 10. For woodbuck substrates, use #10 wood screws with 1 1/2" min. embedment into wood, unless otherwise noted. Screws should be a minimum of 3/4" from the edge of the wood.
 11. A. Concrete compressive strength = 3000 PSI at 28 days.
 B. Concrete Masonry Units shall conform with strength requirements of ASTM C90.
 C. Wood Minimum Specific Gravity = 0.55
 12. Shims are optional. Max. shim stack is 1/4".
 13. When using a 3/16" Topcon or #10 wood screw through the window frame, pre-drill the thru hole at specified installation screw locations.
 14. When used in areas requiring impact protection, this product REQUIRES the use of approved impact resistant shutters or other external protection.
 15. Flashing should be applied using the ASTM E 2112 method appropriate for the opening into which the window is being installed.
 16. Glazing shall comply with ASTM E 1300-04.

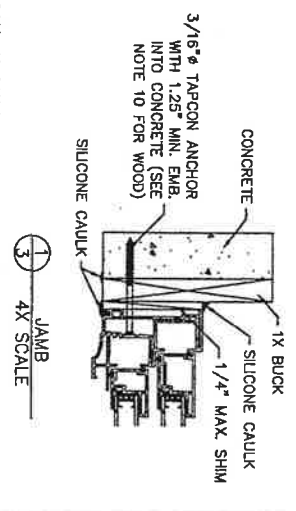
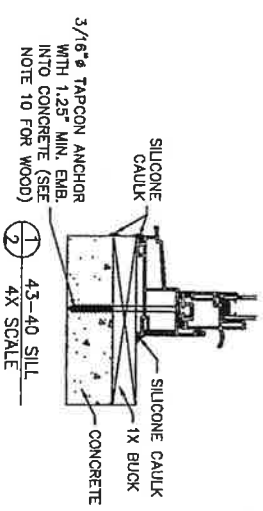
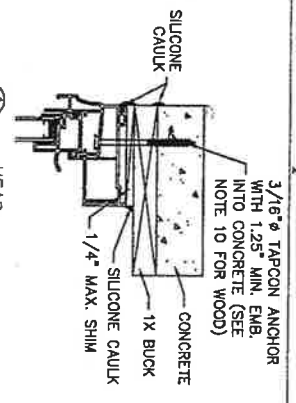

REV.	REVISIONS	REVISOR	DATE
1	UPDATED NOTES, GENERAL DESCRIPTION, AND SIZE CHART FOR THE TEST AND REMOVED	T.D.B.	12/23/08
2	43-45 SASH-FRAME CORE	T.D.B.	02/01/10
3	UPDATED SIZES PER NEW TESTING AND ADDED NOTES 15 & 16	T.D.B.	11/30/11

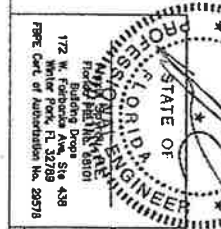

ALEX SPYROU
 2012.02.12 20:34:42 -05'00'

DISCLAIMER STATEMENT	
This document is the property of Simonton Windows, which retains all proprietary and other rights to its subject matter. It is provided to the recipient on the condition that it is not to be used, copied, or otherwise reproduced, in whole or in part, nor used in conjunction with the design, manufacture or repair of goods for anyone other than Simonton Windows without its consent. This restriction does not limit the recipient's rights to utilize information contained in this document, which is properly obtained from another source.	

DIMENSIONAL TOLERANCES	
Lengths	± 0.03
Widths	± 0.01
Angles	± 30 min.
Surfaces	± 0.005

SIMON TON	
1 Cochran Avenue Fonderson, WV 26415	B. INCHES DRAWN BY: DATE CHECKED BY: DATE APPROVED BY: DATE
SCALE: 1/4" = 1'-0"	SHEET: 1 of 1
SERIES: 43-40 DOUBLE HUNG	
TITLE: 1X BUCK INSTALLATION	



Product Approval
USER: Public User

Product Approval Menu > Product or Application Search > Application List > **Application Detail**



FL # **FL14787-R1**
 Application Type Revision
 Code Version 2010 ✓ **14787.1**
 Application Status Approved

Comments
Archived

Product Manufacturer **Simonton Windows**
 Address/Phone/Email **1 Cochrane Ave
 Pennsboro, WV 26415
 (800) 746-6687 Ext 2329
 tiffany.davies@simonton.com**

Authorized Signature **Tiffany Davies
 tiffany.davies@simonton.com**

Technical Representative **Tiffany Davies**
 Address/Phone/Email **PO Box 1646
 5300 Briscoe Road
 Parkersburg, WV 26102
 (800) 542-9118 Ext 9329
 tiffany_davies@simonton.com**

Quality Assurance Representative **AAMA**
 Address/Phone/Email **1827 Walden Office Square
 Suite 550
 Schaumburg, IL 60173
 (847) 303-5664
 webmaster@aamanet.org**

Category **Windows**
 Subcategory **Mullions**

Compliance Method **Evaluation Report from a Florida Registered Architect or a Licensed Florida Professional Engineer
 Evaluation Report - Hardcopy Received**

Florida Engineer or Architect Name who developed the Evaluation Report **Lucas Andrew Turner**
 Florida License **PE-58201**
 Quality Assurance Entity **Architectural Testing, Inc.**
 Quality Assurance Contract Expiration Date **12/31/2015**
 Validated By **Scott Wolters, PE**
 Validation Checklist - Hardcopy Received

Certificate of Independence **FL14787_R1_COI_EvalReport-RM0015r5.pdf**

Referenced Standard and Year (of Standard)

Equivalence of Product Standards
Certified By

Sections from the Code

1715.5.5

Product Approval Method

Method 2 Option B

Date Submitted

06/21/2012

Date Validated

06/22/2012

Date Pending FBC Approval

07/01/2012

Date Approved

08/07/2012

Summary of Products

FL #	Model, Number or Name	Description
14787.1	Reinforced Stand Alone Mullions Non-Impact	Extruded Vinyl Mullions with Aluminum Reinforcement
Limits of Use Approved for use in HVHZ: No Approved for use outside HVHZ: Yes Impact Resistant: No Design Pressure: N/A Other: Design pressure ratings vary by unit and mullion size. See installation drawings for applicable design pressure rating.		Installation Instructions FL14787_R1_II_RM0015r5_Non_Impact.pdf Verified By: Lucas Andrew Turner, P.E. 58201 Created by Independent Third Party: Yes Evaluation Reports FL14787_R1_AE_EvalReport-RM0015r5.pdf Created by Independent Third Party: Yes

[Back](#) [Next](#)

Contact Us :: 1940 North Monroe Street, Tallahassee FL 32399 Phone: 850-487-1824

The State of Florida is an AA/EEO employer. Copyright 2007-2013 State of Florida. :: [Privacy Statement](#) :: [Accessibility Statement](#) :: [Refund Statement](#)

Under Florida law, email addresses are public records. If you do not want your e-mail address released in response to a public-records request, do not send electronic mail to this entity. Instead, contact the office by phone or by traditional mail. If you have any questions, please contact 850.487.1395. *Pursuant to Section 455.275(1), Florida Statutes, effective October 1, 2012, licensees licensed under Chapter 455, F.S. must provide the Department with an email address if they have one. The emails provided may be used for official communication with the licensee. However email addresses are public record. If you do not wish to supply a personal address, please provide the Department with an email address which can be made available to the public. To determine if you are a licensee under Chapter 455, F.S., please click [here](#).

Product Approval Accepts:



SIMONTON
 1 COORNAKE AVE., FLEMINGBORO, WV 26415
 PH. 800-452-2248
 EXTRUDED NON-IMPACT VINYL MULLIONS
 WITH ALUMINUM REINFORCEMENT
 ALL NON-IMPACT WINDOW SERIES

MULLIONS MEET THE REQUIREMENTS OF THE 2010
 FLORIDA BUILDING CODE.

REVISIONS

REV.	DESCRIPTION	DATE	BY
1	REVISED WORKING AT CHARTS	4/4/2007	GLS
2	REMOVED SHEET B FROM BUILDING	12/15/2008	TDD
3	REMOVED SHEET B FROM BUILDING	04/15/2011	JRM
4	REMOVED SHEET B FROM BUILDING	01/20/2012	CAP
5	Code updated general notes sheet 1.1. Updated DP rollings chart and added new mullion covers.	08/20/2012	T.D.D.

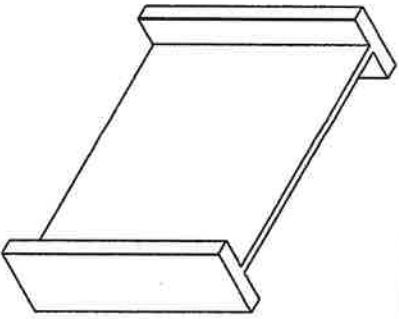

LARGE MULLION
 REINFORCEMENT #CM0146
 ALUMINUM 6063-T6

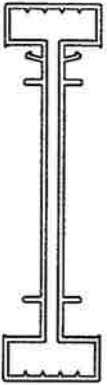

5000 FIN & J FRAME VINYL
 H-MULLION COVER #VPI-573
 EXTRUDED VINYL 0.071" MIN.

- PRODUCT DESCRIPTION:
 1. ALL MULLION REINFORCEMENTS ARE EXTRUDED ALUMINUM 6063-T6.
 2. ALL MULLION COVERS ARE EXTRUDED VINYL. SEE ABOVE FOR INDIVIDUAL MULLION THICKNESS.

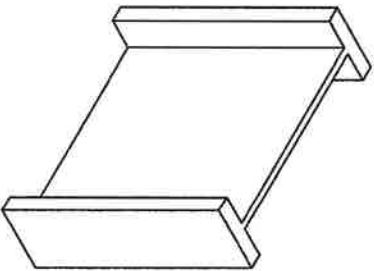

LARGE MULLION
 REINFORCEMENT #16991
 ALUMINUM 6063-T6



PROFINISH LARGE VINYL
 H-MULLION COVER #VPI-560
 EXTRUDED VINYL 0.079" MIN.

RETROFIT LARGE VINYL
 H-MULLION COVER #VPI-354
 EXTRUDED VINYL 0.071" MIN.

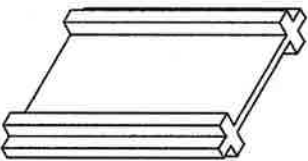
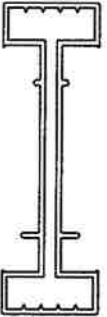

MEDIUM MULLION
 REINFORCEMENT #16990
 ALUMINUM 6063-T6



PROFINISH MEDIUM VINYL
 H-MULLION COVER #VPI-346A
 EXTRUDED VINYL 0.071" MIN.

4000 SERIES MEDIUM VINYL
 H-MULLION COVER #MP0347
 EXTRUDED VINYL 0.070" MIN.

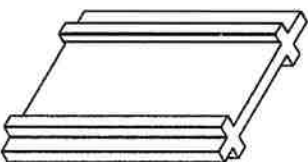
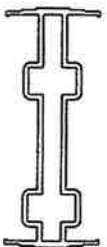

MEDIUM MULLION
 REINFORCEMENT #20634
 ALUMINUM 6063-T6

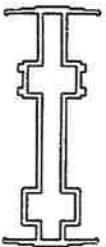

RETROFIT MEDIUM VINYL
 H-MULLION COVER #VPI-436
 EXTRUDED VINYL 0.070" MIN.

TABLE OF CONTENTS

SHT	DESCRIPTION
1	INDIVIDUAL MULLION APPLICATIONS
2	DESIGN PRESSURES FOR REINFORCEMENT CM0146
3	DESIGN PRESSURES FOR REINFORCEMENT 16991
4	DESIGN PRESSURES FOR REINFORCEMENT 16990
5	DESIGN PRESSURES FOR REINFORCEMENT 20634
6	MULLION ATTACHMENT AND ANCHORING
7	MULLION CROSS SECTIONS-WOOD FRAME SUBSTRATE
8	MULLION CROSS SECTIONS-MASONRY/CONC. SUBSTRATE



4000 SERIES LARGE VINYL
 H-MULLION COVER #VPI-354A
 EXTRUDED VINYL 0.071" MIN.

GENERAL NOTES:

1. THE FOUR (4) MULLION PRODUCTS MEET THE 2010 FLORIDA BUILDING CODE (FBC) SECTION 1715.5.5, INCLUDING L/175 DEFLECTION LIMIT, LOAD TRANSFER, AND FIBERSTRESS ANALYSES IN THE DESIGN PRESSURES SHOWN IN THE TABLES IN THIS DRAWING. THE ANALYSES DID NOT ADDRESS AIR OR WATER INFILTRATION. OVERALL WINDOW ASSEMBLY ALLOWABLE DESIGN PRESSURES SHALL BE THE LOWER OF THE MULLION PER THIS APPROVAL OR THE SIMONTON WINDOWS PER SEPARATE PRODUCT APPROVAL.
 2. PRODUCT ANCHORS SHALL BE AS LISTED AND SPACED AS SHOWN HEREIN.

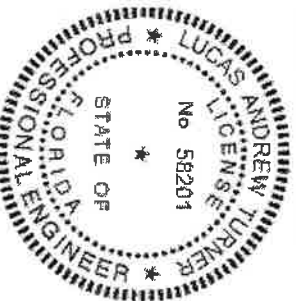

72

9/29/2012
 SIMONTON
 1000 W. STATE ST. SUITE 100
 FLEMINGBORO, WV 26415
 PH. 800-452-2248
 FAX. 304-645-2248
 WWW.SIMONTON.COM

Lucas Turner
 2012-06-24 14:26:04:00

EXTRUDED NON-IMPACT VINYL MULLIONS WITH ALUMINUM REINFORCEMENT ALL NON-IMPACT WINDOW SERIES

SIMONTON
 1 COCKRAVE AVE. FLEMING, WV 26410
 TEL. 800-459-2288

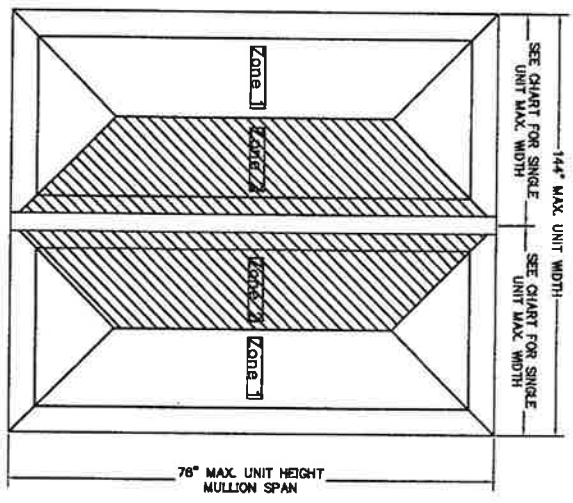

WINDOW TYPE	WINDOW WIDTH
DOUBLE HUNG	56"
HORIZONTAL SLIDER	72"
CASEMENT	36"
FIXED	96"

MAXIMUM SINGLE WINDOW WIDTH
 MULLION TRIBUTARY WIDTH = SUM OF ZONE 2 WINDOW WIDTHS

REVISIONS		
REV.	DESCRIPTION	DATE
1	REVISED WORKING AT CHARTS (SHEETS 2 - 5)	4/4/2007
2	Revised Per 2007 Florida Building Code, Added Sheet 7.	12/15/2008
3	Revised Per 2007 Florida Building Code, Added Sheet 8.	04/15/2011
4	Revised Per 2010 Florida Building Code, updated general notes sht.1	01/20/2012
5	Updated Dp ratings chart and added new mullion covers.	06/20/2012

TABLE A - MAXIMUM DESIGN PRESSURES (PSF) MULLION # CM0146

Mullion Length	Individual Unit Width																		
	24	28	32	36	40	44	48	52	56	60	64	68	72	76	80	84	88	92	96
40	75	76	77	78	79	80	81	82	83	84	85	86	87	88	89	90	91	92	93
41	75	76	77	78	79	80	81	82	83	84	85	86	87	88	89	90	91	92	93
48	75	76	77	78	79	80	81	82	83	84	85	86	87	88	89	90	91	92	93
52	75	76	77	78	79	80	81	82	83	84	85	86	87	88	89	90	91	92	93
56	75	76	77	78	79	80	81	82	83	84	85	86	87	88	89	90	91	92	93
60	75	76	77	78	79	80	81	82	83	84	85	86	87	88	89	90	91	92	93
64	75	76	77	78	79	80	81	82	83	84	85	86	87	88	89	90	91	92	93
68	75	76	77	78	79	80	81	82	83	84	85	86	87	88	89	90	91	92	93
72	75	76	77	78	79	80	81	82	83	84	85	86	87	88	89	90	91	92	93
76	75	76	77	78	79	80	81	82	83	84	85	86	87	88	89	90	91	92	93
80	75	76	77	78	79	80	81	82	83	84	85	86	87	88	89	90	91	92	93
84	75	76	77	78	79	80	81	82	83	84	85	86	87	88	89	90	91	92	93
88	75	76	77	78	79	80	81	82	83	84	85	86	87	88	89	90	91	92	93
92	75	76	77	78	79	80	81	82	83	84	85	86	87	88	89	90	91	92	93
96	75	76	77	78	79	80	81	82	83	84	85	86	87	88	89	90	91	92	93

ALL FIN & J FRAMES H-MULLION
 LARGE VINYL MULLION COVER #VPI-573
 EXTRUDED VINYL .071" MIN.

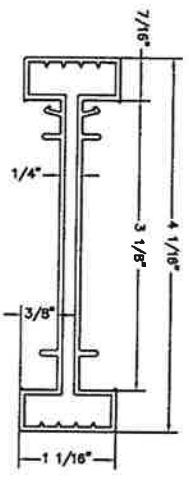

LARGE MULL REINFORCEMENT #CM0146
 ALUMINUM 6063-T6

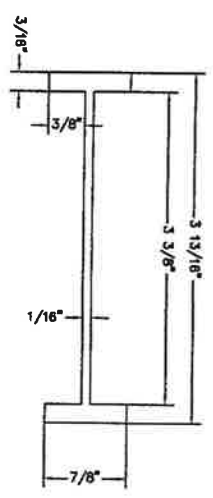

SEE NOTES SHEETS 6, 7, AND 8 FOR REQUIRED ANCHORAGE INFORMATION.

22

SIMONTON
 1 COCKRAVE AVE. FLEMING, WV 26410
 TEL. 800-459-2288
 FAX. 304-725-2288
 WWW.SIMONTON.COM

REVISIONS
 1. 01/20/12
 2. 04/15/11
 3. 12/15/08
 4. 04/04/07

SIMONTON
 1 COOPERATE PL. SUITE 200
 FAYETTEVILLE, NC 28418

**EXTRUDED NON-IMPACT VINYL MULLIONS
 WITH ALUMINUM REINFORCEMENT
 ALL NON-IMPACT WINDOW SERIES**

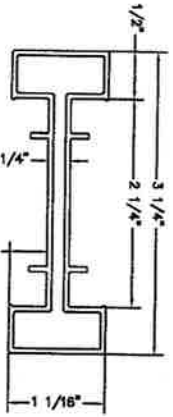
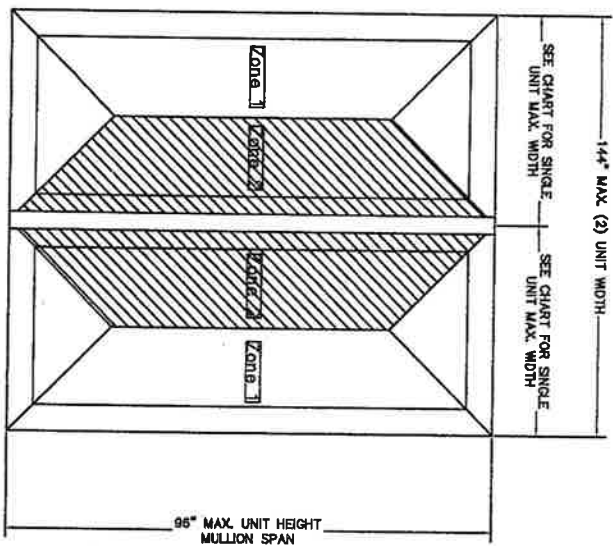

**PROFINISH H-MULLION
 LARGE VINYL MULLION COVER #VPI-560
 EXTRUDED VINYL .079\"/>**

MAXIMUM SINGLE WINDOW WIDTH

WINDOW TYPE	WINDOW WIDTH
SINGLE HUNG	52"
DOUBLE HUNG	56"
HORIZONTAL SLIDER	72"
CASEMENT	36"
FIXED	96"

MULLION TRIBUTARY WIDTH = SUM OF ZONE 2 WINDOW WIDTHS

SEE NOTES SHEETS 6, 7, AND 8 FOR REQUIRED ANCHORAGE INFORMATION.

**TABLE B - MAXIMUM DESIGN PRESSURES (PSF)
 MULLION #16991**

Mullion Length	Individual Unit Width																		
	24	28	32	36	40	44	48	52	56	60	64	68	72	76	80	84	88	92	96
40	75	75	75	75	75	75	75	75	75	75	75	75	75	75	75	75	75	75	75
44	75	75	75	75	75	75	75	75	75	75	75	75	75	75	75	75	75	75	75
48	75	75	75	75	75	75	75	75	75	75	75	75	75	75	75	75	75	75	75
52	75	75	75	75	75	75	75	75	75	75	75	75	75	75	75	75	75	75	75
56	75	75	75	75	75	75	75	75	75	75	75	75	75	75	75	75	75	75	75
60	75	75	75	75	75	75	75	75	75	75	75	75	75	75	75	75	75	75	75
64	75	75	75	75	75	75	75	75	75	75	75	75	75	75	75	75	75	75	75
68	75	75	75	75	75	75	75	75	75	75	75	75	75	75	75	75	75	75	75
72	75	75	75	75	75	75	75	75	75	75	75	75	75	75	75	75	75	75	75
76	75	75	75	75	75	75	75	75	75	75	75	75	75	75	75	75	75	75	75
80	75	75	75	75	75	75	75	75	75	75	75	75	75	75	75	75	75	75	75
84	75	75	75	75	75	75	75	75	75	75	75	75	75	75	75	75	75	75	75
88	75	75	75	75	75	75	75	75	75	75	75	75	75	75	75	75	75	75	75
92	75	75	75	75	75	75	75	75	75	75	75	75	75	75	75	75	75	75	75
96	75	75	75	75	75	75	75	75	75	75	75	75	75	75	75	75	75	75	75

REVISIONS

REV.	DESCRIPTION	DATE	BY
1	REVISED WORDING AT CHARTS (SHEETS 2-5)	4/4/2007	GLS
2	Revised per 2007 Florida Building Code, Added Sheet 7.	12/15/2008	TDD
3	Revised per 2007 Florida Building Code, Added Sheet 8.	04/15/2011	JRM
4	Revised per 2010 Florida Building Code, updated general notes sht.1.	01/20/2012	CAP
5	Updated DP ratings chart and added new mullion covers.	06/20/2012	T.D.D.

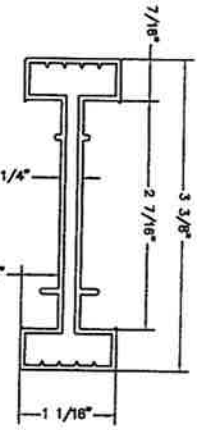

**RETROFIT H-MULLION
 LARGE VINYL MULLION COVER #VPI-354
 EXTRUDED VINYL .071\"/>**

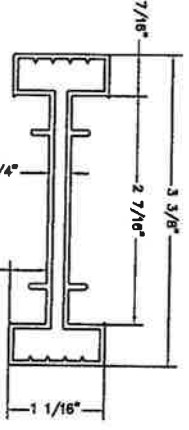

**4000 SERIES RETROFIT H-MULLION
 LARGE VINYL MULLION COVER #VPI-354
 EXTRUDED VINYL .071\"/>**

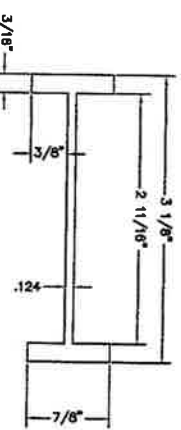

**LARGE MULL REINFORCEMENT #16991
 ALUMINUM 6063-T6**

7-2

0.000/2004

SIMONTON

1000 S. JAMES ST. SUITE 200
 FAYETTEVILLE, NC 28418
 704.785.1111
 WWW.SIMONTON.COM

REVISED VINYL MULLIONS

DATE: 07/20/12

BY: TDD

SIMONTON
 1 DOORWAY AVE., PINEBURG, WY 28416
 FL 80-48-2216
 EXTRUDED NON-IMPACT VINYL MULLIONS
 WITH ALUMINUM REINFORCEMENT
 ALL NON-IMPACT WINDOW SERIES

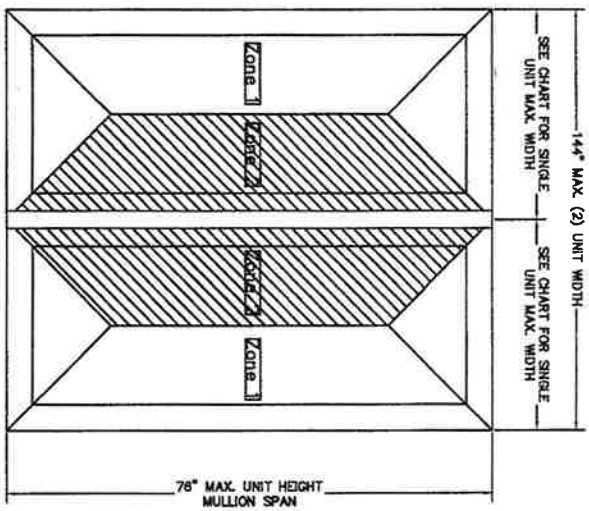

MAXIMUM SINGLE WINDOW WIDTH	
WINDOW TYPE	WINDOW WIDTH
SINGLE HUNG	52"
DOUBLE HUNG	56"
HORIZONTAL SLIDER	72"
CASEMENT	56"
FIXED	96"

MULLION TRIBUTARY WIDTH = SUM
 OF ZONE 2 WINDOW WIDTHS

REVISIONS			
REV.	DESCRIPTION	DATE	BY
1	REVISED WORDING AT CHARTS (SHEETS 2-5)	4/4/2007	GLS
2	Revised Per 2007 Florida Building Code, Added Sheet 7.	12/15/2008	TDD
3	Revised Per 2007 Florida Building Code, Added Sheet 8.	04/15/2011	JRM
4	Revised Per 2010 Florida Building Code, updated general notes and updated DP ratings chart and added new mullion covers.	01/20/2012	CAP
5	Updated DP ratings chart and added new mullion covers.	06/20/2012	T.D.D.

TABLE C - MAXIMUM DESIGN PRESSURES (PSF)
 MULLION #16990

Mullion Length	Individual Unit Width														
	24	28	32	36	40	44	48	52	56	60	64	68	72		
40	75	75	75	75	75	75	75	75	75	75	75	75	75		
44	75	75	75	75	75	75	75	75	75	75	75	75	75		
48	75	75	75	75	75	75	75	75	75	75	75	75	75		
52	75	75	75	75	75	75	75	75	75	75	75	75	75		
56	75	75	75	75	75	75	75	75	75	75	75	75	75		
60	75	75	75	75	75	75	75	75	75	75	75	75	75		
64	60	50	45	40	35	30	25	20	15	15	15	15	15		
68	60	50	45	40	35	30	25	20	15	15	15	15	15		
72	40	35	30	25	20	15	15	15	15	15	15	15	15		
76	35	30	25	20	15	15	15	15	15	15	15	15	15		

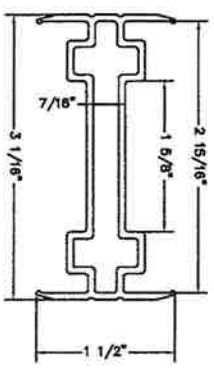

MEDIUM H-MULLION VINYL COVER #V346A
 ALL NEW CONSTRUCTION
 EXTRUDED VINYL .071" MIN.

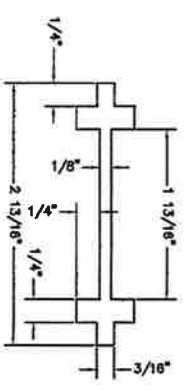

MEDIUM MULL REINFORCEMENT #16990
 ALUMINUM 6063-T6

SEE NOTES SHEETS 6, 7, AND 8 FOR REQUIRED ANCHORAGE INFORMATION.

SIMONTON
 1 DOORWAY AVE., PINEBURG, WY 28416
 FL 80-48-2216
 8/20/2012
 SIMONTON 15
 15-20-08
 10/20/08
 10/20/12
 10/20/12

**EXTRUDED NON-IMPACT VINYL MULLIONS
WITH ALUMINUM REINFORCEMENT
ALL NON-IMPACT WINDOW SERIES**

SIMONTON
1 COOKRAVE AVE. POKESONNO, WI 53418
PH. 500-428-2246

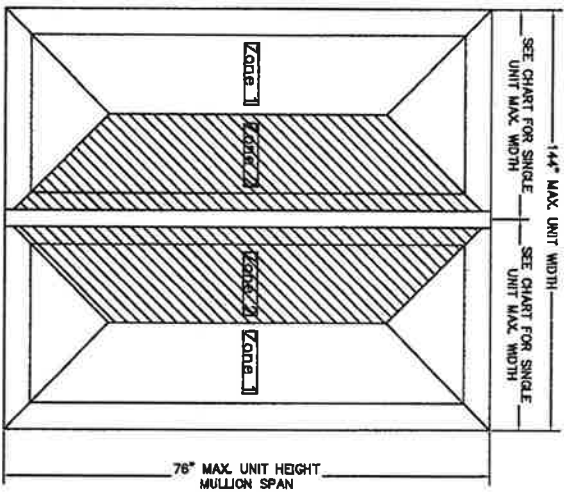

WINDOW TYPE	WINDOW WIDTH
DOUBLE HUNG	56"
HORIZONTAL SLIDER	72"
CASEMENT	36"
FIXED	96"

MAXIMUM SINGLE WINDOW WIDTH
MULLION TRIBUTARY WIDTH = SUM
OF ZONE 2 WINDOW WIDTHS

**TABLE D - MAXIMUM DESIGN PRESSURES (PSF)
MULLION # 20634**

Mullion Length	Individual Unit Width														
	24	28	32	36	40	44	48	52	56	60	64	68	72	76	80
40	75	75	75	75	75	75	75	75	75	75	75	75	75	75	75
44	75	75	75	75	75	75	75	75	75	75	75	75	75	75	75
48	75	75	75	75	75	75	75	75	75	75	75	75	75	75	75
52	75	75	75	75	75	75	75	75	75	75	75	75	75	75	75
56	75	75	75	75	75	75	75	75	75	75	75	75	75	75	75
60	75	75	75	75	75	75	75	75	75	75	75	75	75	75	75
64	75	75	75	75	75	75	75	75	75	75	75	75	75	75	75
68	75	75	75	75	75	75	75	75	75	75	75	75	75	75	75
72	75	75	75	75	75	75	75	75	75	75	75	75	75	75	75
76	75	75	75	75	75	75	75	75	75	75	75	75	75	75	75

REVISIONS			
REV.	DESCRIPTION	DATE	BY
1	REVISED WORDING AT CHARTS (SHEETS 2-5)	4/4/2007	GLS
2	Revised per 2007 Florida Building Code, Added Sheet 7.	12/15/2008	TDD
3	Revised per 2007 Florida Building Code, Added Sheet 8.	04/15/2011	JRM
4	Revised Per 2010 Florida Building Code, updated general notes sheet 1.	01/20/2012	CAP
5	Updated DP ratings chart and added new mullion covers.	06/20/2012	T.D.D.

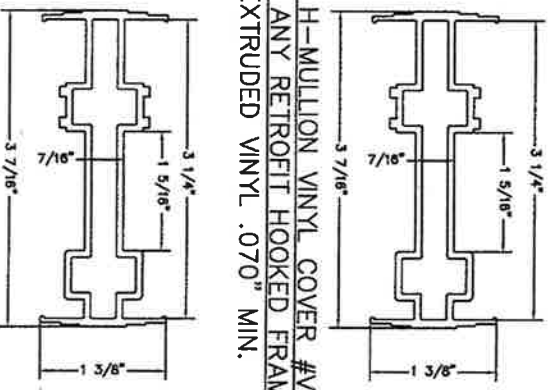

MEDIUM H-MULLION VINYL COVER #VPI-436
FOR ANY RETROFIT HOOKED FRAME
EXTRUDED VINYL .070" MIN.

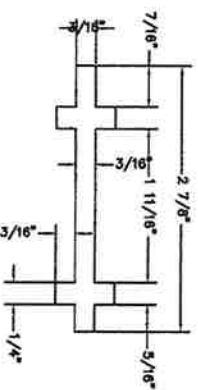

MEDIUM MULL REINFORCEMENT #20634
ALUMINUM 6063-T6

MEDIUM H-MULLION VINYL COVER #VPI-436
FOR ANY RETROFIT HOOKED FRAME
EXTRUDED VINYL .070" MIN.

SEE NOTES SHEETS 6, 7, AND 8 FOR REQUIRED ANCHORAGE INFORMATION.

8/21/2012
LUCAS A. SIMONTON, P.E., 1500 W. STATE ST., SUITE 100, MILWAUKEE, WI 53233
PH. 414.224.2246 FAX 414.224.2247
WWW.SIMONTON.COM
REVISIONS
1 11/15/07
2 12/15/08
3 04/15/11
4 01/20/12
5 06/20/12

SIMONTON
EXTRUDED VINYL MULLIONS

SIMONTON
 1 COSSAWE AVE. SIMONSON, WV 26105
 PH. 800-458-2208

**EXTRUDED NON-IMPACT VINYL MULLIONS
 WITH ALUMINUM REINFORCEMENT
 ALL NON-IMPACT WINDOW SERIES**

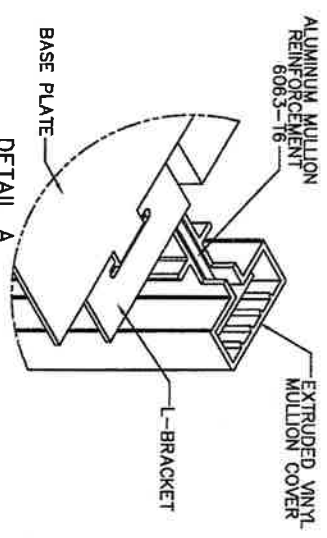

REVISIONS

REV.	DESCRIPTION	DATE	BY
1	REVISED WORDING AT CHARTS (SHEETS 2-5)	4/4/2007	GLS
2	Revised per 2007 Florida Building Code, Added Sheet 7.	12/15/2008	TDD
3	Revised per 2007 Florida Building Code, Added Sheet 8.	04/15/2011	JRM
4	Revised per 2010 Florida Building Code, updated general notes and added new mullion covers.	01/20/2012	CAP
5	Updated DP ratings chart and added new mullion covers.	06/20/2012	T.D.D.

SEE MANUFACTURER'S INSTALLATION INSTRUCTIONS FOR ATTACHING REINFORCED MULLIONS TO WINDOW UNITS. TYPICALLY USE SELF-TAPPING SCREW OF SUFFICIENT LENGTH TO FULLY ENGAGE THREADS THROUGH THE ALUMINUM REINF. AT THE ANCHOR SIZE AND SPACING INDICATED IN THE APPLICABLE WINDOW PRODUCT APPROVAL FOR ATTACHMENT TO WOOD SUBSTRATE.

L-BRACKET IS ATTACHED TO VINYL MULLION COVER AND MULLION REINFORCEMENT USING (2) RIVETS OR BARREL NUTS (305 LB. MAX. SHEAR) 2 PLACES EACH L-BRACKET (REFER TO TABLE 1)

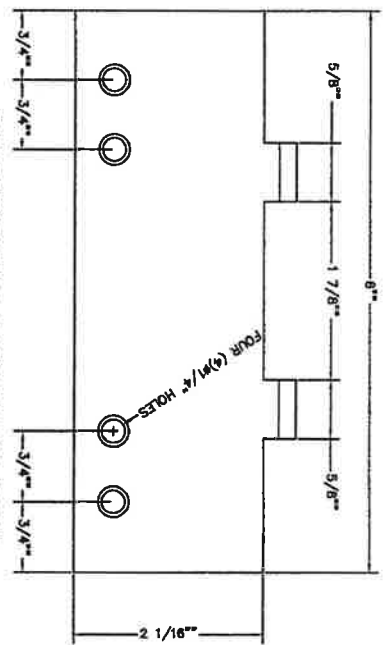

REINFORCEMENT BASE PLATE DETAIL
 .060" MIN. STAINLESS STEEL
 ANSI 302/304

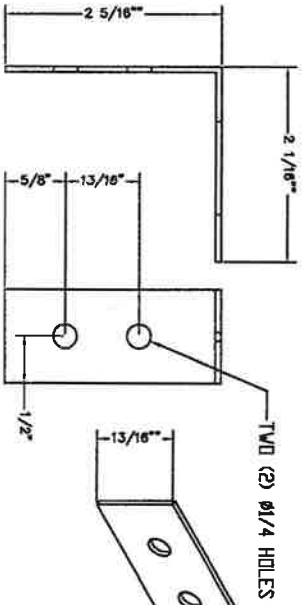

REINFORCEMENT L-BRACKET
 0.076" MIN. STAINLESS STEEL
 ANSI 302/304



ASSEMBLED MULLION ATTACHMENT VIEW

TABLE 1 - MULLION ATTACHING HARDWARE

RIVET	.25 DIA. STEEL RIVET WITH A GRIP LENGTH OF .50 MAX.
BARREL NUT	#10-24 OR #10-32 STAINLESS STEEL BARREL NUT. 250 O.D. X .25" LG WITH .125 MIN ENGAGEMENT

- NOTES:**
- WOOD FRAME: USE (4) #10 X 1 3/4" WOOD SCREWS AT THE HEAD AND SILL THROUGH BASE PLATES, WITH 1-1/2" MINIMUM EMBEDMENT INTO WOOD FOR MULLION ATTACHMENT. SEE SHEET 7 FOR DETAILS.
 - MASONRY/CONCRETE: USE (2) 1" W. ADVANCED THREADFORM TECHNOLOGY TAPCON ANCHORS AT HEAD AND SILL THROUGH BASE PLATES, WITH 1" MIN. EMBEDMENT FOR CMU, AND 1 1/2" MINIMUM EMBEDMENT FOR CONCRETE FOR MULLION ATTACHMENT. SEE SHEET 8 FOR DETAILS.
 - TWO (2) RIVETS OR BARREL NUTS ARE REQUIRED TO ATTACH L-BRACKETS TO ALUMINUM MULLION. SEE TABLE 1 (THIS SHEET).

DATE: 07/10/08
 DRAWN BY: JRM
 CHECKED BY: JRM
 APPROVED BY: JRM
 PROJECT: 07-01-08
 SHEET: 1 OF 3
 TITLE: REINFORCED VINYL MULLIONS

SIMONTON

SIMONTON
 1 COOPER AVE. ROSELAND, WV 26415
 PH. 800-488-2210
**EXTRUDED NON-IMPACT VINYL MULLIONS
 WITH ALUMINUM REINFORCEMENT
 ALL NON-IMPACT WINDOW SERIES**

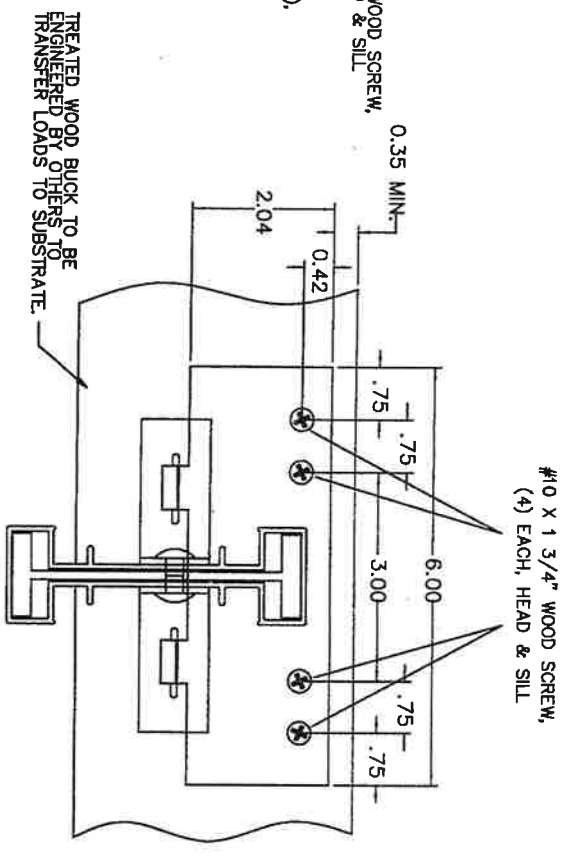
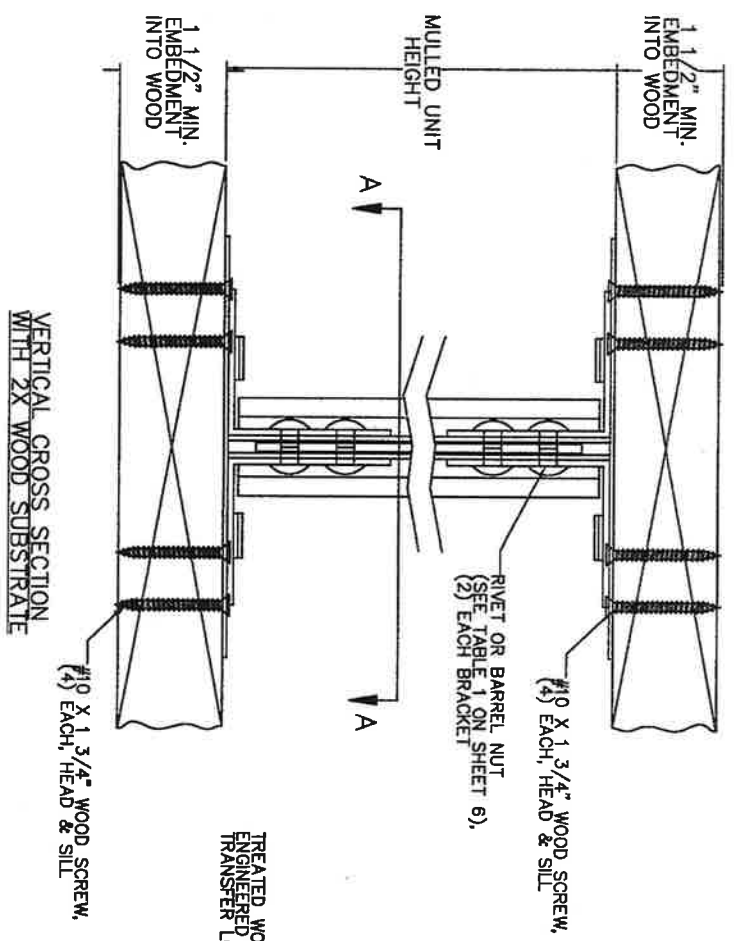

REVISIONS			
REV.	DESCRIPTION	DATE	BY
1	REVISED WORKING AT CHARTS	4/4/2007	GLS
2	Revised per 2007 Florida Building Code, Added Sheet 7	12/15/2008	TDD
3	Revised per 2007 Florida Building Code, Added Sheet B	04/15/2011	JRM
4	Revised per 2010 Florida Building Code, updated general notes sheet 1, updated DP rollings chart and added new mullion covers.	01/20/2012	CAP
5		06/20/2012	T.D.D.

- NOTES:
1. THE MULLION PRODUCTS AND THEIR INSTALLATION COMPLY WITH THE 2010 FBC STRUCTURAL REQUIREMENTS AND ARE LIMITED TO USE OUTSIDE THE HVAHZ.
 2. THE MULLIONS SHALL BE USED IN CONNECTION WITH FBC APPROVED PRODUCTS.
 3. ANCHORS SHALL HAVE 1 1/2" MINIMUM EMBEDMENT INTO WOOD AND 7/8" MINIMUM WOOD EDGE DISTANCE.
 4. ATTACHMENT OF ALL 2X TREATED WOOD BUICKS SHALL BE ENGINEERED SEPARATELY BY OTHERS.
 5. WOOD SHALL BE TREATED 2X SPRUCE, PINE, OR FIR.
 6. #10 WOOD SCREWS SHALL BE STEEL CONFORMING TO ASTM A 653.
 7. BASE PLATES AND L-BRACKETS ARE STAINLESS STEEL CONFORMING TO ANSI 302/304.
 8. SIMILAR INSTALLATIONS ARE USED ON HEAD AND SILL.
 9. WHEN INSTALLED IN LOCATIONS WHERE WINDBORNE DEBRIS PROTECTION IS REQUIRED, USE OF AN IMPACT PROTECTIVE SYSTEM IS REQUIRED.

22

6/27/2012

SIMONTON

1000 S. SANDERS ST. COVINGTON, LA 70421
 713-885-2210
 WWW.SIMONTON.COM

REVISED WORKING AT CHARTS

DATE: 07/20/12

BY: T.D.D.

**EXTRUDED NON-IMPACT VINYL MULLIONS
WITH ALUMINIUM REINFORCEMENT
ALL NON-IMPACT WINDOW SERIES**

SIMONTON
1 COOKSME AVE. PENNSBORO, WV 26418
PH. 800-438-2248

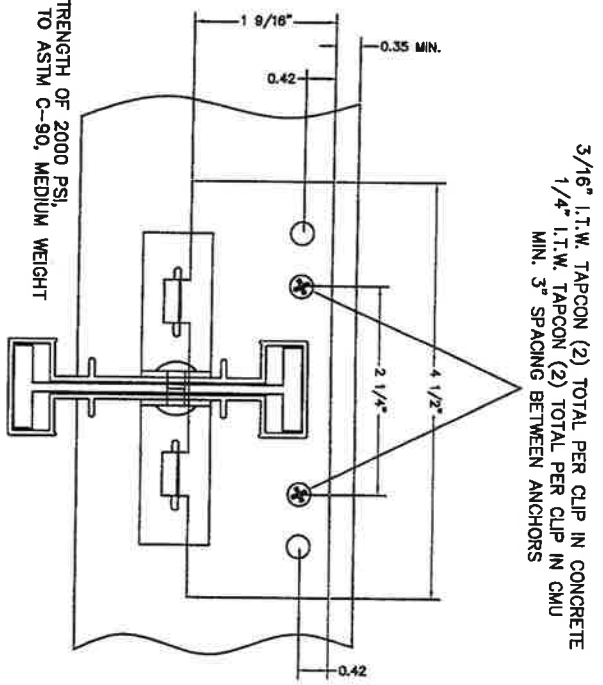
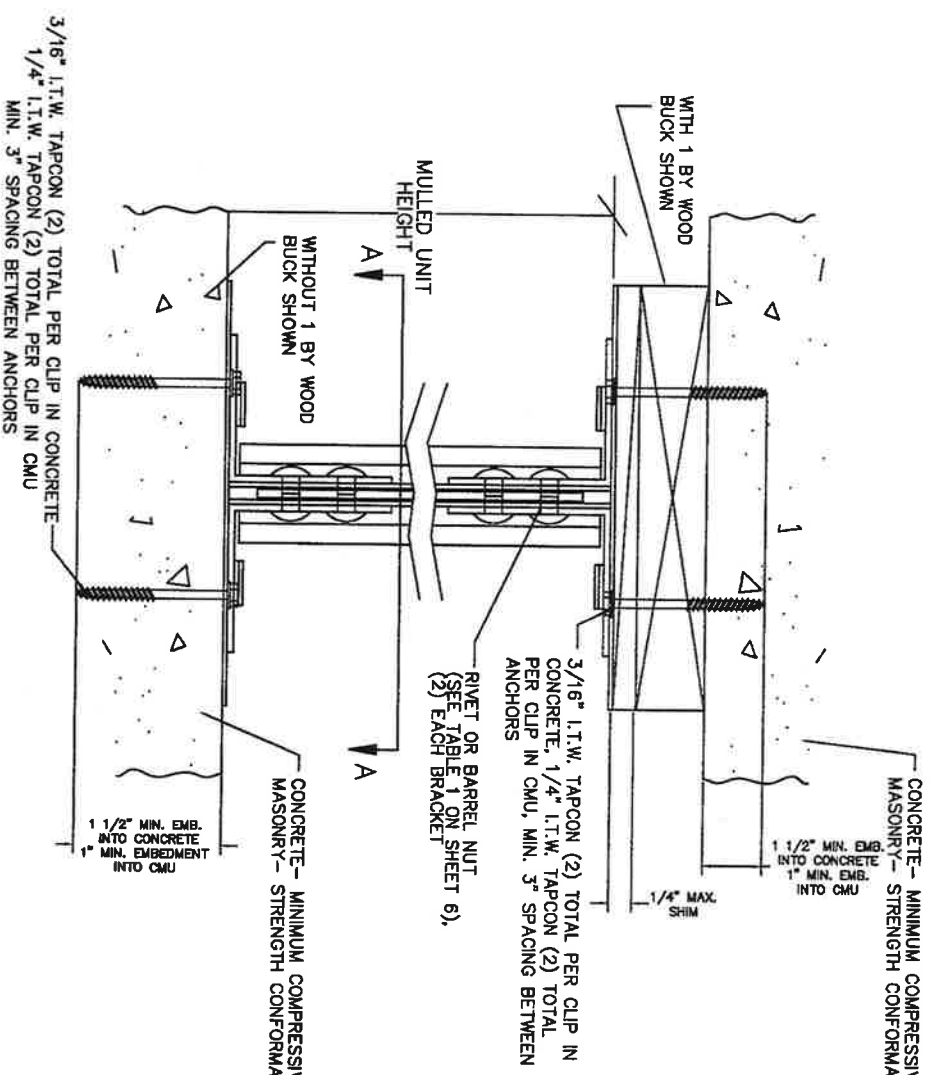

SECTION A-A

REVISIONS			
REV.	DESCRIPTION	DATE	BY
1	REVISED WORDING AT CHARTS	4/4/2007	GLS
2	REVISED PER ADD'D/STAYING BUILDING CODES, 2000 / SHEET 7.	12/15/2008	TDD
3	REVISED PER ADD'D/STAYING BUILDING CODES, 2010 / SHEET 8	04/15/2011	JRM
4	REVISED PER 2010 Florida Building Code, updated general notes and added DP ratings chart and added new mullion covers.	01/20/2012	CAP
5		06/20/2012	T.D.D.

**VERTICAL CROSS SECTION WITH
MASONRY/CONCRETE SUBSTRATE**

- NOTES:
1. THE MULLION PRODUCTS AND THEIR INSTALLATION COMPLY WITH THE 2010 FBC STRUCTURAL REQUIREMENTS AND ARE LIMITED TO USE OUTSIDE THE HW42.
 2. THE MULLIONS SHALL BE USED IN CONNECTION WITH FBC APPROVED PRODUCTS.
 3. ANCHORS SHALL HAVE 1" MINIMUM EMBEDMENT & 2" MINIMUM EDGE DISTANCE FOR CMU BLOCK, AND 1 1/2" MINIMUM EMBEDMENT & 1 1/8" MINIMUM EDGE DISTANCE FOR CONCRETE.
 4. ATTACHMENT OF ALL 2X TREATED WOOD BUCKS SHALL BE ENGINEERED SEPARATELY BY OTHERS.
 5. WOOD SHALL BE TREATED 2X SPRUCE, PINE, OR FIR.
 6. L.T.W. ADVANCED THREADFORM TECHNOLOGY TAPCONS OR EQUAL SHALL BE GRADE 5 HEAT TREATED STEEL.
 7. BASE PLATES AND L-BRACKETS ARE STAINLESS STEEL CONFORMING TO ANSI 302/304.
 8. SIMILAR INSTALLATIONS ARE USED ON HEAD AND SILL.
 9. WHEN INSTALLED IN LOCATIONS WHERE WINDBORNE DEBRIS PROTECTION IS REQUIRED, USE OF AN IMPACT PROTECTIVE SYSTEM IS REQUIRED.

	<p>DATE: 06/20/2012</p> <p>SCALE: 0.75"=1"</p> <p>PROJECT: ALL MULLION PRODUCTS FROM PENNSBORO, WV</p>	<p>BY: TDD</p> <p>DATE: 12/15/08</p> <p>DATE: 04/15/2011</p> <p>DATE: 01/20/2012</p> <p>DATE: 06/20/2012</p>
--	--	--

3417 WATZOW PARK DRIVE
TALLAHASSEE, FL 32312

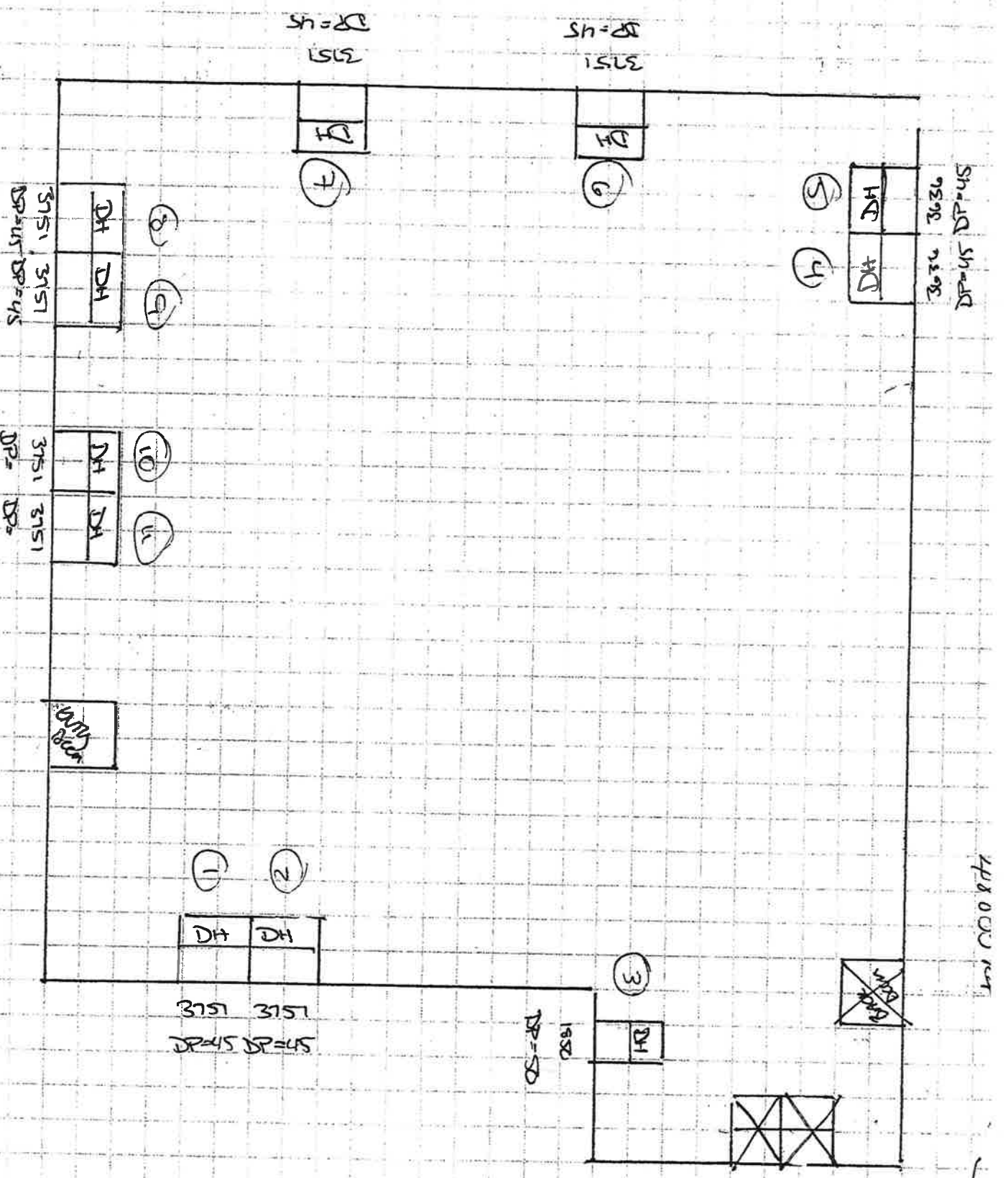

41800 NW
418855

Name: MARY MCNEULT, EXECUTOR # H: Tel# 407 473-3253 Email: oremenu HD@gmail.com
I/We, the owner(s) of the premises described below, hereinafter referred to as "Buyer" offer to contract with FAS Windows & Doors, hereinafter referred to as "FASWD" to furnish all materials listed below for use at the premises located at: Is there a Homeowners Association? Yes No

3417 WINTER PARK DRIVE (Street) BOULDER (City) FL (State) 32812 (Zip)

Congratulations on your purchase of the finest home improvement products in the industry today! Below are the names and contact information of key people involved with your purchase. We believe that communication is the pathway to success! Please contact the people below at any time regarding your purchase and/or installation

Installation

You will be contacted by a member of your Installation Team to discuss the following:

1. Confirm receipt of your contract and review specifications.
2. Schedule a time for the tight measure.
3. Identify an approximate installation start or delivery date.
4. Answer any concerns you may have related to the project.

Customer Care

In the event that you have any questions or concerns regarding the window or door installation, please do not hesitate to contact Jimmy McLean, your Production Coordinator, or Tommy Mulvaney, your Production Manager, at 407-770-0184. If you feel that we did not deliver on any of our promises to you, please contact us at 407-770-0184.

Install Pick Up Delivery Low-E Mixed Impact Mixed

Quantity	Manufacturer	Series	Style	Color	Grids	Screens	Obscure/ Temper	Line Notes
11	SIMONEN	SOSU	DH	WH	N/A	1/2		
2								
3								
4								

*Please note all grid specifications, finish, hardware, trim and hinge details in line notes.

Special Instructions:

THIS ORDER INCLUDES (11) DOUBLE-HINGE SIMONEN REFLECTORS SOSU WINDOWS. PRICE INCLUDES INSTALLATION / REMOVAL / FINISH / PAINT / TAPES / SITE PREP / LABOUR. MOUNTING TO MATCH MANUFACTURER'S WARRANTY - 1950'S HOME. NEEDS LEAD PAINT TESTING. POSITIVE RESULTS INCLUDES PAINT @ \$50.00 PER WINDOW.

Please read the following bold type and initial corresponding line.

BHI doors are non-finished. Failure to paint or stain doors in a timely manner may affect your rights under the manufacturer's warranty.

Not Applicable Buyer initials: _____

Verbal understandings and agreements with representative shall not be binding. All understandings and agreements must be set forth in writing in this Contract. Understand and recognize all terms and conditions on the front and reverse of this contract and am initialing to indicate my complete understanding.

Buyer initials: _____

HURRICANE PROTECTION I acknowledge that I am the owner of the residence and have contracted with FASWD to replace windows/doors. The home is located in an impact zone and I have existing hurricane protection equipment that complies with local jurisdiction. FASWD will not be liable if my existing protection equipment is deemed inadequate by the local government inspector after my windows are installed. In the event that my hurricane protection equipment fails inspection, I understand that FASWD will supply appropriate materials at a cost to me of \$375.00 per opening. I am initialing to indicate my complete understanding.

Not Applicable Buyer initials: _____

NOTE: The warranty provisions as stated on the reverse have been explained and I/We understand them fully. Additional provisions and warranties are stated on the reverse side and are part of this contract.

Buyer initials: _____

The TOTAL PRICE for all Labor & Materials (including any applicable discount) is
Terms: Credit (Subject to the approval of the Credit Department)
Credit Approval Code: _____
 Credit Card (Please fill out credit card information sheet)
 Cash (Final Payment payable to Installer upon completion)

SUB TOTAL: 6725.00
TAX (DELIVERY OR PICK UP ONLY): _____
GRAND TOTAL: 6725.00
DEPOSIT REQUIRED: 3362.50
BALANCE DUE: 3362.50

If this is a credit transaction, the agreement for credit is contained in a separate document which is incorporated herein by reference and made a part hereof. IN WITNESS WHEREOF Buyer(s) have hereunto signed their name(s) this _____ day of _____, 20____, and acknowledge receipt of a true copy of this Contract and unless otherwise specified, it is understood that the Buyer is ready for work to begin.

You, the Buyer(s), may cancel this transaction at any time prior to midnight of the third day after the date of this transaction. Signature affixed below acts as a receipt that buyer(s) received appropriate cancellation forms. See reverse side for details.

FASWD
SUBMITTED BY: Representative _____ Date 2/9/15
APPROVED BY: Sales Manager _____ Date _____

BUYER
BUYER: MP Mcneult Date 5 Feb 2015
BUYER: Executor Date _____

Buyer(s) understands that this document does not constitute a valid and binding Contract for any purpose unless and until it is signed and accepted by an authorized representative of FASWD. All amounts due under this agreement shall be paid upon the date specified herein, if so set out, or upon the day the last of the work or products are furnished to the Buyer. Past due amounts are subject to a service charge of 18% per annum from the due date. Buyer agrees to pay FASWD all costs of enforcement or collection, including reasonable attorney fees, whether or not a lawsuit is commenced as a part of the collection process. This Contract and the agreement for credit, if any, shall constitute the entire agreement between the parties, which entire agreement and specifications shall not be altered or modified except by written agreement between the parties hereto.

IN THE EVENT THIS CONTRACT IS NOT ACCEPTED BY FASWD, ANY PAYMENT MADE HEREUNDER SHALL BE REFUNDED TO THE BUYER(S) AND THE CONTRACT SHALL BE NULL AND VOID AND OF NO EFFECT. FASWD IS NOT RESPONSIBLE FOR EXISTING STRUCTURAL DEFECTS, DRY ROT OR CODE VIOLATIONS, REPAIRING, PLASTERING, CARPENTRY AND/OR DECORATING ARE NOT INCLUDED UNLESS SPECIFICALLY CHARGED FOR AND SPECIFIED IN WRITING HEREIN.

Page ___ of ___

Form Code (Production)

Pink Copy (Buyer)