



City of Belle Isle

Universal Engineering Sciences 3532 Maggie Blvd., Orlando, FL 32811
 Tel 407-581-8161 * Fax 407-581-0313 * www.universalengineering.com

PERMIT CARD – PLEASE POST AT JOB SITE

THIS DOCUMENT BECOMES YOUR PERMIT WHEN PROPERLY VALIDATED

Per FBC 105.3.3: An enforcing authority may not issue a building permit for any building construction, erection, alteration, modification, repair or addition unless the permit either includes on its face or there is attached to the permit the following statement: "NOTICE: In addition to the requirements of this permit, there may be additional restrictions applicable to this property that may be found in the public records of this county, and there may be additional permits required from other governmental entities such as water management districts, state agencies, or federal agencies." The issuance of this permit does not grant permission to violate any applicable City, Orange County, State of Florida and/or Federal codes and/or ordinances. Separate permits are required for Signs, Roofing, Electrical, Gas, Plumbing and Mechanical services. This permit becomes VOID if the work authorized is not commenced within 6 months, or is suspended or abandoned for a period of 6 months after commencement. WORK SHALL BE CONSIDERED SUSPENDED IF AN APPROVED INSPECTION HAS NOT BEEN MADE WITHIN A 6 MONTH PERIOD. PERMISSION IS GRANTED TO DO THE FOLLOWING WORK ACCORDING TO THE CONDITIONS HEREON AND THE APPROVED PLANS AND SPECIFICATIONS, SUBJECT TO COMPLIANCE WITH THE ORDINANCES OF THE CITY OF BELLE ISLE, FLORIDA.

Scope of Work: REROOF: 55sq, asphalt shingles

Comments: None

Project Information

Address: 1921 Hoffner Avenue, Belle Isle, FL 32809
 Parcel ID: 18-23-30-3648-00-500
 Property Owner: Hill, Deborah
 Phone Number: 407-657-9524

 Company Name: Roger Facemire (Individual)
 Contractor Name: Facemire, Rober
 License Number: CCC1326094
 Address: 4310 Piermont Court, Orlando, FL 32817
 Phone Number: 407-416-0306

Permit Number: 2015-10-010

Date of Application: 10/08/2014
Date Permit Issued: 10/09/2014

WARNING TO OWNER: "YOUR FAILURE TO RECORD A NOTICE OF COMMENCEMENT MAY RESULT IN YOU PAYING TWICE FOR IMPROVEMENTS TO YOUR PROPERTY. IF YOU INTEND TO OBTAIN FINANCING, CONSULT WITH YOUR LENDER OR AN ATTORNEY BEFORE RECORDING YOUR NOTICE OF COMMENCEMENT." ON THE JOB INSPECTION(S) MUST BE MADE BEFORE PROCEEDING WITH SUBSEQUENT WORK. THIS CARD MUST BE DISPLAYED OUTSIDE AND BE PROTECTED FROM THE WEATHER WHILE BEING VISIBLE FROM THE STREET UNTIL THE FINAL INSPECTIONS HAVE BEEN APPROVED.

BUILDING FEATURES

IMPACT FEES

Traffic \$
 School \$

ZONING FEES

Zoning Fee \$30.00

UNIVERSAL ENG - BUILDING FEES

Boat Dock \$
 Boat House \$
 Building \$
 Demo \$
 Door(s) \$
 Driveway \$
 Electrical \$
 Fence \$
 Gas \$
 Irrigation \$
 Low Voltage \$
 Mechanical \$
 Plumbing \$
 Pool \$
 Roofing \$80.00
 Screen Encl \$
 Shed \$
 Temp Pole \$
 Window(s) \$

SURCHARGE FEES

Surcharge Fee \$2.00
 Surcharge Fee \$2.00

TOTAL FEES \$114.00

Date Paid 10-9-14

CC or Check # 1776

Amount Paid 114.00

The person accepting this permit shall conform to the terms of the application on file and construction shall conform to the requirements of the Florida Building Code (FS 553).

BUILDING INSPECTOR USE ONLY

IF APPLICABLE:

Have Zoning Approval Conditions Been Met? YES NO Have Stormwater Approval Conditions

Been Met? YES NO Silt fencing in place? YES NO Turbidity Barrier in place? YES NO

€ **BUILDING**

1st _____ (Footing/Foundation)
 Survey specific foundation plan must be onsite before slab pour. Approved Plan on Site? ____
 2nd _____ (Slab)
 3rd _____ (Lintel)(Wall Reinforcing on Masonry Building)
 4th _____ (Exterior Framing)(Roof/Wall Sheathing)
 5th _____ (Framing) (To be made after Plumbing/ Mechanical/ Electrical Rough-Ins & Windows/Doors Installed)
 6th _____ (Insulation to be Made After Roof Installed)
 7th _____ (Drywall)
 8th _____ (Sidewalk/Driveway)
 9th _____ (Other)
 10th _____ (Final – After MEP and Other Applicable Finals)

€ **ROOFING** **OSHA APPROVED ACCESS MUST BE MADE AVAILABLE TO INSPECTOR**

1ST ROOFING Deck Nailing/Dry-in/Flashing _____
 2nd ROOFING Covering In-Progress _____
 3rd ROOFING Covering Final _____

€ **PLUMBING** (Pool-Piping, Solar, Irrigation, Water Treatment Equip, Etc...)

€
 1ST _____ (Underground) 2nd _____ (Sewer)
 3rd _____ (Rough-In/Tub Set) 4th _____ (Final)

CHECK APPROPRIATE BOX

€ **GAS** ___ Natural ___ LP € **MECHANICAL** € **ELECTRICAL** € **LOW VOLTAGE**

1st _____ (Rough-In) 2nd _____ (Final)

Inspection requests are to be emailed to BIDScheduling@UniversalEngineering.com; a confirmation email will be sent back to you upon scheduling. Next-Day Inspection requests must be made by 1pm. Please include the following in your request: Permit #, project address, type of inspection, date of the requested inspection, a contact name & a contact phone number. AM or PM may be requested but cannot be guaranteed.

For a copy of your permit, or to check inspection results, please visit <https://universalengineering.sharefile.com>

login ID = cobi@universalengineering.com

password = universal13



City of Belle Isle

Universal Engineering Sciences 3532 Maggie Blvd., Orlando, FL 32811
Tel 407-581-8161 * Fax 407-581-0313 * www.universalengineering.com

received
10-8-14

APPLICATION FOR ROOFING PERMIT

WARNING TO OWNER: YOUR FAILURE TO RECORD A NOTICE OF COMMENCEMENT MAY RESULT IN YOUR PAYING TWICE FOR IMPROVEMENTS TO YOUR PROPERTY. A NOTICE OF COMMENCEMENT MUST BE RECORDED AND POSTED ON THE JOB SITE BEFORE THE FIRST INSPECTION. IF YOU INTEND TO OBTAIN FINANCING, CONSULT WITH YOUR LENDER OR AN ATTORNEY BEFORE RECORDING YOUR NOTICE OF COMMENCEMENT.

DATE OF APPLICATION: 10-8-14 ROOF PERMIT NUMBER 2015-10-010

PLEASE PRINT. The undersigned hereby applies for a permit to make installations as indicated below:

Project Address 1921 Hoffner Ave, Belle Isle, FL 32809 32812

Property Owner Deborah Hill Phone 407 657 9524

Property Owner's Mailing Address 1921 Hoffner Ave City Belle Isle

State FL Zip Code 32809 Parcel Id Number: 18-23-30-3648-00-500

REQUIRED! To obtain this information, please visit <http://www.ocpaf.org/Searches/ParcelSearch.aspx>

Class of Building: Old New Type of Building: Residential Commercial Other

Type of Work: New Roof ReRoof CERTAINTED LANDMARK FI 5444.7

- **REQUIRED!** Florida Product Approval Screen Printout from www.floridabuilding.org showing the Code Version
- **REQUIRED!** Florida Product Approval Installation Instructions from www.floridabuilding.org (not the manufacturer instructions)
- **REQUIRED!** Copies of your General Liability & Worker's Comp Insurance Certificate & State and Local Licenses

Please indicate the nature of work by completing the information below:

Roof Square Footage: 55 Number of Stories: 2 Job Valuation: \$ 12000

Type: Asphalt Shingles Metal Modified Bitumen Other: _____

I hereby certify that the above is true and correct to the best of my knowledge and make Application for Permit as outlined above, and if same is granted I agree to conform to all Florida Building Code Regulations and City Ordinances regulating same and in accordance with plans submitted. The issuance of this permit does not grant permission to violate any applicable Town and/or State of Florida codes and/or ordinances. By signing below, I recognize Republic Services is by legal contract the sole authorized provider of garbage, recycling, yard waste, and commercial garbage and construction debris collection and disposal services with the city limits of the City. Contractors, homeowners and commercial businesses may contact Republic Services at 407-293-8000 to setup accounts for Commercial, Construction Roll Off, or other services needed. Rates are fixed by contract and are available at City Hall or from Republic Services. The City enforces the contract through its code enforcement office. Failure to comply will result in a stop work order.

LICENSE HOLDER SIGNATURE Roger Face LICENSE # CCC1326094

LICENSE HOLDER NAME Roger Face COMPANY NAME Self

Street Address 4310 Piermont Ct

City Orl State FL Zip Code 32817 Phone Number 407 416 0306

Email Address _____

Building Official: caj Date 10-9-14

Verified Contractor's Licenses & Insurance are on file caj Date 10-9-14

Zoning Fee \$ 30⁰⁰

Permit Fee \$ 80⁰⁰

Review Fee \$ n/a

3% Florida Surcharge \$ 4⁰⁰

Total Permit Fee \$ 114⁰⁰

NOTE: The Building Permit Number is required if the Roof Installation is associated with any construction or alteration where a Building Permit has been issued. Building Permit Number _____

25⁰⁰ = 1000⁰⁰
55⁰⁰ = 11000⁰⁰

Permit Number: _____
Folio/Parcel ID #: _____
Prepared by: _____

DOCH 20140513224 B: 10816 P: 9133
10/08/2014 02:40:21 PM Page 1 of 1
Rec Fee: \$10.00
Martha O. Haynie, Comptroller
Orange County, FL
MB - Ret To: ROGER FACEMIRE

Return to: Roger Facemire
4310 Piermont Ct
Orl FL 32817



NOTICE OF COMMENCEMENT

State of Florida, County of Orange

The undersigned hereby gives notice that improvement will be made to certain real property, and in accordance with Chapter 713, Florida Statutes, the following information is provided in this Notice of Commencement.

- Description of property** (legal description of the property, and street address if available)
1921 Hoffner Ave Belle Isle Fl
- General description of improvement**
Re Roof
- Owner information or Lessee information if the Lessee contracted for the improvement**
Name Deborah Hill
Address 1921 Hoffner Ave Belle Isle Fl
Interest in Property _____
Name and address of fee simple titleholder (if different from Owner listed above)
Name _____
Address _____
- Contractor**
Name Roger Facemire Telephone Number 4074160306
Address 4310 Piermont Ct Orl FL 32817
- Surety** (if applicable, a copy of the payment bond is attached)
Name NA Telephone Number _____
Address _____ Amount of Bond \$ _____
- Lender**
Name NA Telephone Number _____
Address _____
- Persons within the State of Florida designated by Owner upon whom notices or other documents may be served as provided by §713.13(1)(a)7, Florida Statutes.**
Name None Telephone Number _____
Address _____
- In addition to himself or herself, Owner designates the following to receive a copy of the Lienor's Notice as provided in §713.13(1)(b), Florida Statutes.**
Name None Telephone Number _____
Address _____
- Expiration date of notice of commencement** (the expiration date may not be before the completion of construction and final payment to the contractor, but will be 1 year from the date of recording unless a different date is specified) _____

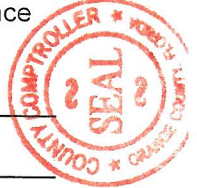

State of FLORIDA, County of ORANGE
I hereby certify that this is a true copy of the document as recorded in the Official Records.
MARTHA O. HAYNIE, COUNTY COMPTROLLER
By: mpf
Deputy Comptroller
10/8/14

WARNING TO OWNER: ANY PAYMENTS MADE BY THE OWNER AFTER THE EXPIRATION OF THE NOTICE OF COMMENCEMENT ARE CONSIDERED IMPROPER PAYMENTS UNDER CHAPTER 713, PART I, SECTION 713.13, FLORIDA STATUTES, AND CAN RESULT IN YOUR PAYING TWICE FOR IMPROVEMENTS TO YOUR PROPERTY. A NOTICE OF COMMENCEMENT MUST BE RECORDED AND POSTED ON THE JOB SITE BEFORE THE FIRST INSPECTION. IF YOU INTEND TO OBTAIN FINANCING, CONSULT WITH YOUR LENDER OR AN ATTORNEY BEFORE COMMENCING WORK OR RECORDING YOUR NOTICE OF COMMENCEMENT.

Deborah Hill

Signature of Owner or Lessee, or Owner's or Lessee's Authorized Officer/Director/Partner/Manager _____ Signatory's Title/Office _____

The foregoing instrument was acknowledged before me this 7 day of oct ²⁰¹⁴ by Deborah Hill
month/year name of person

as _____ for _____
Type of authority, e.g., officer, trustee, attorney in fact Name of party on behalf of whom instrument was executed

Gretchen LeGendre
Signature of Notary Public - State of Florida

Gretchen LeGendre
Print, type, or stamp commissioned name of Notary Public

Personally Known _____ OR Produced ID X
Type of ID Produced DL



GRETCHEN LEGENDRE
MY COMMISSION # FF 165525
EXPIRES: October 2, 2018
Bonded Thru Budget Notary Services



[DBPR HOME](#) |
 [ABOUT DBPR](#) |
 [DBPR DIVISIONS](#) |
 [CONTACT DBPR](#)

[BCIS Home](#) |
 [Log In](#) |
 [User Registration](#) |
 [Hot Topics](#) |
 [Submit Surcharge](#) |
 [Stats & Facts](#) |
 [Publications](#) |
 [FBC Staff](#) |
 [BCIS Site Map](#) |
 [Links](#) |
 [Search](#)



License efficiently. Regulate fairly.

OFFICE OF THE SECRETARY

[Product Approval Menu](#) >
 [Product or Application Search](#) >
 [Application List](#) >
 Application Detail

FL #	FL5444-R7								
Application Type	Revision								
Code Version	2010								
Application Status	Approved								
Comments									
Archived	<input type="checkbox"/>								
Product Manufacturer	CertainTeed Corporation-Roofing								
Address/Phone/Email	PO Box 1100 1400 Union Meeting Rd Blue Bell, PA 19422 (215) 274-2350 Steven.T.Lawrey@saint-gobain.com								
Authorized Signature	Steven Lawrey Steven.T.Lawrey@saint-gobain.com								
Technical Representative	Steven Lawrey								
Address/Phone/Email	1400 Union Meeting Road Blue Bell, PA 19422 (215) 274-2425 Steven.T.Lawrey@saint-gobain.com								
Quality Assurance Representative									
Address/Phone/Email									
Category	Roofing								
Subcategory	Asphalt Shingles								
Compliance Method	Evaluation Report from a Florida Registered Architect or a Licensed Florida Professional Engineer <input checked="" type="checkbox"/> Evaluation Report - Hardcopy Received								
Florida Engineer or Architect Name who developed the Evaluation Report	Robert Nieminen								
Florida License	PE-59166								
Quality Assurance Entity	UL LLC								
Quality Assurance Contract Expiration Date	07/03/2017								
Validated By	John W. Knezevich, PE <input checked="" type="checkbox"/> Validation Checklist - Hardcopy Received								
Certificate of Independence	FL5444 R7 COI 2014 04 COI Nieminen.pdf								
Referenced Standard and Year (of Standard)	<table border="0"> <thead> <tr> <th>Standard</th> <th>Year</th> </tr> </thead> <tbody> <tr> <td>ASTM D3161, Class F</td> <td>2006</td> </tr> <tr> <td>ASTM D3462</td> <td>2007</td> </tr> <tr> <td>ASTM D7158, Class H</td> <td>2007</td> </tr> </tbody> </table>	Standard	Year	ASTM D3161, Class F	2006	ASTM D3462	2007	ASTM D7158, Class H	2007
Standard	Year								
ASTM D3161, Class F	2006								
ASTM D3462	2007								
ASTM D7158, Class H	2007								
Equivalence of Product Standards Certified By									
Sections from the Code									

Product Approval Method Method 1 Option D

Date Submitted 04/29/2014
 Date Validated 05/05/2014
 Date Pending FBC Approval 05/07/2014
 Date Approved 06/23/2014

Summary of Products		
FL #	Model, Number or Name	Description
5444.1	CertainTeed Asphalt Roofing Shingles	3-tab, 4-tab, strip (no-cut-outs), laminated and architectural asphalt roof shingles
Limits of Use Approved for use in HVHZ: No Approved for use outside HVHZ: Yes Impact Resistant: N/A Design Pressure: N/A Other: Refer to ER Section 5 for Limits of Use		Installation Instructions FL5444 R7 II 2014 05 FINAL ER CERTAINTEED Asphalt Shingle FL5444-R7.pdf Verified By: Robert Nieminen, PE PE-59166 Created by Independent Third Party: Yes Evaluation Reports FL5444 R7 AE 2014 05 FINAL ER CERTAINTEED Asphalt Shingle FL5444-R7.pdf Created by Independent Third Party: Yes



Contact Us :: [1940 North Monroe Street, Tallahassee FL 32399](#) Phone: 850-487-1824

The State of Florida is an AA/EEO employer. [Copyright 2007-2013 State of Florida](#) :: [Privacy Statement](#) :: [Accessibility Statement](#) :: [Refund Statement](#)

Under Florida law, email addresses are public records. If you do not want your e-mail address released in response to a public-records request, do not send electronic mail to this entity. Instead, contact the office by phone or by traditional mail. If you have any questions, please contact 850.487.1395. *Pursuant to Section 455.275 (1), Florida Statutes, effective October 1, 2012, licensees licensed under Chapter 455, F.S. must provide the Department with an email address if they have one. The emails provided may be used for official communication with the licensee. However email addresses are public record. If you do not wish to supply a personal address, please provide the Department with an email address which can be made available to the public. To determine if you are a licensee under Chapter 455, F.S., please click [here](#).

Product Approval Accepts:





EXTERIOR RESEARCH & DESIGN, LLC.
 Certificate of Authorization #9503
 353 CHRISTIAN STREET, UNIT #13
 OXFORD, CT 06478
 PHONE: (203) 262-9245
 FAX: (203) 262-9243

EVALUATION REPORT

CertainTeed Corporation
1400 Union Meeting Road
Blue Bell, PA 19422

Evaluation Report 3532.09.05-R8
FL5444-R7
Date of Issuance: 09/22/2005
Revision 8: 05/05/2014

SCOPE:

This Evaluation Report is issued under Rule 61G20-3 and the applicable rules and regulations governing the use of construction materials in the State of Florida. The documentation submitted has been reviewed by Robert Nieminen, P.E. for use of the product under the Florida Building Code and Florida Building Code, Residential Volume. The products described herein have been designed to comply with the 2010 Florida Building Code.

DESCRIPTION: CertainTeed Asphalt Roofing Shingles.

LABELING: Labeling shall be in accordance with the requirements of the Accredited Quality Assurance Agency noted herein and FBC 1507.2.7.1.

CONTINUED COMPLIANCE: This Evaluation Report is valid until such time as the named product(s) changes, the referenced Quality Assurance documentation changes, or provisions of the Code that relate to the product change. Acceptance of this Evaluation Report by the named client constitutes agreement to notify Robert Nieminen, P.E. if the product changes or the referenced Quality Assurance documentation changes. Trinity|ERD requires a complete review of this Evaluation Report relative to updated Code requirements with each Code Cycle.

ADVERTISEMENT: The Evaluation Report number preceded by the words "Trinity|ERD Evaluated" may be displayed in advertising literature. If any portion of the Evaluation Report is displayed, then it shall be done in its entirety.

INSPECTION: Upon request, a copy of this entire Evaluation Report shall be provided to the user by the manufacturer or its distributors and shall be available for inspection at the job site at the request of the Building Official.

This Evaluation Report consists of pages 1 through 11.

Prepared by:

Robert J.M. Nieminen, P.E.
 Florida Registration No. 59166, Florida DCA ANE1983

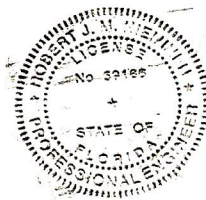

The facsimile seal appearing was authorized by Robert Nieminen, P.E. on 05/05/2014. This does not serve as an electronically signed document. Signed, sealed hardcopies have been transmitted to the Product Approval Administrator and to the named client.

CERTIFICATION OF INDEPENDENCE:

1. Trinity|ERD does not have, nor does it intend to acquire or will it acquire, a financial interest in any company manufacturing or distributing products it evaluates.
2. Trinity|ERD is not owned, operated or controlled by any company manufacturing or distributing products it evaluates.
3. Robert Nieminen, P.E. does not have nor will acquire, a financial interest in any company manufacturing or distributing products for which the evaluation reports are being issued.
4. Robert Nieminen, P.E. does not have, nor will acquire, a financial interest in any other entity involved in the approval process of the product.

ROOFING SYSTEMS EVALUATION:

1. SCOPE:

Product Category: Roofing
Sub-Category: Asphalt Shingles

Compliance Statement: CertainTeed Asphalt Roofing Shingles, as produced by CertainTeed Corporation, have demonstrated compliance with the following sections of the Florida Building Code and Florida Building Code, Residential Volume through testing in accordance with the following Standards. Compliance is subject to the Installation Requirements and Limitations / Conditions of Use set forth herein.

2. STANDARDS:

<u>Section</u>	<u>Property</u>	<u>Standard</u>	<u>Year</u>
1507.2.5, R905.2.4	Physical Properties	ASTM D3462	2007
1507.2.7.1, R905.2.6.1	Wind Resistance	ASTM D3161, Class F	2006
1507.2.7.1, R905.2.6.1	Wind Resistance	ASTM D7158, Class H	2007

3. REFERENCES:

<u>Entity</u>	<u>Examination</u>	<u>Reference</u>	<u>Date</u>
UL (TST 1740)	ASTM D3161	94NK9632	05/15/1998
UL (TST 1740)	ASTM D3161	99NK26506	11/23/1999
UL (TST 1740)	ASTM D3161	03CA12702	05/27/2003
UL (TST 1740)	ASTM D3161	03CA12702	06/16/2003
UL (TST 1740)	ASTM D3161	03NK29847	10/03/2003
UL (TST 1740)	ASTM D3161	04CA11329	05/24/2004
UL (TST 1740)	ASTM D3161	04CA32986	12/03/2004
UL (TST 1740)	ASTM D3161	05NK07049	04/15/2005
UL (TST 1740)	ASTM D3161	05NK16778	05/12/2005
UL (TST 1740)	ASTM D3161	05CA16778	05/12/2005
UL (TST 1740)	ASTM D3161	05NK14836	05/22/2005
UL (TST 1740)	ASTM D3161	05NK22800	06/22/2005
UL (TST 1740)	ASTM D3462	R684	09/21/2005
UL (TST 1740)	ASTM D7158	05NK08037	06/28/2006
UL (TST 1740)	ASTM D3161 & D3462	09CA28873	07/23/2009
UL (TST 1740)	ASTM D3462	10CA41303	10/07/2010
UL (TST 1740)	ASTM D3161	10CA41303	10/08/2010
UL (TST 1740)	ASTM D7158	10CA41303	10/27/2010
UL (TST 1740)	ASTM D3161 & D3462	10CA44960	11/11/2010
UL LLC (TST 9628)	ASTM D3161, D3462 & D7158	13CA32897	11/21/2013
UL LLC (TST 9628)	ASTM D3161, D3462	TFWZ.R684	04/22/2014
UL LLC (TST 9628)	ASTM D7158	TGAH.R684	04/22/2014
UL LLC (QUA 9625)	Quality Control	Service Confirmation	Exp. 02/13/2016

4. PRODUCT DESCRIPTION:

- 4.1 CT20™, XT™ 25, XT™ 30 and XT™ 30 IR are fiberglass reinforced, 3-tab asphalt roof shingles.
- 4.2 Carriage House Shangle®, Centennial Slate™, Grand Manor Shangle®, Landmark™, Landmark™ IR, Landmark™ Pro, Landmark™ Premium, Landmark™ TL, Landmark™ Solaris and Landmark™ Solaris IR are fiberglass reinforced, laminated asphalt roof shingles.
- 4.3 Presidential Shake™, Presidential Shake™ IR and Presidential Shake TL™ are fiberglass reinforced, architectural asphalt roof shingles.
- 4.4 Hatteras™, Highland Slate™ and Highland Slate™ IR are fiberglass reinforced, 4-tab asphalt roof shingles.
- 4.5 Patriot™ is a fiberglass reinforced asphalt roof strip-shingle (with no cut-outs) providing a laminated appearance through an intermittent shadow line with contrasting blend drops for color definition.
- 4.6 Presidential Accessory, Accessory for Hatteras, Shangle Ridge™, Shadow Ridge™, Cedar Crest™ and Cedar Crest™ IR are fiberglass reinforced accessory shingles for hip and ridge installation.
- 4.7 Any of the above listed shingles may be produced in AR (algae resistant) versions.

5. LIMITATIONS:

- 5.1 This Evaluation Report is not for use in the HVHZ
- 5.2 Fire Classification is not part of this Evaluation Report; refer to current Approved Roofing Materials Directory for fire ratings of this product.
- 5.3 Wind Classification:
 - 5.3.1 All shingles noted herein are Classified in accordance with FBC Tables 1507.2.7.1 and R905.2.6.1 to ASTM D3161, Class F and/or ASTM D7158, Class H, indicating the shingles are acceptable for us in all wind zones up to $V_{asd} = 150$ mph ($V_{ult} = 194$ mph). Refer to Section 6 for installation requirements to meet this wind rating.
 - 5.3.2 Presidential Accessory, Accessory for Hatteras, Shangle Ridge, Shadow Ridge and Cedar Crest hip & ridge shingles have been evaluated in accordance with ASTM D3161, Class F when BASF Sonolastic NP 1 adhesive or Henkel PL® Polyurethane Roof & Flashing Sealant, applied as specified in manufacturer's application instructions, indicating the shingles are acceptable for us in all wind zones up to $V_{asd} = 150$ mph ($V_{ult} = 194$ mph).
 - 5.3.3 Classification by ASTM D7158 applies to exposure category B or C and a building height of 60 feet or less. Calculations by a qualified design professional are required for conditions outside these limitations. Contact the shingle manufacturer for data specific to each shingle.
 - 5.3.3.1 Analysis in accordance with ASTM D7158 indicates the measured uplift resistance (R_T) for the CertainTeed asphalt roofing shingles listed in Section 4.1 through 4.5 exceeds the calculated uplift force (F_T) at a maximum design wind speed of $V_{asd} = 150$ mph ($V_{ult} = 194$ mph) for residential buildings located in Exposure D conditions with no topographical variations (flat terrain) having a mean roof height less than or equal to 60 feet.

The shingles are permissible under Code for installation in these conditions using the installation procedures detailed in this Evaluation Report and CertainTeed minimum requirements, subject to minimum codified fastening requirements established within any local jurisdiction, which shall take precedence.
- 5.4 All products in the roof assembly shall have quality assurance audits in accordance with the Florida Building Code and F.A.C. Rule 61G20-3.

6. INSTALLATION:

- 6.1 Roof deck, slope, underlayment and fasteners shall comply with FBC 1507.2 / R905.2 and the shingle manufacturer's minimum requirements.
- 6.1.1 Underlayment shall be acceptable to CertainTeed Corporation and shall hold current Florida Statewide Product Approval, or be Locally Approved per Rule 61G20-3, per FBC Sections 1507.2.3, 1507.2.4 or R905.2.3.
- 6.2 Installation of asphalt shingles shall comply with the manufacturer's current published instructions, using minimum four (4) nails per shingle in accordance with FBC 1507.2.7 or Section R905.2.6 and the minimum requirements herein.
- 6.2.1 Fasteners shall be in accordance with manufacturer's published requirements, but not less than FBC 1507.2.6 or R905.2.5. Staples are not permitted.
- 6.2.2 Where the roof slope exceeds 21 units vertical in 12 units horizontal, use the "Steep Slope" directions.
- 6.3 CertainTeed asphalt shingles are acceptable for use in reroof (tear-off) or recover applications, subject to the limitations set forth in FBC Section 1510 and CertainTeed published installation instructions.

6.3.1 **CT20™, XT™ 25, XT™ 30, XT™ 30 IR:**

LOW AND STANDARD SLOPE

ENGLISH

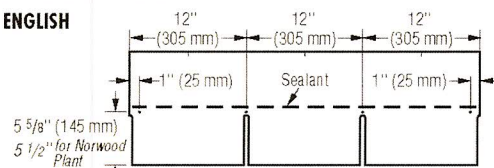

METRIC

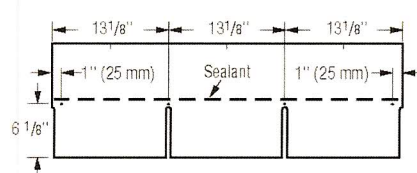
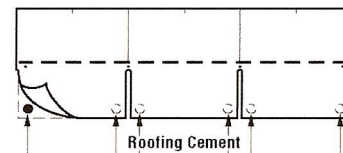

Figure 11-3: Use **four** nails for every full shingle.

STEEP SLOPE

Use **four** nails and six spots of asphalt roofing cement* for every full shingle (Figure 11-4). Asphalt roofing cement meeting ASTM D4586 Type II is suggested.



Apply 1" (25 mm) spots of asphalt roofing cement under each tab corner.

Figure 11-4: Use **four** nails and six spots of asphalt cement on steep slopes.

***CAUTION:** Excessive use of roofing cement can cause shingles to blister.

6.3.1.1 Hip & Ridge: Cut Shingles

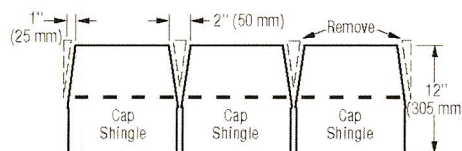

Figure 11-24: Cut tabs, then trim back to make cap shingles (English dimensions shown).

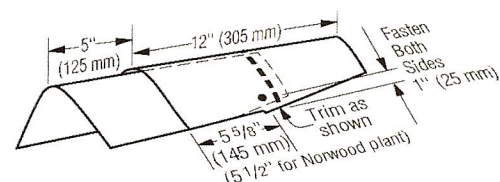

Figure 11-25: Installation of caps along the hips and ridges.

Note: For ASTM D3161 - Class F, use BASF Sonolastic NP 1 adhesive or Henkel PL® Polyurethane Roof & Flashing Sealant, in accordance with manufacturer's instructions.

6.3.2 **Carriage House Shingle®, Centennial Slate™ and Grand Manor Shingle®:**

LOW AND STANDARD SLOPE

Use **five** nails for every full Shingle.

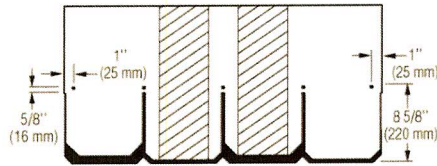

Figure 17-4: Use five nails for every full Grand Manor Shingle, Carriage House Shingle, or Centennial Slate.

STEEP SLOPE

Use **seven** nails and three spots of asphalt roofing cement for every full Grand Manor Shingle. Use **five** nails and three spots of asphalt roofing cement for every full Carriage House Shingle and Centennial Slate. Apply asphalt roofing cement 1" (25 mm) from edge of shingle (Figure 17-5). Asphalt roofing cement meeting ASTM D4586 Type II is suggested.

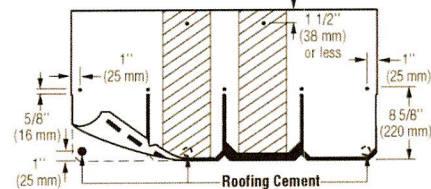

Figure 17-5: When installing Grand Manor Shingles on steep slopes, use **seven** nails and three spots of asphalt roofing cement.

6.3.2.1 Hip & Ridge: Shingle® Ridge

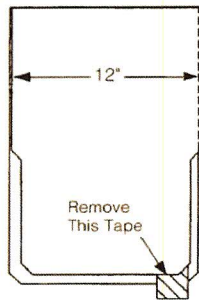

Figure 17-18: Shingle® Ridge.

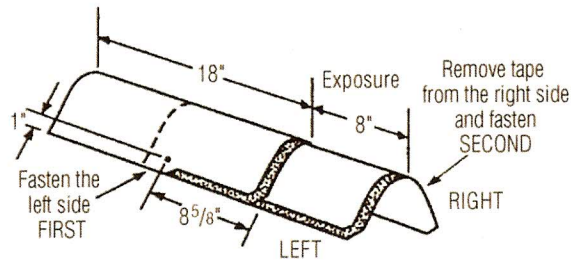

Figure 17-19: Installation of Shingle® Ridge shingles on hips and ridges.

Note: For ASTM D3161 - Class F, use BASF Sonolastic NP 1 adhesive or Henkel PL® Polyurethane Roof & Flashing Sealant in accordance with manufacturer's instructions.

6.3.3 **Landmark™, Landmark™ IR, Landmark™ Pro (formerly Landmark™ Plus), Landmark™ Premium, Landmark™ TL, Landmark™ Solaris, Landmark™ Solaris IR:**

LOW AND STANDARD SLOPE

METRIC DIMENSIONS

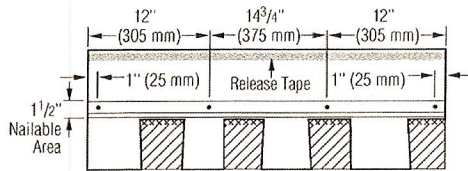

LANDMARK TL

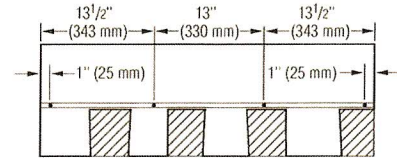
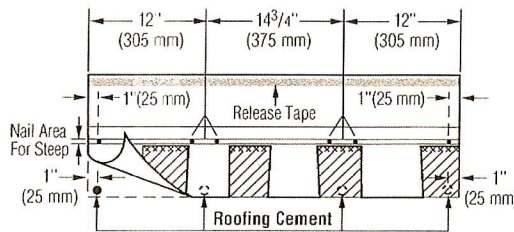

Figure 13-4: Use four nails for every full shingle.

STEEP SLOPE

Use six nails and four spots of asphalt roofing cement for every full laminated shingle. See below. Asphalt roofing cement should meet ASTM D4586 Type II. Apply 1" spots of asphalt roofing cement under each corner and at about 12" to 13" in from each edge.

METRIC DIMENSIONS



LANDMARK TL

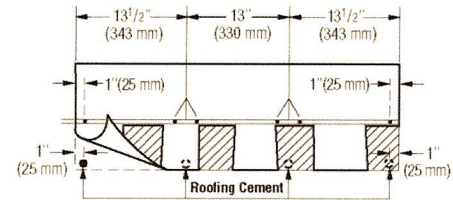

Figure 13-5: Use six nails and four spots of asphalt roofing cement on steep slopes.

6.3.3.1 Hip & Ridge, Option 1: Shadow Ridge™

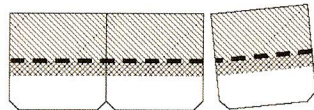
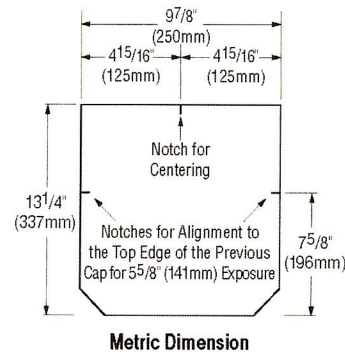
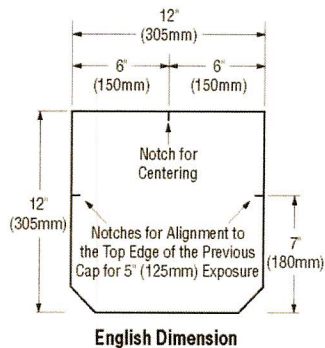

Figure 13-16: Shadow Ridge accessory shingles detach easily from three-piece units to make 72 individual cap pieces.



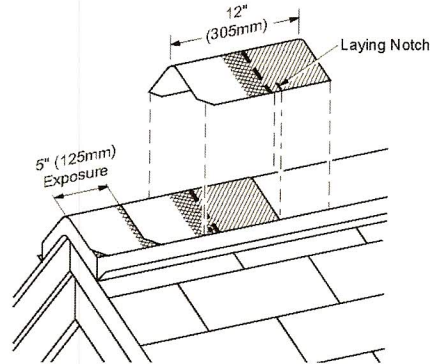
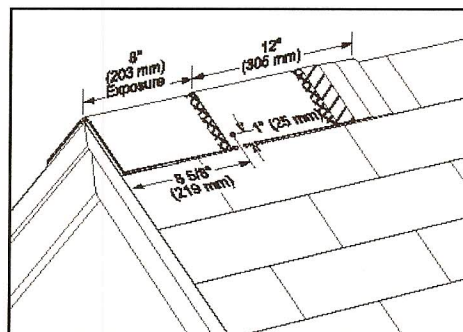

Figure 13-20: Use laying notches to center shingles on hips and ridges, and to locate the correct exposure.

Note: For ASTM D3161 - Class F, use BASF Sonolastic NP 1 adhesive or Henkel PL® Polyurethane Roof & Flashing Sealant in accordance with manufacturer's instructions.

6.3.3.2 Hip & Ridge, Option 2: Cedar Crest™, Cedar Crest™ IR

Use two fasteners per shingle. For the starter shingle, place fastener 1-inch from each side edge and about 2-inch up from the starter shingle's exposed butt edge. For each full Cedar Crest shingle, place fasteners 8-5/8-inch up from its exposed butt edge and 1-inch from each side edge.



Note: For ASTM D3161 - Class F, use BASF Sonolastic NP 1 adhesive or Henkel PL® Polyurethane Roof & Flashing Sealant to hand-seal Cedar Crest shingles. Apply NP 1 or PL adhesive from the middle of the shingle's raised overlay on the top piece and extending approximately 4-inch along the sides of the headlap along a line 3/4 to 1-inch from each side of the shingle's headlap. Immediately align and apply the overlying shingle, gently pressing tab sides into the adhesive, and install nails. To secure the other side, apply a 1-inch diameter spot of NP 1 or PL adhesive between the shingle layers.

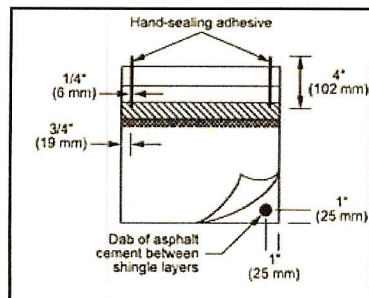

6.3.4 **Presidential Shake™, Presidential Shake™ IR, Presidential Shake TL™:**

LOW AND STANDARD SLOPE:

For low and standard slopes, use five nails for each full Presidential shingle as shown below.

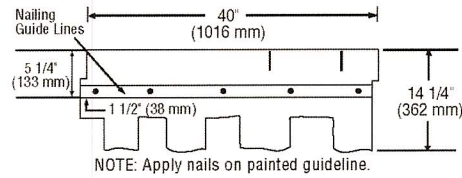

Figure 16-6: Fastening Presidential and Presidential TL Shake shingles on low and standard slopes.

STEEP SLOPE:

For steep slopes, use nine nails for each full Presidential shingle and apply 1" diameter spots of asphalt roofing cement under each shingle tab. After applying 5 nails in between the nailing guide lines, apply 4 nails 1" above tab cutouts making certain tabs of overlying shingle cover nails.

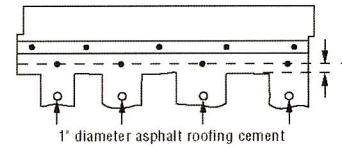

Figure 16-7: Fastening Presidential and Presidential TL Shake shingles on steep slopes.

6.3.4.1 Hip & Ridge, Option 1: Presidential Accessory

PRESIDENTIAL ACCESSORY

Presidential accessory shingles can be used for covering hips and ridges. Apply shingles up to the ridge (expose no more than 7" from the bottom edge of the "tooth." Fasten each accessory with two fasteners. The fasteners must be 1 3/4" long or longer, so they penetrate either 3/4" into the deck or completely through the deck. Presidential accessory comes in two different sizes: Accessory produced in Birmingham, AL is 12" x 12"; Portland, OR produces 9 7/8" x 13 1/4" accessory.

Note: For ASTM D3161 - Class F, use BASF Sonolastic NP 1 adhesive or Henkel PL® Polyurethane Roof & Flashing Sealant in accordance with manufacturer's instructions.

6.3.4.2 Hip & Ridge, Option 2: Refer to instructions herein for Cedar Crest™, Cedar Crest™ IR hip and ridge shingles.

6.3.5 **Hatteras™:**

LOW, STANDARD AND STEEP SLOPE:

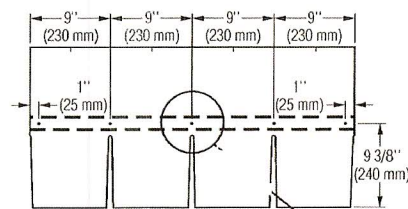

Figure 15-3: Fastening Hatteras Shingles on Low and Standard Slopes

For low and standard slopes, use five nails for each full Hatteras shingle as shown above.

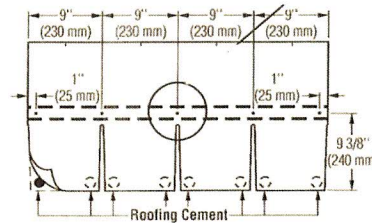

Figure 15-4: Fastening Hatteras Shingles on Steep Slopes

For steep slopes, use five nails and eight spots of asphalt roofing cement for each full Hatteras shingle as shown above. Apply 1" (25mm) diameter spots of roofing cement (ASTM D 4586 Type II suggested) under each tab corner. Press shingle into place; do not expose cement.

CAUTION: Too much roofing cement can cause shingles to blister.

6.3.5.1 Hip & Ridge, Option 1: Accessory for Hatteras

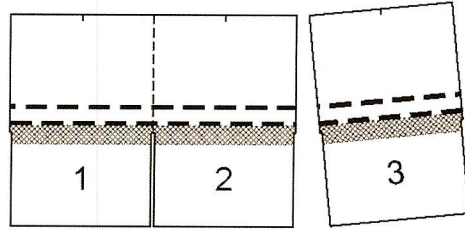
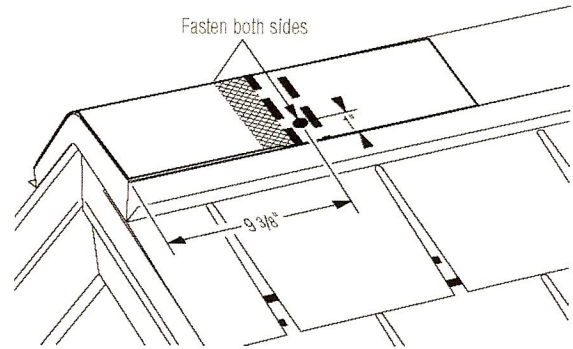

Figure 15-14: 18 three-piece units separate to make 54 Hatteras Accessory shingles.



Note: For ASTM D3161 - Class F, use BASF Sonolastic NP 1 adhesive or Henkel PL® Polyurethane Roof & Flashing Sealant in accordance with manufacturer's instructions.

6.3.5.2 Hip & Ridge, Option 2: Cut Hatteras Shingles

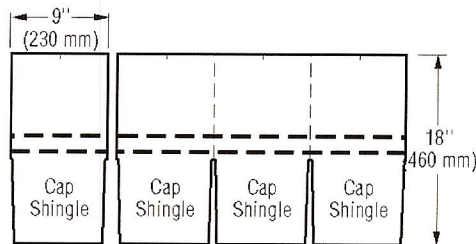

Figure 15-20: Cut Hatteras shingles to make cover cap.

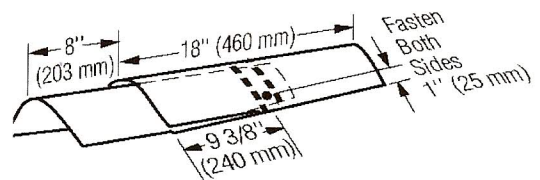

Figure 15-21: Installation of caps along hips and ridges.

Note: For ASTM D3161 - Class F, use BASF Sonolastic NP 1 adhesive or Henkel PL® Polyurethane Roof & Flashing Sealant in accordance with manufacturer's instructions.

6.3.6 **Highland Slate™, Highland Slate™ IR:**

LOW AND STANDARD SLOPE:

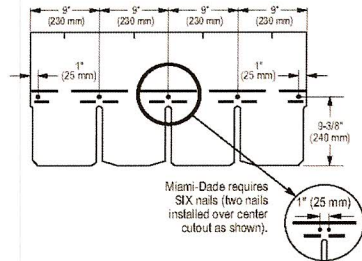

Figure 11-3: Use FIVE nails for every Highland Slate shingle.

STEEP SLOPE:

Use FIVE nails and EIGHT spots of asphalt roofing cement* for each full Highland Slate shingle. For Miami-Dade, SIX nails are required. Apply 1" diameter spots of asphalt roofing cement under each tab corner. Asphalt roofing cement meeting ASTM D4586 Type II is suggested.

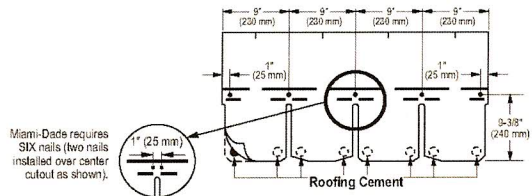

Figure 11-3A: Use FIVE nails and eight spots of asphalt roofing cement under each tab corner.

*CAUTION: Excessive use of roofing cement can cause shingles to blister.

6.3.6.1 Hip & Ridge, Option 1: Refer to instructions herein for Cedar Crest™, Cedar Crest™ IR or Shangle Ridge™ hip and ridge shingles.

6.3.7 **Patriot™:**

LOW AND STANDARD SLOPE

Use FOUR nails for every full shingle located as shown below.

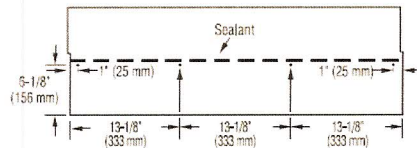

STEEP SLOPE

Use FOUR nails and four spots of asphalt roofing cement for every full shingle as shown below. Asphalt roofing cement meeting ASTM D4586 Type II is suggested. Apply 1" (25 mm) spots of asphalt roofing cement as shown.

CAUTION: Excessive use of roofing cement can cause shingles to blister.

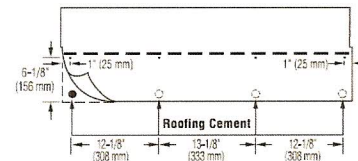

Hip & Ridge: Refer to instructions herein for Cedar Crest™, Cedar Crest™ IR, Shadow Ridge™ or Shangle Ridge™ hip and ridge shingles.

7. LABELING:

- 7.1 Each unit shall bear a permanent label with the manufacturer's name, logo, city, state and logo of the Accredited Quality Assurance Agency noted herein.
- 7.2 Asphalt shingle wrappers shall indicate compliance with one of the required classifications detailed in FBC Table 1507.2.7.1 / R905.2.6.1.

8. BUILDING PERMIT REQUIREMENTS:

As required by the Building Official or Authority Having Jurisdiction in order to properly evaluate the installation of this product.

9. MANUFACTURING PLANTS:

Contact the named QA entity for information on which plants produce products covered by Florida Rule 61G20-3 QA requirements.

10. QUALITY ASSURANCE ENTITY:

UL LLC – QUA9625; (414) 248-6409; karen.buchmann@us.ul.com

- END OF EVALUATION REPORT -

CERTIFICATE OF LIABILITY INSURANCE

Date
10/9/2014

Producer: Lion Insurance Company
2739 U.S. Highway 19 N.
Holiday, FL 34691
(727) 938-5562

This Certificate is issued as a matter of information only and confers no rights upon the Certificate Holder. This Certificate does not amend, extend or alter the coverage afforded by the policies below.

Insured: South East Personnel Leasing, Inc. & Subsidiaries
2739 U.S. Highway 19 N.
Holiday, FL 34691

Insurers Affording Coverage		NAIC #
Insurer A:	Lion Insurance Company	11075
Insurer B:		
Insurer C:		
Insurer D:		
Insurer E:		

Coverages

The policies of insurance listed below have been issued to the insured named above for the policy period indicated. Notwithstanding any requirement, term or condition of any contract or other document with respect to which this certificate may be issued or may pertain, the insurance afforded by the policies described herein is subject to all the terms, exclusions, and conditions of such policies. Aggregate limits shown may have been reduced by paid claims.

INSR LTR	ADDL INSRD	Type of Insurance	Policy Number	Policy Effective Date (MM/DD/YY)	Policy Expiration Date (MM/DD/YY)	Limits												
		GENERAL LIABILITY <input type="checkbox"/> Commercial General Liability <input type="checkbox"/> Claims Made <input type="checkbox"/> Occur <hr/> General aggregate limit applies per: <input type="checkbox"/> Policy <input type="checkbox"/> Project <input type="checkbox"/> LOC				Each Occurrence \$ Damage to rented premises (EA occurrence) \$ Med Exp \$ Personal Adv Injury \$ General Aggregate \$ Products - Comp/Op Agg \$												
		AUTOMOBILE LIABILITY <input type="checkbox"/> Any Auto <input type="checkbox"/> All Owned Autos <input type="checkbox"/> Scheduled Autos <input type="checkbox"/> Hired Autos <input type="checkbox"/> Non-Owned Autos				Combined Single Limit (EA Accident) \$ Bodily Injury (Per Person) \$ Bodily Injury (Per Accident) \$ Property Damage (Per Accident) \$												
		EXCESS/UMBRELLA LIABILITY <input type="checkbox"/> Occur <input type="checkbox"/> Claims Made Deductible				Each Occurrence Aggregate												
A		Workers Compensation and Employers' Liability Any proprietor/partner/executive officer/member excluded? NO If Yes, describe under special provisions below.	WC 71949	01/01/2014	01/01/2015	<table border="1" style="width: 100%; border-collapse: collapse;"> <tr> <td style="text-align: center;"><input checked="" type="checkbox"/> WC Statutory Limits</td> <td style="text-align: center;"><input type="checkbox"/> OTH-ER</td> <td></td> </tr> <tr> <td colspan="2">E.L. Each Accident</td> <td style="text-align: right;">\$1,000,000</td> </tr> <tr> <td colspan="2">E.L. Disease - Ea Employee</td> <td style="text-align: right;">\$1,000,000</td> </tr> <tr> <td colspan="2">E.L. Disease - Policy Limits</td> <td style="text-align: right;">\$1,000,000</td> </tr> </table>	<input checked="" type="checkbox"/> WC Statutory Limits	<input type="checkbox"/> OTH-ER		E.L. Each Accident		\$1,000,000	E.L. Disease - Ea Employee		\$1,000,000	E.L. Disease - Policy Limits		\$1,000,000
<input checked="" type="checkbox"/> WC Statutory Limits	<input type="checkbox"/> OTH-ER																	
E.L. Each Accident		\$1,000,000																
E.L. Disease - Ea Employee		\$1,000,000																
E.L. Disease - Policy Limits		\$1,000,000																

Other

Lion Insurance Company is A.M. Best Company rated A- (Excellent). AMB # 12616

Descriptions of Operations/Locations/Vehicles/Exclusions added by Endorsement/Special Provisions:

Client ID: 36-66-127

Coverage only applies to active employee(s) of South East Personnel Leasing, Inc. & Subsidiaries that are leased to the following "Client Company":

Roger Facemire

Coverage only applies to injuries incurred by South East Personnel Leasing, Inc. & Subsidiaries active employee(s), while working in: FL.

Coverage does not apply to statutory employee(s) or independent contractor(s) of the Client Company or any other entity.

A list of the active employee(s) leased to the Client Company can be obtained by faxing a request to (727) 937-2138 or by calling (727) 938-5562.

Project Name:

FAX: 407-648-0781, 407-581-0313 ISSUE 10-08-14 (AF) / REISSUE 10-09-14 (TD)

Begin Date 12/11/2013

CERTIFICATE HOLDER	CANCELLATION
CITY OF BELLE ISLE 1600 NELA AVE. BELLE ISLE, FL 32809	Should any of the above described policies be cancelled before the expiration date thereof, the issuing insurer will endeavor to mail 30 days written notice to the certificate holder named to the left, but failure to do so shall impose no obligation or liability of any kind upon the insurer, its agents or representatives.

John A. Jones

BOB McKEE
LAKE COUNTY TAX COLLECTOR

EMPLOYEES 10

TYPE OF BUSINESS CONTRACTING

BUSINESS ROGER W FACEMIRE
14418 GRAND HWY

ROGER W FACEMIRE
4310 PIERMONT CT
ORLANDO, FL 32817

2014 / 2015
LAKE COUNTY BUSINESS TAX RECEIPT
STATE OF FLORIDA

ACCT NO. 421
RECEIPT NO. 2270000017
EXPIRES SEPTEMBER 30, 2015

ORIGINAL TAX 30.00
PENALTY 0.00
TRANSFER FEE 0.00
AMOUNT PAID 30.00
TOTAL DUE \$0.00

Receipt #2014-0050049
Paid 09/09/2014 30.00

RICK SCOTT, GOVERNOR

KEN LAWSON, SECRETARY

STATE OF FLORIDA
DEPARTMENT OF BUSINESS AND PROFESSIONAL REGULATION
CONSTRUCTION INDUSTRY LICENSING BOARD

LICENSE NUMBER

CCC1326094

The ROOFING CONTRACTOR
Named below IS CERTIFIED
Under the provisions of Chapter 489 FS.
Expiration date: AUG 31, 2016

FACEMIRE, ROGER WAYNE
INDIVIDUAL
4310 PIERMONT CT
ORLANDO FL 32817



ISSUED: 08/24/2014

DISPLAY AS REQUIRED BY LAW

SEQ # L1408240003070