



# City of Belle Isle

Universal Engineering Sciences 3532 Maggie Blvd., Orlando, FL 32811  
 Tel 407-581-8161 \* Fax 407-581-0313 \* [www.universalengineering.com](http://www.universalengineering.com)

## PERMIT CARD – PLEASE POST AT JOB SITE

THIS DOCUMENT BECOMES YOUR PERMIT WHEN PROPERLY VALIDATED

Per FBC 105.3.3: An enforcing authority may not issue a building permit for any building construction, erection, alteration, modification, repair or addition unless the permit either includes on its face or there is attached to the permit the following statement: "NOTICE: In addition to the requirements of this permit, there may be additional restrictions applicable to this property that may be found in the public records of this county, and there may be additional permits required from other governmental entities such as water management districts, state agencies, or federal agencies." The issuance of this permit does not grant permission to violate any applicable City, Orange County, State of Florida and/or Federal codes and/or ordinances. Separate permits are required for Signs, Roofing, Electrical, Gas, Plumbing and Mechanical services. This permit becomes VOID if the work authorized is not commenced within 6 months, or is suspended or abandoned for a period of 6 months after commencement. **WORK SHALL BE CONSIDERED SUSPENDED IF AN APPROVED INSPECTION HAS NOT BEEN MADE WITHIN A 6 MONTH PERIOD.** PERMISSION IS GRANTED TO DO THE FOLLOWING WORK ACCORDING TO THE CONDITIONS HEREON AND THE APPROVED PLANS AND SPECIFICATIONS, SUBJECT TO COMPLIANCE WITH THE ORDINANCES OF THE CITY OF BELLE ISLE, FLORIDA.

<p><b>Scope of Work:</b> REROOF: 41sq, asphalt shingles</p> <p><b>Comments:</b> None</p> <p><b>Project Information</b>        Address: 5012 Gran Lac Avenue, Belle Isle, FL 32812        Parcel ID: 18-23-30-4386-03-880        Property Owner: Morris, Hedy        Phone Number: None        *****        Company Name: Universal Roofing Group, Inc.        Contractor Name: Mellick, Ken        License Number: CCC057165        Address: 5655 Carder Road, Orlando, FL 32810        Phone Number: 407-295-7403</p>	<p style="text-align: right;"><b>Permit Number: 2014-06-022</b></p> <p style="text-align: right;"><b>Date of Application: 06/11/2014</b>  <b>Date Permit Issued: 06/12/2014</b></p> <p><b>WARNING TO OWNER:</b> "YOUR FAILURE TO RECORD A NOTICE OF COMMENCEMENT MAY RESULT IN YOU PAYING TWICE FOR IMPROVEMENTS TO YOUR PROPERTY. IF YOU INTEND TO OBTAIN FINANCING, CONSULT WITH YOUR LENDER OR AN ATTORNEY BEFORE RECORDING YOUR NOTICE OF COMMENCEMENT." ON THE JOB INSPECTION(S) MUST BE MADE BEFORE PROCEEDING WITH SUBSEQUENT WORK. THIS CARD MUST BE DISPLAYED OUTSIDE AND BE PROTECTED FROM THE WEATHER WHILE BEING VISIBLE FROM THE STREET UNTIL THE FINAL INSPECTIONS HAVE BEEN APPROVED.</p>
--	--

### BUILDING FEATURES

<p><b>IMPACT FEES</b></p> <p>School \$        Traffic \$</p> <p><b>ZONING FEES</b></p> <p>Zoning Fee \$30.00</p> <p><b>UNIVERSAL ENG - BUILDING FEES</b></p> <p>Cert of Occ \$        Demo \$        Building \$        Fence \$        Driveway \$        Shed \$        Window(s) \$        Door(s) \$        PrePower \$        Electrical \$        Temp Pole \$        Plumbing \$        Mechanical \$        Gas \$        Roofing \$85.00        Boat Dock \$        Screen Encl \$        Swimming Pool \$        Sign \$</p> <p><b>SURCHARGE FEES</b></p> <p>Surcharge Fee \$2.00        Surcharge Fee \$2.00</p> <p style="text-align: center;"><b><u>TOTAL FEES \$119.00</u></b></p> <p><b>Date Paid</b> <u>6-12-14</u></p> <p><b>CC or Check #</b> <u>14340</u></p> <p><b>Amount Paid</b> <u>119.00</u></p> <p>The person accepting this permit shall conform to the terms of the application on file and construction shall conform to the requirements of the Florida Building Code (FS 553).</p>	<p style="text-align: center;"><b>BUILDING INSPECTOR USE ONLY</b></p> <p>IF APPLICABLE:        Have Zoning Approval Conditions Been Met? YES NO    Have Stormwater Approval Conditions Been Met? YES NO    Silt fencing in place? YES NO    Turbidity Barrier in place? YES NO</p> <p><input type="checkbox"/> <b>BUILDING</b></p> <p>1<sup>st</sup> _____ (Footing/Foundation)        Survey specific foundation plan must be onsite before slab pour. Approved Plan on Site? ____</p> <p>2<sup>nd</sup> _____ (Slab)</p> <p>3<sup>rd</sup> _____ (Lintel)(Wall Reinforcing on Masonry Building)</p> <p>4<sup>th</sup> _____ (Exterior Framing)(Roof/Wall Sheathing)</p> <p>5<sup>th</sup> _____ (Framing) (To be made after Plumbing/ Mechanical/ Electrical Rough-Ins &amp; Windows/Doors Installed)</p> <p>6<sup>th</sup> _____ (Insulation to be Made After Roof Installed)</p> <p>7<sup>th</sup> _____ (Drywall)</p> <p>8<sup>th</sup> _____ (Sidewalk/Driveway)</p> <p>9<sup>th</sup> _____ (Other)</p> <p>10<sup>th</sup> _____ (Final – After MEP and Other Applicable Finals)</p> <p><input type="checkbox"/> <b>ROOFING</b></p> <p>1<sup>ST</sup> ROOFING Deck Nailing/Dry-in/Flashing _____</p> <p>2<sup>nd</sup> ROOFING Covering In-Progress _____</p> <p>3<sup>rd</sup> ROOFING Covering Final _____</p> <p><input type="checkbox"/> <b>PLUMBING</b> (Pool-Piping, Solar, Irrigation, Water Treatment Equip, Etc...)</p> <p><input type="checkbox"/></p> <p>1<sup>ST</sup> _____ (Underground)    2<sup>nd</sup> _____ (Sewer)</p> <p>3<sup>rd</sup> _____ (Rough-In/Tub Set)    4<sup>th</sup> _____ (Final)</p> <p><b>CHECK APPROPRIATE BOX</b></p> <p><input type="checkbox"/> GAS ___ Natural ___ LP    <input type="checkbox"/> MECHANICAL    <input type="checkbox"/> ELECTRICAL    <input type="checkbox"/> LOW VOLTAGE</p> <p>1<sup>st</sup> _____ (Rough-In)    2<sup>nd</sup> _____ (Final)</p>
--	--

Inspection requests are to be emailed to [BidScheduling@UniversalEngineering.com](mailto:BidScheduling@UniversalEngineering.com); a confirmation email will be sent back to you upon scheduling. **Next-Day Inspection requests must be made by 1pm.** Please include the following in your request: Permit #, project address, type of inspection, date of the requested inspection, a contact name & a contact phone number. AM or PM may be requested but cannot be guaranteed.



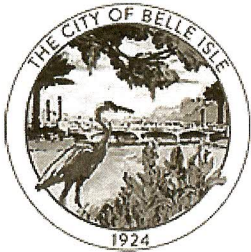

# City of Belle Isle

Universal Engineering Sciences 3532 Maggie Blvd., Orlando, FL 32811  
Tel 407-581-8161 \* Fax 407-581-0313 \* [www.universalengineering.com](http://www.universalengineering.com)

**received**  
6-11-14

## APPLICATION FOR ROOFING PERMIT

**WARNING TO OWNER:** YOUR FAILURE TO RECORD A NOTICE OF COMMENCEMENT MAY RESULT IN YOUR PAYING TWICE FOR IMPROVEMENTS TO YOUR PROPERTY. A NOTICE OF COMMENCEMENT MUST BE RECORDED AND POSTED ON THE JOB SITE BEFORE THE FIRST INSPECTION. IF YOU INTEND TO OBTAIN FINANCING, CONSULT WITH YOUR LENDER OR AN ATTORNEY BEFORE RECORDING YOUR NOTICE OF COMMENCEMENT.

DATE OF APPLICATION: \_\_\_\_\_

ROOF PERMIT NUMBER 2014-06-022

PLEASE PRINT. The undersigned hereby applies for a permit to make installations as indicated below:

Project Address 5012 Gran Lac Ave., Belle Isle, FL # 32809 32812

Property Owner Hedy Morris Phone \_\_\_\_\_

Property Owner's Mailing Address 5012 Gran Lac Ave City Belle Isle

State FL Zip Code 32812 Parcel Id Number: 14-23-30-4386-03-880

REQUIRED! To obtain this information, please visit <http://www.ocpaf.org/Searches/ParcelSearch.aspx>

Class of Building: Old  New  Type of Building: Residential  Commercial  Other

Type of Work: New Roof  ReRoof

- REQUIRED! Florida Product Approval Screen Printout from [www.floridabuilding.org](http://www.floridabuilding.org) showing the Code Version
- REQUIRED! Florida Product Approval Installation Instructions from [www.floridabuilding.org](http://www.floridabuilding.org) (not the manufacturer instructions)
- REQUIRED! Copies of your General Liability & Worker's Comp Insurance Certificate & State and Local Licenses

Please indicate the nature of work by completing the information below:

Roof Square Footage: 41 sq. Number of Stories: 2 Job Valuation: \$ 12,300.00

Type: Asphalt Shingles  Metal  Modified Bitumen  Other: \_\_\_\_\_

I hereby certify that the above is true and correct to the best of my knowledge and make Application for Permit as outlined above, and if same is granted I agree to conform to all Florida Building Code Regulations and City Ordinances regulating same and in accordance with plans submitted. The issuance of this permit does not grant permission to violate any applicable Town and/or State of Florida codes and/or ordinances. By signing below, I recognize Republic Services is by legal contract the sole authorized provider of garbage, recycling, yard waste, and commercial garbage and construction debris collection and disposal services with the city limits of the City. Contractors, homeowners and commercial businesses may contact Republic Services at 407-293-8000 to setup accounts for Commercial, Construction Roll Off, or other services needed. Rates are fixed by contract and are available at City Hall or from Republic Services. The City enforces the contract through its code enforcement office. Failure to comply will result in a stop work order.

LICENSE HOLDER SIGNATURE Ken Mellie LICENSE # CC057165  
LICENSE HOLDER NAME KEN MELLIE COMPANY NAME Universal Roofing Contract  
Street Address 5655 Carder Rd.  
City Orlando State FL Zip Code 32810 Phone Number 407-295-7403  
Email Address ken@universalroof.com

Building Official: sq Date 6-12-14  
Verified Contractor's Licenses & Insurance are on file sq Date 6-11-14

Zoning Fee	\$	<u>30<sup>00</sup></u>
Permit Fee	\$	<u>85<sup>00</sup></u>
Review Fee	\$	<u>n/a</u>
3% Florida Surcharge	\$	<u>4<sup>00</sup></u>
Total Permit Fee	\$	<u>119<sup>00</sup></u>

NOTE: The Building Permit Number is required if the Roof Installation is associated with any construction or alteration where a Building Permit has been issued. Building Permit Number \_\_\_\_\_



Permit Number: \_\_\_\_\_  
Folio/Parcel Identification Number: 18-23-20-4386-03-880  
Prepared by: Joan Mellick

DOCH 20140285543 B: 10756 P: 6162  
06/10/2014 12:06:23 PM Page 1 of 1  
Rec Fee: \$10.00  
Martha O. Haynie, Comptroller  
Orange County, FL  
MB - Ret To: UNIVERSAL ROOF AND CONTRA

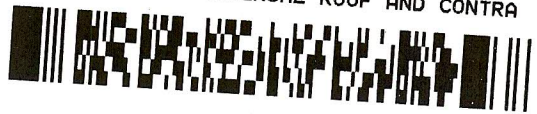

Return to: 5655 Cardew Rd.  
Orl. FL 32810

### NOTICE OF COMMENCEMENT

State of Florida, County of Orange  
The undersigned hereby gives notice that improvement will be made to certain real property, and in accordance with Chapter 713, Florida Statutes, the following information is provided in this Notice of Commencement.

- Description of property** (legal description of the property, and street address if available)  
LAKE CONWAY Estates SEC 7 2/38 LOT 388
- General description of improvement**  
RE-ROOF 41 sq. shingles
- Owner information or Lessee information if the Lessee contracted for the improvement**  
Name ANNE MORRIS  
Address 5012 GRAN LAC AVE. ORL. FL 32812  
Interest in Property Owner  
Name and address of fee simple titleholder (if different from Owner listed above)  
Name \_\_\_\_\_  
Address \_\_\_\_\_
- Contractor**  
Name Universal Roof & Contract Telephone Number 407-295-7403  
Address 5655 Cardew Rd. Orl. 32810
- Surety** (if applicable, a copy of the payment bond is attached)  
Name \_\_\_\_\_ Telephone Number \_\_\_\_\_  
Address \_\_\_\_\_ Amount of Bond \$ \_\_\_\_\_
- Lender**  
Name \_\_\_\_\_ Telephone Number \_\_\_\_\_  
Address \_\_\_\_\_
- Persons within the State of Florida designated by Owner upon whom notices or other documents may be served as provided by §713.13(1)(a)7, Florida Statutes.**  
Name \_\_\_\_\_ Telephone Number \_\_\_\_\_  
Address \_\_\_\_\_
- In addition to himself or herself, Owner designates the following to receive a copy of the Lienor's Notice as provided in §713.13(1)(b), Florida Statutes.**  
Name \_\_\_\_\_ Telephone Number \_\_\_\_\_  
Address \_\_\_\_\_
- Expiration date of notice of commencement** (the expiration date may not be before the completion of construction and final payment to the contractor, but will be 1 year from the date of recording unless a different date is specified)  
\_\_\_\_\_



By: [Signature] Deputy Comptroller  
Dated: \_\_\_\_\_  
I, MARtha O. HAYNIE, Comptroller of Orange County, Florida, do hereby certify that this is a true and correct copy of the documents reflected in the Official Records.

**WARNING TO OWNER: ANY PAYMENTS MADE BY THE OWNER AFTER THE EXPIRATION OF THE NOTICE OF COMMENCEMENT ARE CONSIDERED IMPROPER PAYMENTS UNDER CHAPTER 713, PART I, SECTION 713.13, FLORIDA STATUTES, AND CAN RESULT IN YOUR PAYING TWICE FOR IMPROVEMENTS TO YOUR PROPERTY. A NOTICE OF COMMENCEMENT MUST BE RECORDED AND POSTED ON THE JOB SITE BEFORE THE FIRST INSPECTION. IF YOU INTEND TO OBTAIN FINANCING, CONSULT WITH YOUR LENDER OR AN ATTORNEY BEFORE COMMENCING WORK OR RECORDING YOUR NOTICE OF COMMENCEMENT.**

Under penalty of perjury, I declare that I have read the foregoing notice of commencement and that the facts stated in it are true to the best of my knowledge and belief.

Anne Morris POA for Hedy Morris owner  
Signature of Owner or Lessee, or Owner's or Lessee's Authorized Officer/Director/Partner/Manager Signatory's Title/Office

The foregoing instrument was acknowledged before me this 5 day of 6/14 by Anne Morris  
as \_\_\_\_\_ for \_\_\_\_\_  
Type of authority, e.g., officer, trustee, attorney in fact Name of party on behalf of whom instrument was executed

[Signature] \_\_\_\_\_  
Signature of Notary Public - State of Florida Print, type, or stamp commissioned name of Notary Public

Personally Known OR Produced ID NEW YORK STATE  
Type of ID Produced ED 207-248-434

Comm# FF122333  
Expires 1/30/2017



## DURABLE POWER OF ATTORNEY (GENERAL)

KNOW ALL MEN BY THESE PRESENTS, that I, HEDY MORRIS, hereby make, constitute and appoint my husband, PETER J. MORRIS, and daughter, ANNE M. MORRIS, either one acting alone, or if neither of them is able and willing to act, then ROBERT D. MORRIS, my true and lawful attorney to act in, manage and conduct all my affairs, and for my use and benefit and as my act and deed, to do and execute and to concur with persons jointly interested with myself therein in the doing or executing of, all or any of the following acts and deeds:

This Durable Power of Attorney shall not be affected by my subsequent disability or incapacity; it being my desire that this authority be exercisable notwithstanding my subsequent disability or incapacity. This power of attorney is not contingent on my incapacity.

To buy, receive, lease, accept or otherwise acquire; to sell, convey, mortgage, pledge, quitclaim, or otherwise dispose of or encumber; to contract or agree for the acquisition, disposal or encumbrance of: any property whatsoever and wheresoever situated (be it real, personal, mixed, tangible or intangible) or any custody, possession, right or interest therein or pertaining thereto, upon such terms as my said attorney shall think proper.

FURTHER, to take hold, possess, invest, store, deposit, lease or let or otherwise manage any or all of my real, personal, mixed, tangible or intangible property which I now own or shall at any time hereafter acquire, including any interest therein or pertaining thereto; to eject, remove or relieve tenants or otherwise persons from, and recover possession of, the aforementioned property by all lawful means and maintain, protect, preserve, insure, remove, store, transport, repair, modify or improve such property or any part thereof.

FURTHER, to do and transact all and every kind of business of whatever kind or nature, including the receipt, collection, payment, compromise, settlement and adjustment of all accounts, legacies, bequests, interests dividends, annuities, claims, demands, promissory notes, debts, taxes and obligations which are now, or hereafter may be, due, owing, or payable by me or to me, including IRA's, pension and other tax-deferred plans.

FURTHER, to make, endorse, accept, receive, sign, execute, and deliver, deeds, assignments, agreements certificates, checks, notes, bonds, receipts, releases and other written instruments of whatever kind or nature, a may be necessary, convenient or proper in the exercise of the powers herein contained or as my said attorney may think fit or be advised; to make deposits or investments in, or withdrawals from, any account or holding which I may have, or may hereafter have, or be entitled to, in any bank, trust or investment institution, including credit unions, savings, and loan associations, and similar institutions; to access any safe deposit box therein; and to exercise any right or option or privilege pertaining thereto and to open or establish accounts, holdings or interest of whatever kind or nature with any such institution, in my name or in my said attorney's name or in both our name jointly, with or without right of survivorship; to access any safe deposit box in my name at any such institution

FURTHER, to buy, sell and trade in securities of any nature, of every kind and nature, and for such purpose to maintain and operate margin accounts with brokers, and to pledge any securities held or purchase by said attorney with such brokers as security for loans and advances made to said attorney.

FURTHER, to institute, prosecute, defend, compromise, arbitrate and dispose of, legal, or administrative actions, suits, attachments, or other such proceedings, or otherwise engage in litigation in connection with the exercise of the powers herein contained.

FURTHER, to borrow on my behalf any sum(s) of money on such terms and with such security as he or she may think fit, for that purpose to execute all promissory notes, bonds, mortgages and other implements which may be necessary or proper.





**POWER OF ATTORNEY**

I hereby name and appoint Joan Mellick

Of Universal Roofing to be my lawful attorney in fact

To act for me and apply to the City of Belle Isle

Building Department for a re roof permit for work to

Be performed at a location described as:

Section: 18 Township: 23 Range: 30 Lot: 4386 Block: 03-880

Subdivision: Lake Conway Estates

5012 Swan Lac - ave

(Address of job)

Hedy Morris

(Owner of property and address)

And to sign my name and do all things necessary to this appointment.

Ken Mellick

Ken Mellick  
(Signature of Certified Contractor)

The foregoing instrument was acknowledged before me this 6-10-14

By Ken Mellick

Who is personally know to me and who did not take an oath.

State of Florida  
County of Orange

Commission#: EE870187

Ashley Grow  
(Notary)

My Commission expires: 1/30/17 Stamp



ASHLEY GROW  
NOTARY PUBLIC  
STATE OF FLORIDA  
Comm# FF122033  
Expires 1/30/2017



FURTHER, to engage, employ and dismiss in my name, agents, counsel, and employees, and to appoint and remove at pleasure any substitute for, or agent under them in respect to any of the matters or things herein mentioned, or in which I may have an interest.

FURTHER, to act as my attorney or proxy in respect to any stocks, shares, bonds, investments, rights or interest I now have or may be in possession of hereafter; to engage and dismiss agents, counsel, and employees, to appoint and remove at pleasure any substitute for, or agent of, my said attorney in respect to all of the matters or things herein mentioned upon such terms as my attorney shall think fit.

FURTHER, to act as my attorney in fact or proxy in respect to any policy of insurance on my life or of any other type and in such capacity to exercise any rights, privileges or options which I may have thereunder or pertaining thereto, excluding however, the right to change beneficiaries and the right to make a cash surrender of the policy or policies, as distinguished from a surrender of the policy for loan conversion or other such purposes as may be provided therein.

FURTHER, to employ, contract with, or terminate physicians, nurses, other health care or housekeeping services personnel or agencies, nursing homes, hospitals, sanitariums, adult congregate living arrangements, etc., for my care; to sign instructions and consents on my behalf as requested or required by any physician, hospital, home care or housekeeping agency, sanitarium, etc., to have full and complete access to all my medical records, and to establish a qualified income trust if needed to qualify for Medicaid.

GIVING AND GRANTING unto my said attorney full power and authority to do and perform all and every act, deed, matter and thing whatsoever in and about my estate, property and affairs as fully and effectually to all intents and purposes as I might or could do in my own proper person if personally present, the above specially enumerated powers herein granted and not in limitation or definition thereof; and hereby ratifying all that my said attorney shall lawfully do or cause to be done by virtue of these presents.

IN WITNESS WHEREOF, I have hereunto set my hand and seal this 27<sup>th</sup> day of December, 2010, at Orlando, Orange County, Florida.

Peter J. Morris  
SIGNATURE OF WITNESS

Peter J. MORRIS  
Printed Name of Witness

Sally Lorenz  
SIGNATURE OF WITNESS

Sally Lorenz  
Printed Name of Witness

Hedy Morris  
HEDY MORRIS  
5012 Gran Lac Avenue  
Orlando, Florida 32812

STATE OF FLORIDA  
COUNTY OF ORANGE

I hereby certify that on this day, before me, an officer duly authorized in the State and County aforesaid to take acknowledgments, personally appeared HEDY MORRIS, who has produced a Florida Driver's License/ID as identification or is personally known to me, known to me to be the person who executed the aforesaid Power of Attorney and first being duly sworn acknowledged that she executed the foregoing instrument as a free and voluntary act and deed for the uses and purposes set forth therein.



Sally Lorenz  
NOTARY PUBLIC SIGNATURE





## City of Belle Isle

Universal Engineering Sciences 3532 Maggie Blvd., Orlando, FL 32811  
 Tel 407-581-8161 \* Fax 407-581-0313 \* [www.universalengineering.com](http://www.universalengineering.com)

### Product Approval Form

DATE: 10-10-14 PERMIT # \_\_\_\_\_

PROJECT ADDRESS 5012 OTAN LAC AVE, Belle Isle, FL  32809  32812

As required by Florida Statue 553.842 and Florida Administrative Code 9B-72m, please provide the information and approval numbers of the building components listed below if they will be utilized on the building or structure. FL Approved products are listed online at [www.floridabuilding.org](http://www.floridabuilding.org) or can be obtained from the local product supplier. The following information must be turned in with permit application and available onsite for inspections:

1. This Product Approval Cover Sheet
2. Internet screen from FloridaBuilding.org showing PA#, approval and code edition stamped
3. Manufacturer's installation details from FloridaBuilding.org and requirements for each product stamped

Product Type	Manufacturer	Model/Series	FL Product Approval #	Product Type	Manufacturer	Model/Series	FL Product Approval #
<b>EXTERIOR DOORS</b>				<b>WALL PANELS</b>			
Swinging				Sliding			
Sliding				Soffits			
Sectional/Rollup				Storefront			
Other				Glass Block			
				Other			
<b>WINDOWS</b>				<b>ROOFING PRODUCTS</b>			
Single/Dbf-Hung				Asphalt Shingles	<u>CertainTeed</u>	<u>Landmark</u>	<u>\$2444.00</u>
Horizontal Slider				Non Struct Metal			
Casement				Roofing Tiles			
Fixed				Single Ply Roof			
Mullion				Other			
Skylights							
Other							
<b>STRUCTURAL COMPONENTS</b>				<b>OTHER</b>			
Wood Connectors							
Wood Anchors							
Truss Plates							
Insulation Forms							
Lintels							
Other							

It is the applicant's responsibility to verify that specific products have been installed in accordance with their limitations and with the minimum required design pressures for the structure. Specific compliance will be verified during field inspections.

Applicant Signature *Ken [Signature]*

Date 10-10-14





**Product Approval**  
USER: Public User

[Product Approval Menu](#) > 
 [Product or Application Search](#) > 
 [Application List](#) > 
 **Application Detail**

FL #	FL5444-R4								
Application Type	Revision								
Code Version	2010								
Application Status	Approved								
Comments									
Archived									
Product Manufacturer	CertainTeed Corporation-Roofing								
Address/Phone/Email	PO Box 1100 1400 Union Meeting Rd Blue Bell, PA 19422 (215) 274-2350 Steven.T.Lawrey@saint-gobain.com								
Authorized Signature	Steven Lawrey Steven.T.Lawrey@saint-gobain.com								
Technical Representative	R. Allan Snyder								
Address/Phone/Email	PO Box 1100 1400 Union Meeting Road Blue Bell, PA 19422 Allan.R.Snyder@saint-gobain.com								
Quality Assurance Representative									
Address/Phone/Email									
Category	Roofing								
Subcategory	Asphalt Shingles								
Compliance Method	Evaluation Report from a Florida Registered Architect or a Licensed Florida Professional Engineer Evaluation Report - Hardcopy Received								
Florida Engineer or Architect Name who developed the Evaluation Report	Robert Nieminen								
Florida License	PE-59166								
Quality Assurance Entity	Underwriters Laboratories Inc.								
Quality Assurance Contract Expiration Date	06/09/2013								
Validated By	John W. Knezevich, PE Validation Checklist - Hardcopy Received								
Certificate of Independence	FL5444_R4_COI_Trinity_ERD_CI - Nieminen.pdf								
Referenced Standard and Year (of Standard)	<table border="0"> <thead> <tr> <th><u>Standard</u></th> <th><u>Year</u></th> </tr> </thead> <tbody> <tr> <td>ASTM D3161, Class F</td> <td>2006</td> </tr> <tr> <td>ASTM D3462</td> <td>2007</td> </tr> <tr> <td>ASTM D7158, Class H</td> <td>2007</td> </tr> </tbody> </table>	<u>Standard</u>	<u>Year</u>	ASTM D3161, Class F	2006	ASTM D3462	2007	ASTM D7158, Class H	2007
<u>Standard</u>	<u>Year</u>								
ASTM D3161, Class F	2006								
ASTM D3462	2007								
ASTM D7158, Class H	2007								
Equivalence of Product Standards Certified By									



Product Approval Method

Method 1 Option D

Date Submitted

12/14/2011

Date Validated

12/14/2011

Date Pending FBC Approval

12/21/2011

Date Approved

01/31/2012

**Summary of Products**

FL #	Model, Number or Name	Description
5444.1	CertainTeed Asphalt Roofing Shingles	3-tab, laminated, architectural and 4-tab asphalt roof shingles
<b>Limits of Use</b> Approved for use in HVHZ: No Approved for use outside HVHZ: Yes Impact Resistant: N/A Design Pressure: N/A Other: Refer to ER Section 5 for Limits of Use		<b>Installation Instructions</b> <a href="#">FL5444_R4_II_er120611FINAL_CERTAINTCEED_AspPh Shingle_FL5444-R4.pdf</a> Verified By: Robert Nieminen, PE PE-59166 Created by Independent Third Party: Yes <b>Evaluation Reports</b> <a href="#">FL5444_R4_AE_er120611FINAL_CERTAINTCEED_AspPh Shingle_FL5444-R4.pdf</a> Created by Independent Third Party: Yes

[Back](#)   [Next](#)

Contact Us :: [1940 North Monroe Street, Tallahassee FL 32399](#) Phone: 850-487-1824

The State of Florida is an AA/EEO employer. [Copyright 2007-2010 State of Florida.](#) :: [Privacy Statement](#) :: [Accessibility Statement](#) :: [Refu Statement](#)

Under Florida law, email addresses are public records. If you do not want your e-mail address released in response to a public-records request, send electronic mail to this entity. Instead, contact the office by phone or by traditional mail. If you have any questions, please contact 850.48 \*Pursuant to Section 455.275(1), Florida Statutes, effective October 1, 2012, licensees licensed under Chapter 455, F.S. must provide the Dep with an email address if they have one. The emails provided may be used for official communication with the licensee. However email address public record. If you do not wish to supply a personal address, please provide the Department with an email address which can be made avail the public. To determine if you are a licensee under Chapter 455, F.S., please click [here](#).

**Product Approval Accepts:**





TRINITY ERD

EXTERIOR RESEARCH & DESIGN, LLC.  
Certificate of Authorization #9503  
353 CHRISTIAN STREET, UNIT #13  
OXFORD, CT 06478  
PHONE: (203) 262-9245  
FAX: (203) 262-9243

## EVALUATION REPORT

CertainTeed Corporation  
1400 Union Meeting Road  
Blue Bell, PA 19422

Evaluation Report 3532.09.05-R4  
FL5444-R4  
Date of Issuance: 09/22/2005  
Revision 4: 12/06/2011

### SCOPE:

This Evaluation Report is issued under Rule 9N-3 and the applicable rules and regulations governing the use of construction materials in the State of Florida. The documentation submitted has been reviewed by Robert Nieminen, P.E. for use of the product under the Florida Building Code and Florida Building Code, Residential Volume. The products described herein have been designed to comply with the 2010 Florida Building Code.

### DESCRIPTION: CertainTeed Asphalt Roofing Shingles.

**LABELING:** Each unit shall bear labeling in accordance with the requirements of the Accredited Quality Assurance Agency noted herein.

**CONTINUED COMPLIANCE:** This Evaluation Report is valid until such time as the named product(s) changes, the referenced Quality Assurance documentation changes, or provisions of the Code that relate to the product change. Acceptance of this Evaluation Report by the named client constitutes agreement to notify Robert Nieminen, P.E. if the product changes or the referenced Quality Assurance documentation changes. Trinity|ERD requires a complete review of this Evaluation Report relative to updated Code requirements with each Code Cycle.

**ADVERTISEMENT:** The Evaluation Report number preceded by the words "Trinity|ERD Evaluated" may be displayed in advertising literature. If any portion of the Evaluation Report is displayed, then it shall be done in its entirety.

**INSPECTION:** Upon request, a copy of this entire Evaluation Report shall be provided to the user by the manufacturer or its distributors and shall be available for inspection at the job site at the request of the Building Official.

This Evaluation Report consists of pages 1 through 10.

### Prepared by:



**Robert J.M. Nieminen, P.E.**  
Florida Registration No. 59166, Florida DCA ANE1983

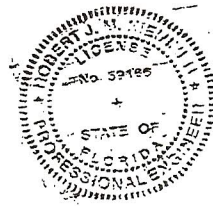

The facsimile seal appearing was authorized by Robert Nieminen, P.E. on 12/06/2011. This does not serve as an electronically signed document. Signed, sealed hardcopies have been transmitted to the Product Approval Administrator and to the named client.

### CERTIFICATION OF INDEPENDENCE:

1. Trinity|ERD does not have, nor does it intend to acquire or will it acquire, a financial interest in any company manufacturing or distributing products it evaluates.
2. Trinity|ERD is not owned, operated or controlled by any company manufacturing or distributing products it evaluates.
3. Robert Nieminen, P.E. does not have nor will acquire, a financial interest in any company manufacturing or distributing products for which the evaluation reports are being issued.
4. Robert Nieminen, P.E. does not have, nor will acquire, a financial interest in any other entity involved in the approval process of the product.



**6. INSTALLATION:**

- 6.1 Roof deck, slope, underlayment and fasteners shall comply with FBC 1507.2 / R905.2 and the shingle manufacturer's minimum requirements.
- 6.1.1 Underlayment shall be acceptable to CertainTeed Corporation and shall hold current Florida Statewide Product Approval, or be Locally Approved per Rule 9N-3, per FBC Sections 1507.2.3, 1507.2.4 or R905.2.3.
- 6.2 Installation of asphalt shingles shall comply with the manufacturer's current published instructions, using minimum four (4) nails per shingle in accordance with FBC 1507.2.7 or Section R905.2.6 and the minimum requirements herein.
- 6.2.1 Fasteners shall be in accordance with manufacturer's published requirements, but not less than FBC 1507.2.6 or R905.2.5. Staples are not permitted.
- 6.2.2 Where the roof slope exceeds 21 units vertical in 12 units horizontal, use the "Steep Slope" directions.
- 6.3 CertainTeed asphalt shingles are acceptable for use in reroof (tear-off) or recover applications, subject to the limitations set forth in FBC Section 1510 and CertainTeed published installation instructions.
- 6.3.1 **CT20™, XT™ 25, and XT™ 30:**

**LOW AND STANDARD SLOPE**  
**ENGLISH**

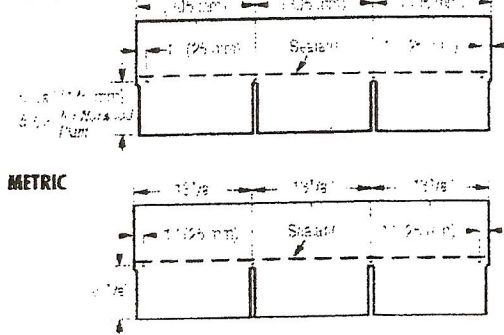

Figure 11-3: Use four nails for every full shingle.

**STEEP SLOPE**

Use four nails and six spots of asphalt roofing cement for every full shingle (Figure 11-4). Asphalt roofing cement meeting ASTM D 586 Type II is suggested.

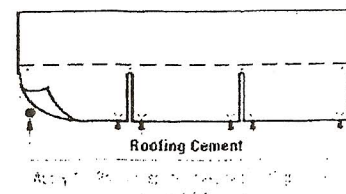

Figure 11-4: Use four nails and six spots of asphalt cement on steep slopes  
\*CAUTION: Excessive use of roofing cement can cause shingles to blister.

6.3.1.1 Hip & Ridge: Cut Shingles

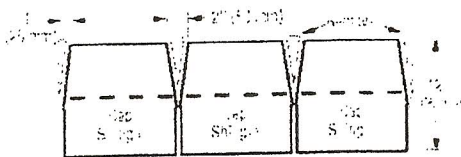

Figure 11-24: Cut tabs, then trim back to make cap shingles (English dimensions shown).

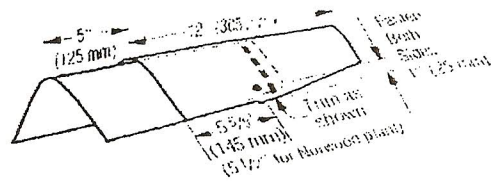

Figure 11-25: Installation of caps along the hips and ridges.

Note: For ASTM D3161 - Class F, use BASF Sonolastic NP 1 adhesive or Henkel PL® Polyurethane Roof & Flashing Sealant, in accordance with manufacturer's instructions.



**ROOFING SYSTEMS EVALUATION:**

**1. SCOPE:**

**Product Category:** Roofing  
**Sub-Category:** Asphalt Shingles  
**Compliance Statement:** CertainTeed Asphalt Roofing Shingles, as produced by CertainTeed Corporation, have demonstrated compliance with the following sections of the Florida Building Code and Florida Building Code, Residential Volume through testing in accordance with the following Standards. Compliance is subject to the Installation Requirements and Limitations / Conditions of Use set forth herein.

**2. STANDARDS:**

<u>Section</u>	<u>Property</u>	<u>Standard</u>	<u>Year</u>
1507.2.5, R905.2.4	Physical Properties	ASTM D3462	2007
1507.2.7.1, R905.2.6.1	Wind Resistance	ASTM D3161, Class F	2006
1507.2.7.1, R905.2.6.1	Wind Resistance	ASTM D7158, Class H	2007

**3. REFERENCES:**

<u>Entity</u>	<u>Examination</u>	<u>Reference</u>	<u>Date</u>
UL (TST 1740)	ASTM D3161	94NK9632	05/15/1998
UL (TST 1740)	ASTM D3161	99NK26506	11/23/1999
UL (TST 1740)	ASTM D3161	03CA12702	05/27/2003
UL (TST 1740)	ASTM D3161	03CA12702	06/16/2003
UL (TST 1740)	ASTM D3161	03NK29847	10/03/2003
UL (TST 1740)	ASTM D3161	04CA11329	05/24/2004
UL (TST 1740)	ASTM D3161	04CA32986	12/03/2004
UL (TST 1740)	ASTM D3161	05NK07049	04/15/2005
UL (TST 1740)	ASTM D3161	05NK16778	05/12/2005
UL (TST 1740)	ASTM D3161	05CA16778	05/12/2005
UL (TST 1740)	ASTM D3161	05NK14836	05/22/2005
UL (TST 1740)	ASTM D3161	05NK22800	06/22/2005
UL (TST 1740)	ASTM D3462	R684	09/21/2005
UL (TST 1740)	ASTM D7158	05NK08037	06/28/2006
UL (TST 1740)	ASTM D3161 & D3462	09CA28873	07/23/2009
UL (TST 1740)	ASTM D3462	10CA41303	10/07/2010
UL (TST 1740)	ASTM D3161	10CA41303	10/08/2010
UL (TST 1740)	ASTM D3161	10CA41303	10/27/2010
UL (TST 1740)	ASTM D7158	10CA44960	11/11/2010
UL (TST 1740)	ASTM D3161 & D3462	Service Confirmation	Exp. 06/09/2013
UL (QUA 1743)	Quality Control		

**4. PRODUCT DESCRIPTION:**

- 4.1 CT20™, XT™ 25 and XT™ 30 are fiberglass reinforced, 3-tab asphalt roof shingles.
- 4.2 Carriage House Shingle®, Centennial Slate™, Grand Manor Shingle®, Landmark™, Landmark™ Pro (formerly Landmark™ Plus), Landmark™ Premium, Landmark™ TL and Landmark™ Solaris are fiberglass reinforced, laminated asphalt roof shingles.
- 4.3 Presidential Shake™ and Presidential Shake TL™ are fiberglass reinforced, architectural asphalt roof shingles.
- 4.4 Hatteras™ and Highland Slate™ are fiberglass reinforced, 4-tab asphalt roof shingles.
- 4.5 Presidential Accessory, Accessory for Hatteras, Shangle Ridge™, Shadow Ridge™ and Cedar Crest™ are fiberglass reinforced accessory shingles for hip and ridge installation.
- 4.6 Any of the above listed shingles may be produced in AR (algae resistant) versions.

**5. LIMITATIONS:**

- 5.1 This Evaluation Report is not for use in the HVHZ
- 5.2 Fire Classification is not part of this Evaluation Report; refer to current Approved Roofing Materials Directory for fire ratings of this product.
- 5.3 Wind Classification:
  - 5.3.1 All shingles noted herein are Classified in accordance with FBC Tables 1507.2.7.1 and R905.2.6.1 to ASTM D3161, Class F and/or ASTM D7158, Class H, indicating the shingles are acceptable for us in all wind zones up to  $V_{asd} = 150$  mph ( $V_{ult} = 194$  mph). Refer to Section 6 for installation requirements to meet this wind rating.
  - 5.3.2 Presidential Accessory, Accessory for Hatteras, Shangle Ridge, Shadow Ridge and Cedar Crest hip & ridge shingles have been evaluated in accordance with ASTM D3161, Class F when BASF Sonolastic NP 1 adhesive or Henkel PL® Polyurethane Roof & Flashing Sealant, applied as specified in manufacturer's application instructions, indicating the shingles are acceptable for us in all wind zones up to  $V_{asd} = 150$  mph ( $V_{ult} = 194$  mph).
  - 5.3.3 Classification by ASTM D7158 applies to exposure category B or C and a building height of 60 feet or less. Calculations by a qualified design professional are required for conditions outside these limitations. Contact the shingle manufacturer for data specific to each shingle.
- 5.4 All products in the roof assembly shall have quality assurance audits in accordance with the Florida Building Code and F.A.C. Rule 9N-3.



6.3.2 **Carriage House Shingle®, Centennial Slate™ and Grand Manor Shingle®:**

**LOW AND STANDARD SLOPE**

Use five nails for every full Shingle.

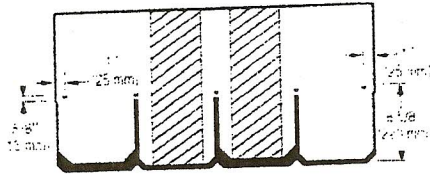

Figure 17-4: Use five nails for every full Grand Manor Shingle, Carriage House Shingle, or Centennial Slate

**STEEP SLOPE**

Use seven nails and three spots of asphalt roofing cement for every full Grand Manor Shingle. Use five nails and three spots of asphalt roofing cement for every full Carriage House Shingle and Centennial Slate. Apply asphalt roofing cement 1" (25 mm) from edge of shingle (Figure 17-5). Asphalt roofing cement meeting ASTM D1586 Type II is suggested.

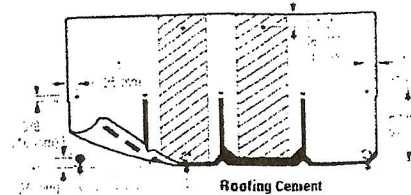

Figure 17-5: When installing Grand Manor Shingles on steep slopes use seven nails and three spots of asphalt roofing cement

6.3.2.1 **Hip & Ridge: Shingle® Ridge**

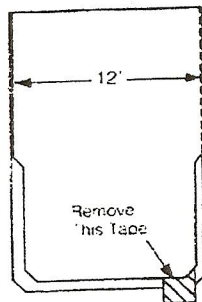

Figure 17-18: Shingle® Ridge.

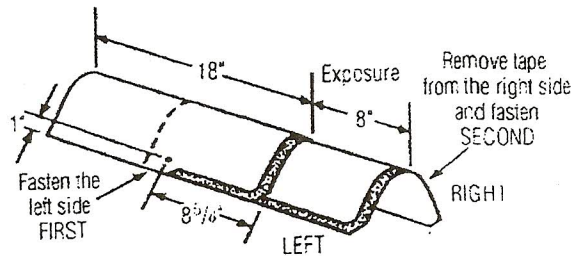

Figure 17-19: Installation of Shingle® Ridge shingles on hips and ridges.

Note: For ASTM D3161 - Class F, use BASF Sonolastic NP 1 adhesive or Henkel PL® Polyurethane Roof & Flashing Sealant in accordance with manufacturer's instructions.

6.3.3 **Landmark™, Landmark™ Pro (formerly Landmark™ Plus), Landmark™ Premium, Landmark™ TL and Landmark™ Solaris:**

**LOW AND STANDARD SLOPE**

**METRIC DIMENSIONS**

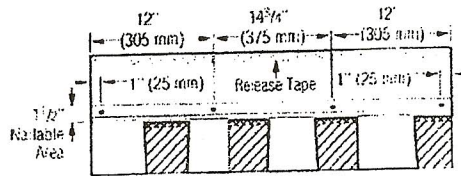

**LANDMARK TL**

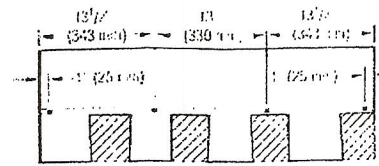
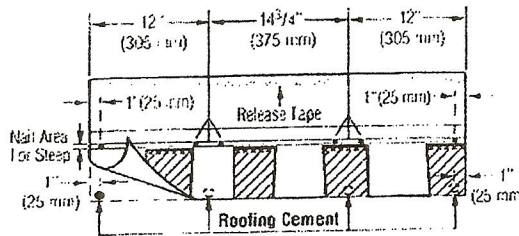

Figure 13-4 Use four nails for every full shingle

**STEEP SLOPE**

Use six nails and four spots of asphalt roofing cement for every full laminated shingle. See below. Asphalt roofing cement should meet ASTM D4586 Type II. Apply 1" spots of asphalt roofing cement under each corner and at about 12" to 13" in from each edge

**METRIC DIMENSIONS**



**LANDMARK TL**

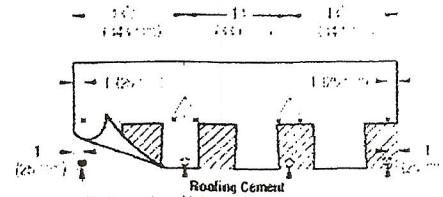

Figure 13-5 Use six nails and four spots of asphalt roofing cement on steep slopes

6.3.3.1 **Hip & Ridge, Option 1: Shadow Ridge™**

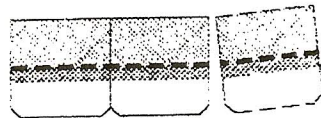
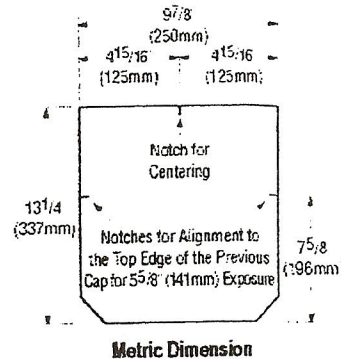
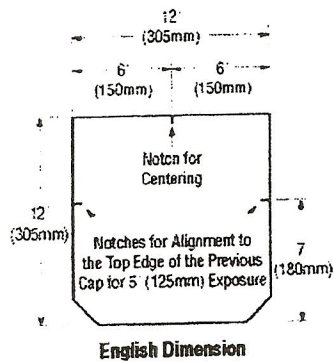

Figure 13-16: Shadow Ridge accessory shingles detach easily from three-piece units to make 72 individual cap pieces.





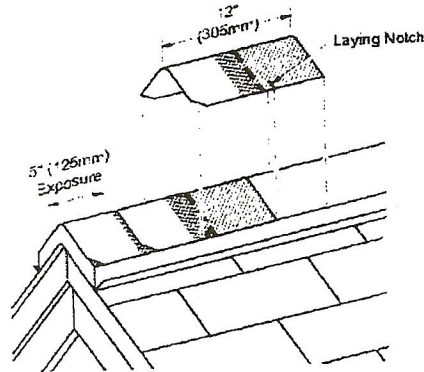
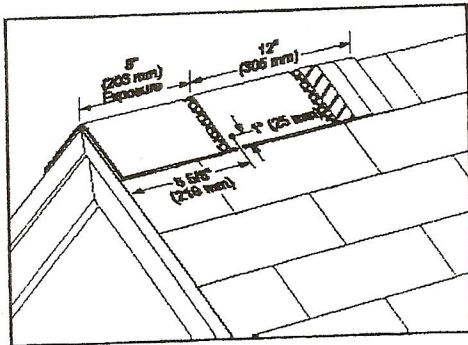

Figure 13-20: Use laying notches to center shingles on hips and ridges, and to locate the correct exposure.

Note: For ASTM D3161 - Class F, use BASF Sonolastic NP 1 adhesive or Henkel PL® Polyurethane Roof & Flashing Sealant in accordance with manufacturer's instructions.

6.3.3.2 Hip & Ridge, Option 2: Cedar Crest™

Use two fasteners per shingle. For the starter shingle, place fastener 1-inch from each side edge and about 2-inch up from the starter shingle's exposed butt edge. For each full Cedar Crest shingle, please fasteners 8-5/8-inch up from its exposed butt edge and 1-inch from each side edge.



Note: For ASTM D3161 - Class F, use BASF Sonolastic NP 1 adhesive or Henkel PL® Polyurethane Roof & Flashing Sealant to hand-seal Cedar Crest shingles. Apply NP 1 or PL adhesive from the middle of the shingle's raised overlay on the top piece and extending approximately 4-inch along the sides of the headlap along a line 3/4 to 1-inch from each side of the shingle's headlap. Immediately align and apply the overlying shingle, gently pressing tab sides into the adhesive, and install nails. To secure the other side, apply a 1-inch diameter spot of NP 1 or PL adhesive between the shingle layers.

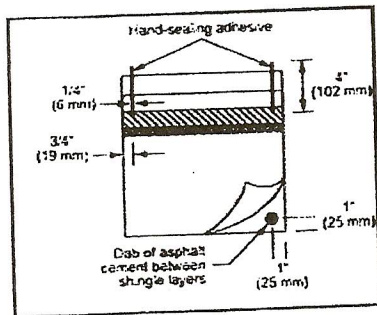

6.3.4 **Presidential Shake™ and Presidential Shake TL™:**

**LOW AND STANDARD SLOPE:**

For low and standard slopes, use five nails for each full Presidential shingle as shown below.

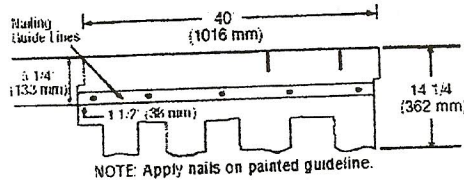

Figure 16-6: Fastening Presidential and Presidential TL Shake shingles on low and standard slopes.

**STEEP SLOPE:**

For steep slopes, use nine nails for each full Presidential shingle and apply 1" diameter spots of asphalt roofing cement under each shingle tab. After applying 5 nails in between the masting guide lines, apply 4 nails 1" above tab cutouts making certain tabs of overlapping shingle cover nails.

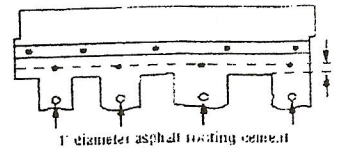

Figure 16-7: Fastening Presidential and Presidential TL Shake shingles on steep slopes.

6.3.4.1 Hip & Ridge, Option 1: Presidential Accessory

**PRESIDENTIAL ACCESSORY**

Presidential accessory shingles can be used for covering hips and ridges. Apply shingles up to the ridge (expose no more than 7" from the bottom edge of the "tooth.") Fasten each accessory with two fasteners. The fasteners must be 1 3/4" long or longer, so they penetrate either 3/4" into the deck or completely through the deck. Presidential accessory comes in two different sizes: Accessory produced in Birmingham, AL is 12" x 12"; Portland, OR produces 9 7/8" x 13 1/4" accessory.

Note: For ASTM D3161 - Class F, use BASF Sonolastic NP 1 adhesive or Henkel PL® Polyurethane Roof & Flashing Sealant in accordance with manufacturer's instructions.

6.3.4.2 Hip & Ridge, Option 2: Refer to instructions herein for Cedar Crest™ hip and ridge shingles.

6.3.5 **Hatteras™:**

**LOW, STANDARD AND STEEP SLOPE:**

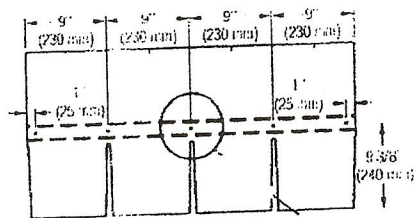

Figure 15-3: Fastening Hatteras Shingles on low and standard slopes.

For low and standard slopes, use five nails for each full Hatteras shingle as shown above.

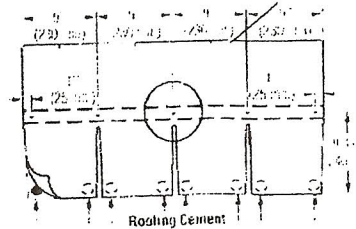

Figure 15-4: Fastening Hatteras Shingles on steep slopes.

For steep slopes, use five nails and eight spots of asphalt roofing cement for each full Hatteras shingle as shown above. Apply 1 (25mm) diameter spots of roofing cement (AS:MD 1580 type I suggested) under each tab corner. Press shingle into place; do not expose cement.  
CAUTION: Too much roofing cement can cause shingles to blister.



6.3.5.1 Hip & Ridge, Option 1: Accessory for Hatteras

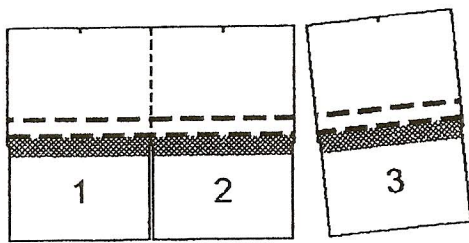
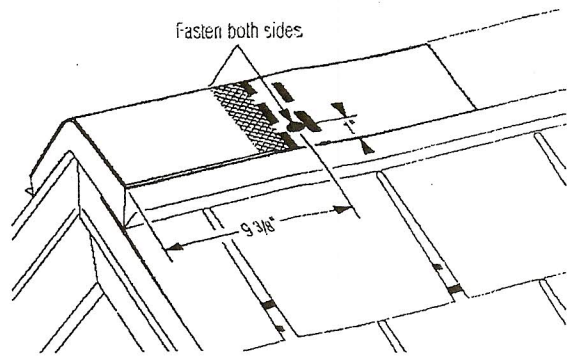

Figure 15-14: 18 three-piece units separate to make 54 Hatteras Accessory shingles.



Note: For ASTM D3161 - Class F, use BASF Sonolastic NP 1 adhesive or Henkel PL® Polyurethane Roof & Flashing Sealant in accordance with manufacturer's instructions.

6.3.5.2 Hip & Ridge, Option 2: Cut Hatteras Shingles

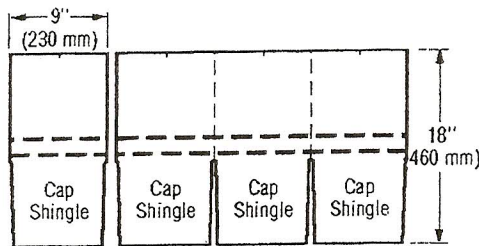

Figure 15-20: Cut Hatteras shingles to make cover cap.

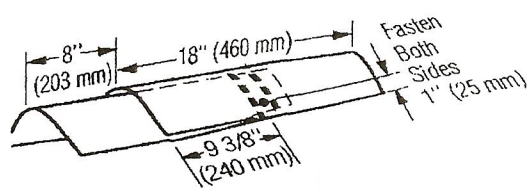

Figure 15-21: Installation of caps along hips and ridges.

Note: For ASTM D3161 - Class F, use BASF Sonolastic NP 1 adhesive or Henkel PL® Polyurethane Roof & Flashing Sealant in accordance with manufacturer's instructions.

Exterior Research and Design, LLC.  
Certificate of Authorization #9503

Evaluation Report 3532.09.05-R4  
FL5444-R4  
Revision 4: 12/06/2011  
Page 9 of 10

10. QUALITY ASSURANCE ENTITY:

Underwriters Laboratories – QUA1743; (414) 248-6409; karen.buchmann@us.ul.com

- END OF EVALUATION REPORT -

Exterior Research and Design, LLC.  
Certificate of Authorization #9503

Evaluation Report 3532.09.05-R4  
FL5444-R4  
Revision 4: 12/06/2011  
Page 10 of 10